

ARMY TM 9-2320-366-20-3
AIR FORCE T.O. 36A12-1C-1102-3

TECHNICAL MANUAL
MAINTENANCE INSTRUCTIONS
UNIT MAINTENANCE
M1083 SERIES, 5-TON, 6 X 6,
MEDIUM TACTICAL VEHICLES (MTV)
VOLUME NO. 3 OF 5

MODEL	NSN	EIC	HOW TO USE THIS MANUAL PAGE v
TRK, CAR., MTV, M1083 W/WN W/O WN	2320-01-360-1895 2320-01-354-3386	BT3 BR2	CENTRAL TIRE INFLATION (CTIS) SYSTEM TROUBLESHOOTING PAGE 2-2007
TRK, CAR., MTV, W/MATL HDLG EQPT (MHE), M1084	2320-01-354-3387	BR3	STEERING HYDRAULIC SYSTEM TROUBLESHOOTING PAGE 2-2213
TRK, CAR., MTV, LWB, M1085 W/WN W/O WN	2320-01-360-1897 2320-01-354-4530	BT5 BR7	A I R T R A N S P O R T TROUBLESHOOTING PAGE 2-2219
TRK, CAR., MTV, LWB, W/MATL HDLG EQPT (MHE), M1086	2320-01-354-4531	BR8	CAB TILT AND SPARE TIRE RETAINER TROUBLESHOOTING PAGE 2-2413
TRK, TRACTOR, MTV, M1088 W/WN W/O WN	2320-01-360-1892 2320-01-355-4332	BTY BTJ	FRAME TROUBLESHOOTING PAGE 2-2435
TRK, WKR, MTV, M1089	2320-01-354-4528	BR4	ENGINE MAINTENANCE PAGE 3-1
TRK, DUMP, MTV, M1090 W/WN W/O WN	2320-01-360-1893 2320-01-354-4529	BTZ BR5	FUEL SYSTEM MAINTENANCE PAGE 4-1
TRK, CHAS, MTV, M1092	2320-01-354-3382	BRZ	EXHAUST SYSTEM MAINTENANCE PAGE 5-1
TRK, CAR., MTV, AIR DROP, M1093 W/WN W/O WN	2320-01-360-1896 2320-01-355-3063	BT4 BR9	COOLING SYSTEM MAINTENANCE PAGE 6-1
TRK, DUMP, MTV, AIR DROP, M1094 W/WN W/O WN	2320-01-360-1984 2320-01-355-3062	BT2 BTK	ELECTRICAL SYSTEM MAINTENANCE PAGE 7-1
TRK, CHAS, MTV, LWB, M1096	2320-01-354-4527	BR6	

DISTRIBUTION STATEMENT A. Approved for public release; distribution is unlimited.

HEADQUARTERS, DEPARTMENTS OF THE ARMY AND THE AIR FORCE

SEPTEMBER 1998

HEADQUARTERS
DEPARTMENTS OF THE ARMY
AND THE AIR FORCE

Washington, D.C., 1 July 2003

CHANGE
NO. 1

TECHNICAL MANUAL
MAINTENANCE INSTRUCTIONS
UNIT MAINTENANCE
M1083 SERIES, 5-TON, 6x6,
MEDIUM TACTICAL VEHICLE
(MTV)

VOLUME NO. 3 OF 5

TM 9-2320-366-20-3, 15 September 1998, is changed as follows:

1. Remove old pages and insert new pages as indicated below.
2. New or changed material is indicated by a vertical bar in the out margin of the page.
3. Added or revised illustrations are indicated by a vertical bar adjacent to the illustration.

Remove Pages	Insert Pages	Remove Pages	Insert Pages
m and n	m and n	2-2417/(2-2418 Blank) thru	2-2417/(2-2418 Blank) thru
none	A thru D	2-2426	2-2426
i thru v/(vi Blank)	i thru vi	none	2-2426.1 and 2-2426.2
none	2-2006.1/(2-2006.2 Blank)	2-2427 and 2-2428	2-2427 and 2-2428
2-2007 thru 2-2010	2-2007 thru 2-2010	none	2-2428.1 thru 2-2428.8
2-2069 thru 2-2080	2-2069 thru 2-2079/(2-2080 Blank)	2-2429 and 2-2430	2-2429 and 2-2430
2-2081 thru 2-2100	none	none	2-2430.1 thru 2-2430.8
2-2101 thru 2-2104	(2-2101 Blank)/2-2102 thru 2-2104	2-2431 and 2-2432	2-2431 and 2-2432
2-2109 thru 2-2122	2-2109 thru 2-2122	none	2-2432.1 and 2-2432.2
2-2143 thru	2-2143 thru	2-2433/(2-2434 Blank)	2-2433/(2-2434 Blank)
2-2149/(2-2150 Blank)	2-2149/(2-2150 Blank)	none	2-2446.1/(2-2446.2 Blank)
2-2219 thru 2-2228	2-2219 thru 2-2228	2-2447 and 2-2448	2-2447 and 2-2448
none	2-2228.1 thru 2-2228.18	3-1 and 3-2	3-1 and 3-2
2-2229 and 2-2230	2-2229 and 2-2230	3-15 thru 3-21/(3-22 Blank)	3-15 thru 3-21/(3-22 Blank)
none	2-2230.1 thru 2-2230.14	4-1 and 4-2	4-1 and 4-2
2-2231 thru 2-2234	2-2231 thru 2-2234	4-5 and 4-6	4-5 and 4-6
none	2-2234.1 thru 2-2234.22	4-9 and 4-10	4-9 and 4-10
2-2235/(2-2236 Blank) thru	2-2235/(2-2236 Blank) thru	none	4-10.1 and 4-10.2
2-2238	2-2237/(2-2238 Blank)	4-11 thru 4-18	4-11 thru 4-18
2-2239 thru 2-2241/(2-2242 Blank)	none	4-41 thru 4-48	4-41 thru 4-48
2-2253 and 2-2254	2-2253 and 2-2254	4-59 and 4-60	4-59 and 4-60
none	2-2254.1 and 2-2254.2	4-63 and 4-64	4-63 and 4-64
2-2255 and 2-2256	2-2255 and 2-2256	4-69 and 4-70	4-69 and 4-70
2-2263 and 2-2264	2-2263 and 2-2264	4-81 thru 4-84	4-81 thru 4-84
none	2-2264.1 and 2-2264.2	5-1 and 5-2	5-1 and 5-2
2-2265 and 2-2266	2-2265 and 2-2266	5-7 thru 5-15/(5-16 Blank)	5-7 thru 5-15/(5-16 Blank)
2-2271 and 2-2272	2-2271/(2-2272 Blank)	6-1 thru 6-4	6-1 thru 6-4
2-2273 thru 2-2370	none	none	6-4.1 and 6-4.2
2-2371 and 2-2372	(2-2371 Blank)/2-2372	6-5 thru 6-24	6-5 thru 6-24
2-2413 and 2-2414	2-2413 and 2-2414	none	6-24.1/(6-24.2 Blank)
none	2-2414.1/(2-2414.2 Blank) thru 2-2414.12	6-25 thru 6-28	6-25 thru 6-28
2-2415 and 2-2416	2-2415 and 2-2416	6-33 and 6-34	6-33 and 6-34
none	2-2416.1/(2-2416.2Blank) thru 2-2416.10	6-39 and 6-40	6-39 and 6-40

Place this change sheet in the front of the publication for reference purposes.

Remove Pages	Insert Pages	Remove Pages	Insert Pages
6-49 and 6-50	6-49 and 6-50	None	D-7/(D-8 Blank)
6-53 and 6-54	6-53 and 6-54	E-1 thru E-6	E-1 thru E-6
6-67 thru 6-72	6-67 thru 6-72	E-15 and E-16	E-15 and E-16
none	6-72.1/(6-72.2 Blank)	none	E-27 thru E-31/(E-32 Blank)
6-73 thru 6-78	6-73 thru 6-78	G-1 thru G-11/(G-12 Blank)	G-1 thru G-12
7-1 thru 7-6	7-1 thru 7-6	H-1 thru H-12	H-1 thru H-12
7-9 thru 7-12	7-9 thru 7-12	H-21 and H-22	H-21 and H-22
7-27 thru 7-34	7-27 thru 7-34	H-25 thru H-28	H-25 thru H-28
7-37 and 7-38	7-37 and 7-38	H-31 and H-32	H-31 and H-32
none	7-38.1 thru 7-38.4	none	K-1 thru K-4
7-43 and 7-44	7-43 and 7-44	INDEX-1 thru INDEX-14	INDEX-1 thru INDEX-13/ (INDEX-14 Blank)
7-47 and 7-48	7-47 and 7-48	FO-1 FP-1/(FP-2 Blank)	FO-1 FP-1/(FP-2 Blank)
7-55 and 7-56	7-55 and 7-56	thru FP-21/(FP-22 Blank)	thru FP-21/(FP-22 Blank)
7-59 and 7-60	7-59 and 7-60	FO-1 FP-25/(FP-26 Blank)	FO-1 FP-25/(FP-26 Blank)
7-67 and 7-68	7-67 and 7-68	FO-1 FP-29/(FP-30 Blank)	FO-1 FP-29/(FP-30 Blank)
7-73 and 7-74	7-73 and 7-74	thru FP-67/(FP-68 Blank)	thru FP-67/(FP-68 Blank)
7-79 and 7-80	7-79 and 7-80	FO-1 FP-75/(FP-76 Blank)	FO-1 FP-75/(FP-76 Blank)
7-83 and 7-84	7-83 and 7-84	thru FP-79/(FP-80 Blank)	thru FP-79/(FP-80 Blank)
7-91 thru 7-94	7-91 thru 7-94	DA FORM 2028-2 Sample	DA FORM 2028-2 Sample
7-109 and 7-110	7-109 and 7-110	DA FORM 2028-2	DA FORM 2028-2
7-123 and 7-124	7-123 and 7-124	DA FORM 2028-2	DA FORM 2028-2
7-137 and 7-138	7-137 and 7-138	DA FORM 2028-2	DA FORM 2028-2
7-145 and 7-146	7-145 and 7-146	DA FORM 2028-2	DA FORM 2028-2
none	7-146.1/(7-146.2 Blank)	Metric Conversion Chart	Metric Conversion Chart
none	7-150.1/(7-150.2 Blank)	Cover	Cover
7-151 and 7-152	7-151 and 7-152		
7-159 and 7-160	7-159 and 7-160		
none	7-166.1/(7-166.2 Blank)		
7-167 and 7-168	7-167 and 7-168		
7-171 and 7-172	7-171 and 7-172		
none	7-172.1/(7-172.2 Blank)		
7-189 thru 7-200	7-189 thru 7-200		
none	7-200.1/(7-200.2 Blank)		
7-201 and 7-202	7-201 and 7-202		
7-207 thru 7-216	7-207 thru 7-216		
7-219 thru 7-230	7-219 thru 7-230		
7-241 and 7-242	7-241 and 7-242		
none	7-242.1/(7-242.2 Blank)		
7-243 thru 7-248	7-243 thru 7-248		
7-253 thru 7-256	7-253 thru 7-256		
7-275 and 7-276	7-275 and 7-276		
7-279 thru 7-286	7-279 thru 7-286		
none	7-286.1 and 7-286.2		
7-287 thru 7-290	7-287 thru 7-290		
7-295 thru 7-300	7-295 thru 7-300		
7-305 thru 7-316	7-305 thru 7-316		
7-319 thru 7-324	7-319 thru 7-324		
7-335 thru 7-338	7-335 thru 7-338		
7-345 and 7-346	7-345 and 7-346		
7-351 thru 7-356	7-351 thru 7-356		
A-1 thru A-4	A-1 thru A-4		
B-3 and B-4	B-3 and B-4		
B-23 thru B-30	B-23 thru B-29/(B-30 Blank)		
C-1 thru C-4	C-1 thru C-4		
D-1 thru D-5/(D-6 Blank)	D-1 thru D-6		

Place this change sheet in the front of the publication for reference purposes.

By Order of the Secretary of the Army:

Official:



JOEL B. HUDSON

*Administrative Assistant to the
Secretary of the Army*

0110111

JOHN M. KEANE
*General, United States Army
Acting Chief of Staff*

DISTRIBUTION: To be distributed in accordance with the initial distribution number
(IDN) 380940, requirements for TM 9-2320-366-20-3

WARNING SUMMARY

WARNING

EXHAUST GASES CAN KILL

1. **DO NOT** operate your vehicle engine in an enclosed area.
2. **DO NOT** idle vehicle engine with cab windows closed.
3. **DO NOT** drive vehicle with inspection plates or covers removed.
4. **BE ALERT** at all times for exhaust odors.
5. **BE ALERT** for exhaust poisoning symptoms, they are:
 - Headache
 - Dizziness
 - Sleepiness
 - Loss of Muscular Control
6. **IF YOU SEE** another person with exhaust poisoning symptoms:
 - Remove person from area.
 - Expose to open air.
 - Keep person warm.
 - Do not permit person to move.
 - Administer cardiopulmonary resuscitation, if necessary.*

* For cardiopulmonary resuscitation, refer to FM 21-11.

WARNING

Remove rings, bracelets, watches, necklaces, and any other jewelry before working around vehicle. Jewelry can catch on equipment and cause injury or short across electrical circuit and cause severe burns or electrical shock. Batteries can explode from a spark. Battery acid is harmful to skin and eyes. Always wear eye protection and rubber gloves when working with batteries. Failure to comply may result in injury to personnel.

WARNING

Do not work on fuel system when engine is hot; fuel can be ignited by a hot engine.

WARNING SUMMARY (CONT)

WARNING

Battery acid (electrolyte) is extremely harmful. Always wear safety goggles and rubber gloves, and do not smoke when performing maintenance on batteries. Injury will result if acid contacts skin or eyes. Wear rubber apron to prevent clothing being damaged. Failure to comply may result in injury to personnel.

WARNING

Adhesives, solvents, and sealing compounds can burn easily, can give off harmful vapors, and are harmful to skin and clothing. Keep away from open fire and use in a well-ventilated area. If adhesive, solvent, or sealing compound gets on skin or clothing, wash immediately with soap and water. Failure to comply may result in injury to personnel.

WARNING

Dry Cleaning Solvent (P-D-680) is TOXIC and flammable. Wear protective goggles and gloves; use only in well ventilated area; avoid contact with skin, eyes, and clothes, and do not breathe vapors. Keep away from heat or flame. Never smoke when using solvent; the flashpoint for Type I Dry Cleaning Solvent is 100°F (38°C) and for Type II is 130°F (50°C). Failure to comply may result in serious injury or death to personnel.

If personnel become dizzy while using Dry Cleaning Solvent, immediately get fresh air and medical help. If Dry Cleaning Solvent contacts skin or clothes, flush with cold water. If Dry Cleaning Solvent contacts eyes, immediately flush eyes with water and get immediate medical attention. Failure to comply may result in injury to personnel.

WARNING

Diesel fuel is flammable. If fuel is spilled, clean it up immediately. Failure to comply may result in serious injury or death to personnel.

WARNING

Diesel fuel is flammable. Do not fill fuel tank with engine running, while smoking, or when near an open flame. Never overfill the tank or spill fuel. If fuel is spilled, clean it up immediately. Failure to comply may result in serious injury or death to personnel.

WARNING

Use care when removing/installing springs. Springs are under tension and can act as projectiles when being removed. Failure to comply can cause injury to personnel.

WARNING

Adhesive sealant MIL-S-46163 can damage your eyes. Wear safety goggles/glasses when using; avoid contact with eyes. If sealant contacts eyes, flush eyes with water and get immediate medical attention. Failure to comply may result in injury to personnel.

WARNING

After Nuclear, Biological, or Chemical (NBC) exposure of vehicle, all air filters shall be handled with extreme caution. Unprotected personnel may experience serious injury or death if residual toxic agents or radioactive material are present. If vehicle is exposed to chemical or biological agents, servicing personnel shall wear protective mask, hood, protective overgarments, and chemical protective gloves and boots in accordance with FM-3-4. All contaminated air filters shall be placed in double-lined plastic bags and moved swiftly to a segregation area away from the worksite. The same procedure applies for radioactive dust contamination. The Company NBC team should measure radiation prior to filter removal to determine extent of safety procedures required per the NBC Annex to the unit Standard Operating Procedures (SOP). The segregation area in which the contaminated air filters are temporarily stored shall be marked with appropriate NBC placards. Final disposal of contaminated air filters shall be in accordance with local SOP. Decontamination operation shall be in accordance with FM-3-5 and local SOP. Failure to comply may result in serious injury or death to personnel.

WARNING

Ensure exhaust system is cool before performing maintenance. Failure to comply may result in injury to personnel.

WARNING

Wear appropriate eye protection when working under vehicle due to the possibility of falling debris. Failure to comply may result in injury to personnel.

WARNING

Post signs that read "NO SMOKING WITHIN 50 FEET" when working with open fuel, fuel lines or fuel tanks. Failure to comply may result in injury to personnel or damage to equipment.

WARNING

Do not operate vehicle with muffler removed. Toxic exhaust fumes may enter cab, resulting in serious injury or death to personnel.

WARNING SUMMARY (CONT)

WARNING

Exhaust pipe, transmission oil lines, and transmission scavenge pump hose may be hot to the touch. Extreme care should be taken when checking exhaust pipe, transmission oil lines, and transmission scavenge pump hose for leaks. Failure to comply may result in injury to personnel.

WARNING

Compressed air used for cleaning purposes will not exceed 30 psi (207 kPa). Use only with effective chip guarding and personal protective equipment (goggles/shield, gloves, etc). Failure to comply may result in injury to personnel.

WARNING

Wheel drum weighs approximately 90 lbs (41 kgs). Use the aid of an assistant to help remove wheel drum. Failure to comply may result in injury to personnel.

WARNING

Wheel drum weighs approximately 90 lbs (41 kgs). Use the aid of an assistant to help install wheel drum. Failure to comply may result in injury to personnel.

WARNING

Brake shoes may be covered with dust. Breathing this dust may be harmful to your health. Do not use compressed air to clean brake shoes. Wear a filter mask approved for use against brake dust. Failure to comply may result in injury to personnel.

WARNING

Cage spring brake before air chamber is removed or severe injury to personnel will occur.

WARNING

Ensure air chamber is caged prior to installation. Failure to comply may result in injury to personnel.

WARNING

Ensure that tire is totally deflated before removing self-locking nuts. Failure to comply may result in serious injury or death to personnel.

WARNING

Spring brakes must be caged before attempting replacement of a rear axle wheel stud. Failure to comply may result in severe injury to personnel.

WARNING

Wear protective goggles to protect against possible injury from release of high pressure air. Failure to comply may result in injury to personnel.

WARNING

Prolonged contact with lubricating oil (MIL-L-2104) may cause a skin rash. Skin and clothing that come in contact with lubricating oil should be thoroughly washed immediately. Saturated clothing should be removed immediately. Areas in which lubricating oil is used should be well ventilated to keep fumes to a minimum. Failure to comply may result in injury to personnel.

WARNING

Hydraulic fluid (MIL-H-5606) is TOXIC. Wear protective goggles and gloves; use only in well ventilated area; avoid contact with skin, eyes, and clothes. Skin and clothing that come in contact with hydraulic oil should be washed immediately. Saturated clothing should be removed immediately. Failure to comply may result in injury to personnel.

WARNING

Never let moving wire rope slide through hands, even when wearing gloves. A broken wire could cut through gloves and cut hands. Failure to comply may result in injury to personnel.

WARNING

Wear appropriate eye protection when removing rivets. Failure to comply may result in injury to personnel.

WARNING

Wear appropriate eye protection when drilling holes. Failure to comply may result in injury to personnel.

WARNING

Wear leather gloves at all times when handling winch cable. Do not allow cable to slide through hands even with gloves on. Broken wires may cause injury.

WARNING SUMMARY (CONT)

WARNING

Use extreme caution when working around moving cable. Failure to do so may result in serious injury to personnel.

WARNING

Caution must be exercised while cab is raised. Ensure that locking mechanism is functioning properly before proceeding. Failure to comply may result in death or serious injury to personnel and damage to equipment.

WARNING

Diesel fuel is flammable. Arctic heater components and fuel lines may contain small amounts of fuel. If fuel is spilled, clean up immediately. Failure to comply may result in serious injury or death to personnel.

WARNING

Coolant may be very hot and under pressure from engine operation. Ensure engine is cool before performing maintenance. Failure to comply may result in injury to personnel.

WARNING

Light Material Handling Crane (LMHC) weighs approximately 250 lbs (114 kgs). Attach a suitable lifting device prior to removal. Failure to comply may result in injury to personnel.

WARNING

Light Material Handling Crane (LMHC) mast weighs approximately 110 lbs (50 kgs). Attach a suitable lifting device prior to installation. Failure to comply may result in injury to personnel or damage to equipment.

WARNING

Light Material Handling Crane (LMHC) boom assembly weighs approximately 150 lbs (68 kgs). Use an assistant when removing boom assembly. Failure to comply may result in injury to personnel.

WARNING

Light Material Handling Crane (LMHC) boom weighs approximately 60 lbs (27 kgs). Attach a suitable lifting device prior to installation. Failure to comply may result in injury to personnel or damage to equipment.

WARNING

Machine gun ring assembly weighs approximately 350 pounds (159 kgs). Attach a suitable lifting device prior to removal. Failure to comply may result in injury to personnel or damage to equipment.

WARNING

Ensure vehicle is on level ground prior to installation/removal of collapsible drums. Failure to comply may result in serious injury or death to personnel or damage to equipment.

WARNING

Ensure cargo bed is free of equipment and debris and not warped or damaged in any way. Failure to comply may result in serious injury or death to personnel or damage to equipment.

WARNING

Both collapsible drums weigh approximately 235 lbs (107 kgs) empty and 3800 lbs (1725 kgs) full. Attach a suitable lifting device prior to installation. Failure to comply may result in serious injury or death to personnel or damage to equipment.

WARNING

S-280 shelter weighs approximately 1500 lbs (680 kgs) empty. Attach a suitable lifting device prior to installation. Failure to comply may result in serious injury or death to personnel or damage to equipment.

WARNING

Ensure vehicle is on level ground prior to installation or removal of tank and pump unit. Failure to comply may result in serious injury or death to personnel or damage to equipment.

WARNING

Tank weighs approximately 500 lbs (227 kgs) empty or 4000 lbs (1816 kgs) full. Attach a suitable lifting device prior to installation. Failure to comply may result in serious injury or death to personnel or damage to equipment.

WARNING SUMMARY (CONT)

WARNING

Pump unit weighs approximately 870 lbs (395 kgs). Attach a suitable lifting device prior to installation. Failure to comply may result in serious injury or death to personnel or damage to equipment.

WARNING

Do not remove oil filter while engine is hot. Failure to comply may result in injury to personnel.

WARNING

Starting fluid is toxic and highly flammable. Container is pressurized. NEVER heat container and NEVER discharge starting fluid in confined areas or near open flame. Failure to comply may cause serious injury or death to personnel.

WARNING

Tab of HAND THROTTLE lever must be positioned above throttle pivot bar. Failure to comply may result in injury to personnel or damage to equipment.

WARNING

Use extreme care when opening cab door with cab raised. Failure to comply may result in injury to personnel or damage to equipment.

WARNING

Do not operate vehicle with exhaust pipe removed. Toxic exhaust fumes may enter cab, resulting in serious injury or death to personnel.

WARNING

Radiator and charge air cooler assembly weigh approximately 160 lbs (73 kgs). Attach a suitable lifting device prior to removal. Failure to comply may result in injury to personnel or damage to equipment.

WARNING

Cargo sling must be placed under charge air cooler inlet and outlet ports. Failure to comply may result in injury to personnel or damage to equipment.

WARNING

Alternator weighs approximately 50 lbs (23 kgs). The aid of an assistant is required to remove alternator. Failure to comply may result in injury to personnel.

WARNING

Starting motor weighs approximately 60 lbs (27 kgs). Attach a suitable lifting device prior to removal. Failure to comply may result in injury to personnel or damage to equipment.

WARNING

Negative battery terminals must be connected last. Failure to comply may result in serious injury or death to personnel.

WARNING

Negative battery terminals and battery tester negative terminal lug must be disconnected first. Failure to comply may result in serious injury or death to personnel.

WARNING

Battery box weighs approximately 70 lbs (32 kgs). The aid of two assistants is required to remove battery box from vehicle frame. Failure to comply may result in injury to personnel.

WARNING

Battery box weighs approximately 70 lbs (32 kgs). The aid of two assistants is required to position battery box on vehicle frame. Failure to comply may result in injury to personnel.

WARNING

Ensure WTEC III cab transmission harness does not interfere with throttle linkage. Failure to comply may result in injury to personnel.

WARNING

Self-adjusting brakes will not self-adjust without applying brake pedal. Failure to comply may result in injury to personnel.

WARNING SUMMARY (CONT)

WARNING

Ensure air hoses are connected to correct fittings. Failure to comply may result in serious injury or death to personnel.

WARNING

Proper adjustment of load sensing valve may only be accomplished with vehicle unloaded. Failure to comply may result in injury to personnel or damage to equipment.

WARNING

Always use an inflation safety cage to inflate tires mounted on multipiece rims, and tire/rim assemblies not mounted on a tire changing machine that has a positive lock down device designed to hold the assembly during inflation (TM 9-2610-200-14). When using a tire changing machine, always follow manufacturer's mounting and safety instructions. Failure to comply may result in serious injury or death to personnel. Always inflate tires that are mounted on rims with demountable side ring flanges or lockrings in an inflation safety cage or serious injury or death may result.

WARNING

Tire weighs approximately 350 lbs (159 kgs). Use extreme care when handling tire. Failure to comply may result in injury to personnel.

WARNING

Wheel drum weighs approximately 92 lbs (42 kgs). Use the aid of an assistant to help remove wheel drum from axle. Failure to comply may result in injury to personnel.

WARNING

The sudden release of high pressure air can cause damage to eyes. Wear appropriate eye protection when working near pressurized air. Failure to comply may result in injury to personnel.

WARNING

Leave shackles installed in front bumper to support front bumper until ready to remove. Failure to comply may result in injury to personnel.

WARNING

Front bumper weighs approximately 100 lbs (45 kgs). Use the aid of an assistant to remove front bumper. Failure to comply may result in injury to personnel.

WARNING

Tractor platform weighs approximately 550 lbs (250 kgs). Attach a suitable lifting device prior to removal. Failure to comply may result in injury to personnel or damage to equipment.

WARNING

Spare tire retainer weighs approximately 150 lbs (68 kgs). The aid of two assistants is required to remove spare tire retainer from vehicle. Failure to comply may result in injury to personnel.

WARNING

Rear stabilizer bar weighs approximately 50 lbs (22 kgs). Attach a suitable lifting device prior to removal. Failure to comply may result in injury to personnel or damage to equipment.

WARNING

Cab roof weighs approximately 110 lbs (50 kgs). Attach a suitable lifting device prior to removal. Failure to comply may result in injury to personnel.

WARNING

Use care when removing/installing window. Do not force window, or window may shatter. Failure to comply may result in injury to personnel or damage to equipment.

WARNING

Tailgate assembly weighs approximately 130 lbs (59 kgs). Attach a suitable lifting device prior to removal. Failure to comply may result in injury to personnel or damage to equipment.

WARNING

Tow bar weighs approximately 150 lbs (68 kgs). Attach a suitable lifting device prior to removal. Failure to comply may result in injury to personnel or damage to equipment.

WARNING SUMMARY (CONT)

WARNING

Rear tool box weighs approximately 75 lbs (34 Kgs) empty. Attach a suitable lifting device prior to removal. Failure to comply may result in injury to personnel or damage to equipment.

WARNING

Cable can become frayed or contain broken wires. Wear heavy leather-palmed gloves when handling cable. Frayed or broken wires can injure hands. Failure to comply may result in injury to personnel.

WARNING

Remote control must be used to operate 30K winch while breaking in cables. Failure to comply may result in injury to personnel.

WARNING

Cab weighs approximately 3000 lbs (1362 kgs) attach a suitable lifting device prior to raising cab. Failure to comply may result in injury to personnel.

WARNING

Hydraulic tank weighs approximately 190 lbs (86 kgs). Attach a suitable lifting device prior to removal. Failure to comply may result in injury to personnel or damage to equipment.

WARNING

Extreme care must be taken when lowering gravel deflector. Coolant hoses could be pulled loose. Failure to comply could result in serious eye injury.

WARNING

Retaining rings are under tension and can act as projectiles when released causing severe eye injury. Use care when installing retaining rings. Failure to comply may result in injury to personnel.

WARNING

Do not open coolant fill cap if temperature reads above 110 degrees F (43 degrees C). Steam or hot coolant is under pressure. Failure to comply may result in injury to personnel.

WARNING

Pressure in reservoir tank must be released before removing cap. Failure to comply may result in injury to personnel.

WARNING

200 amp alternator weighs approximately 72 lbs (33 kgs). The aid of an assistant is required to install 200 amp alternator. Failure to comply may result in injury to personnel.

WARNING

100 amp alternator weighs approximately 70 lbs (32 kgs). Attach a suitable lifting device prior to removal. Failure to comply may result in injury to personnel.

WARNING

Both collapsible drums weigh approximately 235 lbs (107 kgs) empty and 3800 lbs (1725 kgs) full each. Attach a suitable lifting device prior to removal. Failure to comply may result in serious injury or death to personnel or damage to equipment.

WARNING

Air dryer may contain air pressure. Loosen input air hose connector slowly to vent off air pressure. Failure to comply may result in injury to personnel.

WARNING

Radiator and charge air cooler assembly weigh approximately 160 lbs (73 Kgs). Attach a suitable lifting device prior to installation. Failure to comply may result in injury to personnel or damage to equipment.

WARNING

Tractor platform weighs approximately 550 lbs (250 kgs). Attach a suitable lifting device prior to installation. Failure to comply may result in injury to personnel or damage to equipment.

WARNING SUMMARY (CONT)

WARNING

Spare tire retainer weighs approximately 150 lbs (68 kgs). The aid of two assistants is required to install spare tire retainer on vehicle. Failure to comply may result in injury to personnel.

WARNING

Rear stabilizer bar weighs approximately 50 lbs (22 kgs). Attach a suitable lifting device prior to installation. Failure to comply may result in injury to personnel or damage to equipment.

WARNING

Cab roof weighs approximately 110 lbs (50 kgs). Attach a suitable lifting device prior to installation. Failure to comply may result in injury to personnel.

WARNING

Do not remove radiator cap when the engine is hot; steam and hot coolant can escape and burn skin. Failure to comply may result in injury to personnel.

WARNING

Wear appropriate eye protection when removing spring rings. Spring rings are under tension and can act as projectiles when being removed. Failure to comply may result in injury to personnel.

WARNING

Wear appropriate eye protection when installing spring rings. Spring rings are under tension and can act as projectiles when being installed. Failure to comply may result in injury to personnel.

LIST OF EFFECTIVE PAGES

Insert latest changed pages. Destroy superseded pages.

NOTE: New or changed material is indicated by a vertical bar in the outer margin of the page.

Dates of issue for original and changed pages are:

Original0..... 15 September 1998
 Change.....1..... 1 July 2003

THE TOTAL NUMBER OF PAGES IN THIS PUBLICATION IS 1328, CONSISTING OF THE FOLLOWING:

Page No.	*Change No.	Page No.	*Change No.	Page No.	*Change No.
Cover.....	1	2-2229 and 2-2230.....	1	2-2415 and 2-2416.....	1
Blank	0	2-2230.1 thru 2-2230.14		2-2416.1 Added.....	1
a thru l.....	0	Added.....	1	2-2416.2 Blank Added	1
m and n.....	1	2-2231 thru 2-2234.....	1	2-2416.3 thru 2-2416.7	
A thru D Added	1	2-2234.1 thru 2-2234.22		Added.....	1
i.....	1	Added.....	1	2-2416.8 Blank Added	1
ii.....	0	2-2235	1	2-2416.9 and 2-2416.10	
iii thru vi.....	1	2-2236 Blank	0	Added.....	1
2-2006.1 Added	1	2-2237	1	2-2417.....	1
2-2006.2 Blank Added.....	1	2-2238 Blank	1	2-2418 Blank.....	0
2-2007 thru 2-2009.....	1	2-2239 thru 2-2242 Deleted	1	2-2419 thru 2-2426	1
2-2010 thru 2-2069.....	0	2-2243 thru 2-2253.....	0	2-2426.1 and 2-2426.2 Added ...	1
2-2070 thru 2-2079.....	1	2-2254	1	2-2427 and 2-2428	1
2-2080 Blank	1	2-2254.1 and 2-2254.2		2-2428.1 thru 2-2428.8 Added... 1	
2-2081 thru 2-2100 Deleted	1	Added.....	1	2-2429 and 2-2430	1
2-2101 Blank	1	2-2255	1	2-2430.1 and 2-2430.8 Added ... 1	
2-2102 and 2-2103.....	1	2-2256 thru 2-2263.....	0	2-2431 and 2-2432	1
2-2104 thru 2-2109.....	0	2-2264	1	2-2432.1 and 2-2432.2 Added ... 1	
2-2110 thru 2-2117.....	1	2-2264.1 and 2-2264.2		2-2433.....	1
2-2118 Blank	1	Added.....	1	2-2434 Blank.....	0
2-2119 Blank	1	2-2265	1	2-2435 thru 2-2439	0
2-2120 and 2-2121.....	1	2-2266 thru 2-2269.....	0	2-2440 Blank.....	0
2-2122 thru 2-2141.....	0	2-2270 Blank	0	2-2441 thru 2-2446	0
2-2142 Blank	0	2-2271	1	2-2446.1 Added.....	1
2-2143	0	2-2272 Blank	1	2-2446.2 Blank Added	1
2-2144 thru 2-2149.....	1	2-2273 thru 2-2370 Deleted	1	2-2447.....	1
2-2150 Blank	0	2-2371 Blank	1	2-2448 and 2-2449.....	0
2-2151 thru 2-2171.....	0	2-2372	1	2-2450 Blank.....	0
2-2172 Blank	0	2-2373 thru 2-2407.....	0	3-1.....	1
2-2173 thru 2-2187.....	0	2-2408 Blank	0	3-2 thru 3-14	0
2-2188 Blank	0	2-2409 thru 2-2411.....	0	3-15 thru 3-17	1
2-2189 thru 2-2203.....	0	2-2412 Blank	0	3-18 and 3-19.....	0
2-2204 Blank	0	2-2413 and 2-2414.....	1	3-20 and 3-21.....	1
2-2205 thru 2-2211.....	0	2-2414.1 Added	1	3-22 Blank	0
2-2212 Blank	0	2-2414.2 Blank Added.....	1	4-1.....	1
2-2213 thru 2-2217.....	0	2-2414.3 thru 2-2414.9		4-2 thru 4-4	0
2-2218 Blank	0	Added.....	1	4-5.....	1
2-2219 thru 2-2228.....	1	2-2414.10 Blank Added	1	4-6 thru 4-8	0
2-2228.1 thru 2-2228.18		2-2414.11 and 2-2414.12		4-9.....	1
Added.....	1	Added.....	1	4-10.....	0

* Zero in this column indicates an original page.

LIST OF EFFECTIVE PAGES (CONT)

Insert latest changed pages. Destroy superseded pages.

Page No.	*Change No.	Page No.	*Change No.	Page No.	*Change No.
4-10.1 and 4-10.2 Added.....	1	6-35 thru 6-38.....	0	7-146.1 Added.....	1
4-11.....	0	6-39.....	1	7-146.2 Blank Added.....	1
4-12 and 4-13.....	1	6-40 thru 6-48.....	0	7-147 thru 7-150.....	0
4-14.....	0	6-49.....	1	7-150.1 Added.....	1
4-15.....	1	6-50 thru 6-52.....	0	7-150.2 Blank Added.....	1
4-16 and 4-17.....	0	6-53.....	1	7-151.....	1
4-18.....	1	6-54 thru 6-66.....	0	7-152 thru 7-158.....	0
4-19 thru 4-41.....	0	6-67.....	1	7-159.....	1
4-42 and 4-43.....	1	6-68 and 6-69.....	0	7-160 thru 7-166.....	0
4-44.....	0	6-70 and 6-71.....	1	7-166.1 Added.....	1
4-45.....	1	6-72.....	0	7-166.2 Blank Added.....	1
4-46.....	0	6-72.1 Added.....	1	7-167.....	1
4-47.....	1	6-72.2 Blank Added.....	1	7-168 thru 7-171.....	0
4-48 thru 4-59.....	0	6-73 thru 6-78.....	1	7-172.....	1
4-60.....	1	7-1 thru 7-6.....	1	7-172.1 Added.....	1
4-61 and 4-62.....	0	7-7 and 7-8.....	0	7-172.2 Blank Added.....	1
4-63.....	1	7-9 thru 7-11.....	1	7-173 thru 7-189.....	0
4-64 thru 4-68.....	0	7-12 thru 7-26.....	0	7-190 thru 7-200.....	1
4-69.....	1	7-27 thru 7-33.....	1	7-200.1 Added.....	1
4-70 thru 4-81.....	0	7-34 thru 7-37.....	0	7-200.2 Blank Added.....	1
4-82 thru 4-84.....	1	7-38.....	1	7-201.....	1
4-85 thru 4-105.....	0	7-38.1 thru 7-38.4 Added.....	1	7-202 thru 7-206.....	0
4-106 Blank.....	0	7-39 thru 7-42.....	0	7-207.....	1
5-1.....	1	7-43.....	1	7-208 and 7-209.....	0
5-2 thru 5-6.....	0	7-44 thru 7-47.....	0	7-210 and 7-211.....	1
5-7 and 5-8.....	1	7-48.....	1	7-212.....	0
5-9.....	0	7-49 thru 7-54.....	0	7-213 thru 7-215.....	1
5-10 and 5-11.....	1	7-55.....	1	7-216 thru 7-218.....	0
5-12 and 5-13.....	0	7-56 thru 7-59.....	0	7-219 and 7-220.....	1
5-14 and 5-15.....	1	7-60.....	1	7-221.....	0
5-16 Blank.....	0	7-61 thru 7-67.....	0	7-222 thru 7-230.....	1
6-1 thru 6-3.....	1	7-68.....	1	7-231 thru 7-241.....	0
6-4.....	0	7-69 thru 7-72.....	0	7-242.....	1
6-4.1 and 6-4.2 Added.....	1	7-73.....	1	7-242.1 Added.....	1
6-5.....	1	7-74 thru 7-79.....	0	7-242.2 Blank Added.....	1
6-6.....	0	7-80.....	1	7-243 thru 7-247.....	1
6-7.....	1	7-81 thru 7-83.....	0	7-248 thru 7-253.....	0
6-8 and 6-9.....	0	7-84.....	1	7-254.....	1
6-10 thru 6-13.....	1	7-85 thru 7-91.....	0	7-255.....	0
6-14.....	0	7-92.....	1	7-256.....	1
6-15 thru 6-18.....	1	7-93.....	0	7-257 thru 7-274.....	0
6-19.....	0	7-94.....	1	7-275 and 7-276.....	1
6-20 thru 6-24.....	1	7-95 thru 7-108.....	0	7-277 and 7-278.....	0
6-24.1 Added.....	1	7-109.....	1	7-279.....	1
6-24.2 Blank Added.....	1	7-110 thru 7-123.....	0	7-280.....	0
6-25.....	1	7-124.....	1	7-281 thru 7-286.....	1
6-26 and 6-27.....	0	7-125 thru 7-137.....	0	7-286.1 and 7-286.2 Added.....	1
6-28.....	1	7-138.....	1	7-287 thru 7-289.....	1
6-29 thru 6-33.....	0	7-139 thru 7-145.....	0	7-290 thru 7-295.....	0
6-34.....	1	7-146.....	1	7-296 thru 7-300.....	1

* Zero in this column indicates an original page.

LIST OF EFFECTIVE PAGES (CONT)

Insert latest changed pages. Destroy superseded pages.

Page No.	*Change No.	Page No.	*Change No.	Page No.	*Change No.
7-301 thru 7-305.....	0	H-21.....	1	FO-1 FP-40 Blank	0
7-306 thru 7-314.....	1	H-22 thru H-25.....	0	FO-1 FP-41.....	1
7-315	0	H-26 thru H-28.....	1	FO-1 FP-42 Blank	0
7-316	1	H-29 and H-30	0	FO-1 FP-43.....	1
7-317 thru 7-319.....	0	H-31 and H-32.....	1	FO-1 FP-44 Blank	0
7-320 and 7-321	1	J-1	0	FO-1 FP-45.....	1
7-322	0	J-2 Blank.....	0	FO-1 FP-46 Blank	0
7-323	1	K-1 thru K-4 Added	1	FO-1 FP-47.....	1
7-324 thru 7-335.....	0	INDEX-1 thru INDEX-13.....	1	FO-1 FP-48 Blank	0
7-336 and 7-337	1	INDEX-14 Blank.....	1	FO-1 FP-49.....	1
7-338 thru 7-345.....	0	Glossary-1 and Glossary-2.....	0	FO-1 FP-50 Blank	0
7-346	1	FO-1 FP-1	1	FO-1 FP-51.....	1
7-347 thru 7-351	0	FO-1 FP-2 Blank	0	FO-1 FP-52 Blank	0
7-352 and 7-353	1	FO-1 FP-3.....	1	FO-1 FP-53.....	1
7-354	0	FO-1 FP-4 Blank	0	FO-1 FP-54 Blank	0
7-355	1	FO-1 FP-5.....	1	FO-1 FP-55.....	1
7-356 thru 7-361	0	FO-1 FP-6 Blank	0	FO-1 FP-56 Blank	0
7-362 Blank.....	0	FO-1 FP-7	1	FO-1 FP-57.....	1
A-1.....	0	FO-1 FP-8 Blank	0	FO-1 FP-58 Blank	0
A-2 and A-3.....	1	FO-1 FP-9.....	1	FO-1 FP-59.....	1
A-4.....	0	FO-1 FP-10 Blank	0	FO-1 FP-60 Blank	0
B-1 thru B-3.....	0	FO-1 FP-11	1	FO-1 FP-61.....	1
B-4.....	1	FO-1 FP-12 Blank	0	FO-1 FP-62 Blank	0
B-5 thru B-23	0	FO-1 FP-13	1	FO-1 FP-63.....	1
B-24 thru B-29.....	1	FO-1 FP-14 Blank	0	FO-1 FP-64 Blank	0
B-30 Blank	1	FO-1 FP-15	1	FO-1 FP-65.....	1
C-1.....	0	FO-1 FP-16 Blank	0	FO-1 FP-66 Blank	0
C-2 thru C-4.....	1	FO-1 FP-17	1	FO-1 FP-67.....	1
D-1 thru D-6.....	1	FO-1 FP-18 Blank	0	FO-1 FP-68 Blank	0
D-7 Added.....	1	FO-1 FP-19	1	FO-1 FP-69.....	0
D-8 Blank Added.....	1	FO-1 FP-20 Blank	0	FO-1 FP-70 Blank	0
E-1.....	1	FO-1 FP-21	1	FO-1 FP-71.....	0
E-2 and E-3.....	0	FO-1 FP-22 Blank	0	FO-1 FP-72 Blank	0
E-4 and E-5	1	FO-1 FP-23	0	FO-1 FP-73.....	0
E-6 thru E-14	0	FO-1 FP-24 Blank	0	FO-1 FP-74 Blank	0
E-15.....	1	FO-1 FP-25	1	FO-1 FP-75.....	1
E-16 thru E-26.....	0	FO-1 FP-26 Blank	0	FO-1 FP-76 Blank	0
E-27 thru E-31 Added.....	1	FO-1 FP-27	0	FO-1 FP-77.....	1
E-32 Blank Added.....	1	FO-1 FP-28 Blank	0	FO-1 FP-78 Blank	0
F-1 thru F-8	0	FO-1 FP-29	1	FO-1 FP-79.....	1
G-1 thru G-12	1	FO-1 FP-30 Blank	0	FO-1 FP-80 Blank	0
H-1.....	0	FO-1 FP-31	1	FO-2 FP-1.....	0
H-2 and H-3.....	1	FO-1 FP-32 Blank	0	FO-2 FP-2 Blank	0
H-4.....	0	FO-1 FP-33	1	FO-2 FP-3.....	0
H-5.....	1	FO-1 FP-34 Blank	0	FO-2 FP-4 Blank	0
H-6 and H-7.....	0	FO-1 FP-35	1	FO-2 FP-5.....	0
H-8.....	1	FO-1 FP-36 Blank	0	FO-2 FP-6 Blank	0
H-9.....	0	FO-1 FP-37	1	FO-2 FP-7.....	0
H-10 and H-11	1	FO-1 FP-38 Blank	0	FO-2 FP-8 Blank	0
H-12 thru H-20.....	0	FO-1 FP-39	1	FO-3 FP-1.....	0

* Zero in this column indicates an original page.

LIST OF EFFECTIVE PAGES (CONT)

Insert latest changed pages. Destroy superseded pages.

Page No.	*Change No.	Page No.	*Change No.	Page No.	*Change No.
FO-3 FP-2 Blank	0				
FO-3 FP-3	0				
FO-3 FP-4 Blank	0				
FO-3 FP-5	0				
FO-3 FP-6 Blank	0				
FO-3 FP-7	0				
FO-3 FP-8 Blank	0				
FO-3 FP-9	0				
FO-3 FP-10 Blank	0				
FO-3 FP-11	0				
FO-3 FP-12 Blank	0				
FO-3 FP-13	0				
FO-3 FP-14 Blank	0				
FO-3 FP-15	0				
FO-3 FP-16 Blank	0				
FO-4 FP-1	0				
FO-4 FP-2 Blank	0				
FO-4 FP-3	0				
FO-4 FP-4 Blank	0				
FO-5 FP-1	0				
FO-5 FP-2 Blank	0				
FO-5 FP-3	0				
FO-5 FP-4 Blank	0				
FO-5 FP-5	0				
FO-5 FP-6 Blank	0				

* Zero in this column indicates an original page.

TECHNICAL MANUAL
 NO. 9-2320-366-20-3

TECHNICAL ORDER
 NO. 36A12-1C-1102-

Washington, D.C., 15 September 1998

Unit Maintenance Manual
**M1083 SERIES, 5-TON, 6 x 6,
 MEDIUM TACTICAL VEHICLES (MTV)**
 VOLUME NO. 3 OF 5

MODEL	NSN	EIC
TRK, CAR., MTV, M1083 W/WN W/O WN	2320-01-360-1895 2320-01-354-3386	BT3 BR2
TRK, CAR., MTV, W/MATL HDLG EQPT (MHE), M1084	2320-01-354-3387	BR3
TRK, CAR., MTV, LWB, M1085 W/WN W/O WN	2320-01-360-1897 2320-01-354-4530	BT5 BR7
TRK, CAR., MTV, LWB, W/MATL HDLG EQPT (MHE), M1086	2320-01-354-4531	BR8
TRK, TRACTOR, MTV, M1088 W/WN W/O WN	2320-01-360-1892 2320-01-355-4332	BTY BTJ
TRK, WKR, MTV, M1089	2320-01-354-4528	BR4
TRK, DUMP, MTV, M1090 W/WN W/O WN	2320-01-360-1893 2320-01-354-4529	BTZ BR5
TRK, CHAS, MTV, M1092	2320-01-354-3382	BRZ
TRK, CAR., MTV, AIR DROP, M1093 W/WN W/O WN	2320-01-360-1896 2320-01-355-3063	BT4 BR9
TRK, DUMP, MTV, AIR DROP, M1094 W/WN W/O WN	2320-01-360-1984 2320-01-355-3062	BT2 BTK
TRK, CHAS, MTV, LWB, M1096	2320-01-354-4527	BR6

REPORTING ERRORS AND RECOMMENDING IMPROVEMENTS

You can help improve this publication. If you find any mistakes or if you know of a way to improve the procedures, please let us know. Submit your DA Form 2028 (Recommended Changes to Equipment Technical Publications), through the Internet, on the Army Electronic Product Support (AEPS) website. The Internet address is <http://aeps.ria.army.mil>. If you need a password, scroll down and click on "ACCESS REQUEST FORM". The DA Form 2028 is located in the ONLINE FORMS PROCESSING section of the AEPS. Fill out the form and click on SUBMIT. Using this form on the AEPS will enable us to respond quicker to your comments and better manage the DA Form 2028 program. You may also mail, fax or Email your letter or DA Form 2028 direct to: AMSTA-LC-CI/TECH PUBS, TACOM-RI, 1 Rock Island Arsenal, Rock Island, IL 61299-7630. The email address is TACOM-TECH-PUBS@ria.army.mil. The fax number is DSN 793-0726 or Commercial (309) 782-0726.

DISTRIBUTION STATEMENT A. Approved for public release; distribution is unlimited.

TABLE OF CONTENTS

	Page
HOW TO USE THIS MANUAL	iii
CENTRAL TIRE INFLATION SYSTEM (CTIS) TROUBLESHOOTING	2-2007
AXLE TROUBLESHOOTING	2-2143
STEERING TROUBLESHOOTING	2-2151
FIFTH WHEEL TROUBLESHOOTING	2-2173
SUSPENSION SYSTEM TROUBLESHOOTING	2-2189
15K SELF-RECOVERY WINCH (SRW) SYSTEM TROUBLESHOOTING	2-2205
STEERING HYDRAULIC SYSTEM TROUBLESHOOTING	2-2213
AIR TRANSPORT TROUBLESHOOTING	2-2219
DUMP BODY HYDRAULIC SYSTEM TROUBLESHOOTING	2-2237
WRECKER HYDRAULIC SYSTEM TROUBLESHOOTING	2-2243
SPECIAL PURPOSE KIT TROUBLESHOOTING	2-2271
M1084/M1086 MATERIAL HANDLING CRANE (MHC) TROUBLESHOOTING	2-2409
CAB TILT AND SPARE TIRE RETAINER TROUBLESHOOTING	2-2413
M1089 AIR SYSTEM TROUBLESHOOTING	2-2419
FRAME TROUBLESHOOTING	2-2435
CHAPTER 3 ENGINE MAINTENANCE	3-1
Section I Introduction	3-1
Section II Maintenance Procedures	3-2

CHAPTER 4 FUEL SYSTEM MAINTENANCE	4-1
Section I Introduction	4-1
Section II Maintenance Procedures	4-2

CHAPTER 5 EXHAUST SYSTEM MAINTENANCE	5-1
Section I Introduction	5-1
Section II Maintenance Procedures	5-2

CHAPTER 6 COOLING SYSTEM MAINTENANCE	6-1
Section I Introduction	6-1
Section II Maintenance Procedures	6-2

CHAPTER 7 ELECTRICAL SYSTEM MAINTENANCE	7-1
Section I Introduction	7-2
Section II Maintenance Procedures	7-5

APPENDIXES

A. REFERENCES	A-1
B. MAINTENANCE ALLOCATION CHART	B-1
C. TOOLS IDENTIFICATION LIST	C-1
D. EXPENDABLE/DURABLE SUPPLIES AND MATERIALS LIST	D-1
E. ILLUSTRATED LIST OF MANUFACTURED ITEMS	E-1
F. TORQUE LIMITS	F-1
G. MANDATORY REPLACEMENT PARTS	G-1
H. LUBRICATION ORDER	H-1
J. ADDITIONAL AUTHORIZATION LIST (AAL)	J-1
K. TRANSMISSION/TRANSMISSION CONTROLS ADAPTABILITY CHART	K-1

SUBJECT INDEX	Index-1
GLOSSARY	Glossary-1

LIST OF ILLUSTRATIONS

Figure No.	Figure Title	Page
7-1.	Power Distribution Panel (PDP) Circuit Beakers, Diodes, and Relays	7-38
E-1.	Brake Adjusting Tool Support	E-5
E-2.	Brake Plunger Seal Driver	E-6
E-3.	Cab Support Tool Strut and Cab Rest	E-7
E-4.	Cab Support Tool Seat	E-8
E-5.	Cab Support Tool Seat Layout	E-9
E-6.	Cab Support Tool Assembly	E-10
E-7.	Dump Body Lifting Bracket	E-11
E-8.	Rear, Top, and Guide Plate	E-12
E-9.	Front and Mounting Plate	E-13
E-10.	Headlight Adjustment Screen	E-14
E-11.	M1089 30K Winch Test Adapter	E-15

Figure No.	Figure Title	Page
E-12.	M1089 Solenoid Test Adapter	E-16
E-13.	Not Used	
E-14.	Lanyard Assembly	E-23
E-15.	CTIS Seal Driver	E-25
E-16.	Wheel Hub Grease Seal Driver	E-26
E-17.	Purge Valve Tool	E-28
E-18.	M1089 30K Winch Pneumatic Test Adapter	E-31

LIST OF TABLES

Table No.	Table Title	Page
2-52.	Central Tire Inflation System (CTIS) Fault Index	2-2007
2-53.	Axle Fault Index	2-2143
2-54.	Steering Fault Index	2-2151
2-55.	Fifth Wheel Fault Index	2-2173
2-56.	Suspension System Fault Index	2-2189
2-57.	15K Self-Recovery Winch (SRW) System Fault Index	2-2205
2-58.	Steering Hydraulic System Fault Index	2-2213
2-59.	Air Transport Components Fault Index	2-2219
2-60.	Dump Body Hydraulic System Fault Index	2-2237
2-61.	Wrecker Hydraulic System Fault Index	2-2243
2-62.	Special Purpose Kit Fault Index	2-2271
2-63.	M1084/M1086 Material Handling Crane (MHC) Hydraulic Fault Index	2-2409
2-64.	Cab Tilt and Spare Tire Retainer Fault Index	2-2413
2-65.	M1089 Air System Fault Index	2-2419
2-65.1.	30K Winch Freespool Solenoid Valve	2-2421
2-65.2.	30K Winch Pneumatic Manifold Drum Tensioner Solenoids	2-2430.5
2-66.	Wrecker Function Solenoid Valve	2-2432.1
2-67.	Deleted	
2-68.	Frame Fault Index	2-2435
7-1.	Power Distribution Panel (PDP) Relays	7-39
7-1.1.	Power Distribution Panel (PDP) Circuit Breakers	7-40
7-1.2.	Electrical Gages Connectors	7-94
7-2.	Rocker Switch Connectors	7-95
7-3.	M1093/M1094 Cab Clearance and Marker Lights Connectors	7-307
7-4.	Cab Clearance Marker Light Connectors	7-322
E-1.	Pneumatic Tube Lengths	E-17
E-2.	Non-Metallic Electrical Cable Conduit Lengths	E-21
E-3.	M1089 30K Air Hose Lengths and Fittings	E-29
F-1.	Dry Torque Limits for SAE and ANSI Screws and Free Spinning Nuts	F-2
F-2.	Dry Torque Limits for SAE and ANSI Prevailing Torque Nuts	F-4
F-3.	Dry Torque Limits for Metric Screws and Free Spinning Nuts	F-5
F-4.	Dry Torque Limits for Metric Prevailing Torque Nuts	F-6
F-5.	Wet Torque Limits for SAE and ANSI Screws and Free Spinning Nuts	F-7

HOW TO USE THIS MANUAL

OVERVIEW

This Technical Manual (TM) is provided to help you maintain the MTV at the Unit Maintenance level. Because of its size, it is divided into five volumes. Volume 3 contains the following major sections in order of appearance:

- **WARNING SUMMARY.** Provides a summary of the most important warnings that apply throughout the manual.
- **CHAPTER 2, TROUBLESHOOTING (CONT)**
- **CHAPTER 3, ENGINE MAINTENANCE**
- **CHAPTER 4, FUEL SYSTEM MAINTENANCE**
- **CHAPTER 5, EXHAUST SYSTEM MAINTENANCE**
- **CHAPTER 6, COOLING SYSTEM MAINTENANCE**
- **CHAPTER 7, ELECTRICAL SYSTEM MAINTENANCE**
- **APPENDIX A, REFERENCES.** Lists publications used with the MTV.
- **APPENDIX B, MAINTENANCE ALLOCATION CHART.** The maintenance allocation chart denotes the level of maintenance which performs specific maintenance tasks and the time required. It also lists tools and special tools required for each task.
- **APPENDIX C, TOOLS IDENTIFICATION LIST.** Lists equipment used in the performance of maintenance and references publications which contain information regarding the equipment.
- **APPENDIX D, EXPENDABLE/DURABLE SUPPLIES AND MATERIALS LIST.** Lists expendable and durable items used in the performance of maintenance.
- **APPENDIX E, ILLUSTRATED LIST OF MANUFACTURED ITEMS.** Illustrates and describes items that must be fabricated from bulk materials for repair of the MTV.
- **APPENDIX F, TORQUE LIMITS.** Lists the standard torque values for specific attaching hardware.
- **APPENDIX G, MANDATORY REPLACEMENT PARTS.**
- **APPENDIX H, LUBRICATION ORDER.**
- **APPENDIX J, ADDITIONAL AUTHORIZATION LIST (AAL).**
- **APPENDIX K, TRANSMISSION/TRANSMISSION CONTROLS ADAPTABILITY CHART.** Lists actions required to mate different transmission configurations with WTEC II or WTEC III controls.
- **SUBJECT INDEX.** Lists important subjects contained in volume 3 in alphabetical order and gives the associated paragraph number.

FINDING INFORMATION

There are several ways to find the information you need in this manual. They are as follows:

- **FRONT COVER INDEX.** The front cover index contains a list of the most important topics contained in each volume. It features a black box at the right edge of the cover which corresponds with a black box on the page containing the topic. The topics listed on the front cover are highlighted in the table of contents with a box.
- **TABLE OF CONTENTS.** Lists chapters, sections, appendixes, and indexes with page numbers in order of appearance.
- **CHAPTER INDEXES.** List paragraphs contained in the individual chapters with paragraph and page numbers in order of appearance.
- **SYMPTOM INDEX.** Lists malfunctions contained in the troubleshooting table with page numbers in order of appearance.

TROUBLESHOOTING

Troubleshooting is contained in chapter 2. When a malfunction occurs, look at the symptom index for the vehicle troubleshooting table in chapter 2. Find the malfunction in the index. Turn to the page number listed for the malfunction in the troubleshooting table. Perform the steps required to correct the malfunction. If you can't find the malfunction, or the malfunction is not corrected, notify your supervisor.

MAINTENANCE

- **SCHEDULED MAINTENANCE.** Your scheduled maintenance is located in Volume 1, table 2-1, PMCS. These checks and services are mandatory at the intervals listed. Always follow the WARNINGS and CAUTIONS.
- **UNSCHEDULED MAINTENANCE.** Unscheduled maintenance is located in chapters 3 through 24. The PMCS and troubleshooting tables often reference you to these procedures. When you perform maintenance, look over the entire procedure before starting. Make sure you have the necessary tools and materials at hand. Always follow the WARNINGS and CAUTIONS.

FOLLOW THESE GUIDELINES WHEN USING THIS MANUAL:

- Become familiar with the entire maintenance procedure before beginning a maintenance task.
- Read all **WARNINGS** and **CAUTIONS** before performing any procedures.

CHAPTER 2 VEHICLE MAINTENANCE (CONT)

2-24. CENTRAL TIRE INFLATION SYSTEM (CTIS) TROUBLESHOOTING	2-2007
2-25. AXLE TROUBLESHOOTING	2-2143
2-26. STEERING TROUBLESHOOTING	2-2151
2-27. FIFTH WHEEL TROUBLESHOOTING	2-2173
2-28. SUSPENSION SYSTEM TROUBLESHOOTING	2-2189
2-29. 15K SELF-RECOVERY WINCH (SRW) SYSTEM TROUBLESHOOTING	2-2205
2-30. STEERING HYDRAULIC SYSTEM TROUBLESHOOTING	2-2213
2-31. AIR TRANSPORT TROUBLESHOOTING	2-2219
2-32. DUMP BODY HYDRAULIC SYSTEM TROUBLESHOOTING	2-2237
2-33. WRECKER HYDRAULIC SYSTEM TROUBLESHOOTING	2-2243
2-34. SPECIAL PURPOSE KIT TROUBLESHOOTING	2-2271
2-35. M1084/M1086 MATERIAL HANDLING CRANE (MHC) HYDRAULIC TROUBLESHOOTING ...	2-2409
2-36. CAB TILT AND SPARE TIRE RETAINER TROUBLESHOOTING	2-2413
2-37. M1089 AIR SYSTEM TROUBLESHOOTING	2-2419
2-38. FRAME TROUBLESHOOTING	2-2435
 Section V. MAINTENANCE PROCEDURES	 2-2441
2-39. MAINTENANCE INTRODUCTION	2-2441
2-40. GROUND HANDLING	2-2441
2-41. GENERAL REMOVAL INSTRUCTIONS	2-2441
2-42. GENERAL DISASSEMBLY INSTRUCTIONS	2-2442
2-43. GENERAL CLEANING INSTRUCTIONS	2-2443
2-44. GENERAL INSPECTION INSTRUCTIONS	2-2446
2-45. GENERAL REPAIR INSTRUCTIONS	2-2446
2-46. GENERAL ASSEMBLY INSTRUCTIONS	2-2447
2-47. GENERAL INSTALLATION INSTRUCTIONS	2-2448
2-48. PREPARATION FOR STORAGE OR SHIPMENT INTRODUCTION	2-2448
2-49. PREPARATION FOR STORAGE OR SHIPMENT	2-2448
2-50. STORAGE MAINTENANCE PROCEDURES	2-2449

2-24. CENTRAL TIRE INFLATION SYSTEM (CTIS) TROUBLESHOOTING

This paragraph covers Central Tire Inflation System (CTIS) Troubleshooting. The Central Tire Inflation System (CTIS) Fault Index, Table 2-52, lists faults for the CTIS System of the vehicle.

Table 2-52. Central Tire Inflation System (CTIS) Fault Index

Fault No.	Description	Page
m1.	Two Steady Mode Lights Illuminate on Central Tire Inflation System (CTIS) ECU	2-2008
m2.	Four CTIS ECU Indicator Lights Flashing	2-2042
m3.	Five Central Tire Inflation System (CTIS) ECU Indicator Lights Flashing	2-2070
m4.	CTIS Repeatedly Resumes Cycling 30 Seconds After Indicator Lights Stop Flashing	2-2104
m5.	Central Tire Inflation System (CTIS) ECU Indicates No Fault Code But System Fails to Inflate or Deflate	2-2110
m6.	No Overspeed Warning Light and/or Overspeed Pressure Change	2-2122

m1. TWO STEADY MODE LIGHTS ILLUMINATE ON CENTRAL TIRE INFLATION SYSTEM (CTIS) ECU

INITIAL SETUP

Equipment Conditions

Engine shut down (TM 9-2320-366-10-1).

Materials/Parts

Soap, Laundry (Item 63, Appendix D)

Personnel Required

(2)

Tools and Special Tools

Materials/Parts
 Tool Kit, Genl Mech (Item 46, Appendix C)
 Goggles, Industrial (Item 15, Appendix C)
 Trestle, Motor Vehicle Maintenance (2)
 (Item 47, Appendix C)
 Pan, Wash (Item 25, Appendix C)
 Wrench, Torque, 0-200 lb-in. (Item 59, Appendix C)

KNOWN INFO
Nothing
POSSIBLE PROBLEMS
Faulty air hose from wet tank to manifold valve assembly. Faulty air compressor or governor adjustment. Faulty wheel valve venting. Faulty manifold valve assembly relief valve. Faulty manifold valve assembly. Faulty quick release valve(s). Faulty rear axle quick release valve fittings. Faulty intermediate axle quick release valve fittings. Faulty intermediate axle tee fittings. Faulty front quick release valve fittings. Faulty front tee fittings. Faulty manifold valve assembly delivery port fittings. Faulty cab floor supply hose fittings. Faulty supply hoses from quick release valve(s) to wheel valve(s). Faulty wheel valve filters. Faulty electrical connections at CTIS ECU and manifold valve assembly. Faulty CTIS ECU.

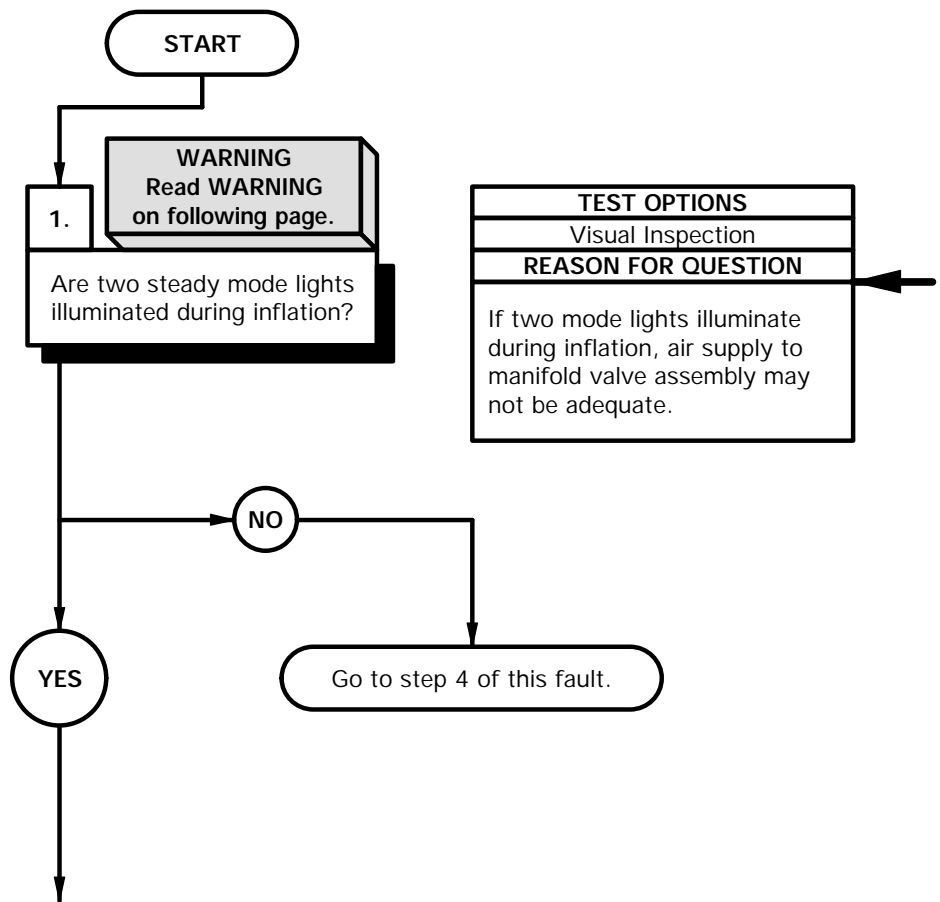

WARNING

Wear appropriate eye protection when working under vehicle due to the possibility of falling debris. Failure to comply may result in injury to personnel.

NOTE

Two steady mode lights are an indication that the CTIS has disconnected operation because of particular inflation or deflation sequence has taken longer than limits allow (40 minutes for inflate; 20 minutes for deflate).

Two steady mode lights indicates that system shut off with air pressure between modes.

The CTIS may still operate including modes that are illuminated by manually pressing the desired mode.

To perform deflate or inflate checks throughout this task, it will be necessary to perform the opposite function first from time to time so that a desired mode selection is available.

- (1) Start engine (TM 9-2320-366-10-1).
- (2) Select an inflation mode on CTIS ECU (TM 9-2320-366-10-1) and determine if two light mode is displayed.
- (3) Select RUN FLAT mode or shut down engine and restart engine (TM 9-2320-366-10-1) again to reset ECU.
- (4) Select a deflation mode on CTIS ECU (TM 9-2320-366-10-1) and determine if two light mode is displayed.
- (5) Shut down engine (TM 9-2320-266-10-1).
- (6) If two steady light mode lights do not illuminate during inflation, go to step 4 of this fault.

m1. TWO STEADY MODE LIGHTS ILLUMINATE ON CENTRAL TIRE INFLATION SYSTEM (CTIS) ECU (CONT)

KNOWN INFO
Two steady mode lights illuminate during inflation.
POSSIBLE PROBLEMS
Faulty air hoses from wet tank to manifold valve assembly.
Faulty air compressor or governor adjustment.
Faulty wheel valve venting.
Faulty manifold valve assembly relief valve.
Faulty manifold valve assembly.
Faulty quick release valve(s).
Faulty rear axle quick release valve fittings.
Faulty intermediate axle quick release valve fittings.
Faulty intermediate axle tee fittings.
Faulty front quick release valve fittings.
Faulty front tee fittings.
Faulty manifold valve assembly delivery port fittings.
Faulty cab floor supply hose fittings.
Faulty supply hoses from quick release valve(s) to wheel valve(s).
Faulty wheel valve filters.
Faulty electrical connections at CTIS ECU and manifold valve assembly.
Faulty ECU.

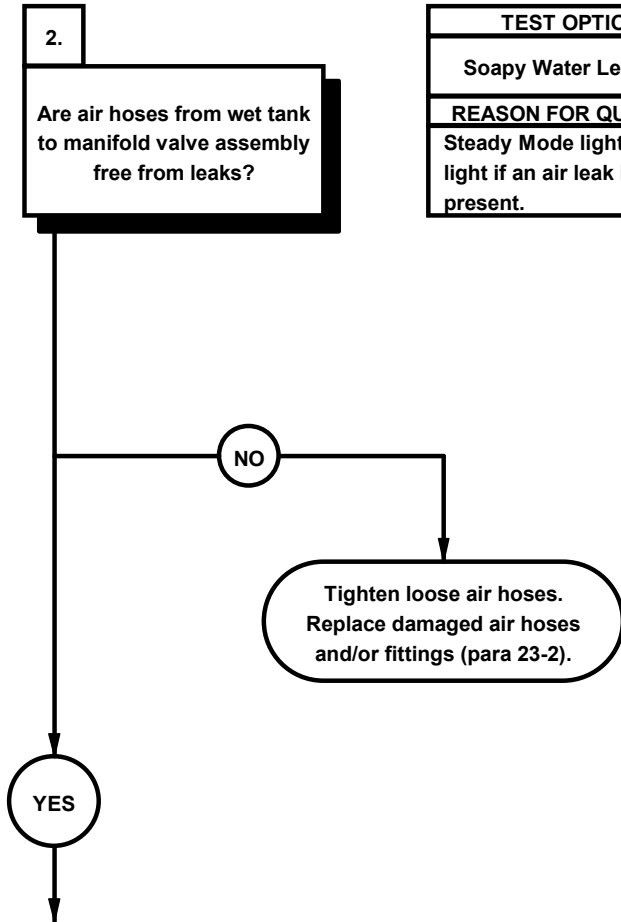

TEST OPTIONS
Soapy Water Leak Test
REASON FOR QUESTION
Steady Mode lights may light if an air leak is present.



NOTE

- Two steady mode lights are an indication that the CTIS has discontinued operation because a particular inflate or deflate sequence has taken longer than limits allow (40 minutes for inflate; 20 minutes for deflate).
- Two steady mode lights indicate that CTIS is shut off with air pressure between modes.
- The CTIS may still operate including modes that are lit, by manually pressing the desired mode.
- To perform deflate or inflate checks throughout this task, it may be necessary to perform the opposite function first so that a desired mode selection is available.

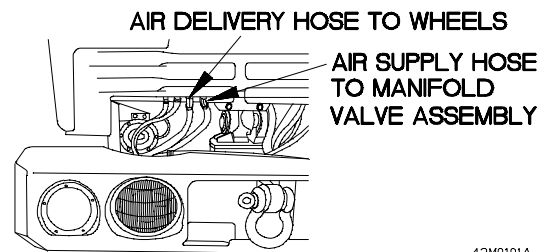
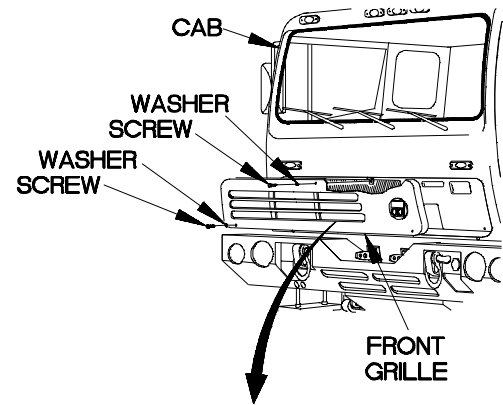
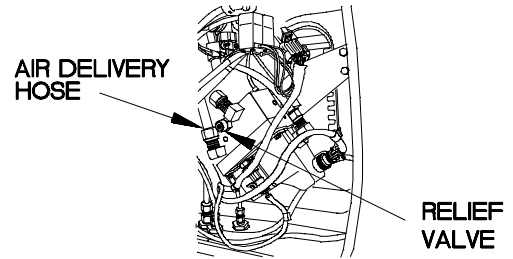

42M0101A

SOAPY WATER LEAK TEST

- (1) Remove kick panel (para 16-3).
- (2) Apply soapy water solution to supply air hose fitting at manifold valve assembly.
- (3) Check for air escaping at manifold valve assembly, indicated by air bubbles.
- (4) Remove two screws and washers from front grille.
- (5) Remove screw and washer from front grille.
- (6) Remove front grille from cab.
- (7) Apply soapy water solution to supply air hose from wet tank at cab floor.
- (8) Check for air escaping at cab floor fittings, indicated by air bubbles.

m1. TWO STEADY MODE LIGHTS ILLUMINATE ON CENTRAL TIRE INFLATION SYSTEM (CTIS) ECU (CONT)

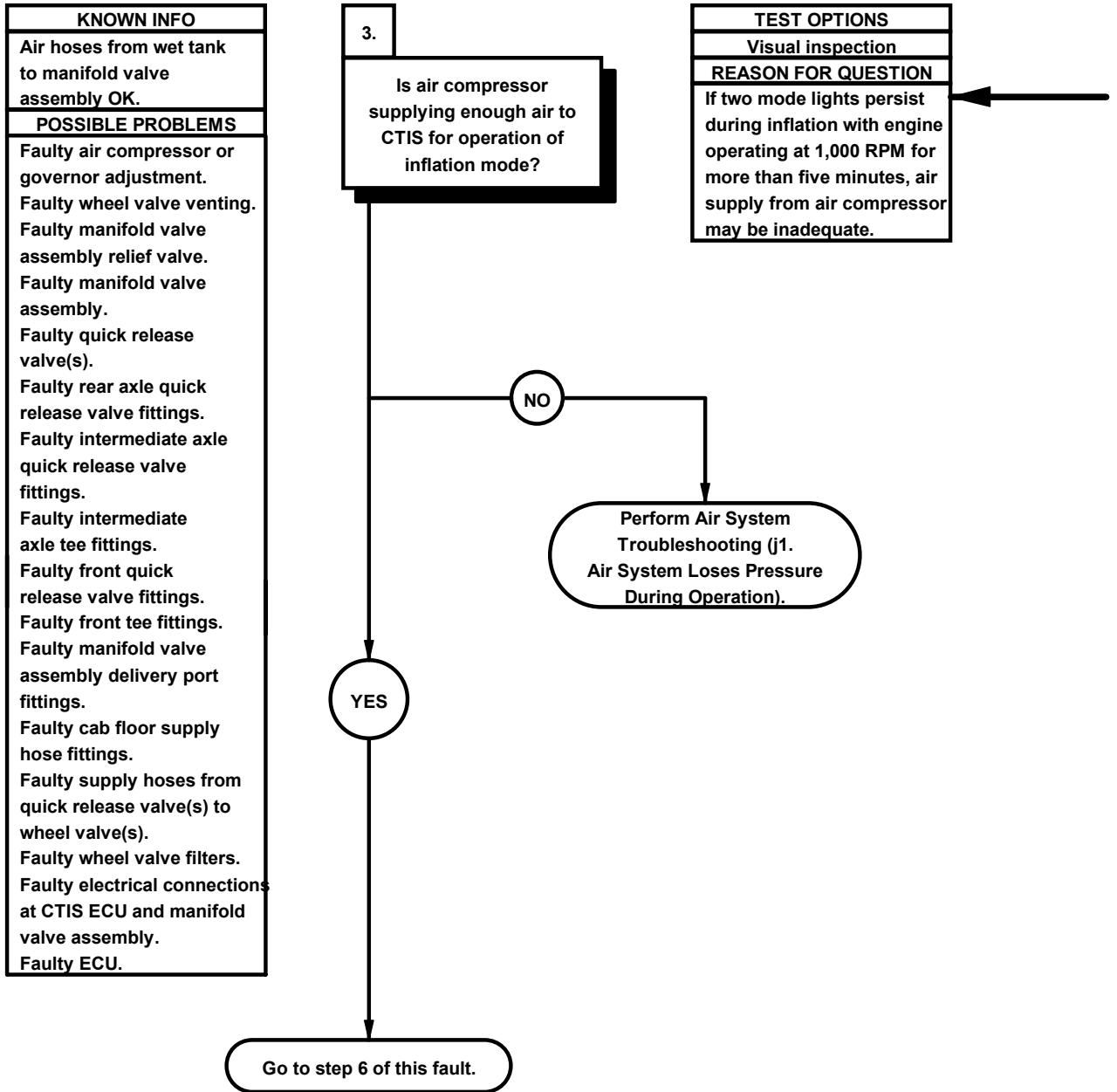

- (1) Start engine (TM 9-2320-366-10-1) and operate at 1,000 RPM for five minutes.
- (2) Select an inflation mode at CTIS ECU and check if two steady mode light returns.
- (3) Apply and release brakes once or twice and check if pressure gages are slow to reach 120 psi.
- (4) If two steady mode lights remain illuminated and brake air pressure gages are slow to reach 120 psi, Perform Air System Troubleshooting (j1. Air System Loses Pressure During Operation).
- (5) Shut down engine (TM 9-2320-366-10-1).

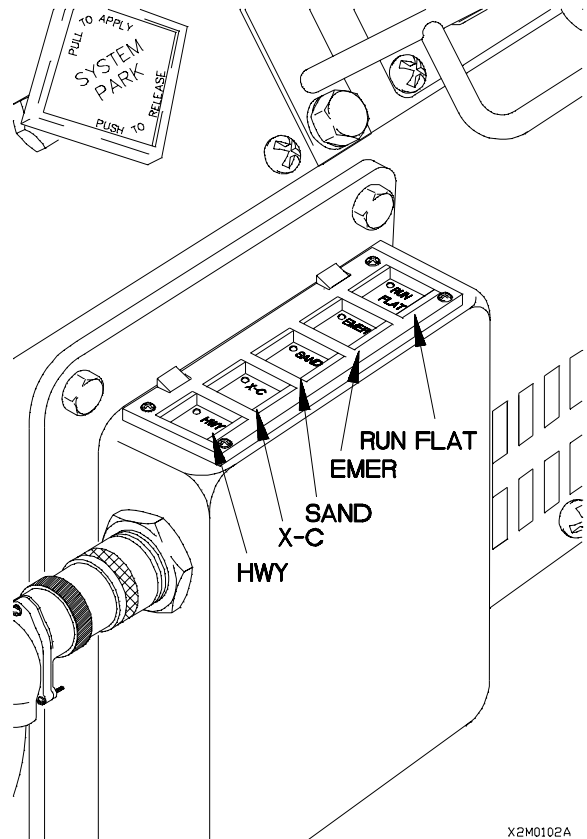

m1. TWO STEADY MODE LIGHTS ILLUMINATE ON CENTRAL TIRE INFLATION SYSTEM (CTIS) ECU (CONT)

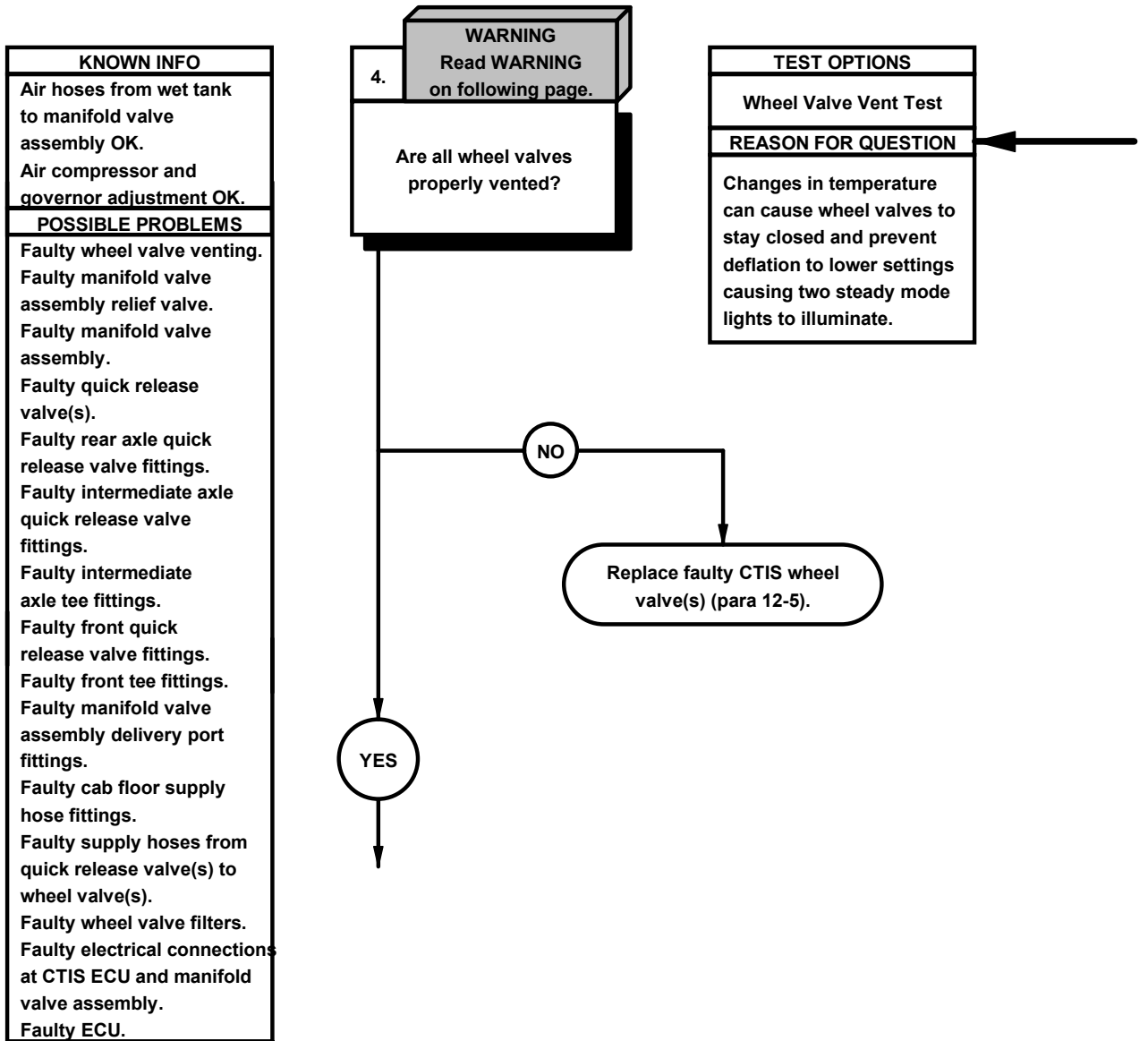

WARNING

Do not loosen screw on wheel valve while CTIS is in use. Failure to comply may result in injury to personnel.

NOTE

At high temperatures, air pressure increases in cap chamber of wheel valve, adding to spring pressure so that valve cannot open to allow tire deflation to lower settings.

WHEEL VALVE VENT TEST

- (1) Release air from all CTIS wheel valves by backing off vent screws approximately three turns.
- (2) If CTIS wheel valve fails to release air, replace CTIS wheel valve (para 12-5).
- (3) Tighten vent screws. Do not overtighten.

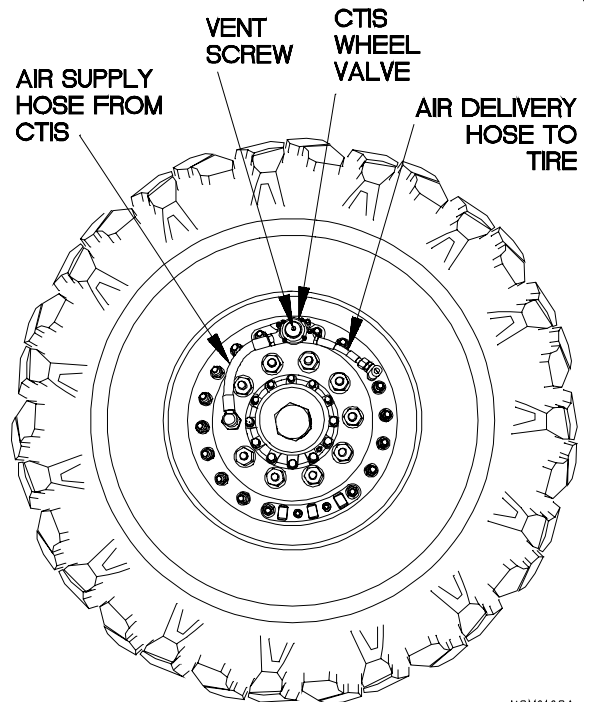

X2M0103A

m1. TWO STEADY MODE LIGHTS ILLUMINATE ON CENTRAL TIRE INFLATION SYSTEM (CTIS) ECU (CONT)

KNOWN INFO
Air hoses from wet tank to manifold valve assembly OK. Air compressor and governor adjustment OK. Wheel valves venting OK.
POSSIBLE PROBLEMS
Faulty manifold valve assembly relief valve. Faulty manifold valve assembly. Faulty quick release valve(s). Faulty rear axle quick release valve fittings. Faulty intermediate axle quick release valve fittings. Faulty intermediate axle tee fittings. Faulty front quick release valve fittings. Faulty front tee fittings. Faulty manifold valve assembly delivery port fittings. Faulty cab floor supply hose fittings. Faulty supply hoses from quick release valve(s) to wheel valve(s). Faulty wheel valve filters. Faulty electrical connections at CTIS ECU and manifold valve assembly. Faulty ECU.

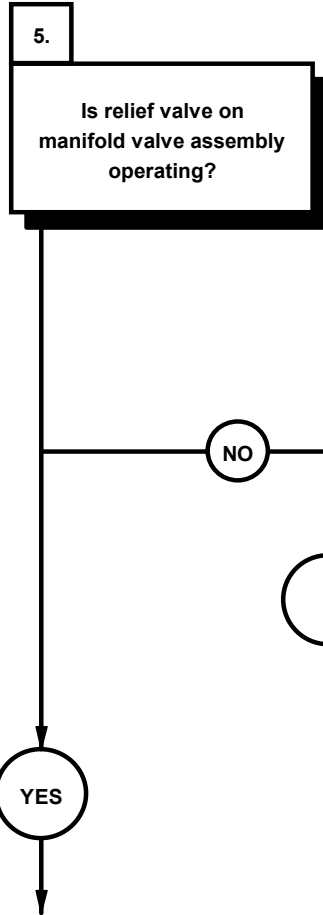

TEST OPTIONS
Relief Valve Test
REASON FOR QUESTION
A damaged relief valve may cause continual air loss and prevent proper inflation of tires for CTIS mode.



RELIEF VALVE TEST

- (1) Remove kick panel (para 16-3).
- (2) Check if relief valve poppet on manifold valve assembly is missing.
- (3) Position master power switch to on (TM 9-2320-366-10-1).
- (4) Select a mode that is lower on CTIS ECU (TM 9-2320-366-10-1).
- (5) Check if air escapes continuously from relief valve during deflation sequence.
- (6) If air escapes continuously, replace relief valve (para 12-7).
- (7) Position master power switch to off (TM 9-2320-366-10-1).

MANIFOLD VALVE ASSEMBLY

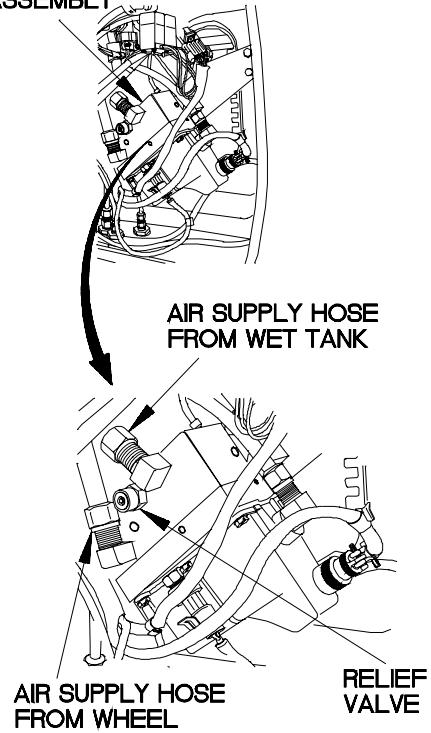

42M0104A

m1. TWO STEADY MODE LIGHTS ILLUMINATE ON CENTRAL TIRE INFLATION SYSTEM (CTIS) ECU (CONT)

KNOWN INFO
Air hoses from wet tank to manifold valve assembly OK. Air compressor and governor adjustment OK. Wheel valves venting OK. Manifold valve assembly relief valve OK.
POSSIBLE PROBLEMS
Faulty manifold valve assembly. Faulty quick release valve(s). Faulty rear axle quick release valve fittings. Faulty intermediate axle quick release valve fittings. Faulty intermediate axle tee fittings. Faulty front quick release valve fittings. Faulty front tee fittings. Faulty manifold valve assembly delivery port fittings. Faulty cab floor supply hose fittings. Faulty supply hoses from quick release valve(s) to wheel valve(s). Faulty wheel valve filters. Faulty electrical connections at CTIS ECU and manifold valve assembly. Faulty ECU.

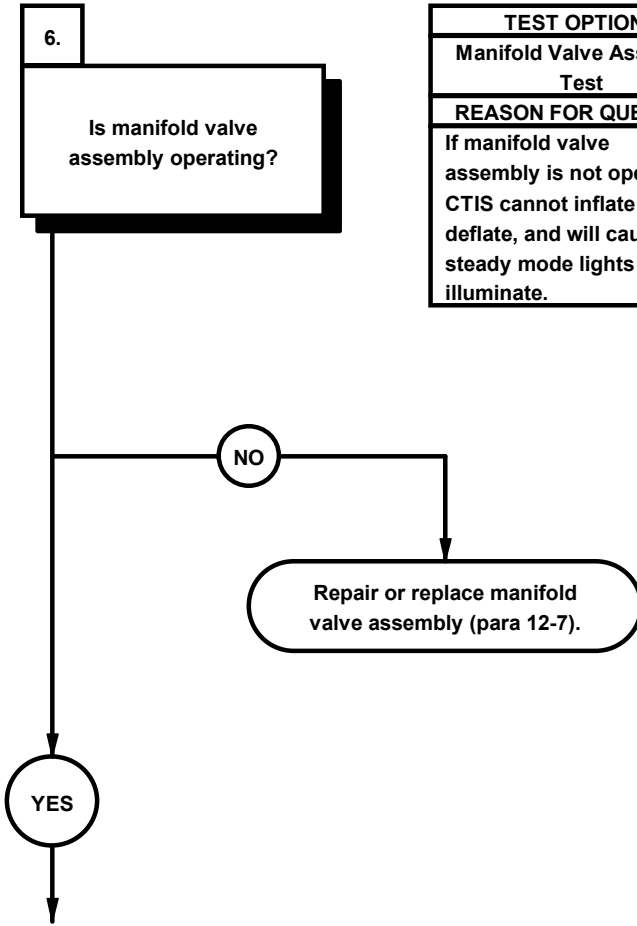

TEST OPTIONS
Manifold Valve Assembly Test
REASON FOR QUESTION
If manifold valve assembly is not operating, CTIS cannot inflate or deflate, and will cause two steady mode lights to illuminate.



NOTE

When checking manifold valve assembly, ensure air pressure in air tanks is 120 psi. Manifold valve assembly cannot be checked if air supply is not available to it.

MANIFOLD VALVE ASSEMBLY TEST

- (1) Position master power switch to on (TM 9-2320-366-10-1).
- (2) If two mode lights illuminate during deflation:
 - (a) Select a mode that is lower on CTIS ECU (TM 9-2320-366-10-1).
 - (b) Check if manifold valve assembly clicks when no air is escaping from relief valve.
 - (c) If manifold valve assembly clicks and no air escapes at relief valve, replace manifold valve assembly (para 12-7).
- (3) If two mode lights illuminate during inflation:
 - (a) Select a mode that is higher on CTIS ECU (TM 9-2320-366-10-1).
 - (b) Disconnect air hose at delivery port of manifold valve assembly.
 - (c) Check if manifold valve assembly clicks and no air escapes at delivery port.
 - (d) If no air escapes at delivery port during inflation mode, replace manifold valve assembly (para 12-7).

MANIFOLD VALVE ASSEMBLY

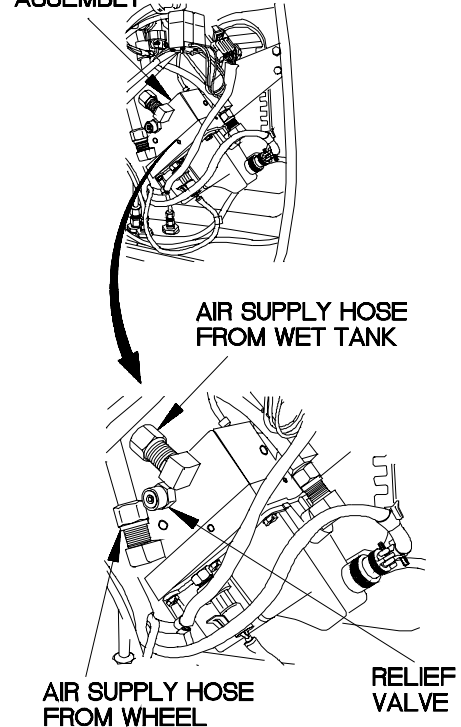

42M0105A

m1. TWO STEADY MODE LIGHTS ILLUMINATE ON CENTRAL TIRE INFLATION SYSTEM (CTIS) ECU (CONT)

KNOWN INFO
Air hoses from wet tank to manifold valve assembly OK. Air compressor and governor adjustment OK. Wheel valves venting OK. Manifold valve assembly relief valve OK. Manifold valve assembly OK.
POSSIBLE PROBLEMS
Faulty CTIS quick release valve(s). Faulty rear axle quick release valve fittings. Faulty intermediate axle quick release valve fittings. Faulty intermediate axle tee fittings. Faulty front quick release valve fittings. Faulty front tee fittings. Faulty manifold valve assembly delivery port fittings. Faulty cab floor supply hose fittings. Faulty supply hoses from quick release valve(s) to wheel valve(s). Faulty wheel valve filters. Faulty electrical connections at CTIS ECU and manifold valve assembly. Faulty ECU.

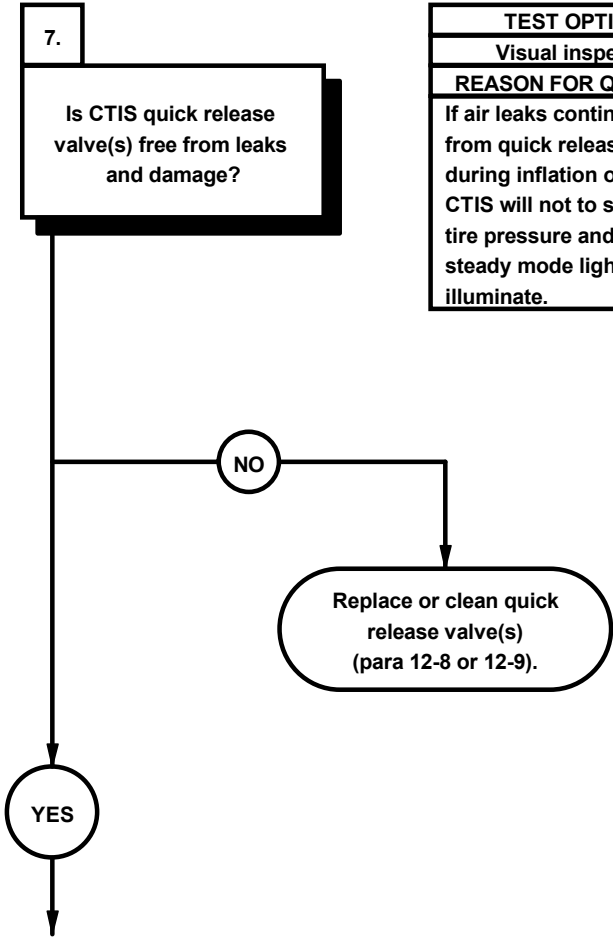

TEST OPTIONS
Visual inspection
REASON FOR QUESTION
If air leaks continuously from quick release valve(s) during inflation or deflation, CTIS will not to selected tire pressure and two steady mode lights will illuminate.



- (1) Position CTIS ECU in a mode that is higher.
- (2) Check for air escaping continuously from exhaust port of quick release valve.
- (3) If air escapes continuously from quick release valve during inflation, quick release valve diaphragm is damaged, replace quick release valve(s) (para 12-9).

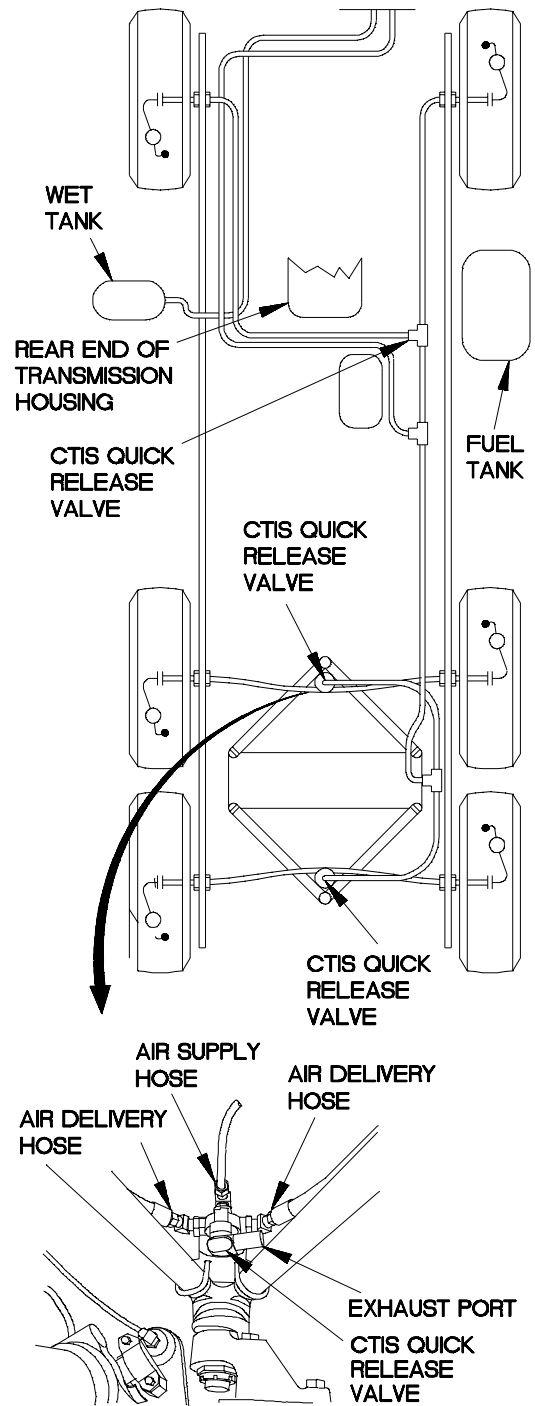

4EM0106A

m1. TWO STEADY MODE LIGHTS ILLUMINATE ON CENTRAL TIRE INFLATION SYSTEM (CTIS) ECU (CONT)

KNOWN INFO
Air hoses from wet tank to manifold valve assembly OK.
Air compressor and governor adjustment OK.
Wheel valves venting OK.
Manifold valve assembly relief valve OK.
Manifold valve assembly OK.
Quick release valves OK.
POSSIBLE PROBLEMS
Faulty rear axle quick release valve fittings.
Faulty intermediate axle quick release valve fittings.
Faulty intermediate axle tee fittings.
Faulty front quick release valve fittings.
Faulty front tee fittings.
Faulty manifold valve assembly delivery port fittings.
Faulty cab floor supply hose fittings.
Faulty supply hoses from quick release valve(s) to wheel valve(s).
Faulty wheel valve filters.
Faulty electrical connections at CTIS ECU and manifold valve assembly.
Faulty ECU.

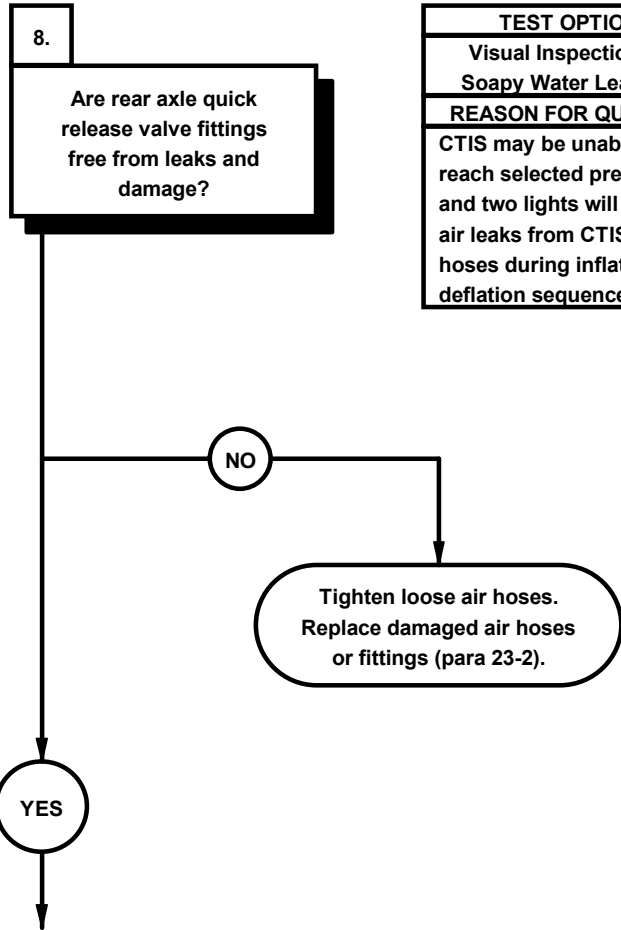

TEST OPTIONS
Visual Inspection and Soapy Water Leak Test
REASON FOR QUESTION
CTIS may be unable to reach selected pressure and two lights will flash if air leaks from CTIS air hoses during inflation/deflation sequences.



- (1) Select an inflation mode at CTIS ECU (TM 9-2320-366-10-1).
- (2) If obvious air escape is heard, tighten loose air hoses or replace damaged air hoses and/or fittings (para 23-2).
- (3) If no obvious air escape is heard, proceed to Soapy Water Leak Test.

SOAPY WATER LEAK TEST

- (1) Apply soapy water solution to quick release valve fittings at rear axle.
- (2) Check for air bubbles indicating leaks.

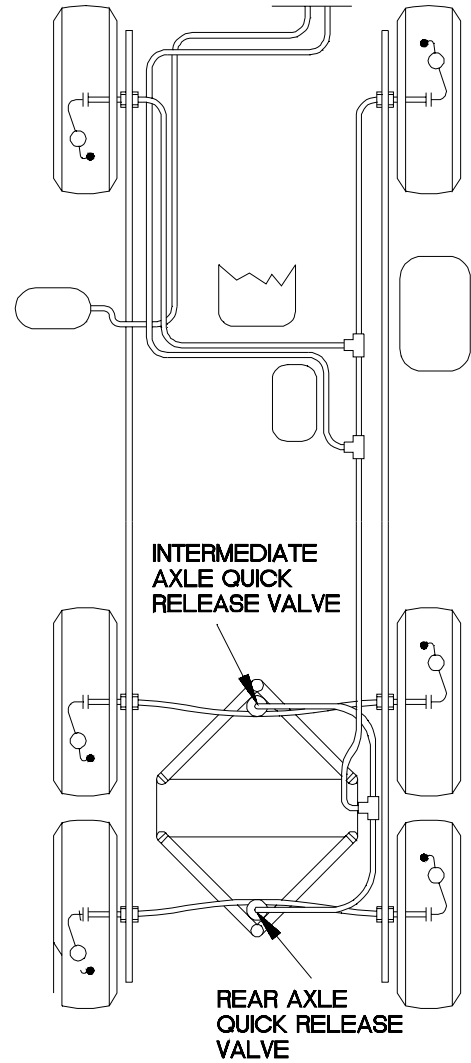

42M0107A

m1. TWO STEADY MODE LIGHTS ILLUMINATE ON CENTRAL TIRE INFLATION SYSTEM (CTIS) ECU (CONT)

KNOWN INFO
Air hoses from wet tank to manifold valve assembly OK. Air compressor and governor adjustment OK. Wheel valves venting OK. Manifold valve assembly relief valve OK. Manifold valve assembly OK. Quick release valves OK. Rear axle quick release valve fittings OK.
POSSIBLE PROBLEMS
Faulty intermediate axle quick release valve fittings. Faulty intermediate axle tee fittings. Faulty front quick release valve fittings. Faulty front tee fittings. Faulty manifold valve assembly delivery port fittings. Faulty cab floor supply hose fittings. Faulty supply hoses from quick release valve(s) to wheel valve(s). Faulty wheel valve filters. Faulty electrical connections at CTIS ECU and manifold valve assembly. Faulty ECU.

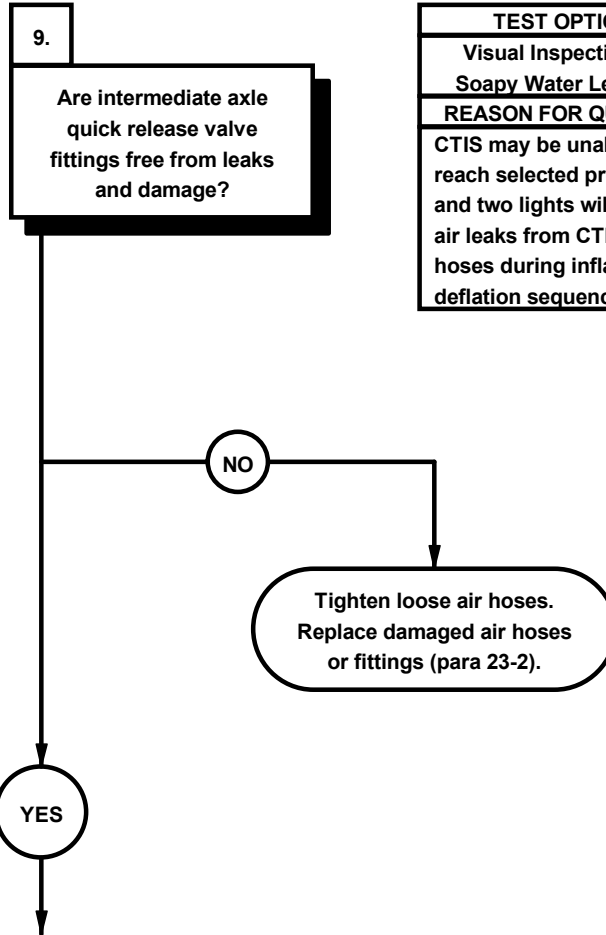

TEST OPTIONS
Visual Inspection and Soapy Water Leak Test
REASON FOR QUESTION
CTIS may be unable to reach selected pressure and two lights will flash if air leaks from CTIS air hoses during inflation/deflation sequences.

- (1) Select an inflation mode at CTIS ECU (TM 9-2320-366-10-1).
- (2) If obvious air escape is heard. Tighten loose air hoses and/or replace damaged air hoses and/or fittings (para 23-2).
- (3) If no obvious air escape is heard, proceed to Soapy Water Leak Test.

SOAPY WATER LEAK TEST

- (1) Apply soapy water solution to quick release valve fittings at intermediate axle.
- (2) Check for air bubbles indicating leaks.

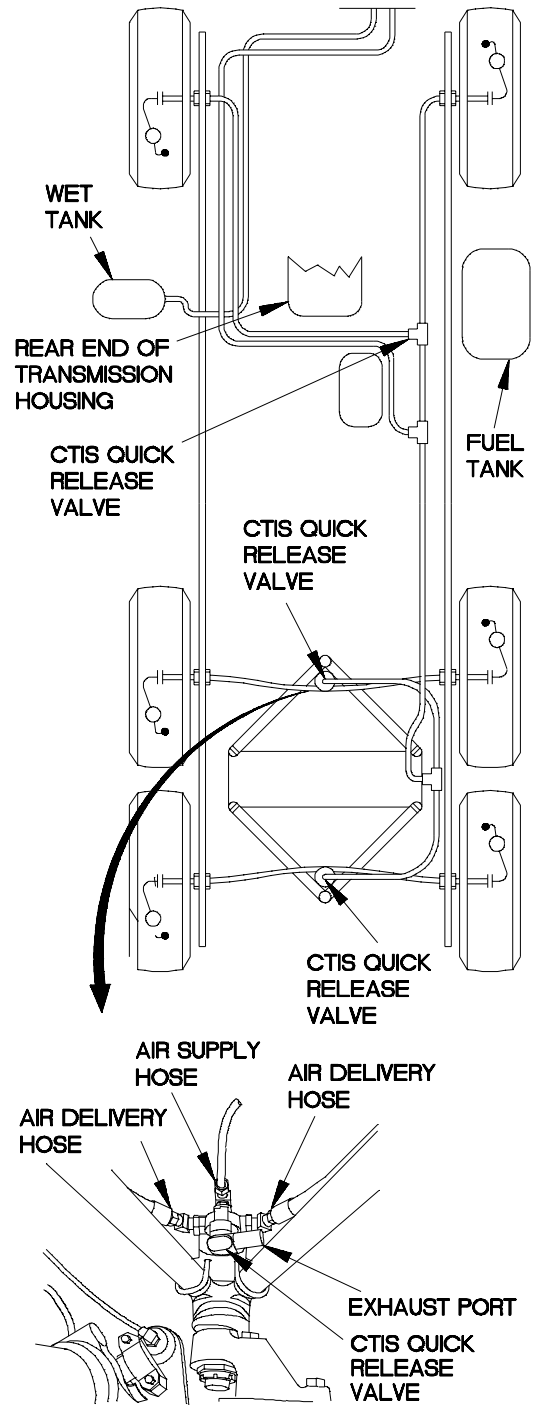

42M0108A

m1. TWO STEADY MODE LIGHTS ILLUMINATE ON CENTRAL TIRE INFLATION SYSTEM (CTIS) ECU (CONT)

KNOWN INFO
Air hoses from wet tank to manifold valve assembly OK. Air compressor and governor adjustment OK. Wheel valves venting OK. Manifold valve assembly relief valve OK. Manifold valve assembly OK. Quick release valves OK. Rear axle quick release valve fittings OK. Intermediate axle quick release valve fittings OK.
POSSIBLE PROBLEMS
Faulty intermediate axle tee fittings. Faulty front quick release valve fittings. Faulty front tee fittings. Faulty manifold valve assembly delivery port fittings. Faulty cab floor supply hose fittings. Faulty supply hoses from quick release valve(s) to wheel valve(s). Faulty wheel valve filters. Faulty electrical connections at CTIS ECU and manifold valve assembly. Faulty ECU.

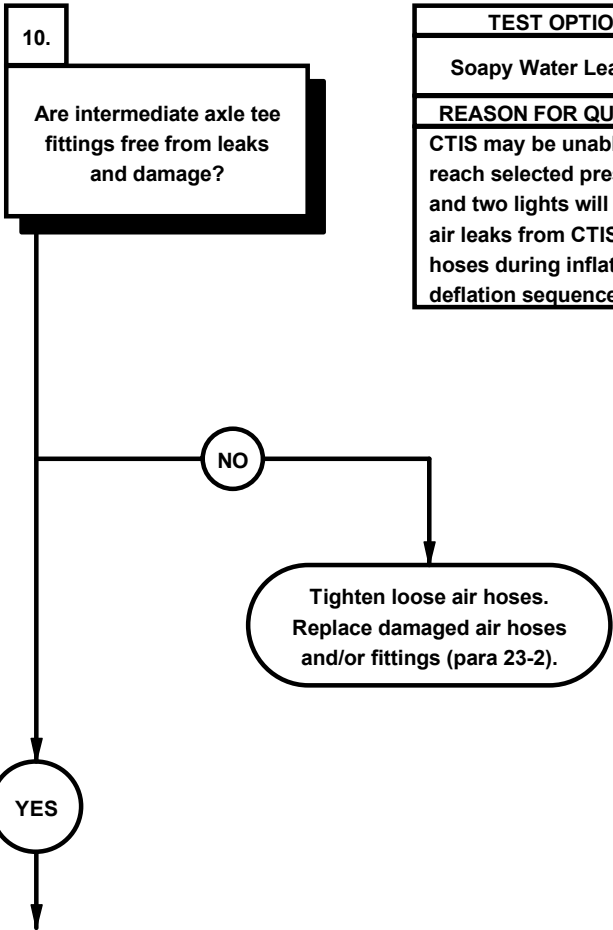

TEST OPTIONS
Soapy Water Leak Test
REASON FOR QUESTION
CTIS may be unable to reach selected pressure and two lights will flash if air leaks from CTIS air hoses during inflation/deflation sequences.



SOAPY WATER LEAK TEST	
(1)	Apply soapy water solution to tee fittings at intermediate axle.
(2)	Check for air bubbles indicating leaks.

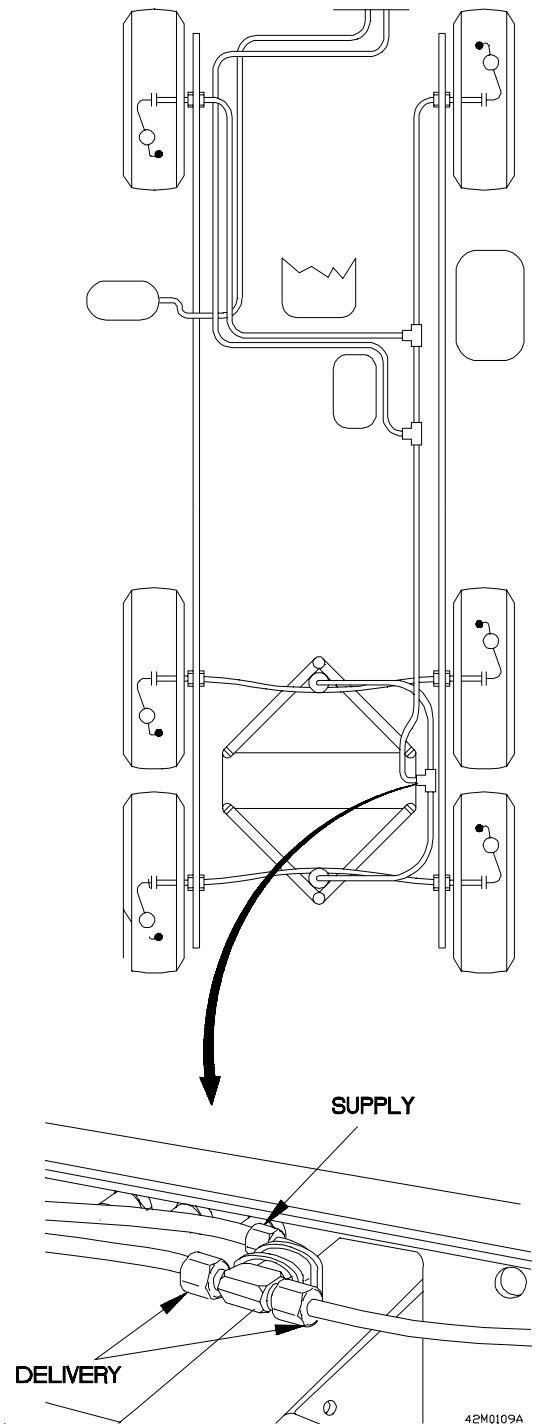

m1. TWO STEADY MODE LIGHTS ILLUMINATE ON CENTRAL TIRE INFLATION SYSTEM (CTIS) ECU (CONT)

KNOWN INFO
Air hoses from wet tank to manifold valve assembly OK. Air compressor and governor adjustment OK. Wheel valves venting OK. Manifold valve assembly relief valve OK. Manifold valve assembly OK. Quick release valves OK. Rear axle quick release valve fittings OK. Intermediate axle quick release valve fittings OK. Intermediate axle tee fittings OK.
POSSIBLE PROBLEMS
Faulty front quick release valve fittings. Faulty front tee fittings. Faulty manifold valve assembly delivery port fittings. Faulty cab floor supply hose fittings. Faulty supply hoses from quick release valve(s) to wheel valve(s). Faulty wheel valve filters. Faulty electrical connections at CTIS ECU and manifold valve assembly. Faulty ECU.

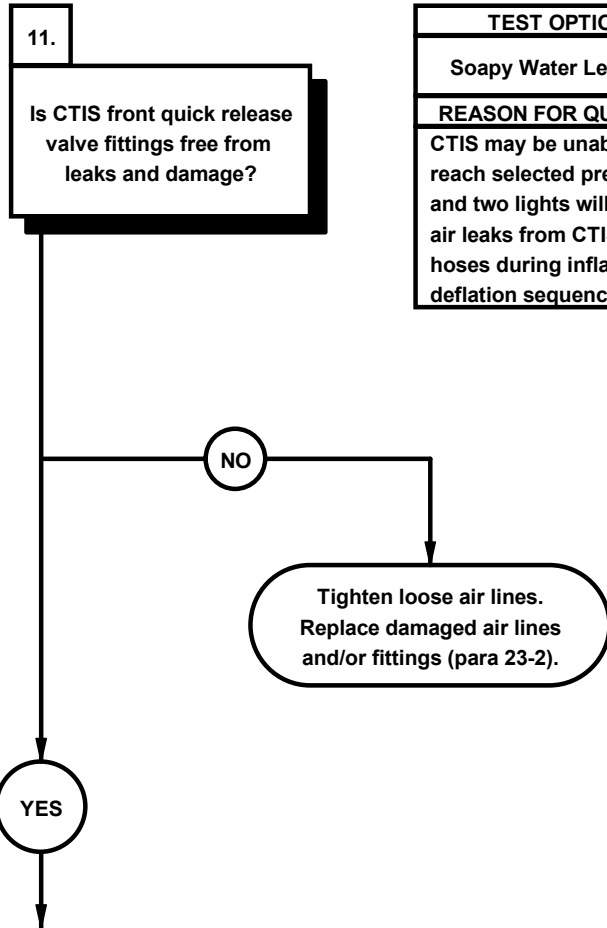

TEST OPTIONS
Soapy Water Leak Test
REASON FOR QUESTION
CTIS may be unable to reach selected pressure and two lights will flash if air leaks from CTIS air hoses during inflation/deflation sequences.



SOAPY WATER LEAK TEST	
(1)	Apply soapy water solution to front quick release valve fittings.
(2)	Check for air bubbles indicating leaks.

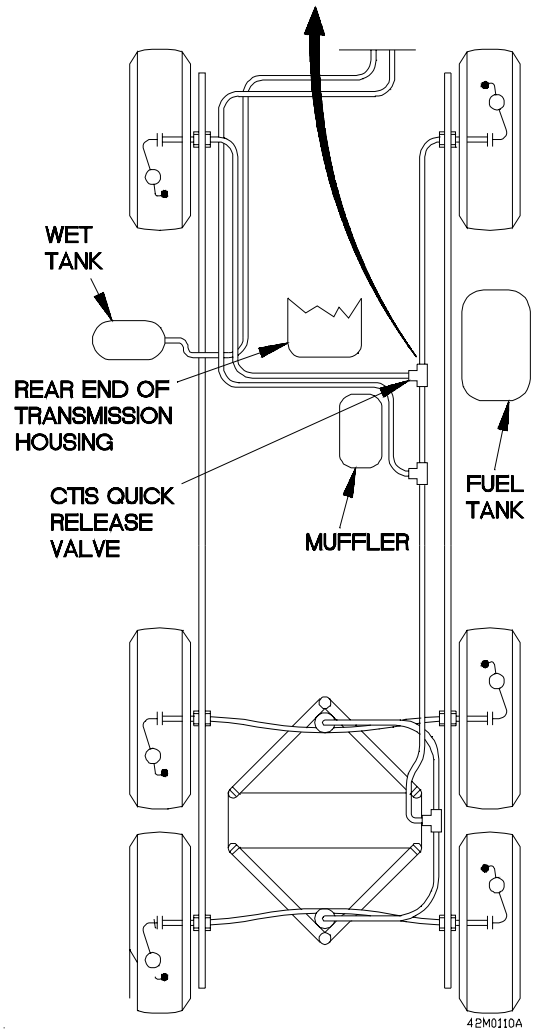
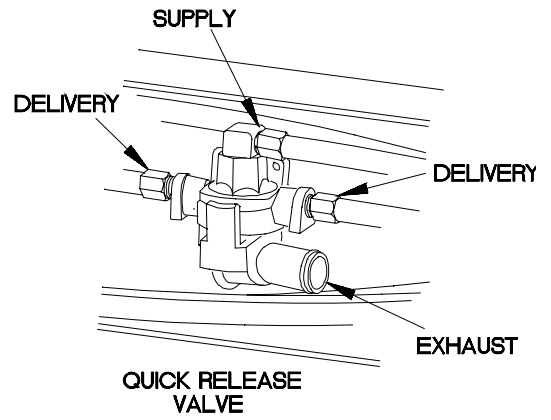

42M0110A

m1. TWO STEADY MODE LIGHTS ILLUMINATE ON CENTRAL TIRE INFLATION SYSTEM (CTIS) ECU (CONT)

KNOWN INFO
Air hoses from wet tank to manifold valve assembly OK. Air compressor and governor adjustment OK. Wheel valves venting OK. Manifold valve assembly relief valve OK. Manifold valve assembly OK. Quick release valves OK. Rear axle quick release valve fittings OK. Intermediate axle quick release valve fittings OK. Intermediate axle tee fittings OK. Front quick release valve fittings OK.
POSSIBLE PROBLEMS
Faulty front tee fittings. Faulty manifold valve assembly delivery port fittings. Faulty cab floor supply hose fittings. Faulty supply hoses from quick release valve(s) to wheel valve(s). Faulty wheel valve filters. Faulty electrical connections at CTIS ECU and manifold valve assembly. Faulty ECU.

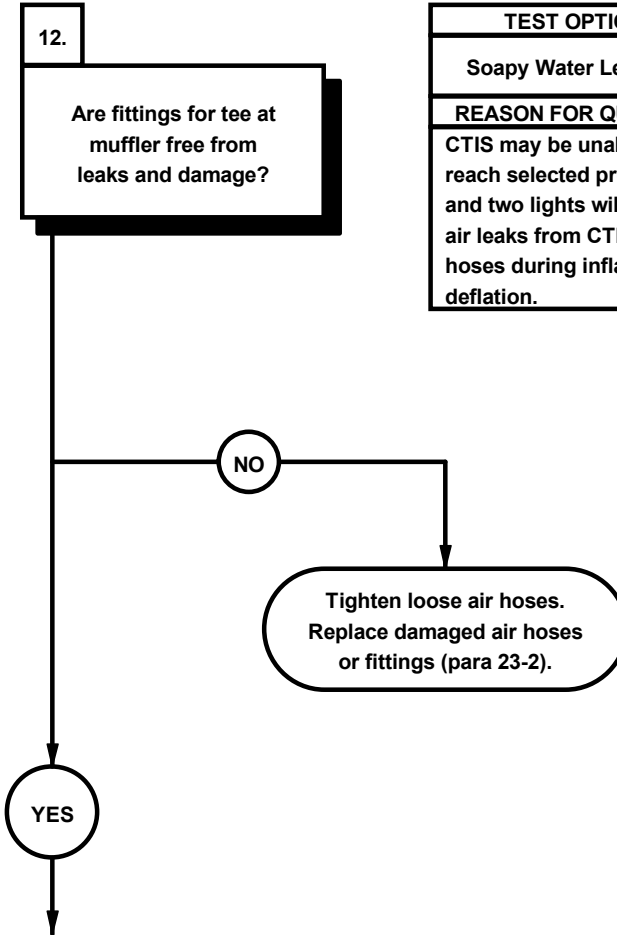

TEST OPTIONS
Soapy Water Leak Test
REASON FOR QUESTION
CTIS may be unable to reach selected pressure and two lights will flash if air leaks from CTIS air hoses during inflation/deflation.



SOAPY WATER LEAK TEST	
(1)	Apply soapy water solution to fittings at tee above muffler.
(2)	Check for air bubbles indicating leaks.

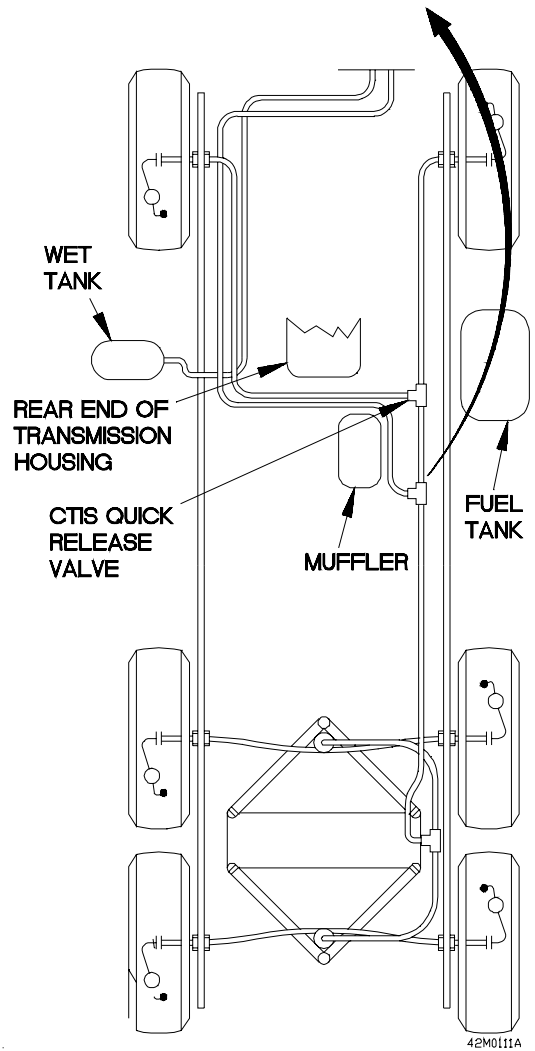
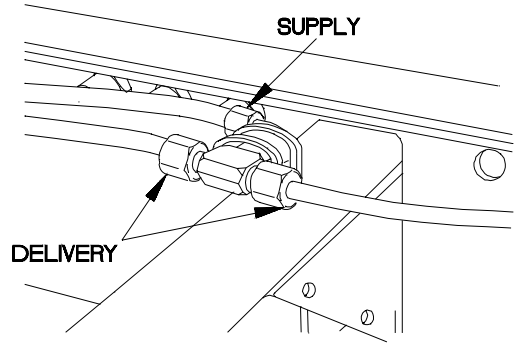

m1. TWO STEADY MODE LIGHTS ILLUMINATE ON CENTRAL TIRE INFLATION SYSTEM (CTIS) ECU (CONT)

KNOWN INFO
Air hoses from wet tank to manifold valve assembly OK. Air compressor and governor adjustment OK. Wheel valves venting OK. Manifold valve assembly relief valve OK. Manifold valve assembly OK. Quick release valves OK. Rear axle quick release valve fittings OK. Intermediate axle quick release valve fittings OK. Intermediate axle tee fittings OK. Front quick release valve fittings OK. Front tee fittings OK.
POSSIBLE PROBLEMS
Faulty manifold valve assembly delivery port fittings. Faulty cab floor supply hose fittings. Faulty supply hoses from quick release valve(s) to wheel valve(s). Faulty wheel valve filters. Faulty electrical connections at CTIS ECU and manifold valve assembly. Faulty ECU.

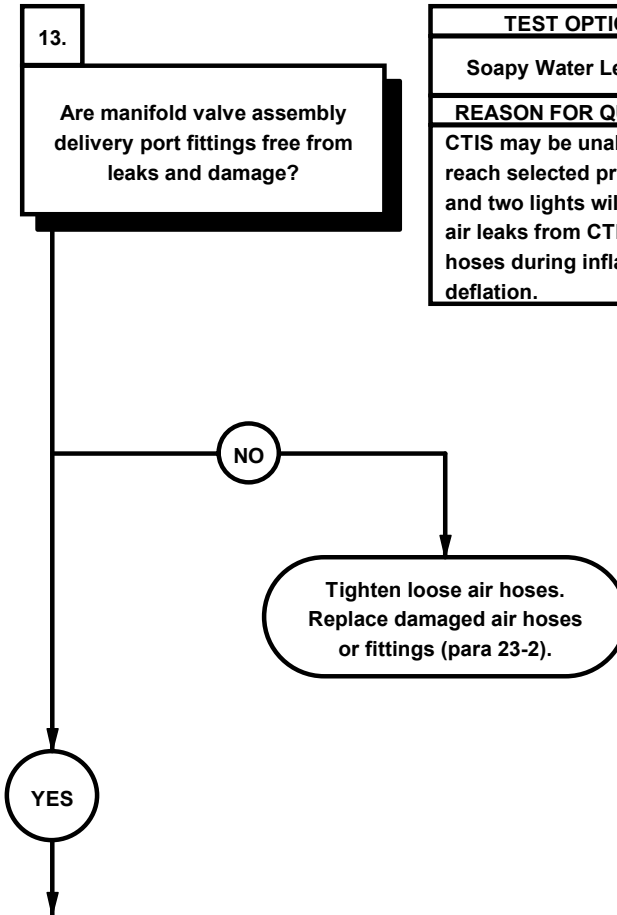

TEST OPTIONS
Soapy Water Leak Test
REASON FOR QUESTION
CTIS may be unable to reach selected pressure and two lights will flash if air leaks from CTIS air hoses during inflation/deflation.



SOAPY WATER LEAK TEST
(1) Apply soapy water solution to manifold valve assembly delivery port fittings.
(2) Check for air bubbles indicating leaks.

MANIFOLD VALVE ASSEMBLY

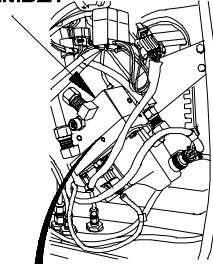

DELIVERY PORT

MANIFOLD VALVE ASSEMBLY

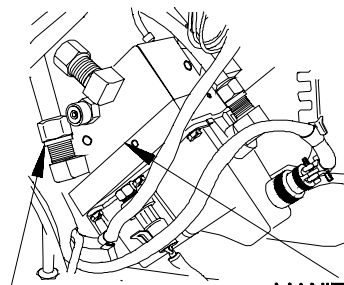

42M0112A

m1. TWO STEADY MODE LIGHTS ILLUMINATE ON CENTRAL TIRE INFLATION SYSTEM (CTIS) ECU (CONT)

KNOWN INFO
Air hoses from wet tank to manifold valve assembly OK. Air compressor and governor adjustment OK. Wheel valves venting OK. Manifold valve assembly relief valve OK. Manifold valve assembly OK. Quick release valves OK. Rear axle quick release valve fittings OK. Intermediate axle quick release valve fittings OK. Intermediate axle tee fittings OK. Front quick release valve fittings OK. Front tee fittings OK. Manifold valve assembly delivery port fittings OK.
POSSIBLE PROBLEMS
Faulty cab floor supply hose fittings. Faulty supply hoses from quick release valve(s) to wheel valve(s). Faulty wheel valve filters. Faulty electrical connections at CTIS ECU and manifold valve assembly. Faulty ECU.

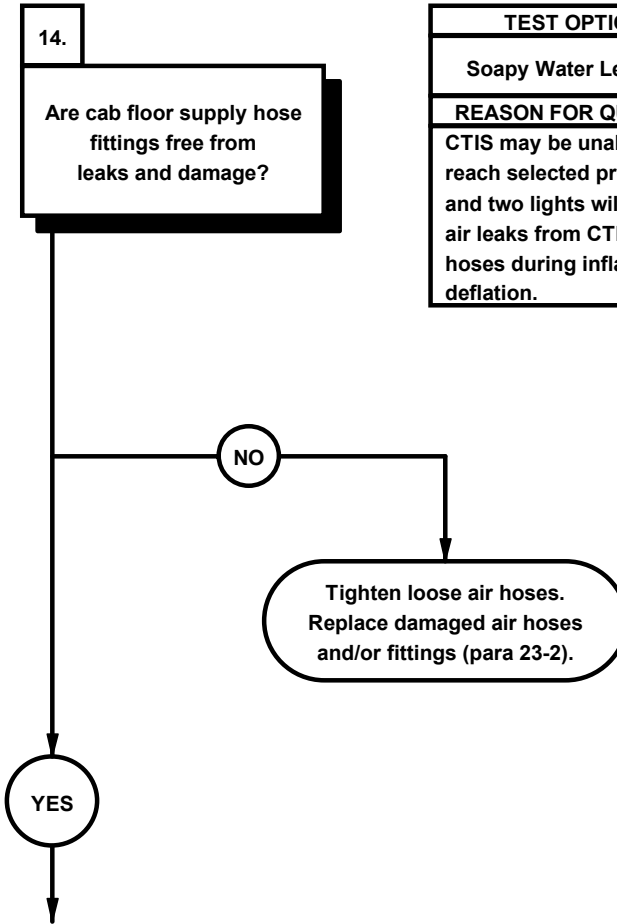

TEST OPTIONS
Soapy Water Leak Test
REASON FOR QUESTION
CTIS may be unable to reach selected pressure and two lights will flash if air leaks from CTIS air hoses during inflation/deflation.



SOAPY WATER LEAK TEST

- (1) Remove two screws and washers from front grille.
- (2) Remove screw and washer from front grille.
- (3) Remove front grille from cab.
- (4) Apply soapy water solution to cab floor supply hose fittings.
- (5) Check for air bubbles indicating leaks.
- (6) Position front grille on cab with washer and screw.
- (7) Position two washers and screws in front grille.
- (8) Tighten screw to 48-60 lb-in. (5-7 N·m).
- (9) Tighten two screws to 24 lb-in. (3 N·m).

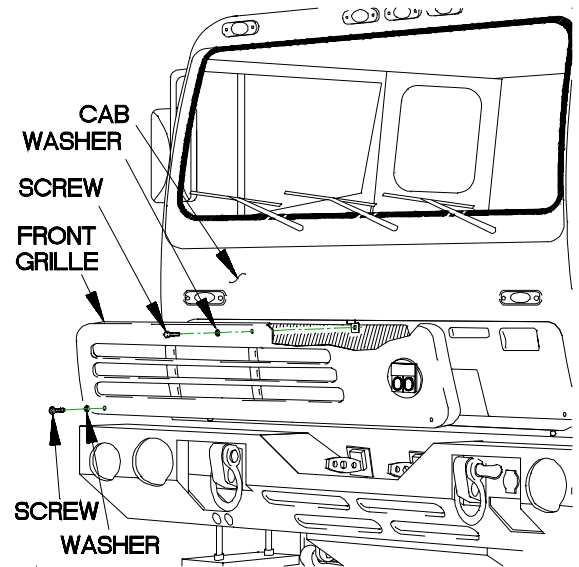

AIR DELIVERY HOSE TO WHEELS
 AIR SUPPLY HOSE TO MANIFOLD VALVE ASSEMBLY

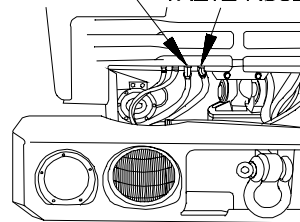

X2M0113A

m1. TWO STEADY MODE LIGHTS ILLUMINATE ON CENTRAL TIRE INFLATION SYSTEM (CTIS) ECU (CONT)

KNOWN INFO
Air hoses from wet tank to manifold valve assembly OK. Air compressor and governor adjustment OK. Wheel valves venting OK. Manifold valve assembly relief valve OK. Manifold valve assembly OK. Quick release valves OK. Rear axle quick release valve fittings OK. Intermediate axle quick release valve fittings OK. Intermediate axle tee fittings OK. Front quick release valve fittings OK. Front tee fittings OK. Manifold valve assembly delivery port fittings OK. Cab floor supply line fittings OK.
POSSIBLE PROBLEMS
Faulty supply hoses from quick release valve(s) to wheel valve(s). Faulty wheel valve filters. Faulty electrical connections at CTIS ECU and manifold valve assembly. Faulty ECU.

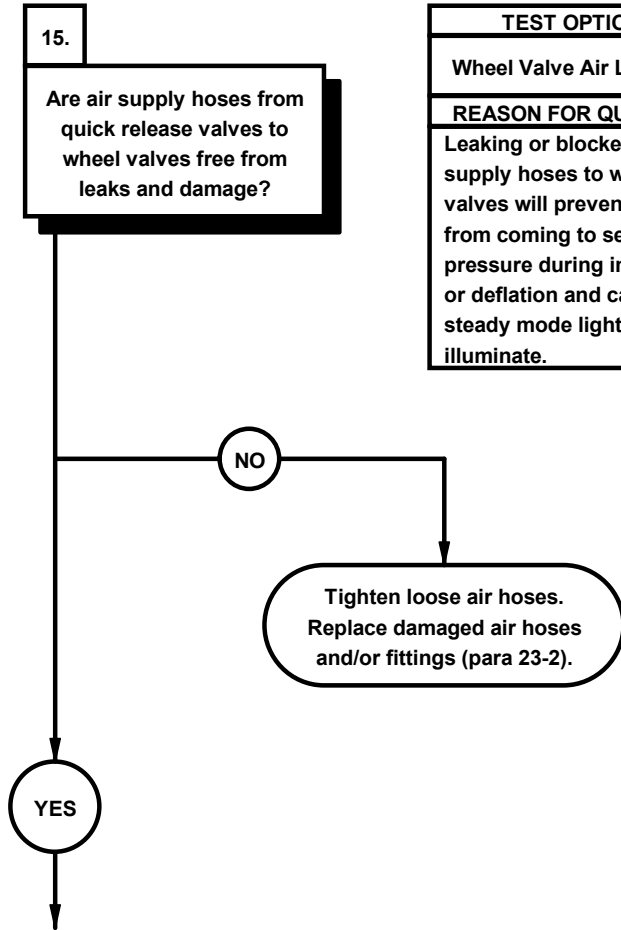

TEST OPTIONS
Wheel Valve Air Line Test
REASON FOR QUESTION
Leaking or blocked air supply hoses to wheel valves will prevent CTIS from coming to selected pressure during inflation or deflation and cause two steady mode lights to illuminate.



WHEEL VALVE AIR LINE TEST

- (1) Check tire pressures after a deflation or inflation sequence. If one or more tires are at a different pressure than the rest, air hose to affected wheel(s) may be faulty.
- (2) Disconnect supply air hose at banjo fitting on affected wheel(s).
- (3) Select an inflation sequence at CTIS ECU (TM 9-2320-366-10-1).
- (4) Check if air escapes at wheel during inflation.
- (5) If air does not escape, locate leak or blockage by tracing hose between quick release valve and affected wheel(s) (refer to pneumatic schematic).

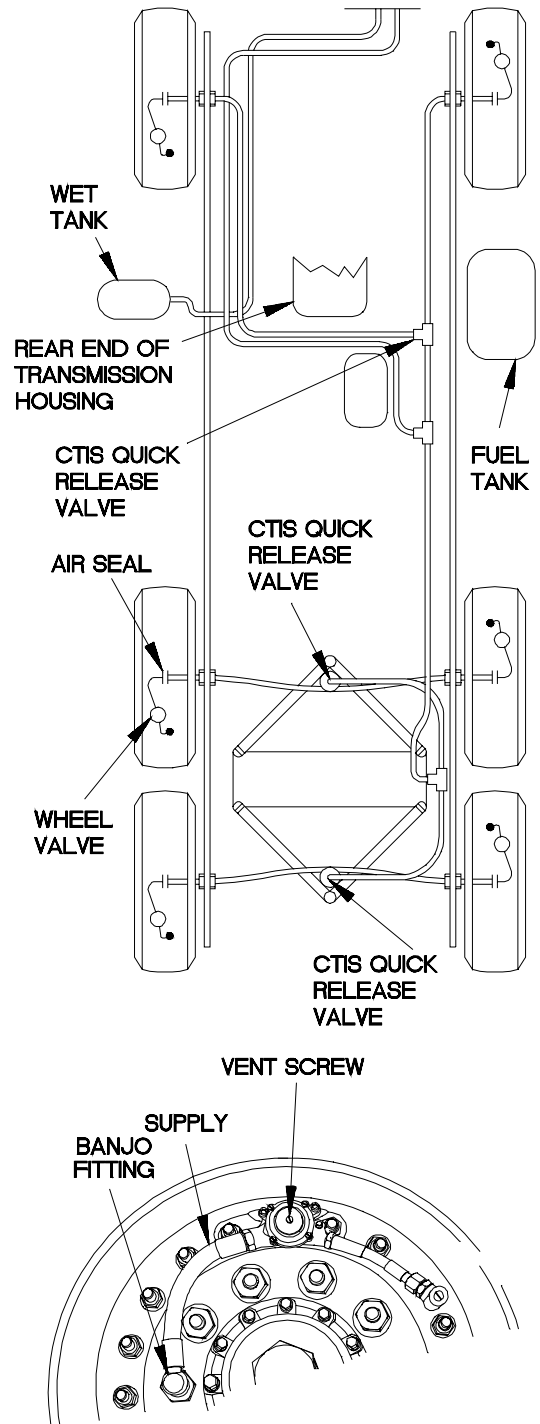

42M0114A

m1. TWO STEADY MODE LIGHTS ILLUMINATE ON CENTRAL TIRE INFLATION SYSTEM (CTIS) ECU (CONT)

KNOWN INFO
Air hoses from wet tank to manifold valve assembly OK. Air compressor and governor adjustment OK. Wheel valves venting OK. Manifold valve assembly relief valve OK. Manifold valve assembly OK. Quick release valves OK. Rear axle quick release valve fittings OK. Intermediate axle quick release valve fittings OK. Intermediate axle tee fittings OK. Front quick release valve fittings OK. Front tee fittings OK. Manifold valve assembly delivery port fittings OK. Cab floor supply hose fittings OK. Supply hoses from quick release valve to wheel valves OK.
POSSIBLE PROBLEMS
Faulty wheel valve filters. Faulty electrical connections at CTIS ECU and manifold valve assembly. Faulty ECU.

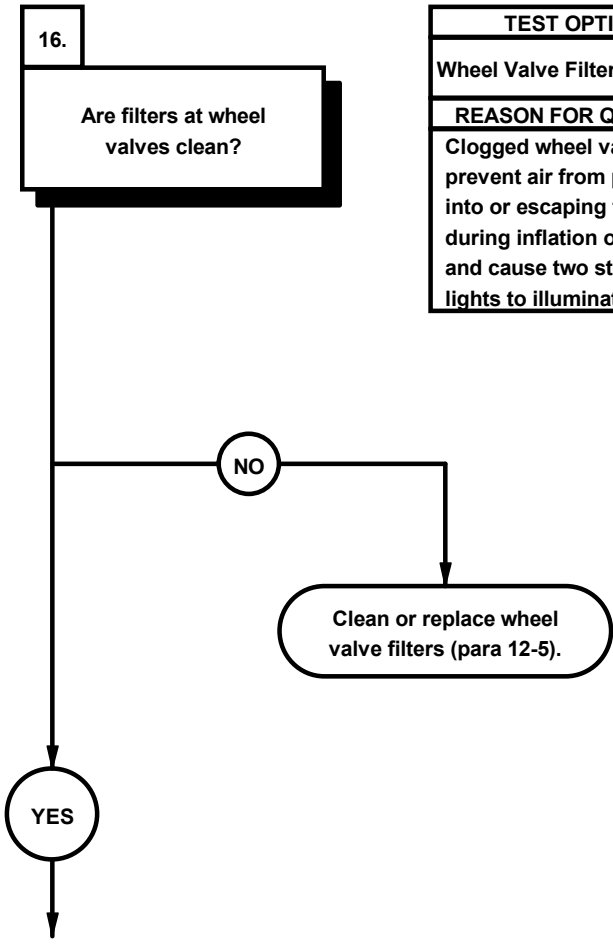

TEST OPTIONS
Wheel Valve Filter Inspection
REASON FOR QUESTION
Clogged wheel valve filters prevent air from passing into or escaping from tires during inflation or deflation and cause two steady mode lights to illuminate.



WHEEL VALVE FILTER INSPECTION

- (1) Jack up axle at affected wheel and support with trestles.
- (2) Remove two screws from wheel valve.
- (3) Remove wheel valve and unscrew from delivery hose.
- (4) Unscrew wheel valve filter from wheel valve.
- (5) Check if filter is clean and free from obstruction.
- (6) If filter is plugged with dirt, clean or replace wheel valve filters (para 12-5).
- (7) Install wheel valve on delivery hose.
- (8) Install wheel valve with two screws.
- (9) Install supply air line on banjo fitting.

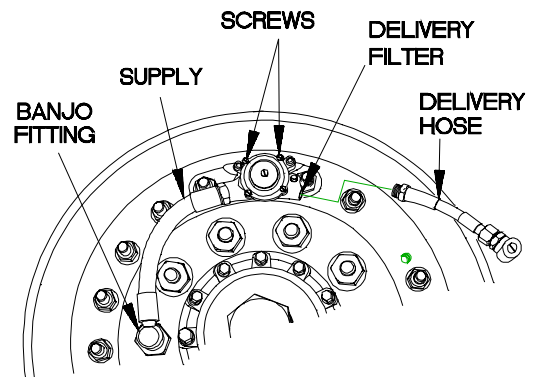
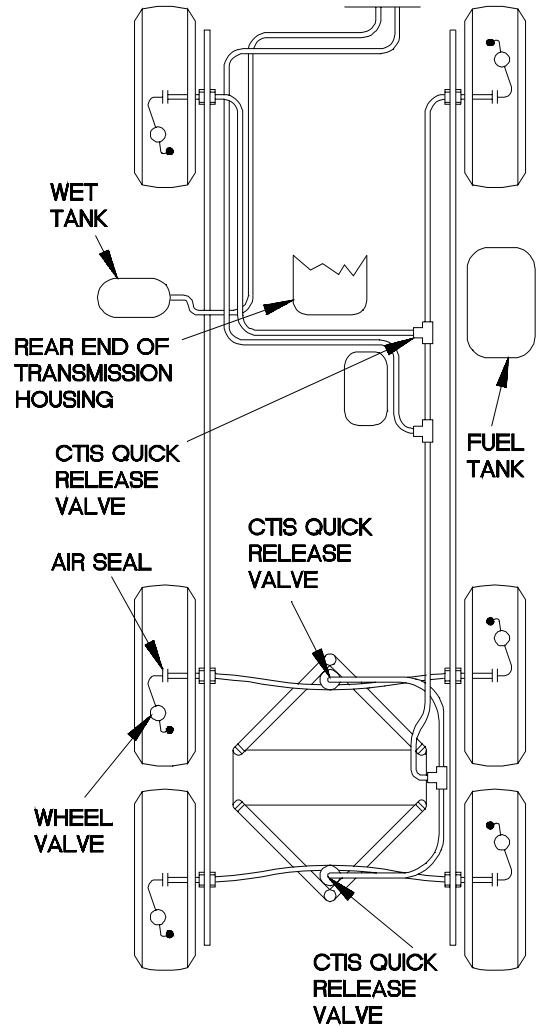

42M0115A

m1. TWO STEADY MODE LIGHTS ILLUMINATE ON CENTRAL TIRE INFLATION SYSTEM (CTIS) ECU (CONT)

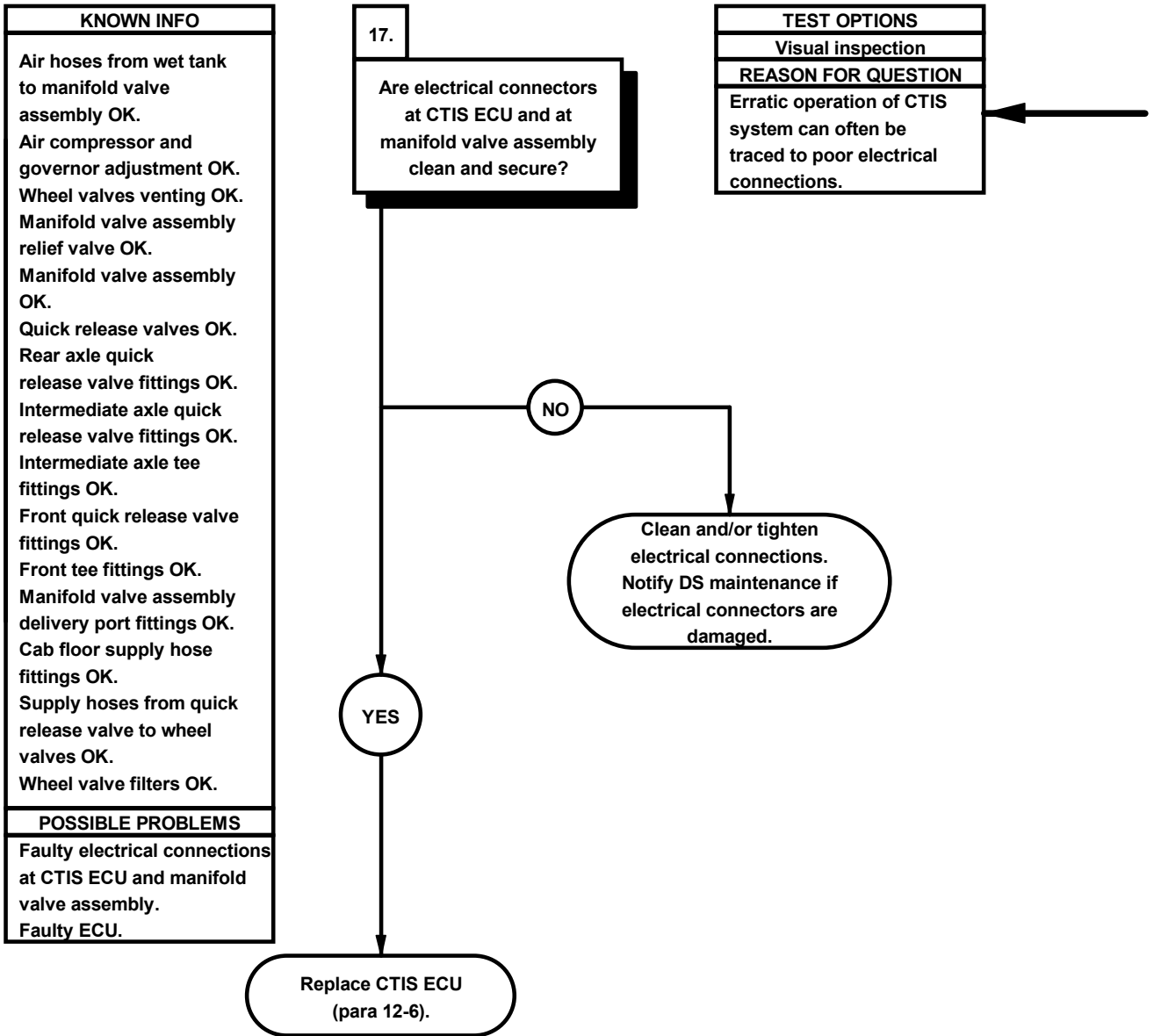

- (1) Disconnect connectors P110 at CTIS ECU, P112 at manifold valve assembly solenoid, and P113 at manifold valve assembly pressure transducer.
- (2) Check if connectors are clean and pins are undamaged.
- (3) Connect and tighten connectors P113, P112, and P110.
- (4) Install kick panel (para 16-3).

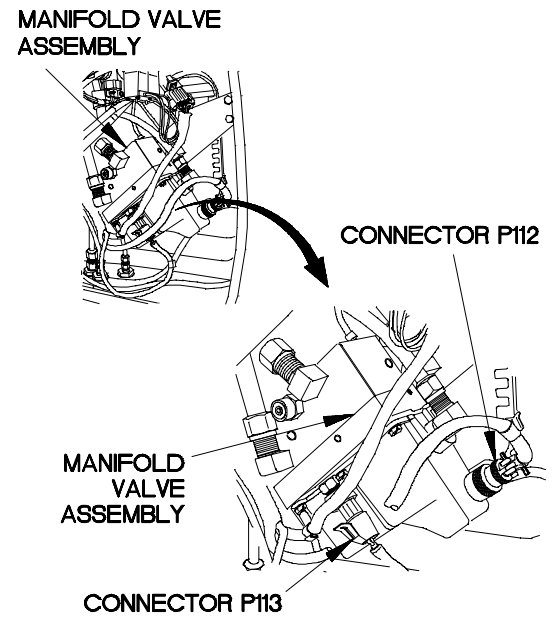
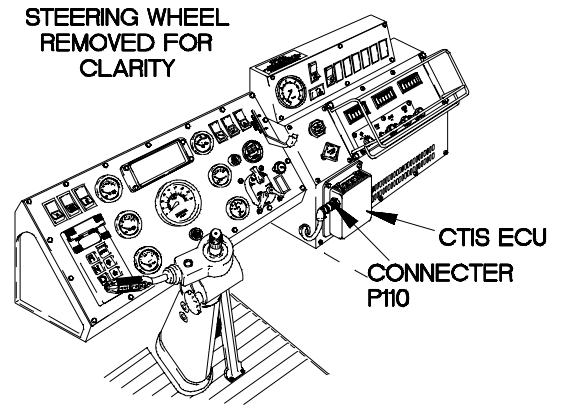

4EM0116A

m2. FOUR CENTRAL TIRE INFLATION SYSTEM (CTIS) ECU INDICATOR LIGHTS FLASHING

INITIAL SETUP

Equipment Conditions

- Engine running (TM 9-2320-366-10-1).
- Parking brake on (TM 9-2320-366-10-1).
- Wheels chocked (TM 9-2320-366-10-1).

Tools and Special Tools

- Tool Kit, Genl Mech (Item 46, Appendix C)
- Goggles, Industrial (Item 15, Appendix C)
- Gage, Tire Pressure (Item 11, Appendix C)
- Pan, Wash (Item 25, Appendix C)
- Wrench, Torque, 0-200 lb-in. (Item 59, Appendix C)

Materials/Parts

- Soap, Laundry (Item 63, Appendix D)

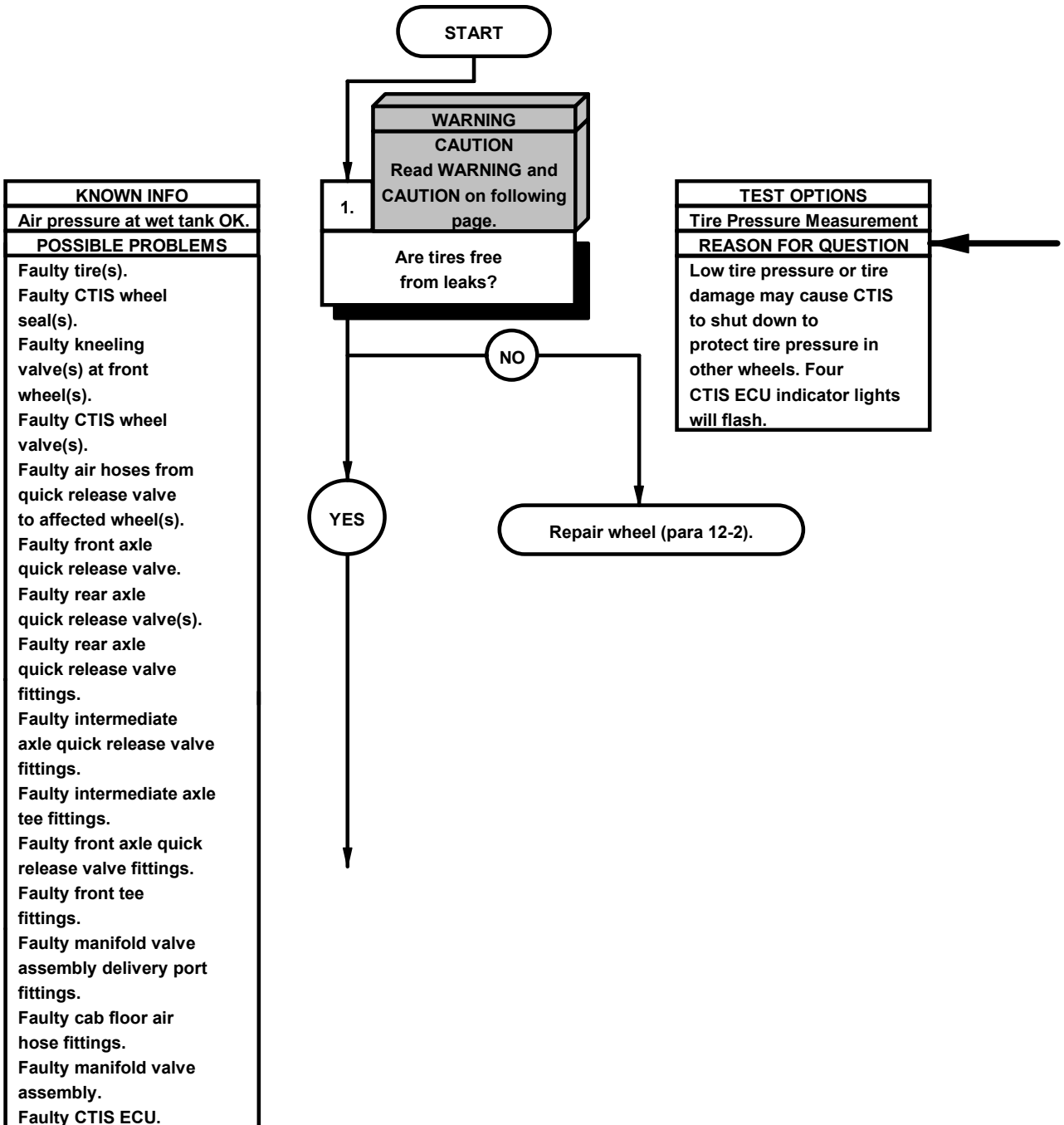

WARNING

Wear appropriate eye protection when working under vehicle and around CTIS due to the possibility of falling or blown debris. Failure to comply may result in injury to personnel.

CAUTION

When RUN FLAT has been selected to perform a troubleshooting step, be sure to press RUN FLAT again when step is completed to terminate CTIS operation and prevent excessive air loss.

NOTE

Four mode lights flashing indicate CTIS has shut off due to uneven tire pressure (one tire 50 percent less than other pressures will do it), tire damage, or major leak. Operator can continue CTIS operation by pressing RUN FLAT on CTIS ECU. When RUN FLAT has been selected CTIS ECU checks pressures at 15 second intervals.

TIRE PRESSURE MEASUREMENT

- (1) Measure and record the tire pressure of each tire (TM 9-2320-366-10-1).
- (2) If any tire pressure is lower than the rest, visually inspect tire for damage.
- (3) Apply soapy water solution to tire bead.
- (4) Observe tire for bubbles indicating leaks.

TIRE BEAD

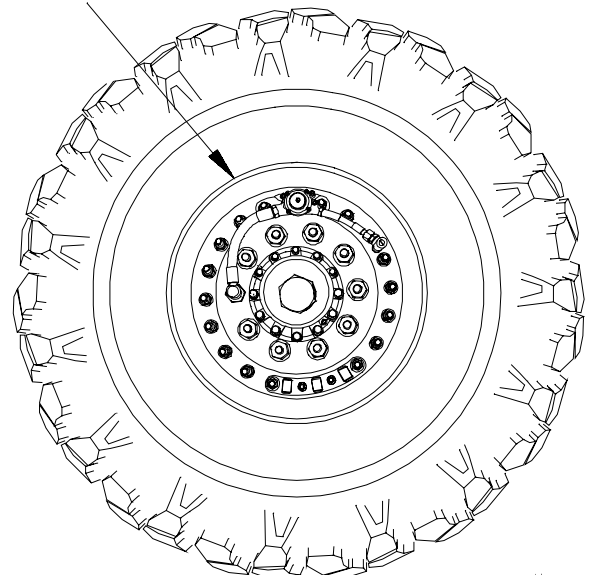

X2M0201A

m2. FOUR CENTRAL TIRE INFLATION SYSTEM (CTIS) ECU INDICATOR LIGHTS FLASHING (CONT)

KNOWN INFO
Air pressure at wet tank OK. Tires OK.
POSSIBLE PROBLEMS
Faulty CTIS wheel seal(s). Faulty kneeling valve(s) at front wheel(s). Faulty CTIS wheel valve(s). Faulty air hoses from quick release valve to affected wheel(s). Faulty front axle quick release valve. Faulty rear axle quick release valve(s). Faulty rear axle quick release valve fittings. Faulty intermediate axle quick release valve fittings. Faulty intermediate axle tee fittings. Faulty front axle quick release valve fittings. Faulty front tee fittings. Faulty manifold valve assembly delivery port fittings. Faulty cab floor air hose fittings. Faulty manifold valve assembly. Faulty CTIS ECU.

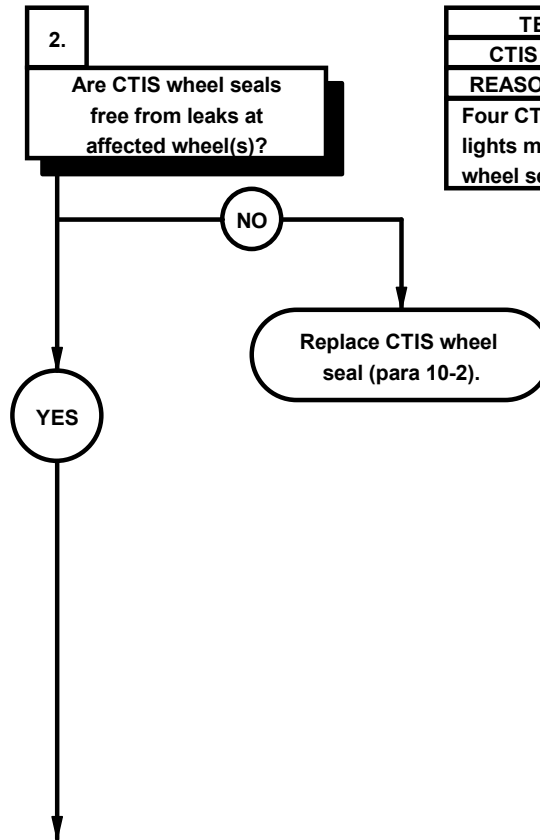

TEST OPTIONS
CTIS Wheel Seal Test
REASON FOR QUESTION
Four CTIS ECU indicator lights may flash if CTIS wheel seal is damaged.



CTIS WHEEL SEAL TEST

- (1) Check axle hubs for presence of oil leaks that indicate a damaged CTIS wheel seal.
- (2) Ensure wheel is at rest with hub plug at top of hub.
- (3) Remove hub oil plug.
- (4) Select RUN FLAT at CTIS ECU (TM 9-2320-366-10-1).
- (5) Determine if air is escaping from hub. If air escapes, replace CTIS wheel seal (para 10-2).
- (6) Install hub oil plug on wheel hub.

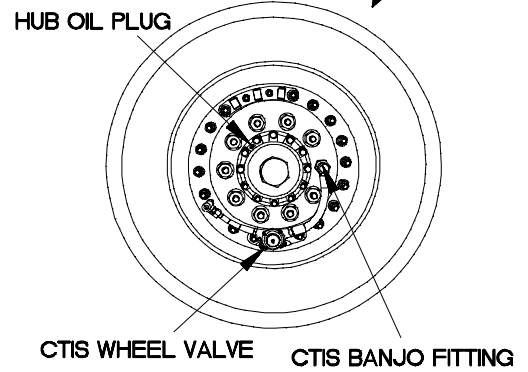
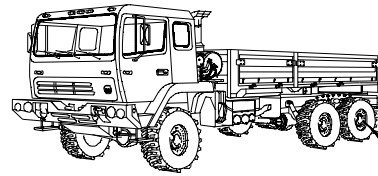

STEERING WHEEL
REMOVED FOR
CLARITY

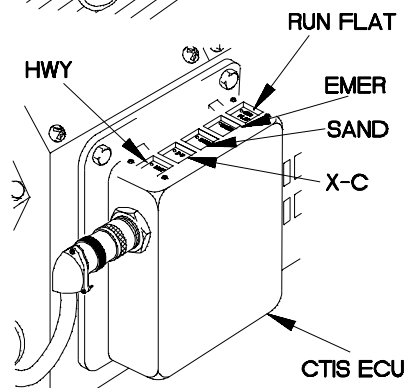
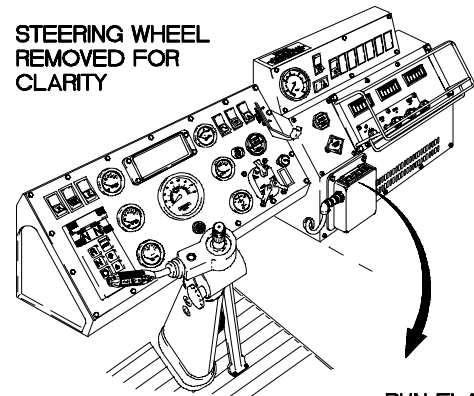

42M0202A

m2. FOUR CENTRAL TIRE INFLATION SYSTEM (CTIS) ECU INDICATOR LIGHTS FLASHING (CONT)

KNOWN INFO
Air pressure at wet tank OK. Tires OK. CTIS wheel seals OK.
POSSIBLE PROBLEMS
Faulty kneeling valve(s) at front wheel(s). Faulty CTIS wheel valve(s). Faulty air hoses from quick release valve to affected wheel(s). Faulty front axle quick release valve. Faulty rear axle quick release valve(s). Faulty rear axle quick release valve fittings. Faulty intermediate axle quick release valve fittings. Faulty intermediate axle tee fittings. Faulty front axle quick release valve fittings. Faulty front tee fittings. Faulty manifold valve assembly delivery port fittings. Faulty cab floor air hose fittings. Faulty manifold valve assembly. Faulty CTIS ECU.

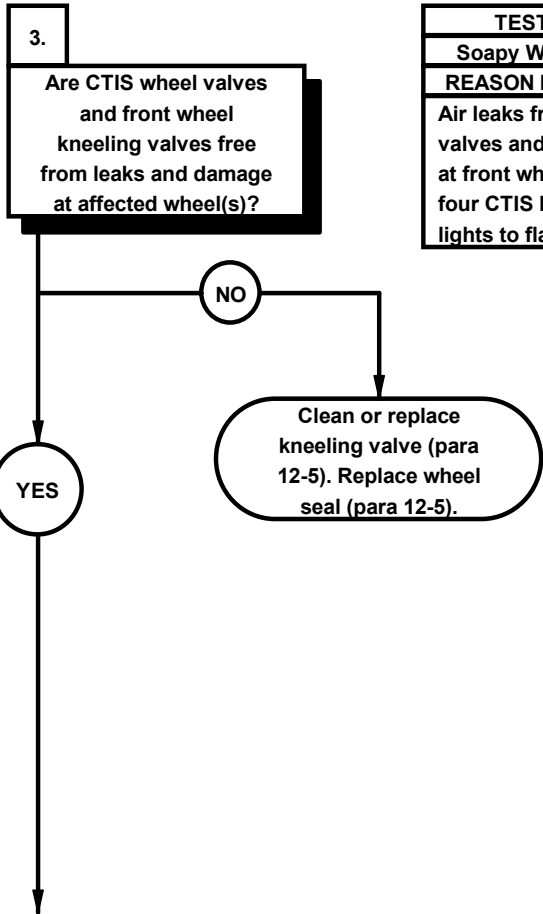

TEST OPTIONS
Soapy Water Leak Test
REASON FOR QUESTION
Air leaks from wheel valves and kneeling valve at front wheels may cause four CTIS ECU indicator lights to flash.



SOAPY WATER LEAK TEST

- (1) If front wheel is leaking, ensure kneeling valve is tight and secure in valve seat.
- (2) Apply soapy water to kneeling valve and check for leaks.
- (3) Apply soapy water solution to fittings on either side of wheel valve and observe fittings for bubbles indicating leaks.
- (4) With wheel valve still connected to tire, disconnect wheel valve air supply hose from hub at banjo fitting.
- (5) Place open end of air supply hose in container of water. Look for bubbles. Persistent bubbles from air supply hose indicate leaking wheel valve.
- (6) Connect air supply hose to hub at banjo fitting.

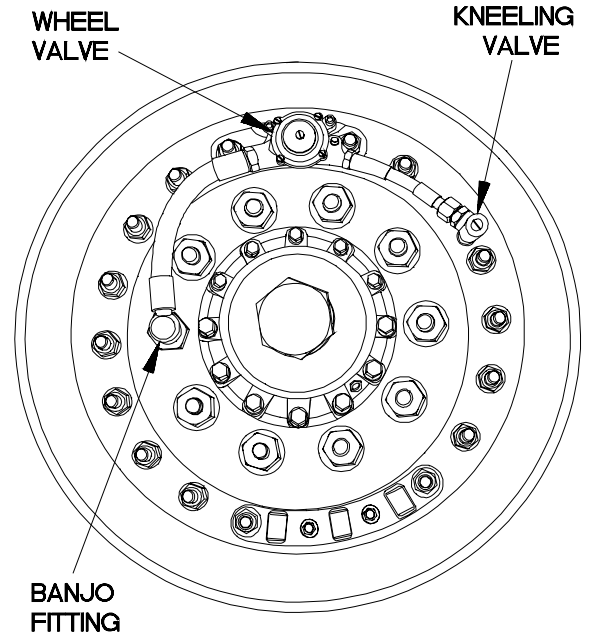

X2M0203A

m2. FOUR CENTRAL TIRE INFLATION SYSTEM (CTIS) ECU INDICATOR LIGHTS FLASHING (CONT)

KNOWN INFO
Air pressure at wet tank OK. Tires OK. CTIS wheel seals OK. Kneeling valves at front wheels OK. CTIS wheel valves OK.
POSSIBLE PROBLEMS
Faulty air hoses from quick release valve to affected wheel(s). Faulty front axle quick release valve. Faulty rear axle quick release valve(s). Faulty rear axle quick release valve fittings. Faulty intermediate axle quick release valve fittings. Faulty intermediate axle tee fittings. Faulty front axle quick release valve fittings. Faulty front tee fittings. Faulty manifold valve assembly delivery port fittings. Faulty cab floor air hose fittings. Faulty manifold valve assembly. Faulty CTIS ECU.

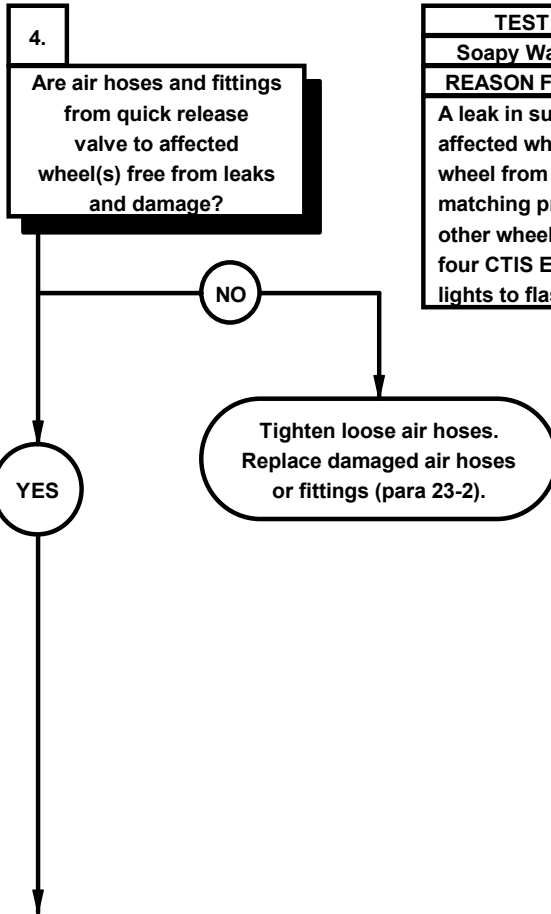

TEST OPTIONS
Soapy Water Leak Test
REASON FOR QUESTION
A leak in supply hose to affected wheel will prevent wheel from coming to matching pressure with all other wheels and will cause four CTIS ECU indicator lights to flash.



SOAPY WATER LEAK TEST

- (1) If affected wheel is on intermediate axle:
 - (a) Apply soapy water solution to air supply fittings at affected wheel(s).
 - (b) Select RUN FLAT at CTIS ECU (TM 9-2320-366-10-1).
 - (c) Check for bubbles indicating leaks at fittings.
 - (d) Inspect air hose from wheel to quick release valve for leaks and damage.
- (2) If affected wheel is on front axle:
 - (a) Apply soapy water solution to air supply fittings at affected wheel(s) and at frame adapter.

NOTE

CTIS air supply is front fitting on left front wheel; back fitting on right front wheel.

- (b) Select RUN FLAT at CTIS ECU (TM 9-2320-366-10-1).
- (c) Check for bubbles indicating leaks at fittings.
- (d) Inspect air hose from frame adapter to quick release valve for leaks and damage.

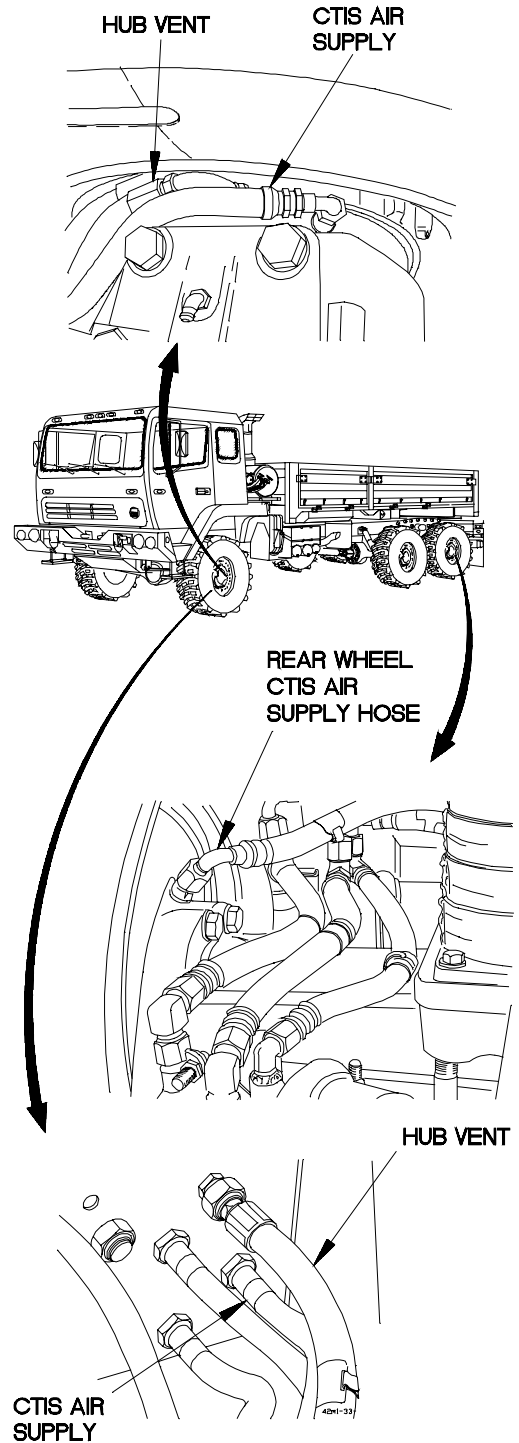

42M0204A

m2. FOUR CENTRAL TIRE INFLATION SYSTEM (CTIS) ECU INDICATOR LIGHTS FLASHING (CONT)

KNOWN INFO
Air pressure at wet tank OK. Tires OK. CTIS wheel seals OK. Kneeling valves at front wheels OK. CTIS wheel valves OK. Air hoses from quick release valve to affected wheels OK.
POSSIBLE PROBLEMS
Faulty front axle quick release valve. Faulty rear axle quick release valve(s). Faulty rear axle quick release valve fittings. Faulty intermediate axle quick release valve fittings. Faulty intermediate axle tee fittings. Faulty front axle quick release valve fittings. Faulty front tee fittings. Faulty manifold valve assembly delivery port fittings. Faulty cab floor air hose fittings. Faulty manifold valve assembly. Faulty CTIS ECU.

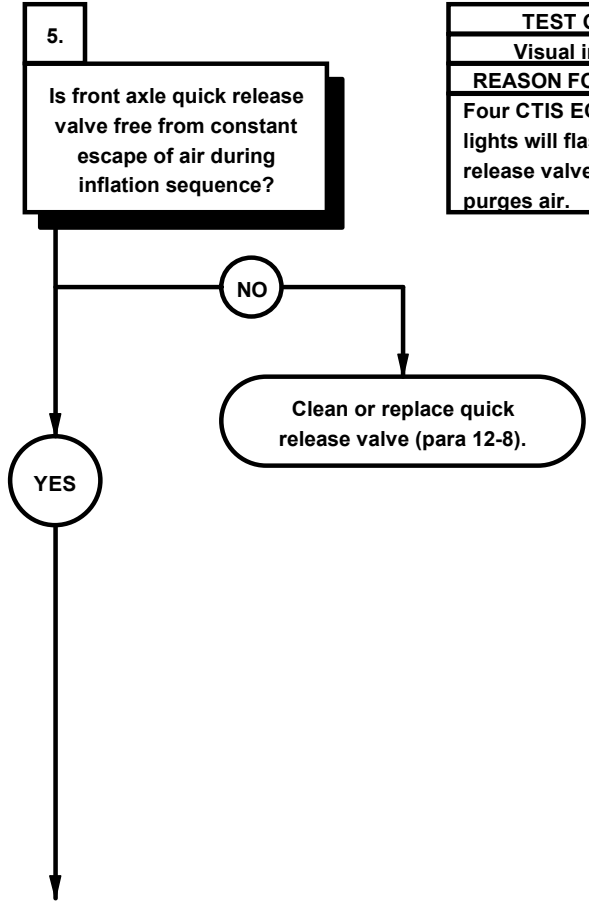

TEST OPTIONS
Visual inspection
REASON FOR QUESTION
Four CTIS ECU indicator lights will flash if quick release valve continually purges air.



- (1) Select RUN FLAT at CTIS ECU (TM 9-2320-366-10-1).
- (2) Check front axle quick release valve for constant escape of air during inflation sequence.
- (3) If air escapes from quick release valve exhaust port during inflation attempt, quick release valve diaphragm is damaged or a foreign object is lodged under diaphragm preventing it from closing.

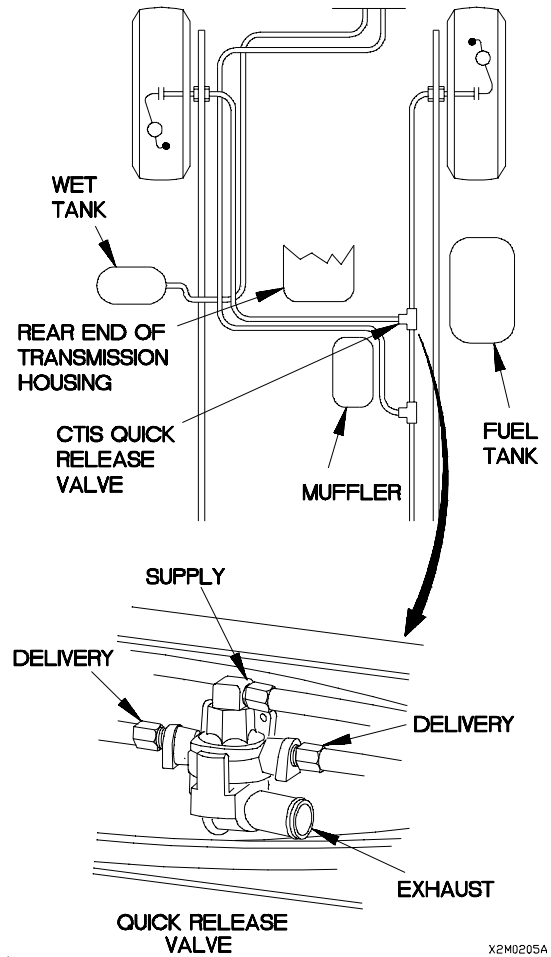
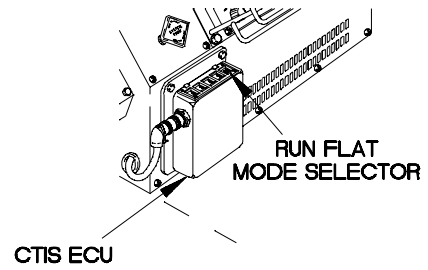

X2M0205A

m2. FOUR CENTRAL TIRE INFLATION SYSTEM (CTIS) ECU INDICATOR LIGHTS FLASHING (CONT)

KNOWN INFO
Air pressure at wet tank OK. Tires OK. CTIS wheel seals OK. Kneeling valves at front wheels OK. CTIS wheel valves OK. Air hoses from quick release valve to affected wheels OK. Front axle quick release valve OK.
POSSIBLE PROBLEMS
Faulty rear axle quick release valve(s). Faulty rear axle quick release valve fittings. Faulty intermediate axle quick release valve fittings. Faulty intermediate axle tee fittings. Faulty front axle quick release valve fittings. Faulty front tee fittings. Faulty manifold valve assembly delivery port fittings. Faulty cab floor air hose fittings. Faulty manifold valve assembly. Faulty CTIS ECU.

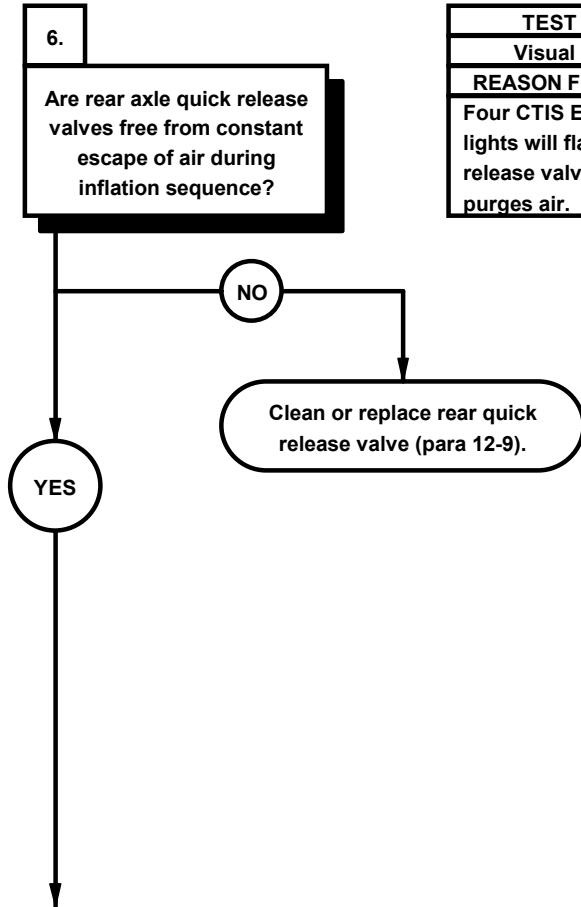

TEST OPTIONS
Visual inspection
REASON FOR QUESTION
Four CTIS ECU indicator lights will flash if quick release valve continually purges air.



- (1) Select RUN FLAT at CTIS ECU (TM 9-2320-366-10-1).
- (2) Check rear axle quick release valve for constant escape of air during inflation sequence.
- (3) If air escapes from quick release valve exhaust port during inflation attempt, quick release valve diaphragm is damaged or a foreign object is lodged under diaphragm preventing it from closing.

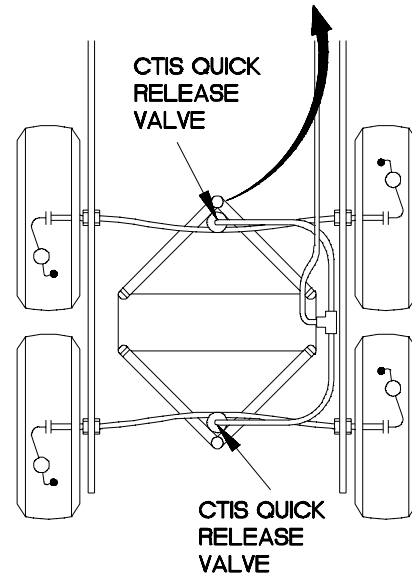
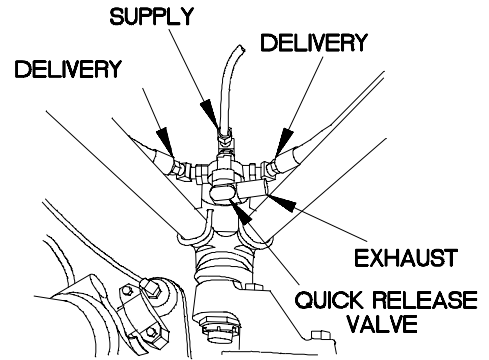
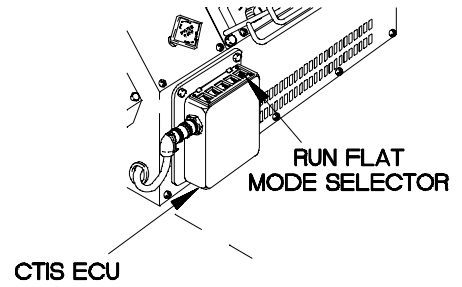

4EM0206A

m2. FOUR CENTRAL TIRE INFLATION SYSTEM (CTIS) ECU INDICATOR LIGHTS FLASHING (CONT)

KNOWN INFO
Air pressure at wet tank OK. Tires OK. CTIS wheel seals OK. Kneeling valves at front wheels OK. CTIS wheel valves OK. Air hoses from quick release valve to affected wheels OK. Front axle quick release valve OK. Rear axle quick release valves OK.
POSSIBLE PROBLEMS
Faulty rear axle quick release valve fittings. Faulty intermediate axle quick release valve fittings. Faulty intermediate axle tee fittings. Faulty front axle quick release valve fittings. Faulty front tee fittings. Faulty manifold valve assembly delivery port fittings. Faulty cab floor air hose fittings. Faulty manifold valve assembly. Faulty CTIS ECU.

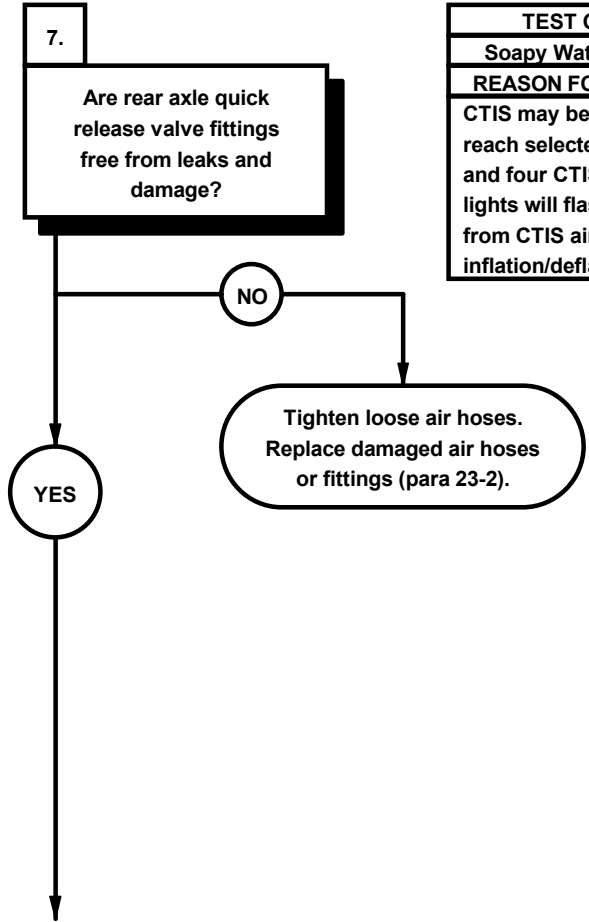

TEST OPTIONS
Soapy Water Leak Test
REASON FOR QUESTION
CTIS may be unable to reach selected pressure and four CTIS ECU indicator lights will flash if air leaks from CTIS air hoses during inflation/deflation sequence.



SOAPY WATER LEAK TEST

- (1) Select RUN FLAT at CTIS ECU (TM 9-2320-366-10-1) and listen for obvious air escape in CTIS system.
- (2) If obvious air escape is heard, perform repair at damaged area. If no obvious air escape is heard, proceed to quick release valve leak check.
- (3) Apply soapy water solution to quick release valve fittings at rear axle.
- (4) Check for bubbles indicating leaks.

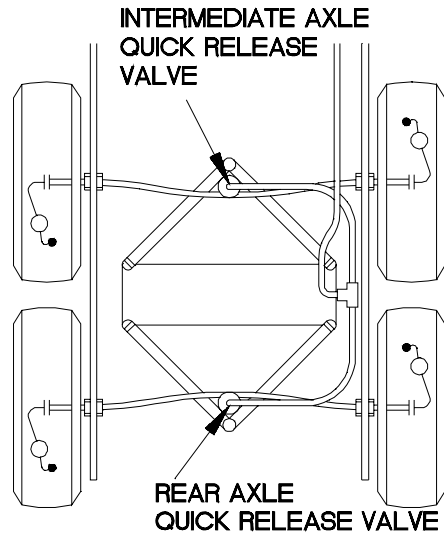

42M0207A

m2. FOUR CENTRAL TIRE INFLATION SYSTEM (CTIS) ECU INDICATOR LIGHTS FLASHING (CONT)

KNOWN INFO
Air pressure at wet tank OK. Tires OK. CTIS wheel seals OK. Kneeling valves at front wheels OK. CTIS wheel valves OK. Air hoses from quick release valve to affected wheels OK. Front axle quick release valve OK. Rear axle quick release valves OK. Rear axle quick release valve fittings OK.
POSSIBLE PROBLEMS
Faulty intermediate axle quick release valve fittings. Faulty intermediate axle tee fittings. Faulty front axle quick release valve fittings. Faulty front tee fittings. Faulty manifold valve assembly delivery port fittings. Faulty cab floor air hose fittings. Faulty manifold valve assembly. Faulty CTIS ECU.

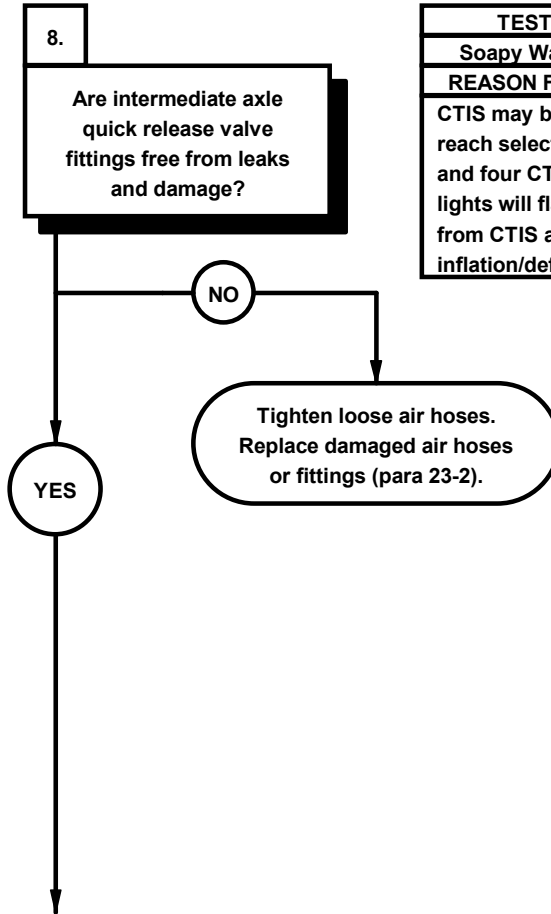

TEST OPTIONS
Soapy Water Leak Test
REASON FOR QUESTION
CTIS may be unable to reach selected pressure and four CTIS ECU indicator lights will flash if air leaks from CTIS air hoses during inflation/deflation sequence.



SOAPY WATER LEAK TEST

- (1) Select RUN FLAT at CTIS ECU (TM 9-2320-366-10-1) and listen for obvious air escape in CTIS system.
- (2) If obvious air escape is heard, perform repair at damaged area. If no obvious air escape is heard, proceed to quick release valve leak check.
- (3) Apply soapy water solution to quick release valve fittings at intermediate axle.
- (4) Check for bubbles indicating leaks.

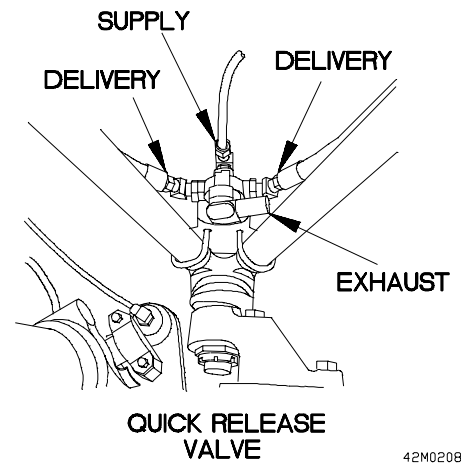

42M0208A

m2. FOUR CENTRAL TIRE INFLATION SYSTEM (CTIS) ECU INDICATOR LIGHTS FLASHING (CONT)

KNOWN INFO
Air pressure at wet tank OK. Tires OK. CTIS wheel seals OK. Kneeling valves at front wheels OK. CTIS wheel valves OK. Air hoses from quick release valve to affected wheels OK. Front axle quick release valve OK. Rear axle quick release valves OK. Rear axle quick release valve fittings OK. Intermediate axle quick release valve fittings OK.
POSSIBLE PROBLEMS
Faulty intermediate axle tee fittings. Faulty front axle quick release valve fittings. Faulty front tee fittings. Faulty manifold valve assembly delivery port fittings. Faulty cab floor air hose fittings. Faulty manifold valve assembly. Faulty CTIS ECU.

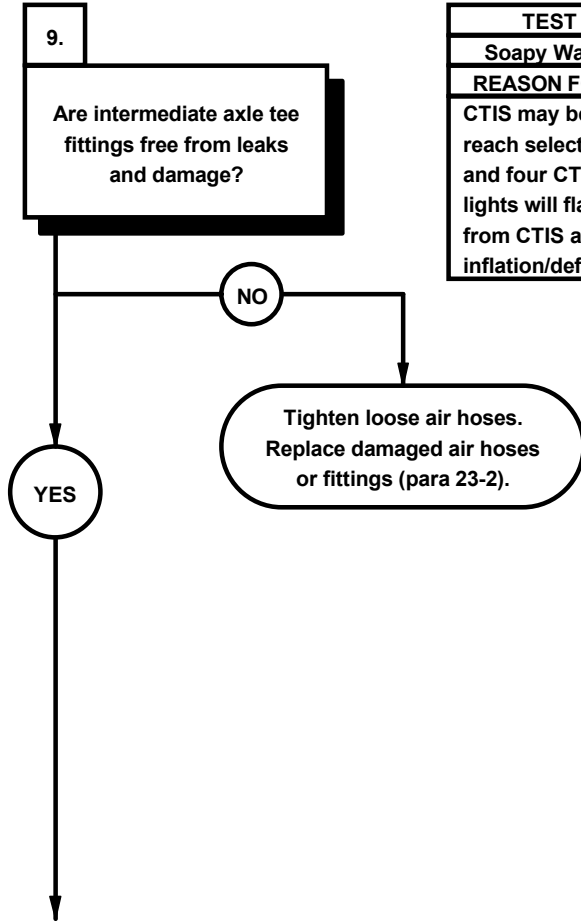

TEST OPTIONS
Soapy Water Leak Test
REASON FOR QUESTION
CTIS may be unable to reach selected pressure and four CTIS ECU indicator lights will flash if air leaks from CTIS air hoses during inflation/deflation sequence.



SOAPY WATER LEAK TEST	
(1)	Apply soapy water solution to intermediate axle tee fittings.
(2)	Select RUN FLAT at CTIS ECU (TM 9-2320-366-10-1).
(3)	Check for bubbles indicating leaks.

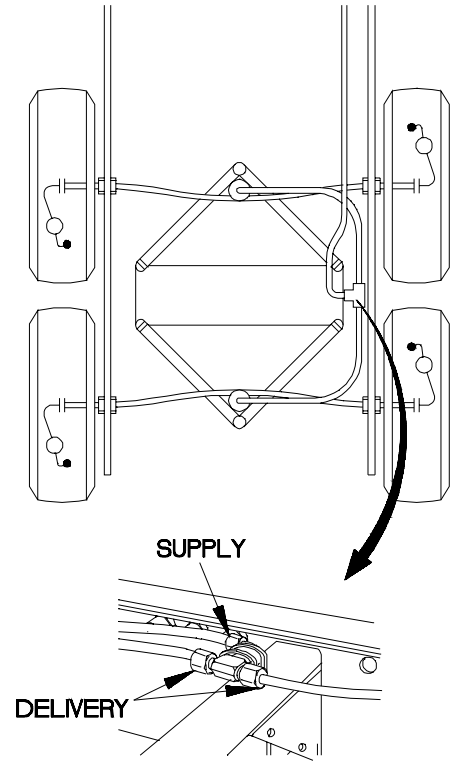

42M0209A

m2. FOUR CENTRAL TIRE INFLATION SYSTEM (CTIS) ECU INDICATOR LIGHTS FLASHING (CONT)

KNOWN INFO
Air pressure at wet tank OK. Tires OK. CTIS wheel seals OK. Kneeling valves at front wheels OK. CTIS wheel valves OK. Air hoses from quick release valve to affected wheels OK. Front axle quick release valve OK. Rear axle quick release valves OK. Rear axle quick release valve fittings OK. Intermediate axle quick release valve fittings OK. Intermediate axle tee fittings OK.
POSSIBLE PROBLEMS
Faulty front axle quick release valve fittings. Faulty front tee fittings. Faulty manifold valve assembly delivery port fittings. Faulty cab floor air hose fittings. Faulty manifold valve assembly. Faulty CTIS ECU.

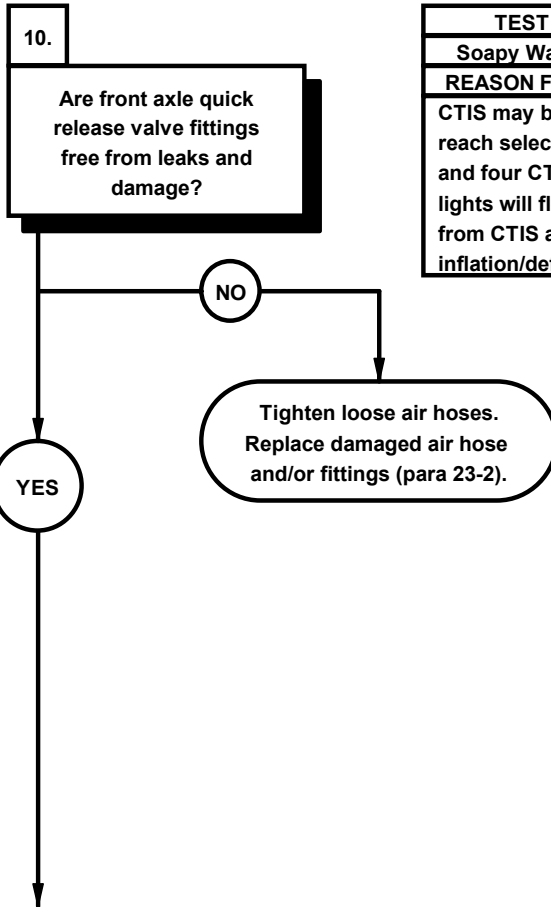

TEST OPTIONS
Soapy Water Leak Test
REASON FOR QUESTION
CTIS may be unable to reach selected pressure and four CTIS ECU indicator lights will flash if air leaks from CTIS air hoses during inflation/deflation sequence.



SOAPY WATER LEAK TEST	
	(1) Apply soapy water solution to front quick release valve fittings.
	(2) Select RUN FLAT at CTIS ECU (TM 9-2320-366-10-1).
	(3) Check for bubbles indicating leaks.

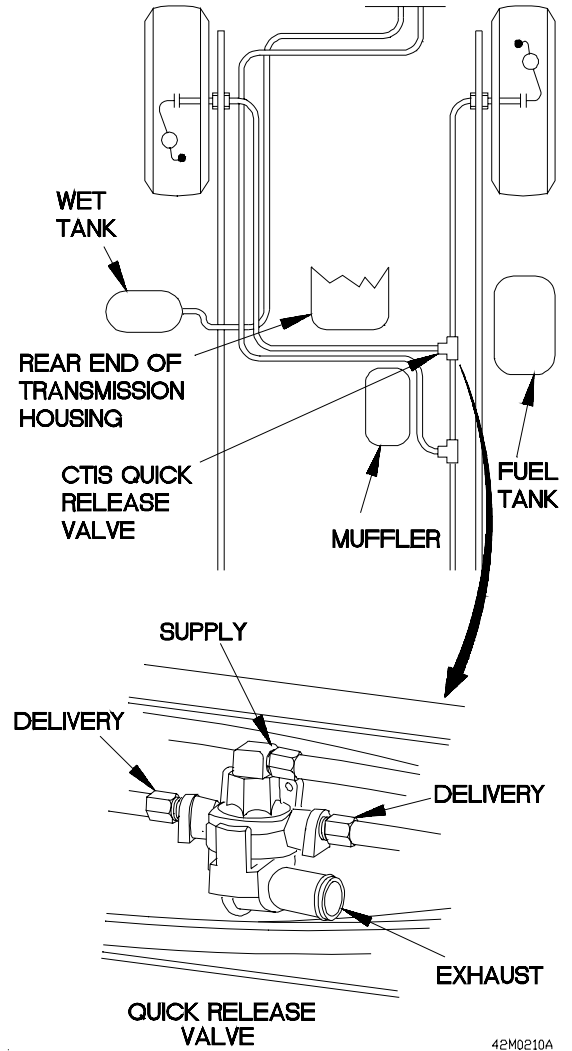

42M0210A

m2. FOUR CENTRAL TIRE INFLATION SYSTEM (CTIS) ECU INDICATOR LIGHTS FLASHING (CONT)

KNOWN INFO
Air pressure at wet tank OK. Tires OK. CTIS wheel seals OK. Kneeling valves at front wheels OK. CTIS wheel valves OK. Air hoses from quick release valve to affected wheels OK. Front axle quick release valve OK. Rear axle quick release valves OK. Rear axle quick release valve fittings OK. Intermediate axle quick release valve fittings OK. Intermediate axle tee fittings OK. Front quick release valve fittings OK.
POSSIBLE PROBLEMS
Faulty front tee fittings. Faulty manifold valve assembly delivery port fittings. Faulty cab floor air hose fittings. Faulty manifold valve assembly. Faulty CTIS ECU.

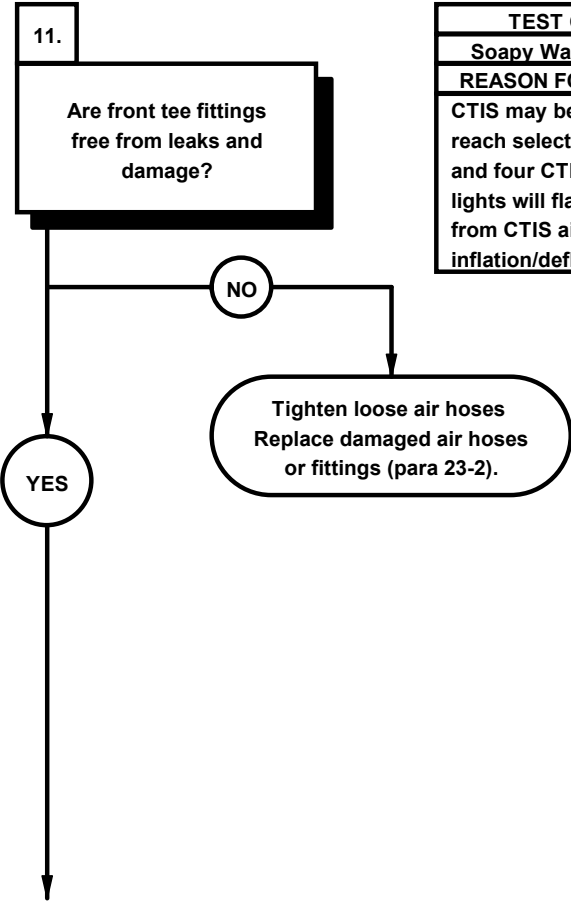

TEST OPTIONS
Soapy Water Leak Test
REASON FOR QUESTION
CTIS may be unable to reach selected pressure and four CTIS ECU indicator lights will flash if air leaks from CTIS air hoses during inflation/deflation sequence.



SOAPY WATER LEAK TEST

- (1) Apply soapy water solution to tee fittings at muffler.
- (2) Select RUN FLAT at CTIS ECU (TM 9-2320-366-10-1).
- (3) Check for bubbles indicating leaks.

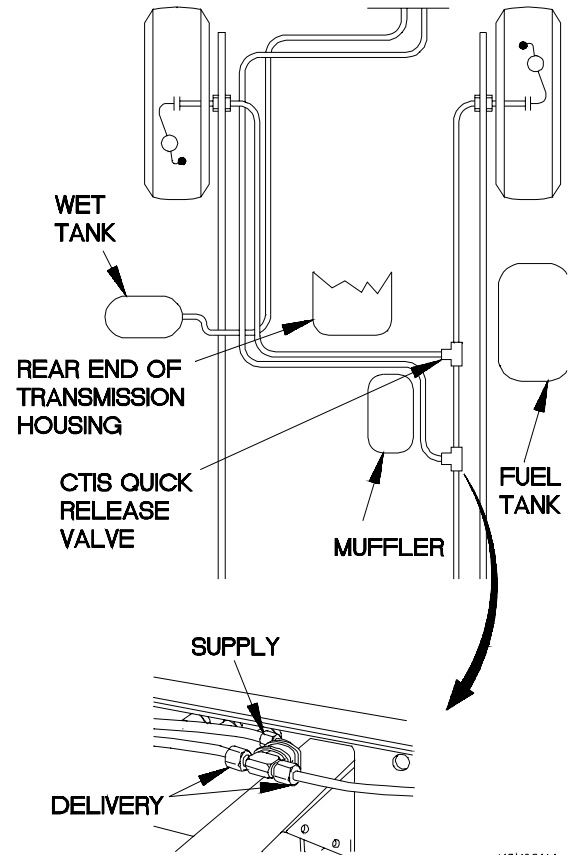

X2M0211A

m2. FOUR CENTRAL TIRE INFLATION SYSTEM (CTIS) ECU INDICATOR LIGHTS FLASHING (CONT)

KNOWN INFO
Air pressure at wet tank OK. Tires OK. CTIS wheel seals OK. Kneeling valves at front wheels OK. CTIS wheel valves OK. Air hoses from quick release valve to affected wheels OK. Front axle quick release valve OK. Rear axle quick release valves OK. Rear axle quick release valve fittings OK. Intermediate axle quick release valve fittings OK. Intermediate axle tee fittings OK. Front quick release valve fittings OK. Front tee fittings OK.
POSSIBLE PROBLEMS
Faulty manifold valve assembly delivery port fittings. Faulty cab floor air hose fittings. Faulty manifold valve assembly. Faulty CTIS ECU.

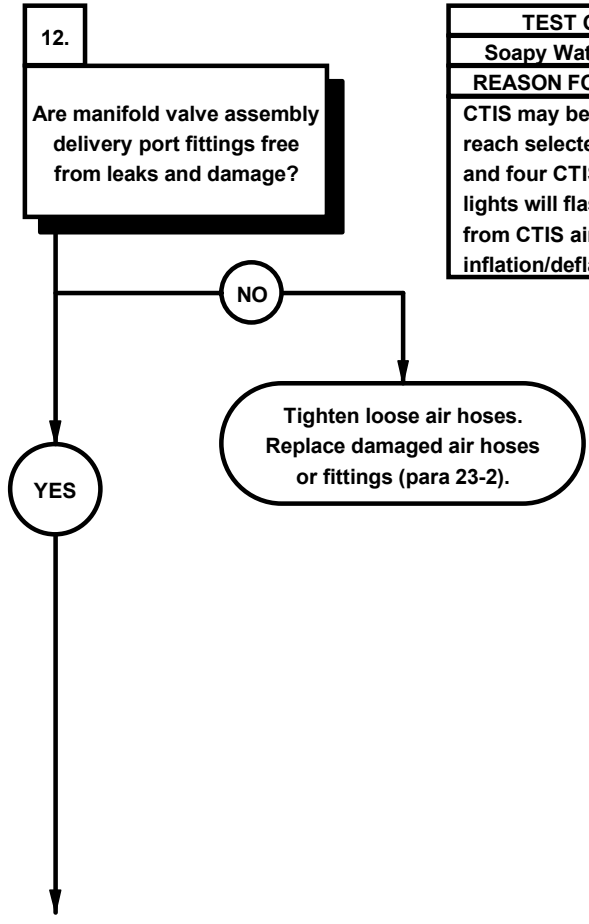

TEST OPTIONS
Soapy Water Leak Test
REASON FOR QUESTION
CTIS may be unable to reach selected pressure and four CTIS ECU indicator lights will flash if air leaks from CTIS air hoses during inflation/deflation sequence.



SOAPY WATER LEAK TEST

- (1) Remove kick panel (para 16-3).
- (2) Apply soapy water solution to manifold valve assembly delivery port fittings.
- (3) Select RUN FLAT at CTIS ECU (TM 9-2320-366-10-1).
- (4) Check for bubbles indicating leaks.

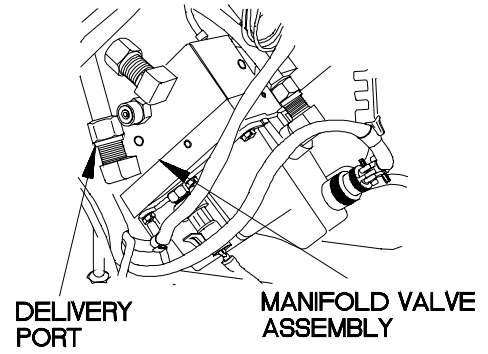

X2M0212A

m2. FOUR CENTRAL TIRE INFLATION SYSTEM (CTIS) ECU INDICATOR LIGHTS FLASHING (CONT)

KNOWN INFO
Air pressure at wet tank OK. Tires OK. CTIS wheel seals OK. Kneeling valves at front wheels OK. CTIS wheel valves OK. Air hoses from quick release valve to affected wheels OK. Front axle quick release valve OK. Rear axle quick release valves OK. Rear axle quick release valve fittings OK. Intermediate axle quick release valve fittings OK. Intermediate axle tee fittings OK. Front quick release valve fittings OK. Front tee fittings OK. Manifold valve assembly delivery port fittings OK.
POSSIBLE PROBLEMS
Faulty cab floor air hose fittings. Faulty manifold valve assembly. Faulty CTIS ECU.

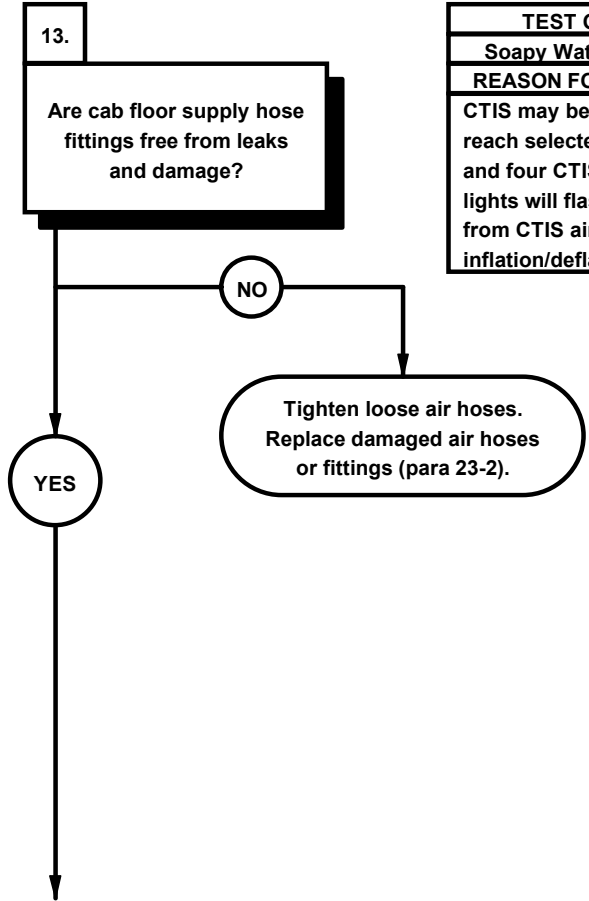

TEST OPTIONS
Soapy Water Leak Test
REASON FOR QUESTION
CTIS may be unable to reach selected pressure and four CTIS ECU indicator lights will flash if air leaks from CTIS air hoses during inflation/deflation sequence.



SOAPY WATER LEAK TEST

- (1) Remove two screws and washers from front grille.
- (2) Remove screw and washer from front grille.
- (3) Remove front grille from cab.
- (4) Apply soapy water solution to cab floor supply hose fittings.
- (5) Select RUN FLAT at CTIS ECU (TM 9-2320-366-10-1).
- (6) Check for bubbles indicating leaks.
- (7) Position front grille on cab with washer and screw.
- (8) Position two washers and screws in front grille.
- (9) Tighten screw to 48-60 lb-in. (5-7 N·m).
- (10) Tighten two screws to 24 lb-in. (3 N·m).

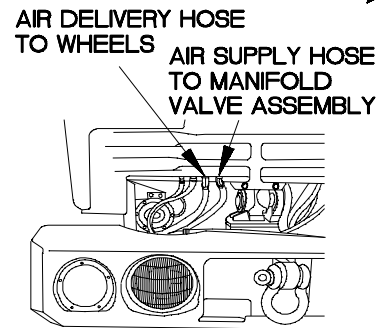
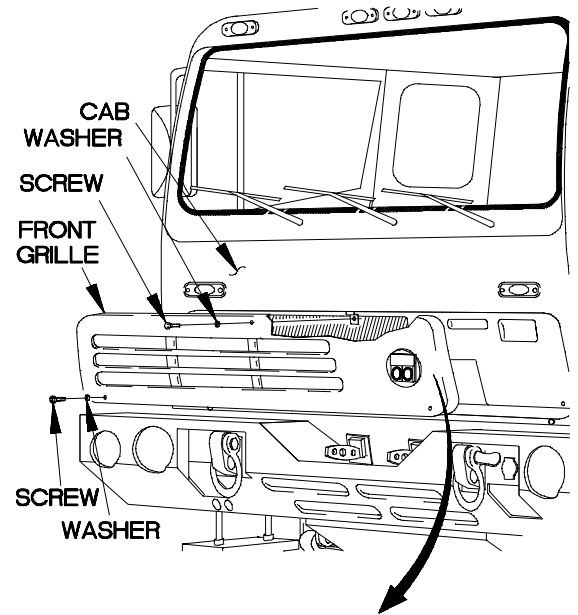

X2m0213a

m2. FOUR CENTRAL TIRE INFLATION SYSTEM (CTIS) ECU INDICATOR LIGHTS FLASHING (CONT)

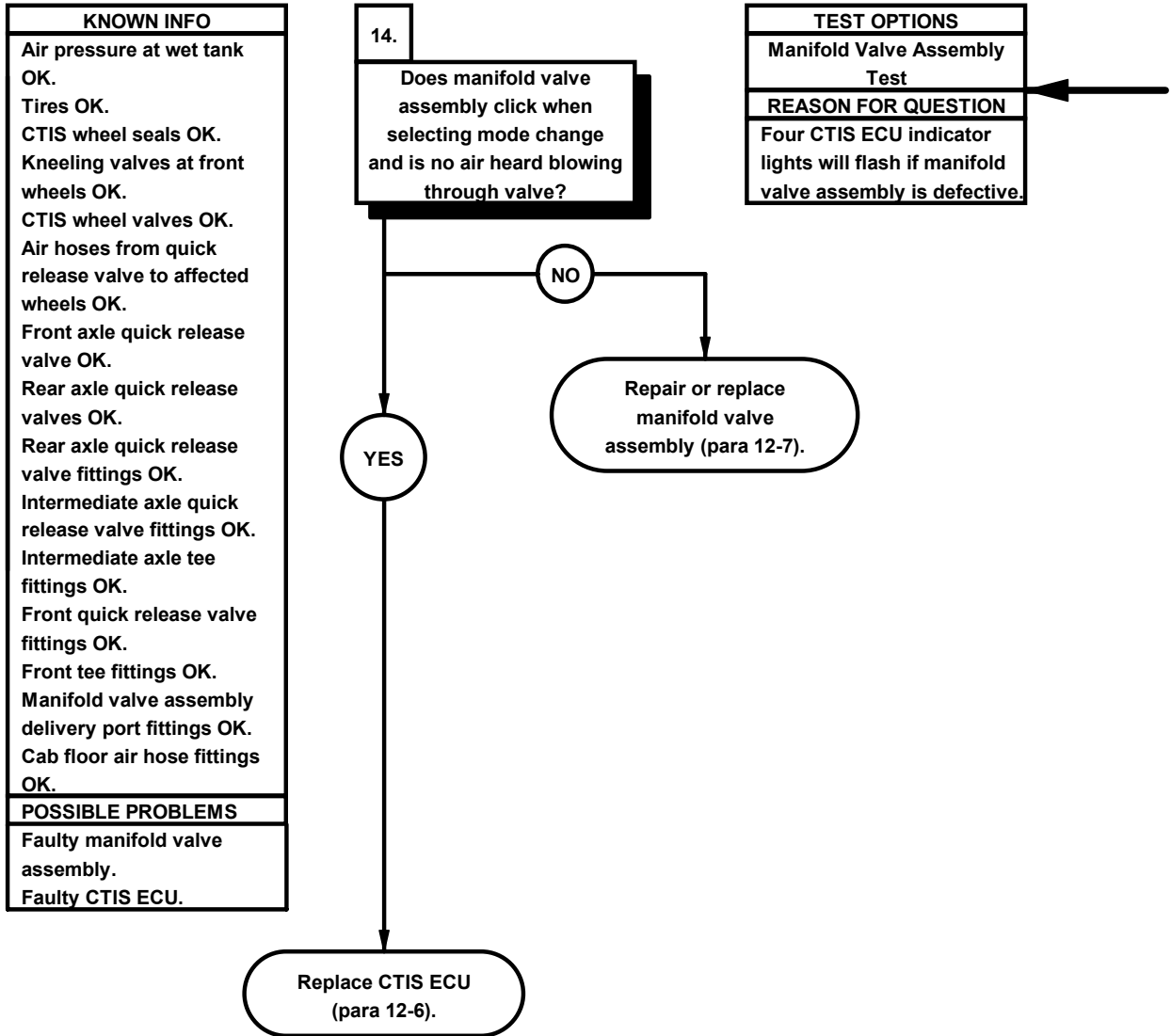

MANIFOLD VALVE ASSEMBLY TEST

- (1) Select RUN FLAT at CTIS ECU (TM 9-2320-366-10-1).
- (2) Check manifold valve assembly by listening for clicking when selecting mode change. If no clicking is heard or if air blows through manifold valve assembly, manifold valve assembly is faulty.
- (3) If manifold valve is ok, ECU may be faulty.
- (4) Install kick panel (para 16-3).

MANIFOLD VALVE ASSEMBLY

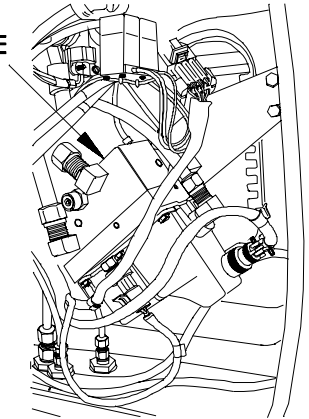

42M0214A

m3. FIVE CENTRAL TIRE INFLATION SYSTEM (CTIS) ECU INDICATOR LIGHTS FLASHING

INITIAL SETUP

Equipment Conditions

Engine shut down (TM 9-2320-366-10-1).
Kick panel removed (para 16-3).

Tools and Special Tools

Tool Kit, Genl Mech (Item 44, Appendix C)
Multimeter, Digital (Item 22, Appendix C)
Goggles, Industrial (Item 15, Appendix C)

KNOWN INFO
Front and rear air gages read 120 psi.
POSSIBLE PROBLEMS
Faulty air hose or fittings. Faulty front axle CTIS quick release valve. Faulty intermediate axle CTIS quick release valve. Faulty rear axle CTIS quick release valve. Faulty wheel valve. Faulty front wheel kneeling valve. Faulty wheel seals. Faulty electrical system.

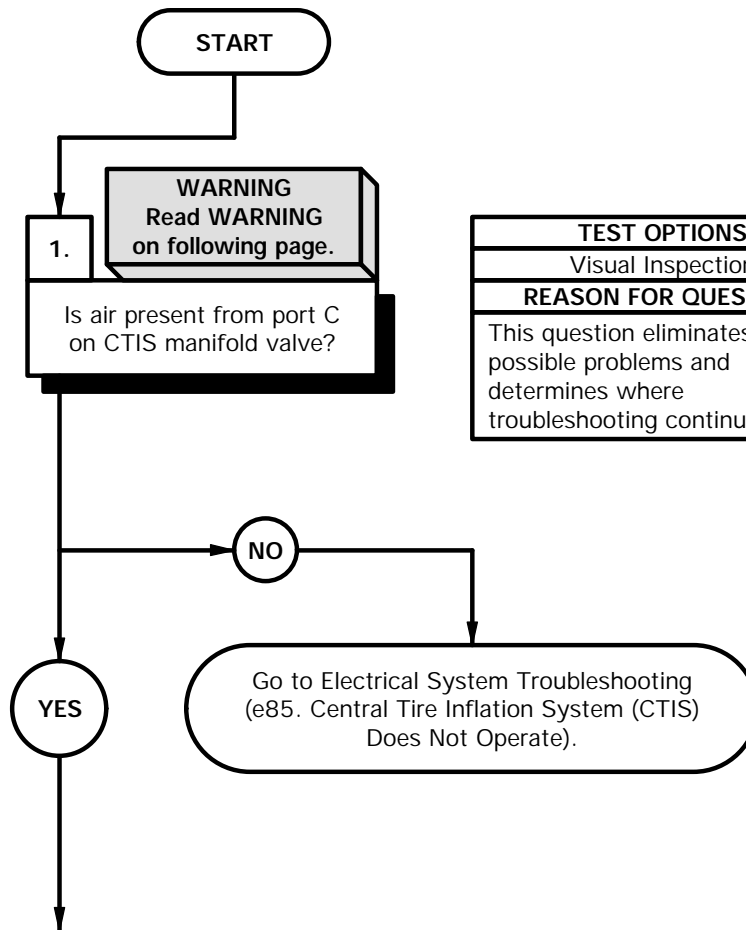

TEST OPTIONS
Visual Inspection
REASON FOR QUESTION
This question eliminates possible problems and determines where troubleshooting continues.

WARNING

The sudden release of high pressure air can cause damage to eyes. Wear appropriate eye protection when working near pressurized air. Failure to comply may result in injury to personnel.

- (1) Disconnect CTIS manifold output hose from CTIS manifold valve port C.
- (2) Start engine (TM 9-2320-366-10-1).
- (3) Select CTIS inflation mode (TM 9-2320-366-10-1).
- (4) Wait for CTIS to cycle and check for quick bursts of air to expel from CTIS manifold valve port C.
- (5) Check for five CTIS ECU indicator lights flashing.
- (6) If air does not expel from CTIS manifold valve or CTIS ECU does not have five flashing indicator lights, go to Electrical System Troubleshooting (e85. Central Tire Inflation System (CTIS) Does Not Operate).
- (7) Shut down engine (TM 9-2320-366-10-1).
- (8) Connect CTIS manifold output hose to CTIS manifold valve port C.
- (9) Install kick panel (para 16-3).

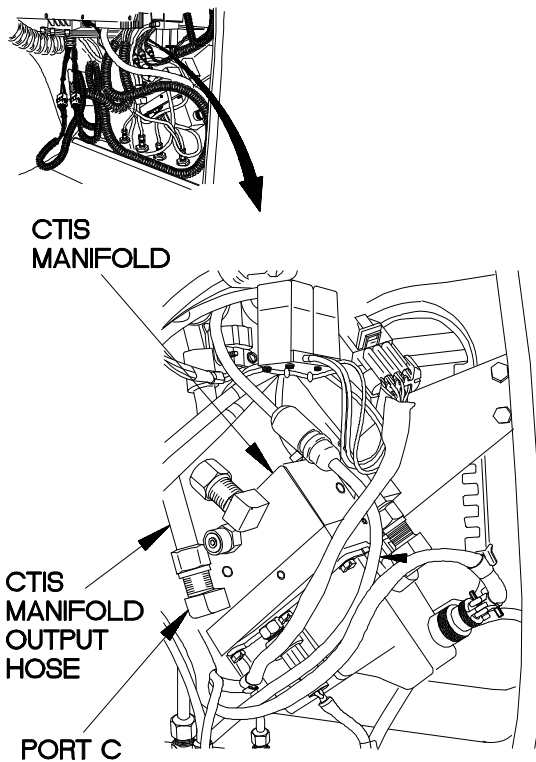

XBM0301B

m3. FIVE CENTRAL TIRE INFLATION SYSTEM (CTIS) ECU INDICATOR LIGHTS FLASHING (CONT)

KNOWN INFO
Front and rear air gages read 120 psi.
POSSIBLE PROBLEMS
Faulty air hose or fittings. Faulty front axle CTIS quick release valve. Faulty intermediate axle CTIS quick release valve. Faulty rear axle CTIS quick release valve. Faulty wheel valve. Faulty front wheel kneeling valve. Faulty wheel seals. Faulty electrical system.

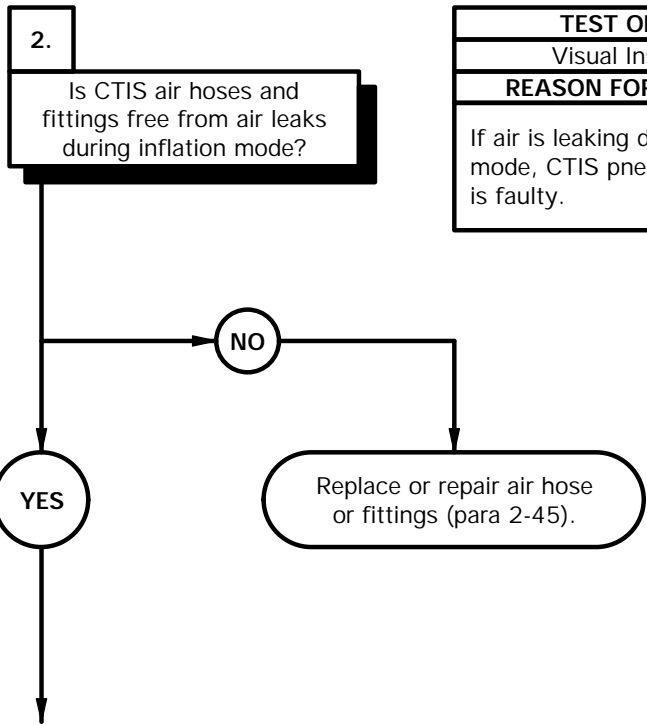

TEST OPTIONS
Visual Inspection
REASON FOR QUESTION
If air is leaking during inflation mode, CTIS pneumatic system is faulty.



NOTE

Five flashing indicator lights indicate a defect in CTIS critical component(s) causing system to shut off. Override cannot be applied but system can be activated by turning vehicle off and then on again.

- (1) Start engine (TM 9-2320-366-10-1).
- (2) Set CTIS ECU to RUN FLAT mode (TM 9-2320-366-10-1).
- (3) Check CTIS air hoses and fittings for leaks (Table 23-2 Central Tire Inflation System (CTIS) Air Hose Locations).
- (4) If any leaks are found, repair or replace CTIS air hose and/or fittings (para 2-45).
- (5) Shut down engine (TM 9-2320-366-10-1).

m3. FIVE CENTRAL TIRE INFLATION SYSTEM (CTIS) ECU INDICATOR LIGHTS FLASHING (CONT)

KNOWN INFO
Front and rear air gages read 120 psi. Air hose and fittings OK.
POSSIBLE PROBLEMS
Faulty front axle CTIS quick release valve. Faulty intermediate axle CTIS quick release valve. Faulty rear axle CTIS quick release valve. Faulty wheel valve. Faulty front wheel kneeling valve. Faulty wheel seals. Faulty electrical system.

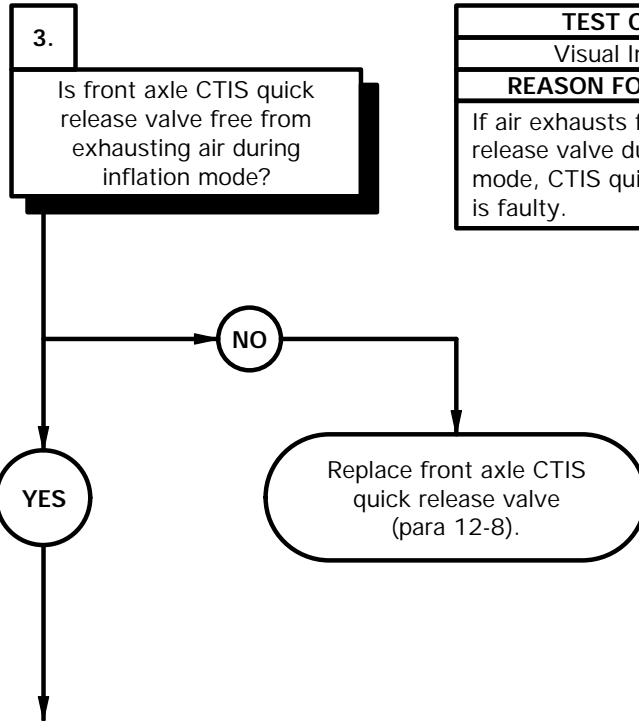

TEST OPTIONS
Visual Inspection
REASON FOR QUESTION
If air exhausts from CTIS quick release valve during inflation mode, CTIS quick release valve is faulty.



- (1) Start engine (TM 9-2320-366-10-1).
- (2) Select CTIS inflation mode (TM 9-2320-366-10-1).
- (3) Check for air escaping from front axle CTIS quick release valve during inflation mode.
- (4) If air is escaping from front axle CTIS quick release valve during inflation mode, replace front axle CTIS quick release valve (para 12-8).
- (5) Shut down engine (TM 9-2320-366-10-1).

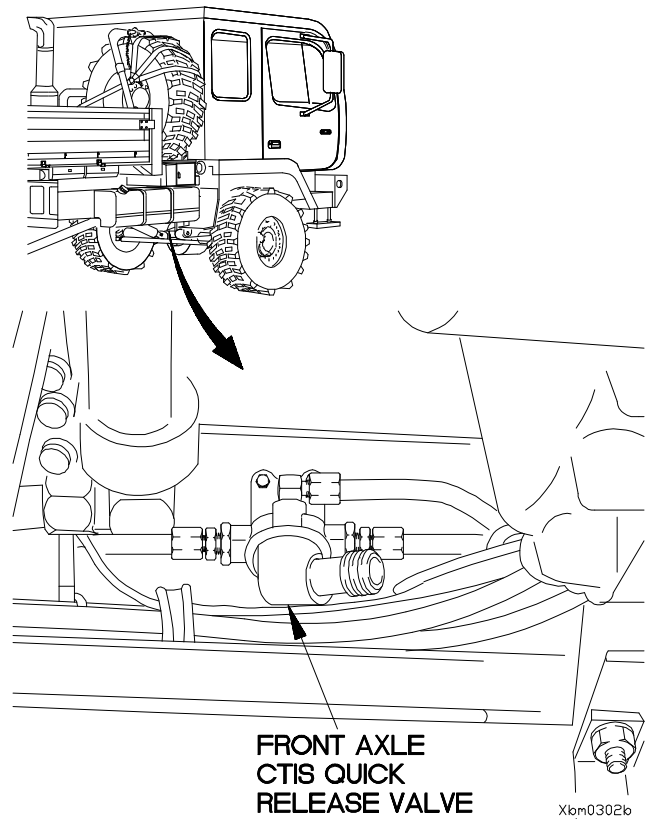

m3. FIVE CENTRAL TIRE INFLATION SYSTEM (CTIS) ECU INDICATOR LIGHTS FLASHING (CONT)

KNOWN INFO
Front and rear air gages read 120 psi. Air hose and fittings OK. Front axle CTIS quick release valve OK.
POSSIBLE PROBLEMS
Faulty intermediate axle CTIS quick release valve. Faulty rear axle CTIS quick release valve. Faulty wheel valve. Faulty front wheel kneeling valve. Faulty wheel seals. Faulty electrical system.

4.
Are intermediate and rear axle CTIS quick release valves free from exhausting air during inflation mode?

TEST OPTIONS
Visual Inspection
REASON FOR QUESTION
If air exhausts from CTIS quick release valve during inflation mode, CTIS quick release valve is faulty.

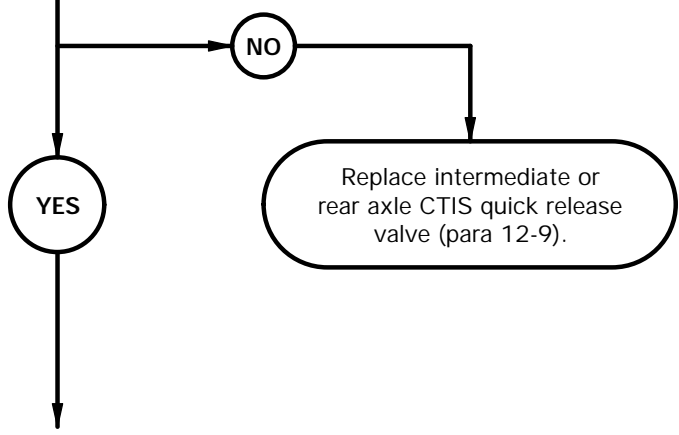

- (1) Start engine (TM 9-2320-366-10-1).
- (2) Select CTIS inflation mode (TM 9-2320-366-10-1).
- (3) Check for air escaping from intermediate and rear axle CTIS quick release valves during inflation mode. (Intermediate CTIS quick release valve shown.)
- (4) If air is escaping from intermediate or rear axle CTIS quick release valve during inflation mode, replace affected CTIS quick release valve (para 12-9).
- (5) Shut down engine (TM 9-2320-366-10-1).

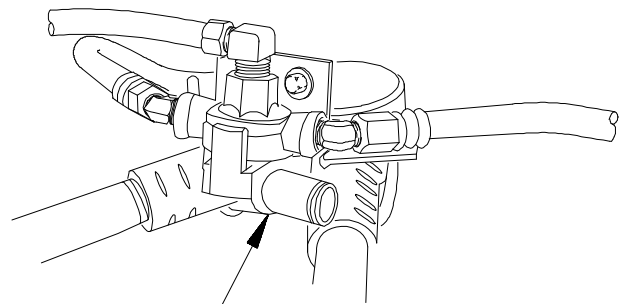
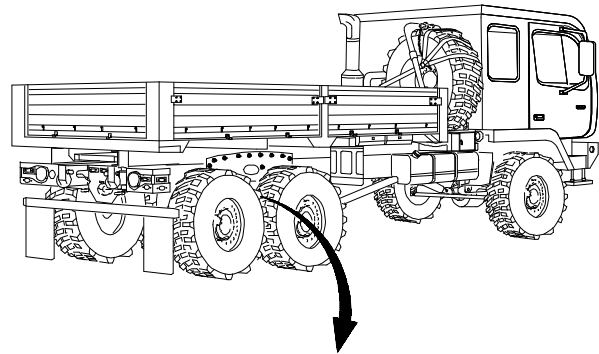

**INTERMEDIATE AXLE
CTIS QUICK RELEASE
VALVE**

46m0303b

m3. FIVE CENTRAL TIRE INFLATION SYSTEM (CTIS) ECU INDICATOR LIGHTS FLASHING (CONT)

KNOWN INFO
Front and rear air gages read 120 psi. Air hose and fittings OK. Front axle CTIS quick release valves OK. Intermediate axle CTIS quick release valve OK. Rear axle CTIS quick release valve OK.
POSSIBLE PROBLEMS
Faulty wheel valve. Faulty front wheel kneeling valve. Faulty wheel seals. Faulty electrical system.

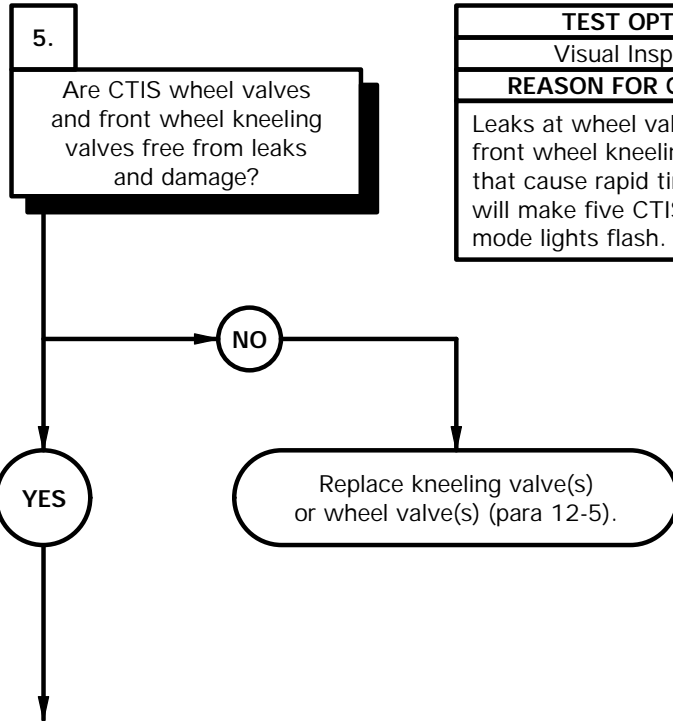

TEST OPTIONS
Visual Inspection
REASON FOR QUESTION
Leaks at wheel valves and front wheel kneeling valve(s) that cause rapid tire deflation will make five CTIS ECU mode lights flash.

- (1) Start engine (TM 9-2320-366-10-1).
- (2) Select CTIS inflation mode (TM 9-2320-366-10-1).
- (3) Listen for audible escape of air at kneeling valve (front wheels only) and CTIS wheel valves on each wheel.
- (4) If audible escape of air is present, replace wheel kneeling valve(s) or wheel valve(s) (para 12-5).
- (5) Shut down engine (TM 9-2320-366-10-1).

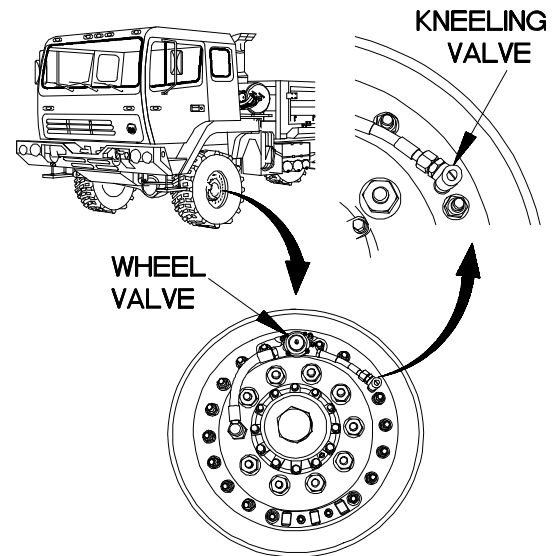

Xbm0304b

m3. FIVE CENTRAL TIRE INFLATION SYSTEM (CTIS) ECU INDICATOR LIGHTS FLASHING (CONT)

KNOWN INFO
Front and rear air gages read 120 psi. Air hose and fittings OK. Front axle CTIS quick release valves OK. Intermediate axle CTIS quick release valve OK. Rear axle CTIS quick release valve OK. Wheel valves OK. Front wheel kneeling valves OK.
POSSIBLE PROBLEMS
Faulty wheel seals. Faulty electrical system.

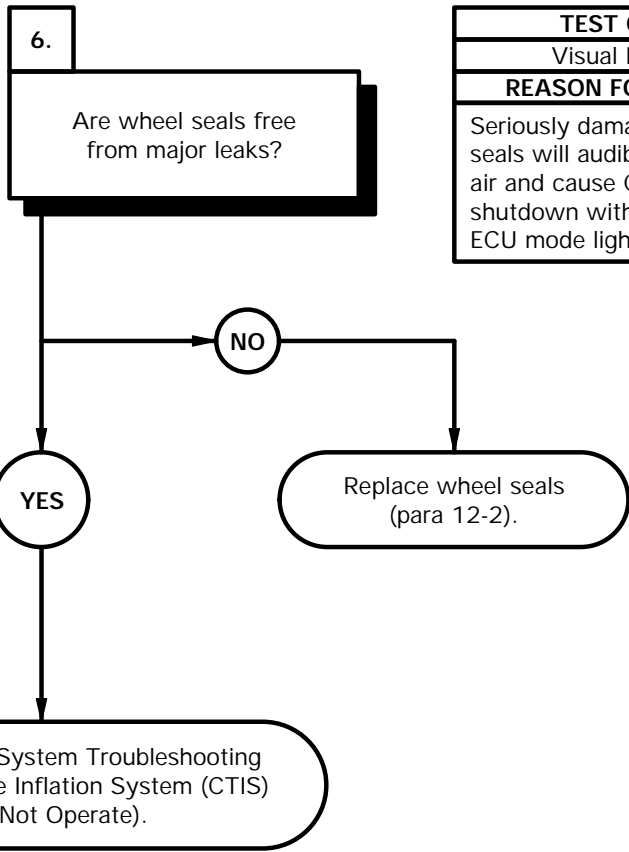

TEST OPTIONS
Visual Inspection
REASON FOR QUESTION
Seriously damaged wheel seals will audibly exhaust air and cause CTIS to shutdown with five CTIS ECU mode lights flashing.



- (1) Move vehicle until hub plug on wheel is in 12 o'clock position.
- (2) Remove wheel hub plug.
- (3) Start engine (TM 9-2320-366-10-1).
- (4) Select CTIS inflation mode (TM 9-2320-366-10-1).
- (5) Listen at wheel hub for audible escape of air.
- (6) If audible escape of air is present, replace wheel seal (para 12-2).
- (7) Install wheel hub plug.
- (8) Perform steps 1 through 5 on remaining wheels.
- (9) If no air is audibly present from wheel hub, Go to Electrical System Troubleshooting (e85. Central Tire Inflation System (CTIS) Does Not Operate).
- (10) Shut down engine (TM 9-2320-366-10-1).

HUB PLUG

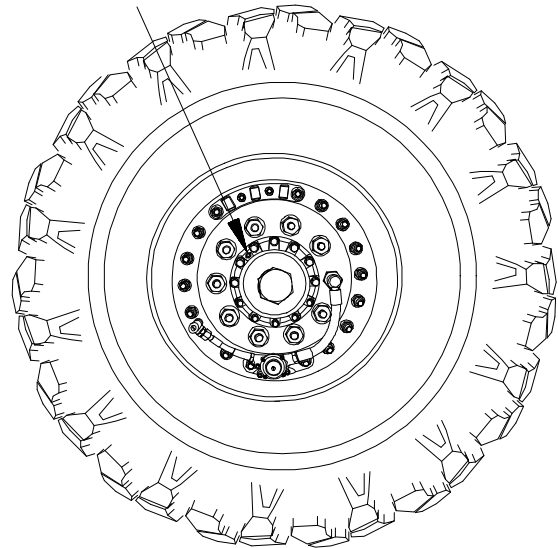

Xbm0305b

m4. CENTRAL TIRE INFLATION SYSTEM (CTIS) REPEATEDLY RESUMES CYCLING 30 SECONDS AFTER INDICATOR LIGHTS STOP FLASHING	
INITIAL SETUP	
Equipment Conditions Engine shut down (TM 9-2320-366-10-1).	Tools and Special Tools Tool Kit, Genl Mech (Item 46, Appendix C) Goggles, Industrial (Item 15, Appendix C) Gage, Tire Pressure (Item 11, Appendix C) Pan, Wash (Item 25, Appendix C)
Materials/Parts Soap, Laundry (Item 63, Appendix D)	

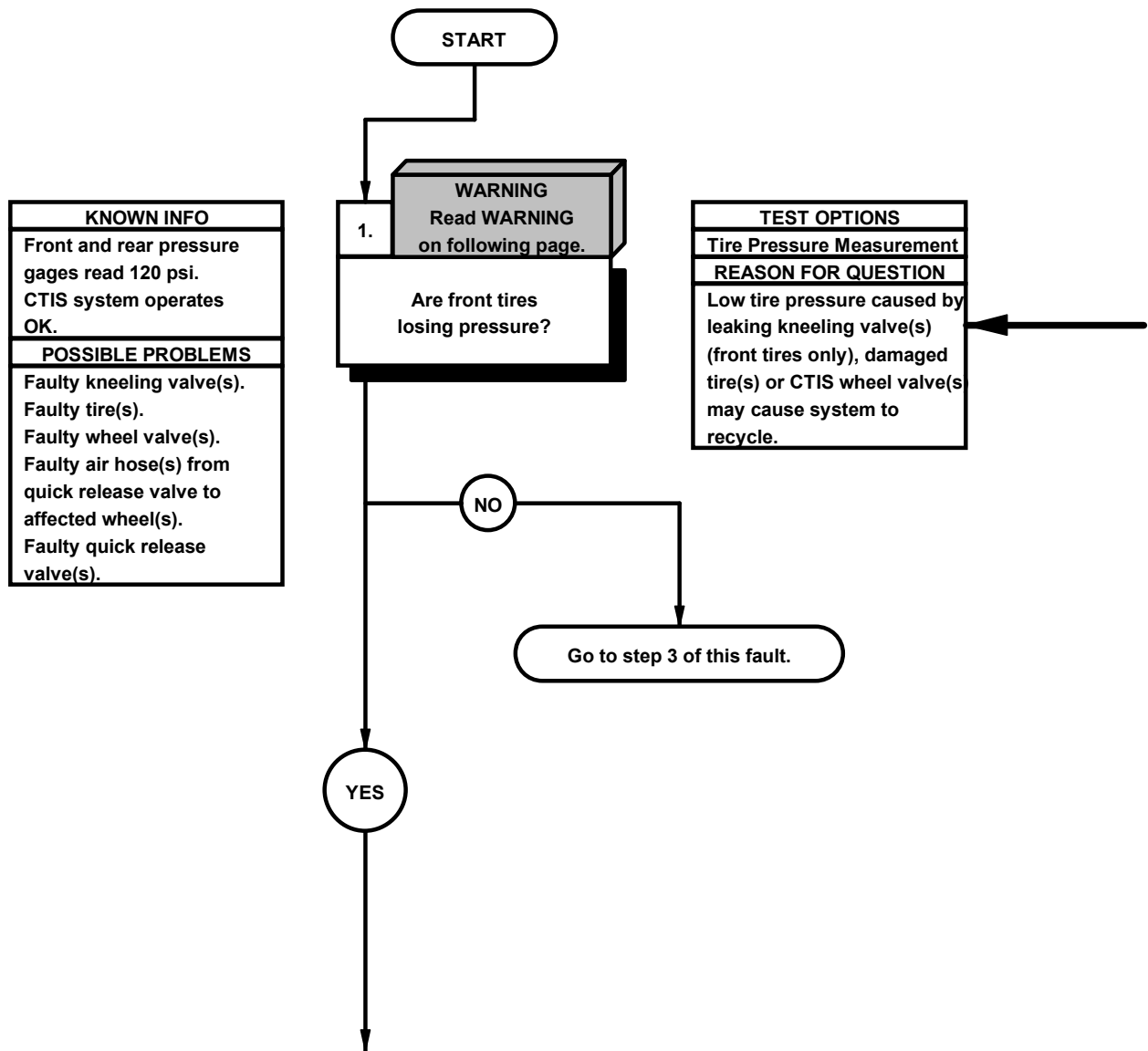

WARNING

Wear appropriate eye protection when working under vehicle and around CTIS system due to the possibility of falling and/or blown debris. Failure to comply may result in injury to personnel.

NOTE

CTIS ECU checks tire pressure 30 seconds after completing a pressure change sequence. If tire pressures are the same, system reverts to checking pressure every 15 minutes. If tires are losing pressure, ECU inflates tires and checks pressure again in 30 seconds. If CTIS has to repeat this process more than 10 times, ECU will display four flashing lights.

- (1) Measure and record the tire pressure of each tire (TM 9-2320-366-10-1).
- (2) If front tire(s) have lower pressure than the rest, kneeling valve, tire or CTIS wheel valve is faulty.
- (3) If rear tire(s) have lower pressure than the rest, tire or CTIS wheel valve is faulty.

m4. CENTRAL TIRE INFLATION SYSTEM (CTIS) REPEATEDLY RESUMES CYCLING 30 SECONDS AFTER INDICATOR LIGHTS STOP FLASHING (CONT)

KNOWN INFO
Front and rear pressure gages read 120 psi. CTIS system operates OK.
POSSIBLE PROBLEMS
Faulty kneeling valve(s). Faulty tire(s). Faulty wheel valve(s). Faulty air hose(s) from quick release valve to affected wheel(s). Faulty quick release valve(s).

2.
Is kneeling valve on affected wheel(s) free from leaks?

TEST OPTIONS
Soapy Water Leak Test
REASON FOR QUESTION
A leaking kneeling valve can cause tire to loose air pressure and CTIS system may repeat inflation sequence.

NO
Clean and tighten or replace kneeling valve (para 12-5).

YES

KNOWN INFO
Front and rear pressure gages read 120 psi. CTIS system operates OK. Kneeling valve(s) OK.
POSSIBLE PROBLEMS
Faulty tire(s). Faulty wheel valve(s). Faulty air hose(s) from quick release valve to affected wheel(s). Faulty quick release valve(s).

3.
Are tires free from leaks or damage?

TEST OPTIONS
Soapy Water Leak Test
REASON FOR QUESTION
A leaking tire can cause CTIS system to detect a pressure loss and repeat inflation sequence.

NO
Repair tire(s) (para 12-2) or replace tire(s) (TM 9-2320-366-10).

YES

SOAPY WATER LEAK TEST

- (1) Check kneeling valve is tight and secure in valve seat.
- (2) Apply soapy water to valve and check for leaks.

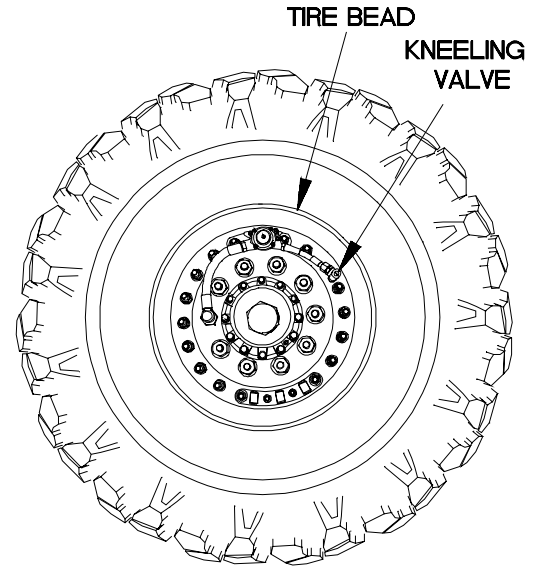

X2M0402-

SOAPY WATER LEAK TEST

- (1) Visually inspect tire for damage.
- (2) Apply soapy water solution to tire bead.
- (3) Observe tire for bubbles indicating leaks.

m4. CENTRAL TIRE INFLATION SYSTEM (CTIS) REPEATEDLY RESUMES CYCLING 30 SECONDS AFTER INDICATOR LIGHTS STOP FLASHING (CONT)

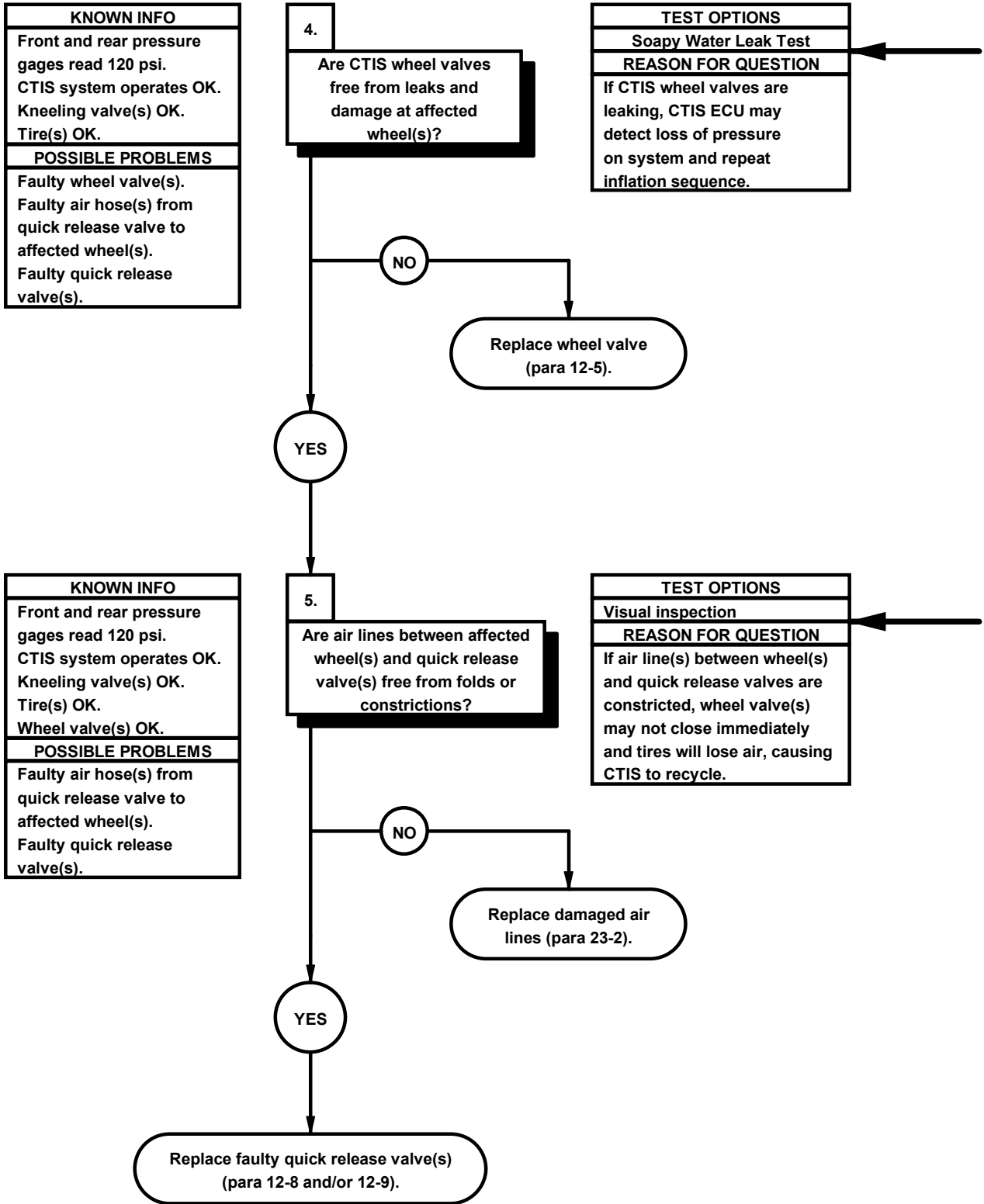

SOAPY WATER LEAK TEST

- (1) Apply soapy water solution to CTIS fittings on outside of wheel.
- (2) Observe fittings for bubbles indicating leaks.
- (3) With wheel valve still connected to tire, disconnect wheel valve air supply line from hub at banjo bolt.
- (4) Place open end of air supply line in container of water. Look for air bubbles.
- (5) Persistent bubbles from air line indicate faulty wheel valve.
- (6) Connect wheel valve to hub at banjo bolt.

NOTE

If air line from quick release valve to affected wheel is partially obstructed, air line to wheel cannot escape back to quick release valve immediately after tire is pressurized causing wheel valve to remain partially open and tire to lose pressure. System will cycle again when low pressure is checked after 30 seconds.

- (1) Check air supply line(s) from quick release valve(s) to affected wheel(s) for constrictions. See illustration for fitting and quick release valve locations.
- (2) If air supply line is not constricted, quick release valve for affected wheel is faulty.

WHEEL VALVE

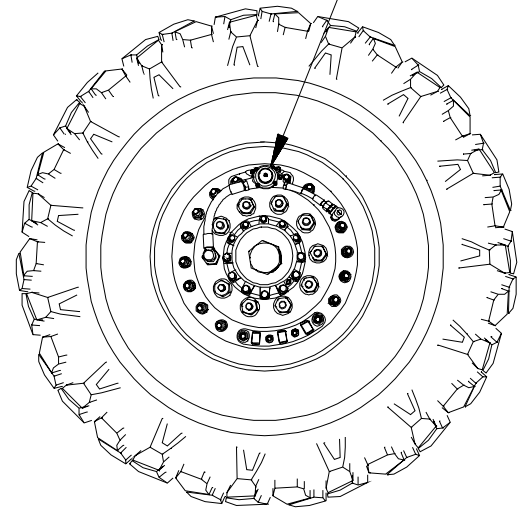

X2M0404-

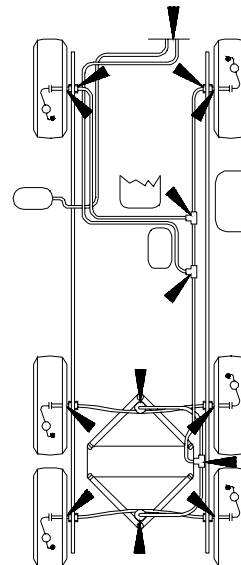

**AIR HOSE FITTINGS
WHEELS TO QUICK
RELEASE VALVES**

X2M0405-

m5. CENTRAL TIRE INFLATION SYSTEM (CTIS) ECU INDICATES NO FAULT CODE BUT SYSTEM FAILS TO INFLATE OR DEFLATE

INITIAL SETUP

Equipment Conditions

Engine shut down (TM 9-2320-366-10-1).

Materials/Parts

Soap, Laundry (Item 63, Appendix D)

Tools and Special Tools

Tool Kit, Genl Mech (Item 46, Appendix C)

Pan, Wash (Item 25, Appendix C)

Goggles, Industrial (Item 15, Appendix C)

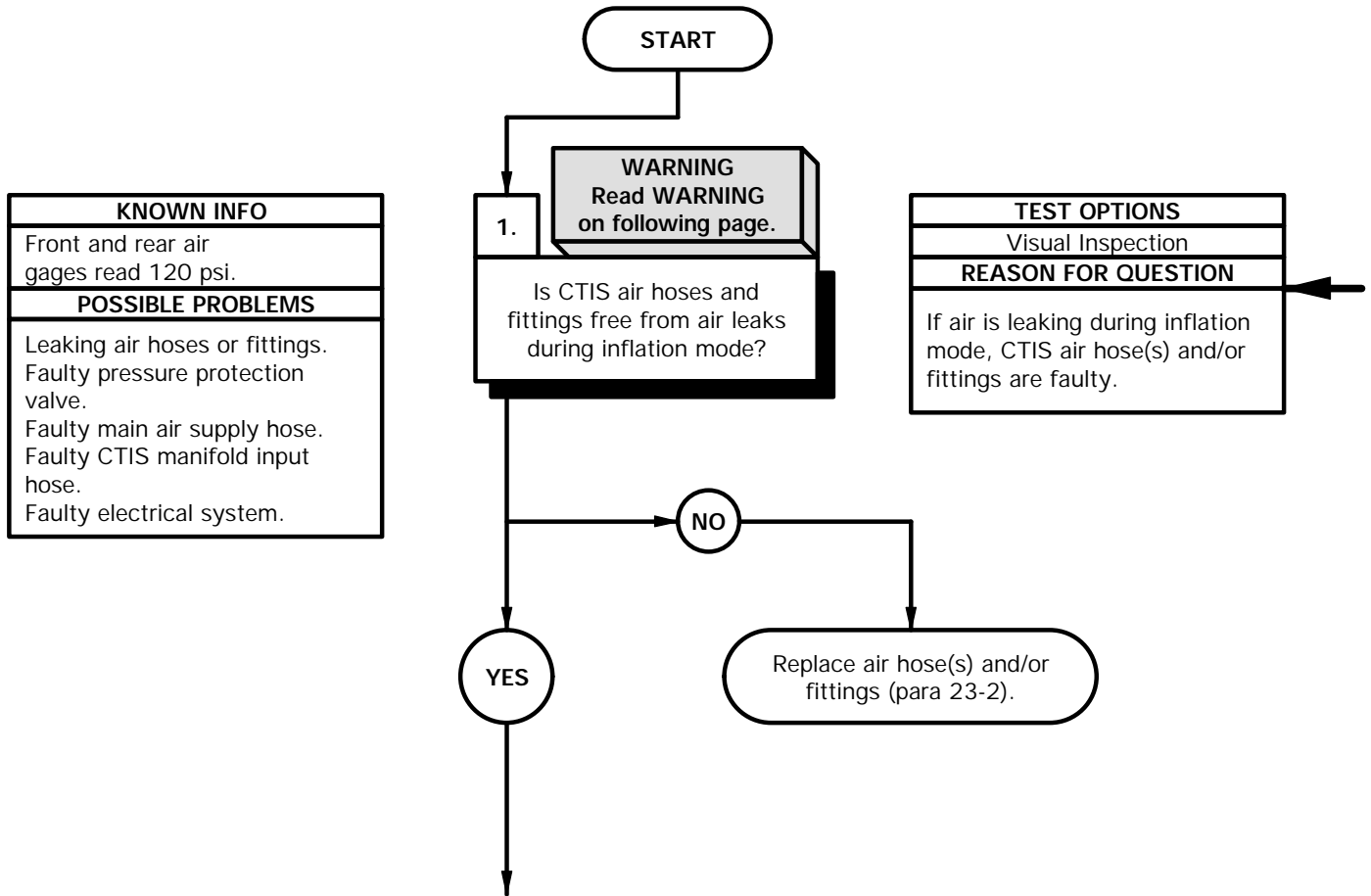

WARNING

Wear appropriate eye protection when working under vehicle due to the possibility of falling debris. Failure to comply may result in injury to personnel.

- (1) Start engine (TM 9-2320-366-10-1).
- (2) Set CTIS ECU to RUN FLAT mode (TM 9-2320-366-10-1).
- (3) Apply soapy water solution to CTIS air hoses and fittings (Table 23-2 Central Tire Inflation System (CTIS) Air Hose Locations).
- (4) Check for soap bubbles indicating leaks.
- (5) If any leaks are found, replace CTIS air hose and/or fittings (para 23-2).
- (6) Shut down engine (TM 9-2320-366-10-1).

m5. CENTRAL TIRE INFLATION SYSTEM (CTIS) ECU INDICATES NO FAULT CODE BUT SYSTEM FAILS TO INFLATE OR DEFLATE (CONT)

KNOWN INFO
Front and rear air gages read 120 psi.
POSSIBLE PROBLEMS
Leaking air hoses or fittings. Faulty pressure protection valve. Faulty main air supply hose. Faulty CTIS manifold input hose. Faulty electrical system.

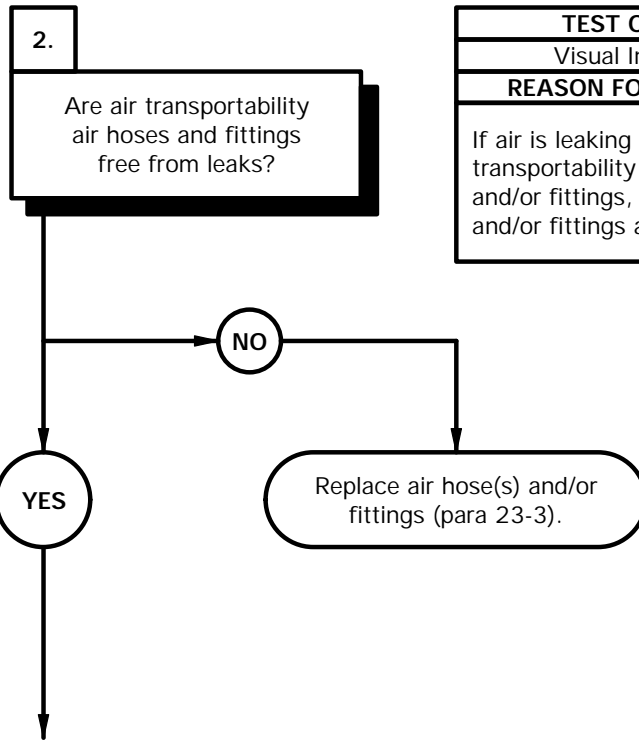

TEST OPTIONS
Visual Inspection
REASON FOR QUESTION
If air is leaking from air transportability air hose(s) and/or fittings, air hose(s) and/or fittings are faulty.

- (1) Start engine (TM 9-2320-366-10-1).
- (2) Apply soapy water solution to air transportability air hoses and fittings (Table 23-3. Air Transportability Air Hose Locations).
- (3) Check for soap bubbles indicating leaks.
- (4) If any leaks are found, replace air transportability air hose and/or fittings (para 23-3).
- (5) Shut down engine (TM 9-2320-366-10-1).

m5. CENTRAL TIRE INFLATION SYSTEM (CTIS) ECU INDICATES NO FAULT CODE BUT SYSTEM FAILS TO INFLATE OR DEFLATE (CONT)

KNOWN INFO
Front and rear air gages read 120 psi. Air hoses and fittings free from leaks.
POSSIBLE PROBLEMS
Faulty pressure protection valve. Faulty main air supply hose. Faulty CTIS manifold input hose. Faulty electrical system.

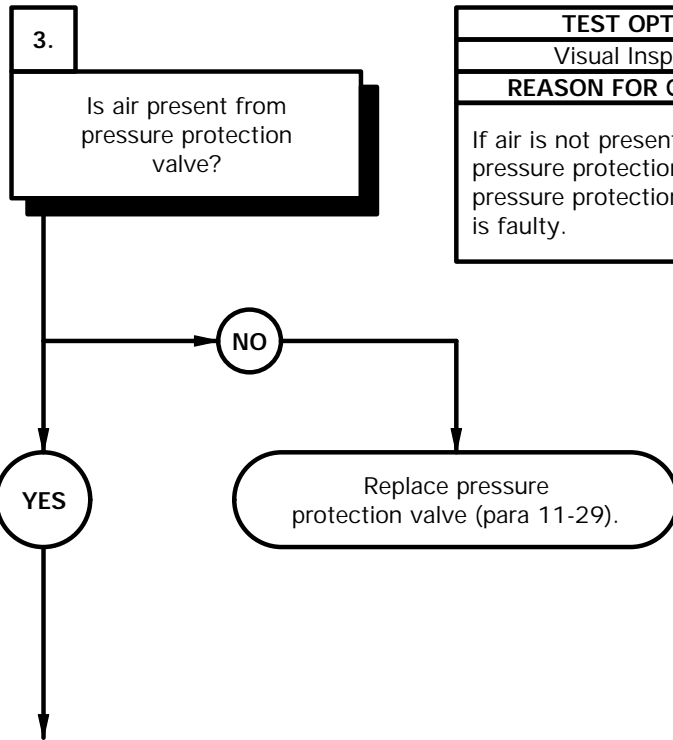

TEST OPTIONS
Visual Inspection
REASON FOR QUESTION
If air is not present from pressure protection valve, pressure protection valve is faulty.

- (1) Disconnect main air supply hose from pressure protection valve.
- (2) Start engine (TM 9-2320-366-10-1).
- (3) If air is not present from pressure protection valve, replace pressure protection valve (para 11-29).
- (4) Shut down engine (TM 9-2320-366-10-1).
- (5) Connect main air supply hose to pressure protection valve.

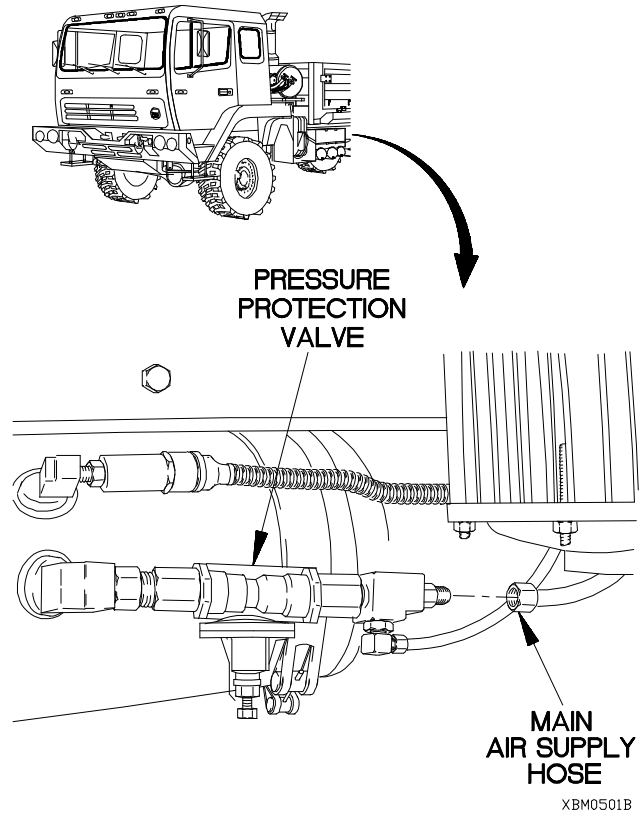

XBM0501B

m5. CENTRAL TIRE INFLATION SYSTEM (CTIS) ECU INDICATES NO FAULT CODE BUT SYSTEM FAILS TO INFLATE OR DEFLATE (CONT)

KNOWN INFO
Front and rear air gages read 120 psi. Air hoses and fittings free from leaks. Pressure protection valve OK.
POSSIBLE PROBLEMS
Faulty main air supply hose. Faulty CTIS manifold input hose. Faulty electrical system.

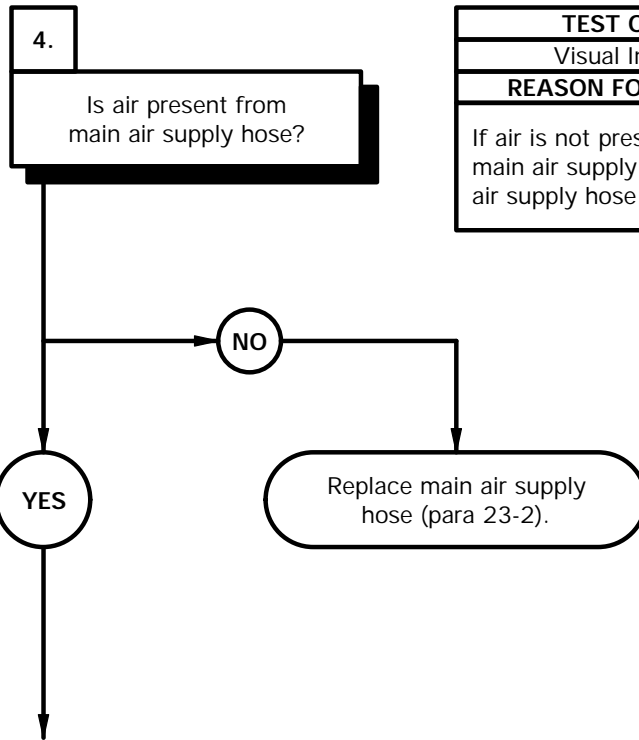

TEST OPTIONS
Visual Inspection
REASON FOR QUESTION
If air is not present from main air supply hose, main air supply hose is faulty.



- (1) Remove kick panel (para 16-3).
- (2) Disconnect CTIS manifold input hose from cab bulkhead fitting.
- (3) Start engine (TM 9-2320-366-10-1).
- (4) If air is not present from cab bulkhead fitting, replace main air supply hose (para 23-2).
- (5) Shut down engine (TM 9-2320-366-10-1).
- (6) Connect CTIS manifold input hose to cab bulkhead fitting.

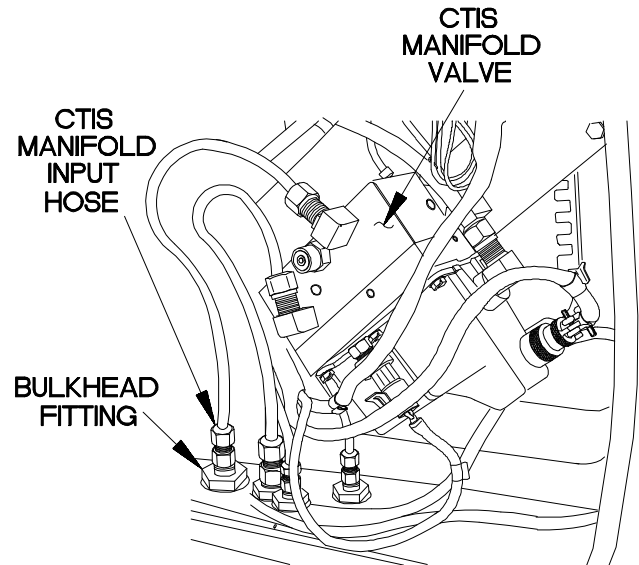

Xbm0502b

m5. CENTRAL TIRE INFLATION SYSTEM (CTIS) ECU INDICATES NO FAULT CODE BUT SYSTEM FAILS TO INFLATE OR DEFLATE (CONT)

KNOWN INFO
Front and rear air gages read 120 psi. Air hoses and fittings free from leaks. Pressure protection valve OK. Main air supply hose OK.
POSSIBLE PROBLEMS
Faulty CTIS manifold input hose. Faulty electrical system.

5.
Is air present from CTIS manifold input hose?

TEST OPTIONS
Visual Inspection
REASON FOR QUESTION
If air is not present from CTIS manifold input hose, CTIS manifold input hose is faulty.

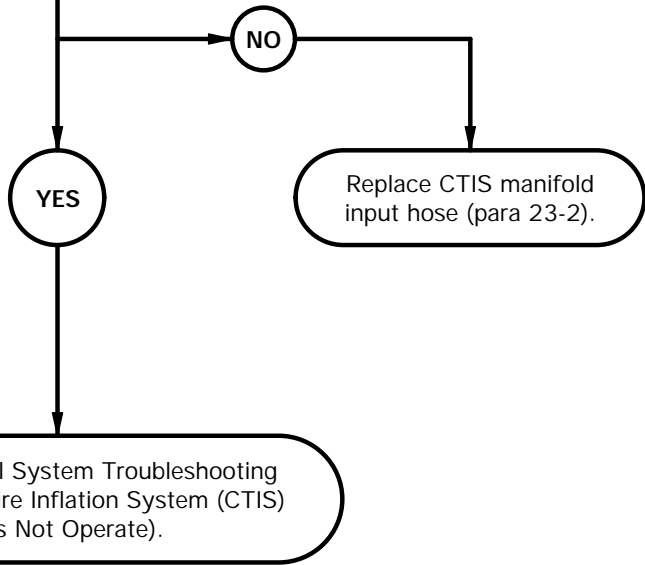

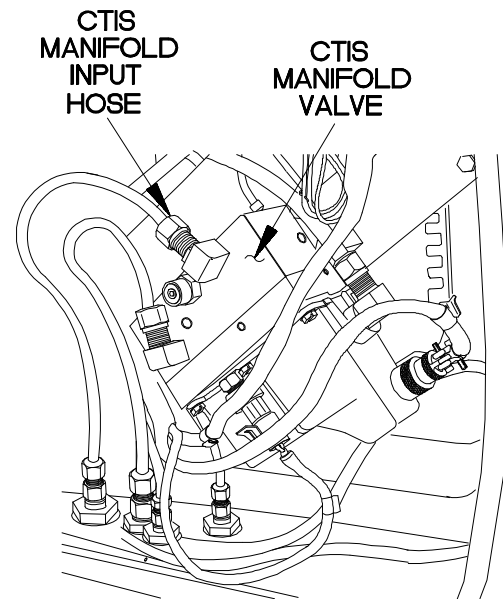

- (1) Disconnect CTIS manifold input hose from CTIS manifold valve.
- (2) Start engine (TM 9-2320-366-10-1).
- (3) If air is not present from CTIS manifold input hose, replace CTIS manifold input hose (para 23-2).
- (4) If air is present from CTIS manifold input hose go to Electrical Troubleshooting (e85. Central Tire Inflation System (CTIS) Does Not Operate).
- (5) Shut down engine (TM 9-2320-366-10-1).
- (6) Connect CTIS manifold input hose to CTIS manifold valve.
- (7) Install kick panel (para 16-3).

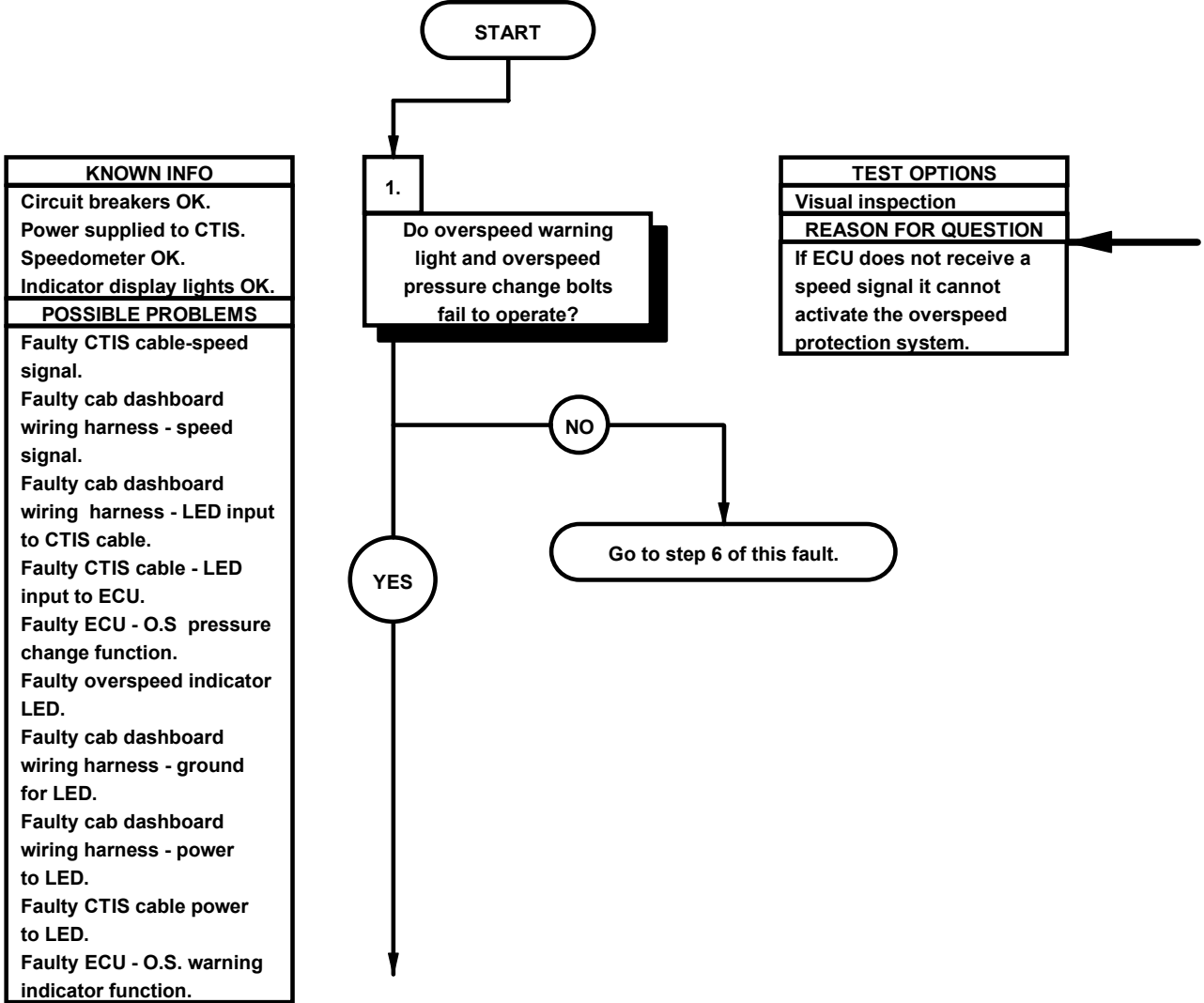

XBM0503B

m6. CTIS OVERSPEED WARNING LIGHT DOES NOT ILLUMINATE AND/OR OVERSPEED PRESSURE CHANGE	
INITIAL SETUP	
Equipment Conditions Engine running (TM 9-2320-366-10-1).	Tools and Special Tools Tool Kit, Genl Mech (Item 46, Appendix C) Multimeter, Digital (Item 22, Appendix C) Wrench, Torque, 0-200 lb-in. (Item 59, Appendix C) Wrench, Torque, 0-75 lb-in. (Item 90, Appendix B) STE/ICE-R (Item 41, Appendix C)
Personnel Required (2)	
References TM 9-4910-571-12&P	



- 
- (1) Select X-C mode at CTIS ECU
(TM 9-2320-366-10-1).
 - (2) Turn on headlights (TM 9-2320-366-10-1).
 - (3) Perform road test.
 - (4) Increase speed to 40 mph.
 - (5) Check if overspeed warning light flashes.
 - (6) After about one minute, check if overspeed pressure change is activated to raise tire pressure to HWY mode.
 - (7) If both functions fail to activate, speed signal to ECU is faulty or ECU may be faulty.
 - (8) Shut down engine (TM 9-2320-366-10-1).

m6. CTIS OVERSPEED WARNING LIGHT DOES NOT ILLUMINATE AND/OR OVERSPEED PRESSURE CHANGE (CONT)

KNOWN INFO
Circuit breakers OK. Power supplied to CTIS. Speedometer OK. Indicator display lights OK.
POSSIBLE PROBLEMS
Faulty CTIS cable-speed signal. Faulty cab dashboard wiring harness - speed signal. Faulty cab dashboard wiring harness - LED input to CTIS cable. Faulty CTIS cable - LED input to ECU. Faulty ECU - O.S pressure change function. Faulty overspeed indicator LED. Faulty cab dashboard wiring harness - ground for LED. Faulty cab dashboard wiring harness - power to LED. Faulty CTIS cable power to LED. Faulty ECU - O.S. warning indicator function.

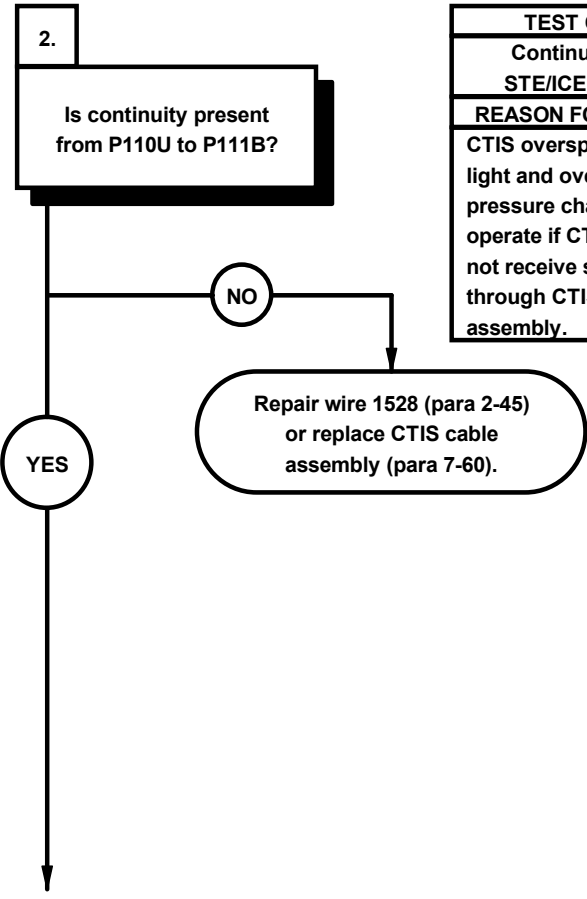

TEST OPTIONS
Continuity Test or STE/ICE-R Test #91
REASON FOR QUESTION
CTIS overspeed warning light and overspeed pressure change will not operate if CTIS ECU does not receive speed signal through CTIS cable assembly.



CONTINUITY TEST

- (1) Remove kick panel (para 16-3).
- (2) Disconnect connector P110 from CTIS ECU.
- (3) Disconnect connector P111 from connector J111.
- (4) Set multimeter to ohms.
- (5) Connect positive (+) probe of multimeter to connector P110U.
- (6) Connect negative (-) probe of multimeter to connector P111B and note reading on multimeter.
- (7) If continuity is not present, repair wire 1528 (para 2-45) or replace CTIS cable assembly (para 7-60).

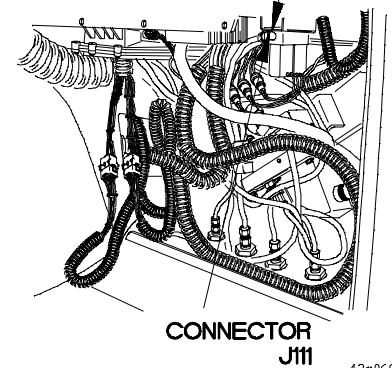
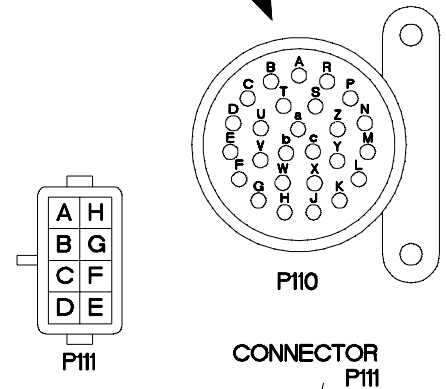
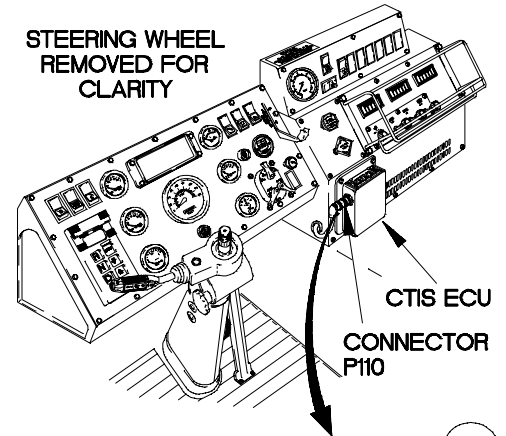

42#06011

m6. CTIS OVERSPEED WARNING LIGHT DOES NOT ILLUMINATE AND/OR OVERSPEED PRESSURE CHANGE (CONT)

KNOWN INFO
Circuit breakers OK. Power supplied to CTIS. Speedometer OK. Indicator display lights OK. CTIS cable-speed signal OK.
POSSIBLE PROBLEMS
Faulty cab dashboard wiring harness - speed signal. Faulty cab dashboard wiring harness - LED input to CTIS cable. Faulty CTIS cable - LED input to ECU. Faulty ECU - O.S pressure change function. Faulty overspeed indicator LED. Faulty cab dashboard wiring harness - ground for LED. Faulty cab dashboard wiring harness - power to LED. Faulty CTIS cable power to LED. Faulty ECU - O.S. warning indicator function.

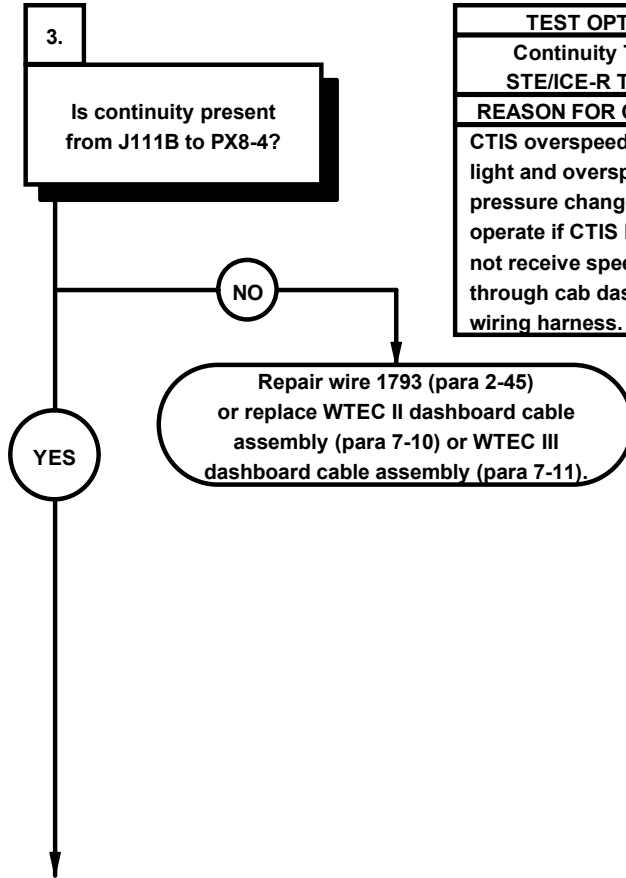

TEST OPTIONS
Continuity Test or STE/ICE-R Test #91
REASON FOR QUESTION
CTIS overspeed warning light and overspeed pressure change will not operate if CTIS ECU does not receive speed signal through cab dashboard wiring harness.



CONTINUITY TEST

- (1) Remove instrument panel assembly for access (para 7-15).
- (2) Disconnect connector clamp from speedometer connector.
- (3) Disconnect connector PX8 from speedometer.
- (4) Set multimeter to ohms position.
- (5) Connect positive (+) probe of multimeter to connector J111B.
- (6) Connect negative (-) probe of multimeter to connector PX8-4 and note reading on multimeter.
- (7) If continuity is not present, repair wire 1793 (para 2-45) or replace WTEC II dashboard cable assembly (para 7-10) or WTEC III dashboard cable assembly (para 7-11).
- (8) Connect connector PX8 to speedometer.
- (9) Connect connector clamp to speedometer connector.
- (10) Install instrument panel assembly (para 7-15).

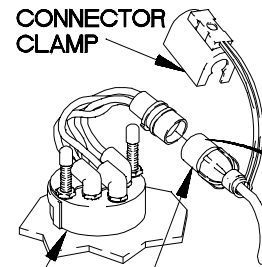
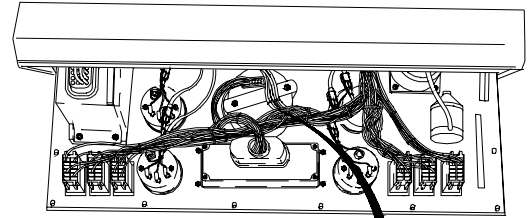

SPEEDOMETER

CONNECTOR
PX8

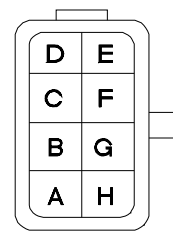

J111

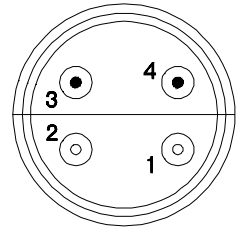

PX8

X2M0602A

m6. CTIS OVERSPEED WARNING LIGHT DOES NOT ILLUMINATE AND/OR OVERSPEED PRESSURE CHANGE (CONT)

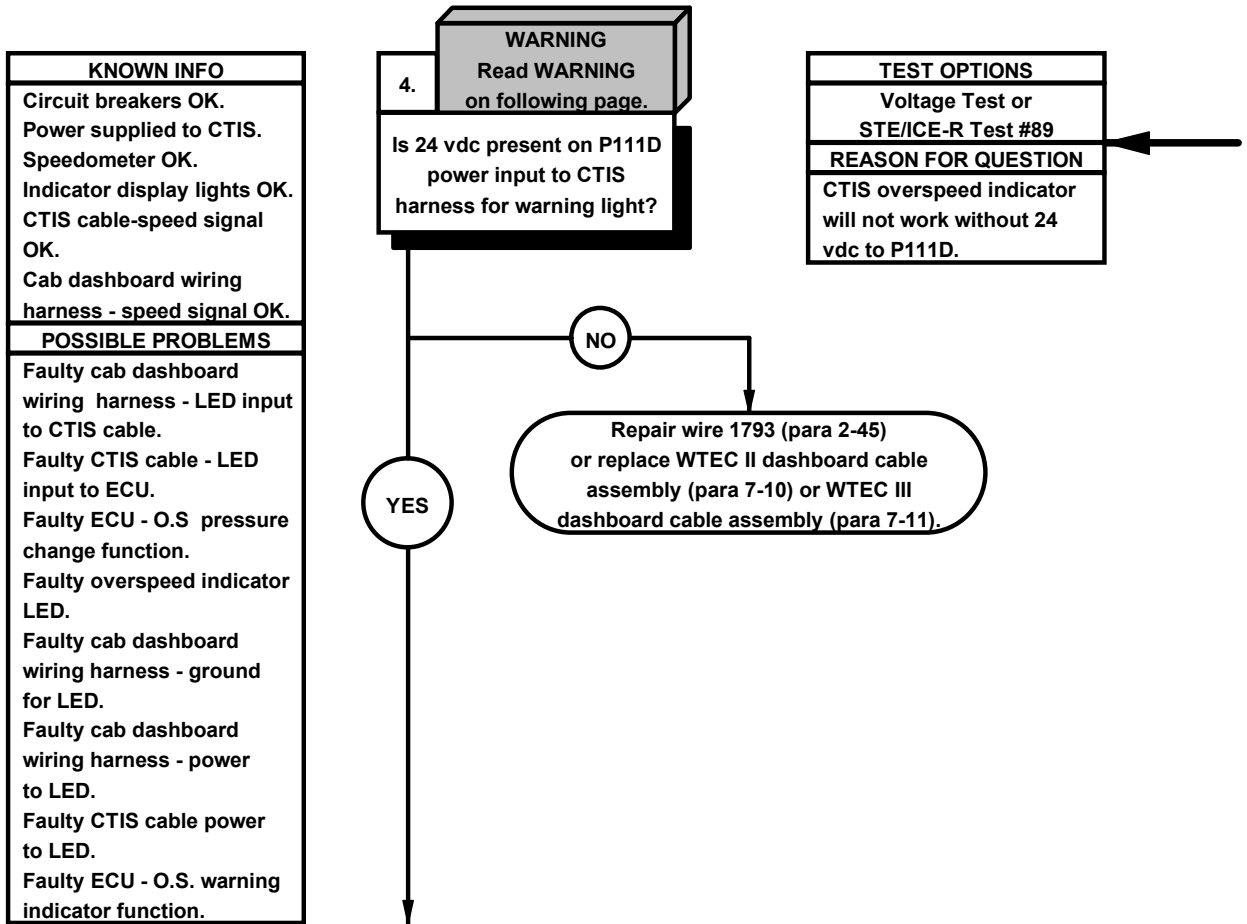

WARNING

Remove rings, bracelets, watches, necklaces, and any other jewelry before working around vehicle. Jewelry can catch on equipment and cause injury or short across electrical circuit and cause severe burns or electrical shock.

VOLTAGE TEST

- (1) Position master power switch to on (TM 9-2320-366-10-1).
- (2) Connect positive (+) probe of multimeter to connector P111D.
- (3) Connect negative (-) probe of multimeter to ground and note reading on multimeter.
- (4) If 24 vdc is not present, repair wire 1793 (para 2-45) or replace WTEC II dashboard cable assembly (para 7-10) or WTEC III dashboard cable assembly (para 7-11).
- (5) Position master power switch to off (TM 9-2320-366-10-1).
- (6) Connect connector P111 to connector J111.

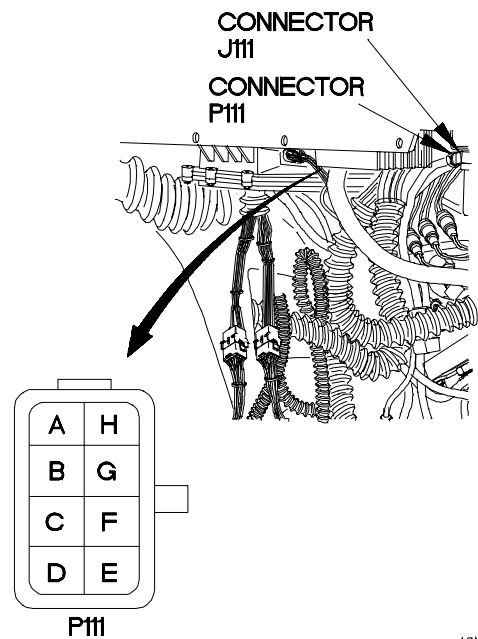

42M0603A

m6. CTIS OVERSPEED WARNING LIGHT DOES NOT ILLUMINATE AND/OR OVERSPEED PRESSURE CHANGE (CONT)

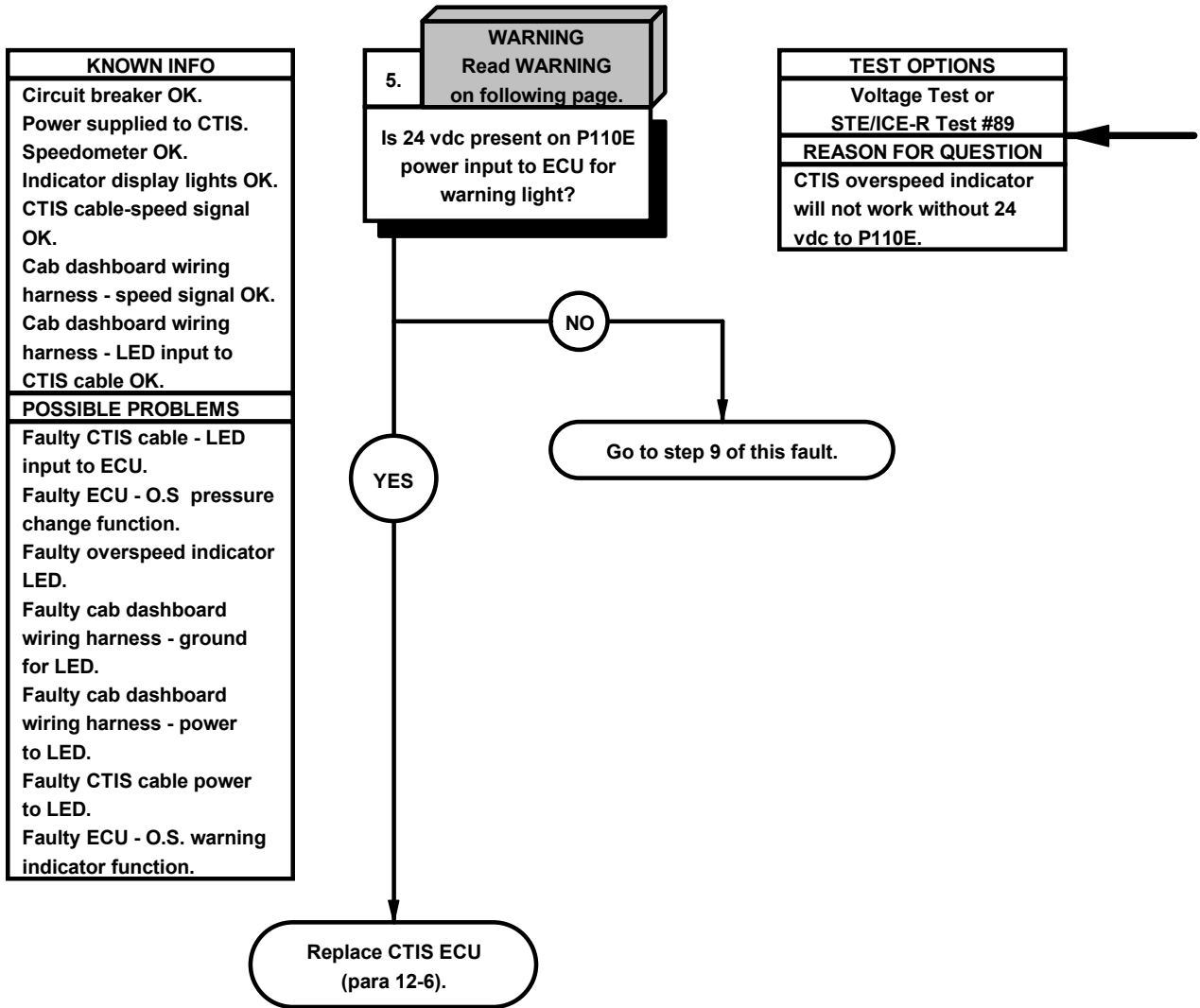

WARNING

Remove rings, bracelets, watches, necklaces, and any other jewelry before working around vehicle. Jewelry can catch on equipment and cause injury or short across electrical circuit and cause severe burns or electrical shock.

VOLTAGE TEST

- (1) Position master power switch to on (TM 9-2320-366-10-1).
- (2) Connect positive (+) probe of multimeter to connector P110E.
- (3) Connect negative (-) probe of multimeter to ground and note reading on multimeter.
- (4) If 24 vdc is not present, CTIS wiring harness is faulty.
- (5) If 24 vdc is present, replace CTIS ECU (para 12-6).
- (6) Position master power switch to off (TM 9-2320-366-10-1).
- (7) Connect connector P110 to CTIS ECU.

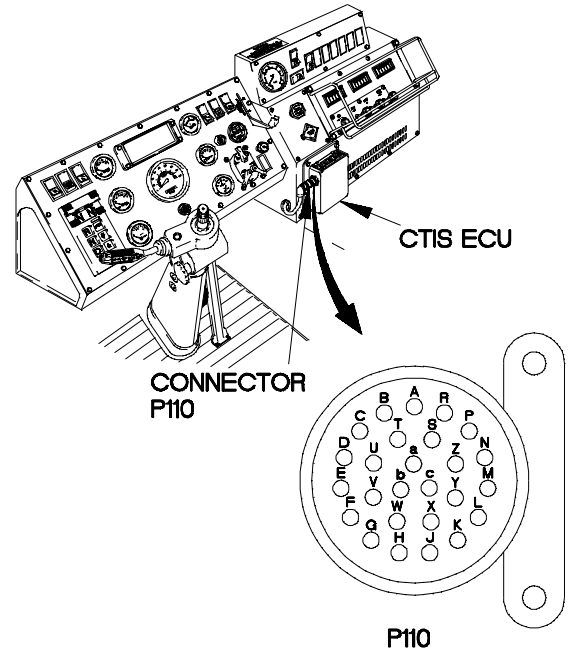

X2M0604A

m6. CTIS OVERSPEED WARNING LIGHT DOES NOT ILLUMINATE AND/OR OVERSPEED PRESSURE CHANGE (CONT)

KNOWN INFO
Circuit breaker OK. Power supplied to CTIS. Speedometer OK. Indicator display lights OK. CTIS cable-speed signal OK. Cab dashboard wiring harness - speed signal OK. Cab dashboard wiring harness - LED input to CTIS cable OK. CTIS cable - LED input to ECU OK.
POSSIBLE PROBLEMS
Faulty ECU - O.S pressure change function. Faulty overspeed indicator LED. Faulty cab dashboard wiring harness - ground for LED. Faulty cab dashboard wiring harness - power to LED. Faulty CTIS cable power to LED. Faulty ECU - O.S. warning indicator function.

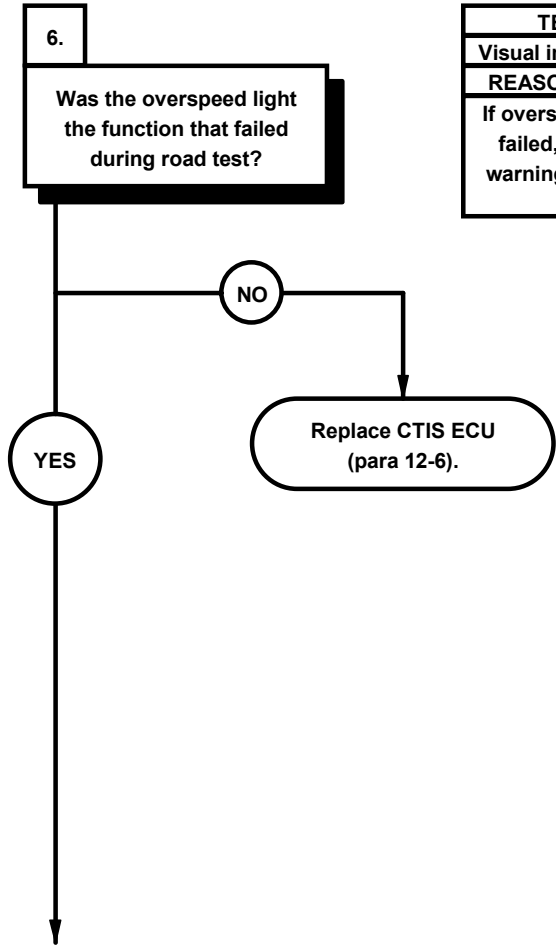

TEST OPTIONS
Visual inspection
REASON FOR QUESTION
If overspeed warning light failed, warning lamp or warning lamp circuit may be faulty.



- 
- (1) If overspeed warning light failed on road test while overspeed pressure change occurred;
 - (a) Warning lamp may be faulty.
 - (b) Wiring from ECU to lamp or lamp to ground may be faulty.
 - (c) ECU may be faulty.
 - (2) If overspeed warning light flashed on road test while overspeed pressure change did not occur, ECU has received a good speed signal but has not translated the signal into an overspeed inflation, replace CTIS ECU (para 12-6).

m6. CTIS OVERSPEED WARNING LIGHT DOES NOT ILLUMINATE AND/OR OVERSPEED PRESSURE CHANGE (CONT)

KNOWN INFO
Circuit breaker OK. Power supplied to CTIS. Speedometer OK. Indicator display lights OK. CTIS cable-speed signal OK. Cab dashboard wiring harness - speed signal OK. Cab dashboard wiring harness - LED input to CTIS cable OK. CTIS cable - LED input to ECU OK. ECU - O.S. pressure change function OK.
POSSIBLE PROBLEMS
Faulty overspeed indicator LED. Faulty cab dashboard wiring harness - ground for LED. Faulty cab dashboard wiring harness - power to LED. Faulty CTIS cable power to LED. Faulty ECU - O.S. warning indicator function.

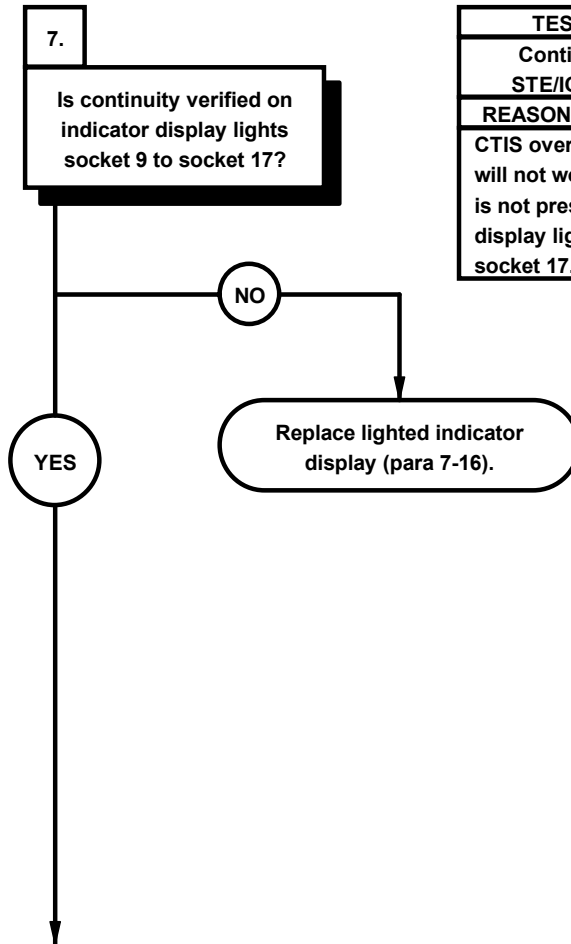

TEST OPTIONS
Continuity Test or STE/ICE-R Test #91
REASON FOR QUESTION
CTIS overspeed indicator will not work if continuity is not present from indicator display lights socket 9 to socket 17.



CONTINUITY TEST

- (1) Remove four screws from lighted indicator display.
- (2) Remove lighted indicator display from instrument panel assembly.
- (3) Disconnect connector PX7 from lighted indicator display.
- (4) Set multimeter to ohms.
- (5) Connect positive (+) probe of multimeter to lighted indicator display terminal 17.
- (6) Connect negative (-) probe of multimeter to lighted indicator terminal 9 and note reading on multimeter.
- (7) If continuity is not present, replace lighted indicator display (para 7-16).

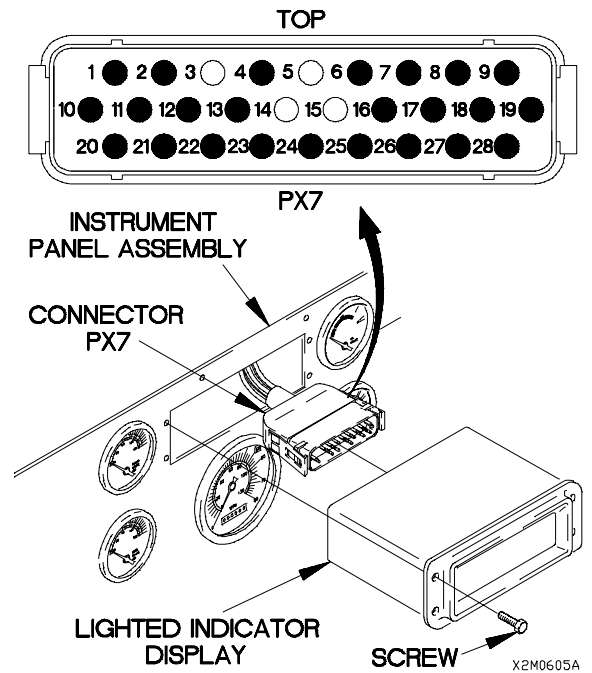

m6. CTIS OVERSPEED WARNING LIGHT DOES NOT ILLUMINATE AND/OR OVERSPEED PRESSURE CHANGE (CONT)

KNOWN INFO
Circuit breaker OK. Power supplied to CTIS. Speedometer OK. Indicator display lights OK. CTIS cable-speed signal OK. Cab dashboard wiring harness - speed signal OK. Cab dashboard wiring harness - LED input to CTIS cable OK. CTIS cable - LED input to ECU OK. ECU - O.S. pressure change function OK. Overspeed indicator LED OK.
POSSIBLE PROBLEMS
Faulty cab dashboard wiring harness - ground for LED. Faulty cab dashboard wiring harness - power to LED. Faulty CTIS cable power to LED. Faulty ECU - O.S. warning indicator function.

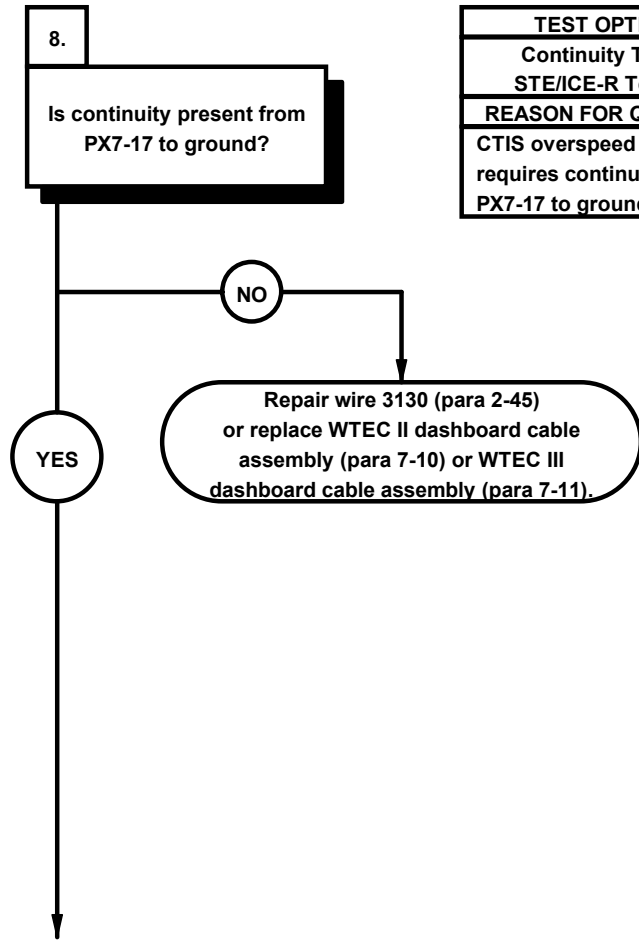

TEST OPTIONS
Continuity Test or STE/ICE-R Test #91
REASON FOR QUESTION
CTIS overspeed indicator requires continuity from PX7-17 to ground.



CONTINUITY TEST

- (1) Set multimeter to ohms.
- (2) Connect positive (+) probe of multimeter to connector PX7-17.
- (3) Connect negative (-) probe of multimeter to ground and note reading on multimeter.
- (4) If continuity is not present, repair wire 3130 (para 2-45) or replace WTEC II dashboard cable assembly (para 7-10) or WTEC III dashboard cable assembly (para 7-11).

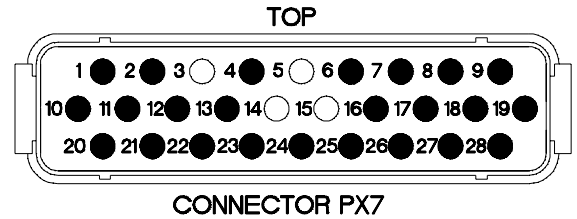

X2M0606A

m6. CTIS OVERSPEED WARNING LIGHT DOES NOT ILLUMINATE AND/OR OVERSPEED PRESSURE CHANGE (CONT)

KNOWN INFO
Circuit breaker OK.
Power supplied to CTIS.
Speedometer OK.
Indicator display lights OK.
CTIS cable-speed signal OK.
Cab dashboard wiring harness - speed signal OK.
Cab dashboard wiring harness - LED input to CTIS cable OK.
CTIS cable - LED input to ECU OK.
ECU - O.S. pressure change function OK.
Overspeed indicator LED OK.
Cab dashboard wiring harness - ground for LED OK.
POSSIBLE PROBLEMS
Faulty cab dashboard wiring harness - power to LED.
Faulty CTIS cable power to LED.
Faulty ECU - O.S. warning indicator function.

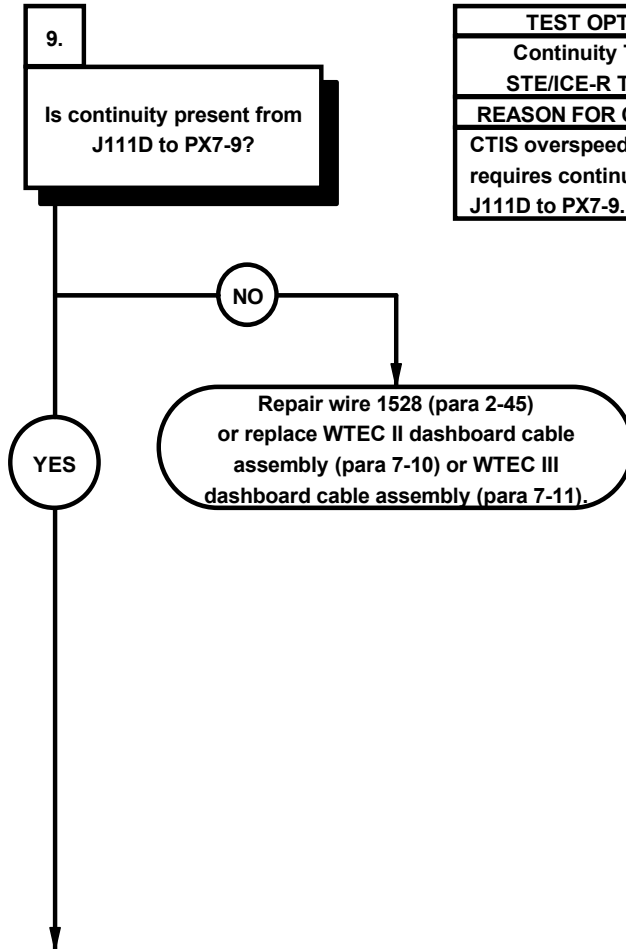

TEST OPTIONS
Continuity Test or STE/ICE-R Test #91
REASON FOR QUESTION
CTIS overspeed indicator requires continuity from J111D to PX7-9.



- | CONTINUITY TEST | |
|-----------------|--|
| (1) | Set multimeter to ohms. |
| (2) | Connect positive (+) probe of multimeter to connector PX7-9. |
| (3) | Connect negative (-) probe of multimeter to connector J111D and note reading on multimeter. |
| (4) | If continuity is not present, repair wire 1528 (para 2-45) or replace WTEC II dashboard cable assembly (para 7-10) or WTEC III dashboard cable assembly (para 7-11). |
| (5) | Connect lighted indicator display to connector PX7. |
| (6) | Position lighted indicator display in instrument panel assembly with four screws. |
| (7) | Tighten four screws to 6-10 lb-in. (1 N·m). |

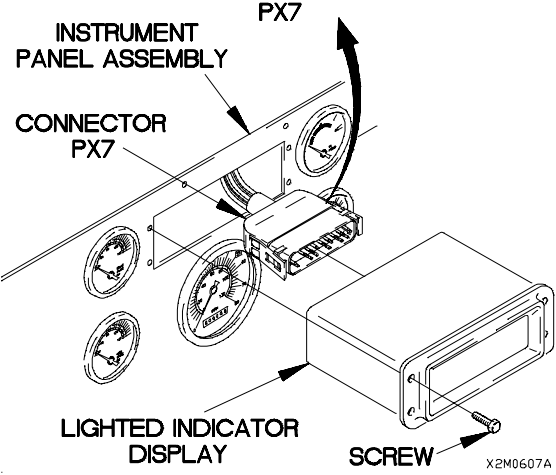
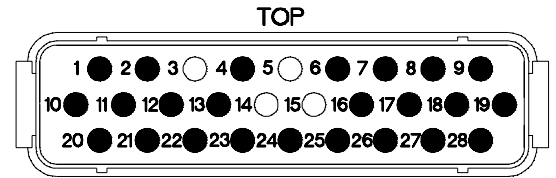
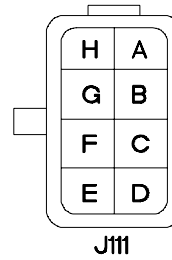

m6. CTIS OVERSPEED WARNING LIGHT DOES NOT ILLUMINATE AND/OR OVERSPEED PRESSURE CHANGE (CONT)

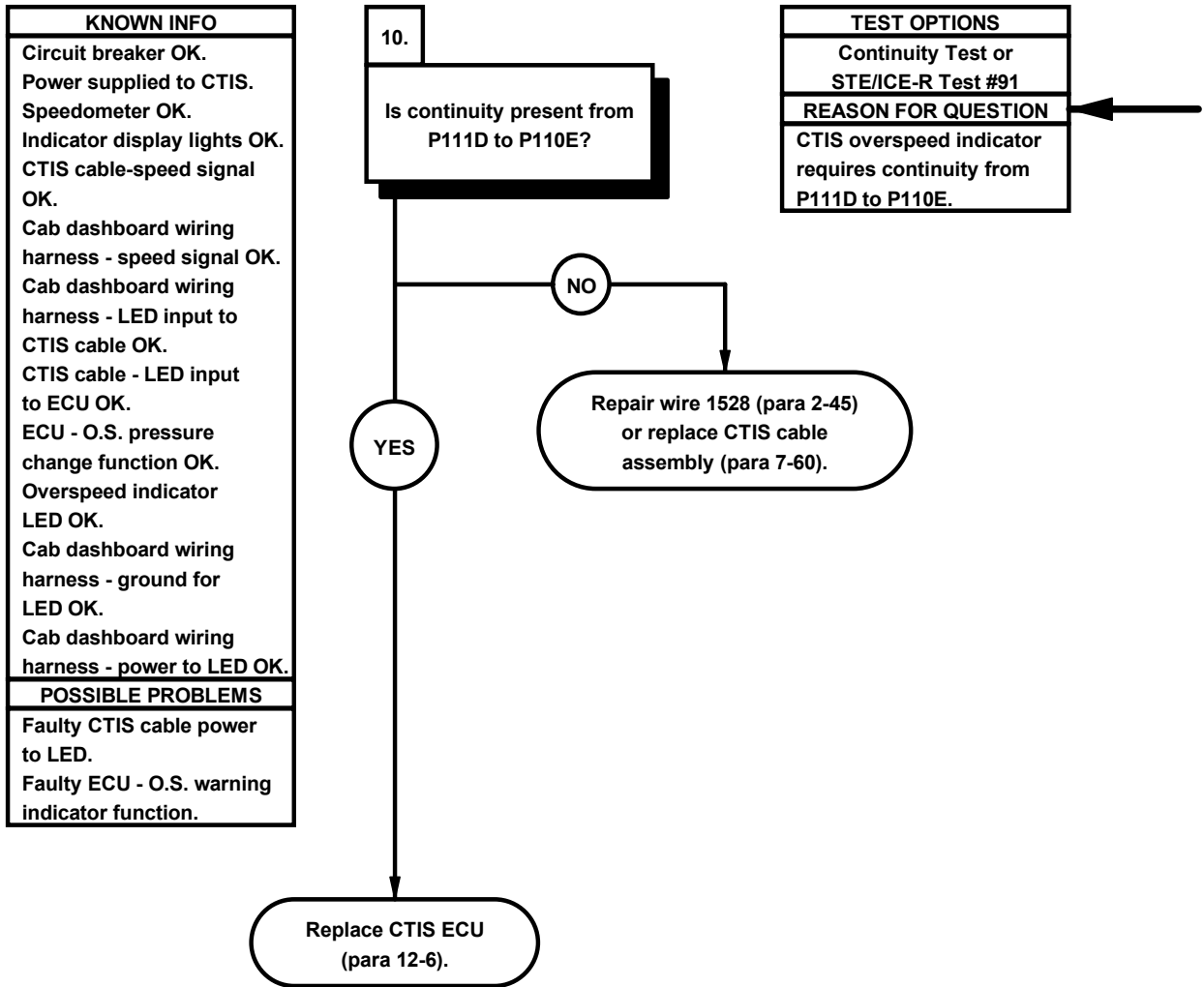

CONTINUITY TEST

- (1) Disconnect connector P110 from CTIS ECU.
- (2) Set multimeter to ohms.
- (3) Connect positive (+) probe of multimeter to connector P111D.
- (4) Connect negative (-) probe of multimeter to connector P110E and note reading on multimeter.
- (5) If continuity is not present, repair wire 1528 (para 2-45) or replace CTIS cable assembly (para 7-60).
- (6) If continuity is present, replace CTIS ECU (para 12-6).
- (7) Connect connector P110 to CTIS ECU.
- (8) Connect connector P111 to connector J111.
- (9) Install kick panel (para 16-3).

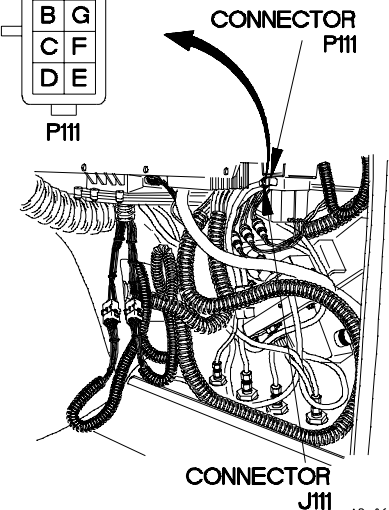
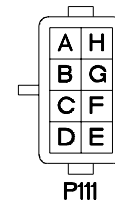
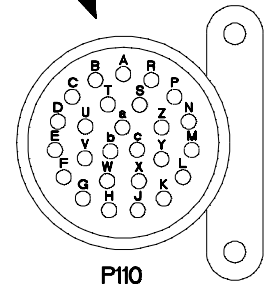
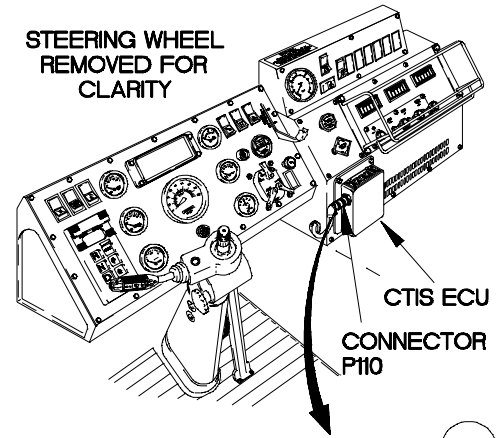

42m06081

2-25. AXLE TROUBLESHOOTING

This paragraph covers Axle Troubleshooting. The Axle Fault Index, Table 2-53, lists faults for the axles of the vehicle.

Table 2-53. Axle Fault Index

Fault No.	Description	Page
n1.	Axle Differential(s) Noisy	2-2144

n1. AXLE DIFFERENTIAL(S) NOISY	
INITIAL SETUP	
Equipment Conditions Engine shut down (TM 9-2320-366-10-1).	Tools and Special Tools Tool Kit, Genl Mech (Item 46, Appendix C)

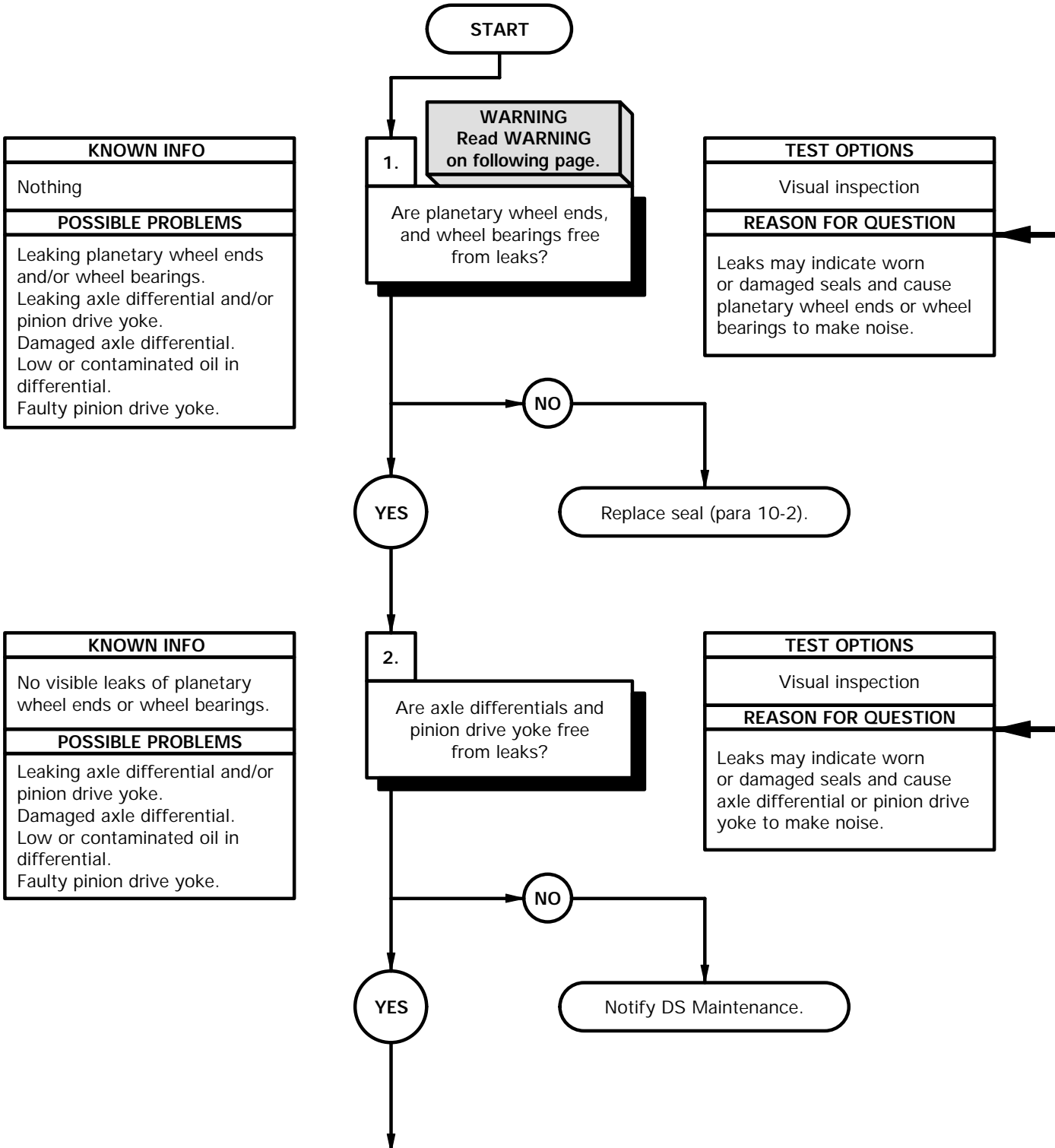

KNOWN INFO
Nothing
POSSIBLE PROBLEMS
Leaking planetary wheel ends and/or wheel bearings. Leaking axle differential and/or pinion drive yoke. Damaged axle differential. Low or contaminated oil in differential. Faulty pinion drive yoke.

TEST OPTIONS
Visual inspection
REASON FOR QUESTION
Leaks may indicate worn or damaged seals and cause planetary wheel ends or wheel bearings to make noise.

KNOWN INFO
No visible leaks of planetary wheel ends or wheel bearings.
POSSIBLE PROBLEMS
Leaking axle differential and/or pinion drive yoke. Damaged axle differential. Low or contaminated oil in differential. Faulty pinion drive yoke.

TEST OPTIONS
Visual inspection
REASON FOR QUESTION
Leaks may indicate worn or damaged seals and cause axle differential or pinion drive yoke to make noise.

WARNING

Wear appropriate eye protection when working under vehicle due to the possibility of falling debris. Failure to comply may result in injury to personnel.

- (1) Check planetary wheel ends for leaks (para 10-2).
- (2) Check wheel bearings for leaks (para 10-2).
- (3) If leaks are found replace seal(s) (para 10-2).

- (1) Check differential and pinion drive yoke seal for leaks.
- (2) If leaks are found, notify unit maintenance.

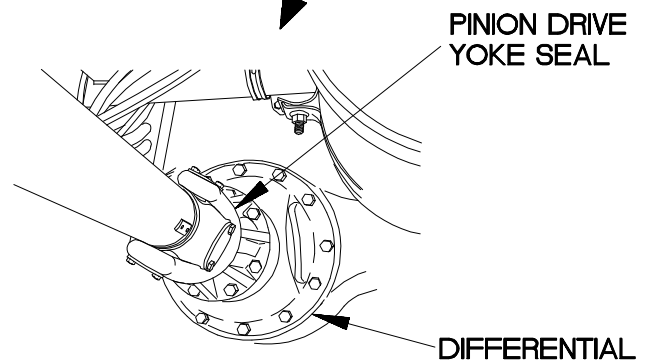
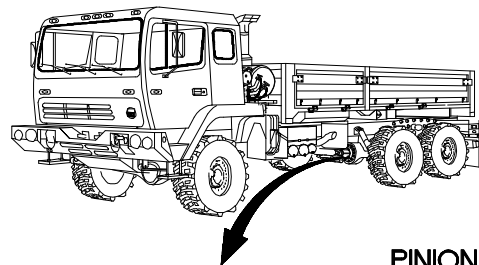

4bn0101b

n1. AXLE DIFFERENTIAL(S) NOISY (CONT)

KNOWN INFO
No visible leaks of planetary wheel ends or wheel bearings. No visible leaks of axle differential or pinion drive yoke.
POSSIBLE PROBLEMS
Damaged axle differential. Low or contaminated oil in axle differential. Faulty pinion drive yoke.

TEST OPTIONS
Visual inspection
REASON FOR QUESTION
Axle differential(s) may be unusually noisy when operating if damaged.

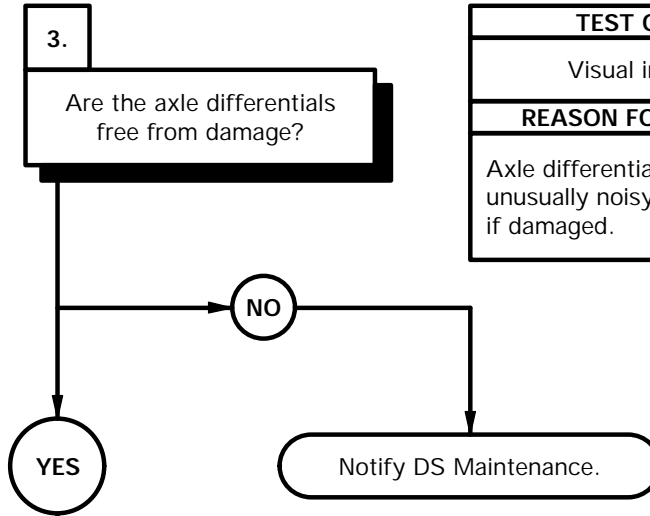

KNOWN INFO
No visible leaks of planetary wheel ends or wheel bearings. No visible leaks of axle differential or pinion drive yoke. Axle differential(s) free from damage.
POSSIBLE PROBLEMS
Low or contaminated oil in axle differential. Faulty pinion drive yoke.

TEST OPTIONS
Visual inspection
REASON FOR QUESTION
Low oil level will cause axle differential(s) to make unusual noises and lead to damage.

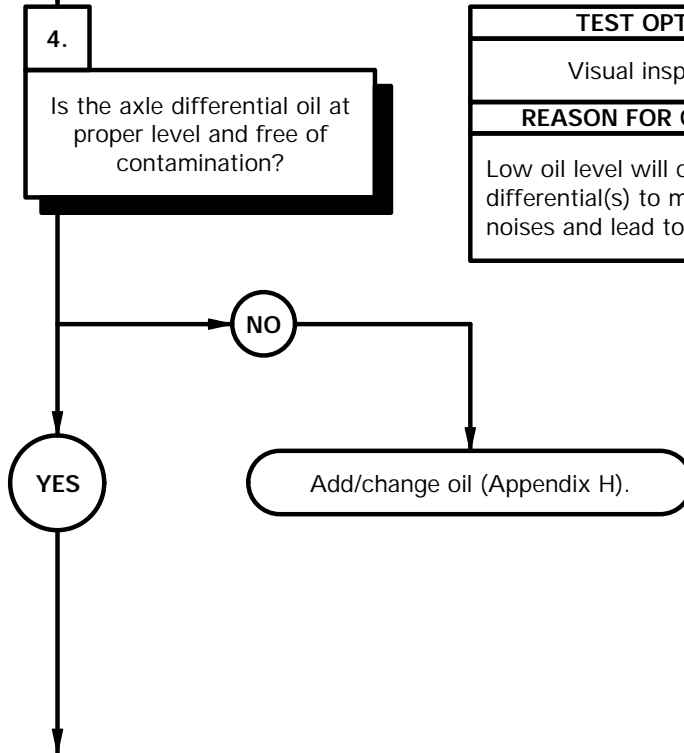

- (1) Check input and output shafts for leaks and damage.
- (2) Check axle differential for loose, missing, or damaged hardware.
- (3) If axle differential is damaged, Notify DS Maintenance.
- (4) Check drive shaft and bearing caps for looseness.
- (5) If drive shaft is loose, perform Drive Shaft Troubleshooting (para 2-18).

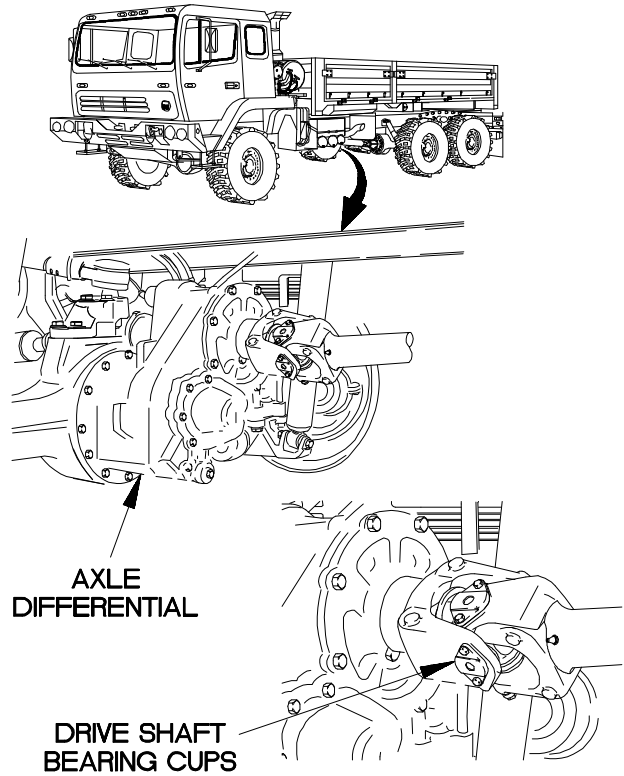

- (1) Check oil level according to (Appendix H).
- (2) Remove axle differential fill plug.
- (3) Insert finger into axle differential to check oil level.
- (4) Remove axle differential drain plug.
- (5) Allow differential oil to drain into pan.
- (6) Check oil for contamination. If metal chips are present, notify DS Maintenance.
- (7) Install axle differential drain plug.
- (8) Fill axle differential with oil (Appendix H).
- (9) Install axle differential fill plug.

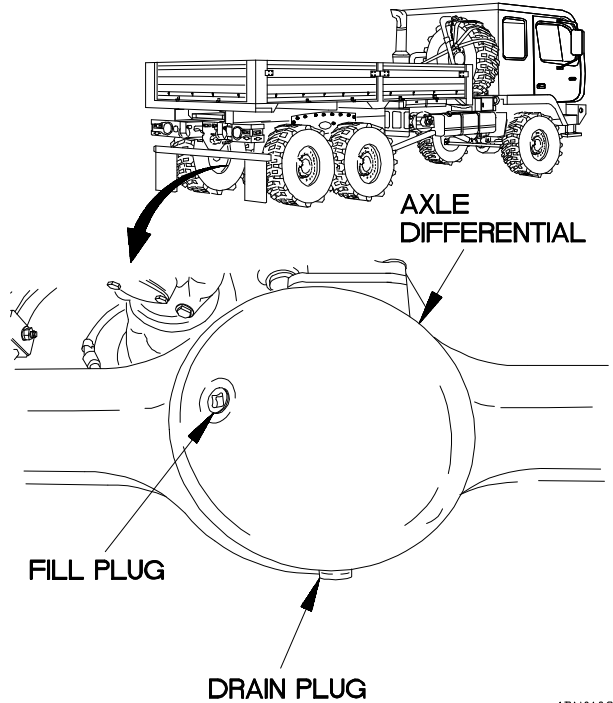

4BN0102B

n1. AXLE DIFFERENTIAL(S) NOISY (CONT)

KNOWN INFO
No visible leaks of planetary wheel ends or wheel bearings. No visible leaks of axle differential or pinion drive yoke. Axle differential(s) free from damage. Axle differential oil OK.
POSSIBLE PROBLEMS
Faulty pinion drive yoke.

5.
Is pinion drive yoke secure and free from damage?

TEST OPTIONS
Visual inspection
REASON FOR QUESTION
A loose or damaged pinion drive yoke may cause axle differential(s) to be unusually noisy when operating.

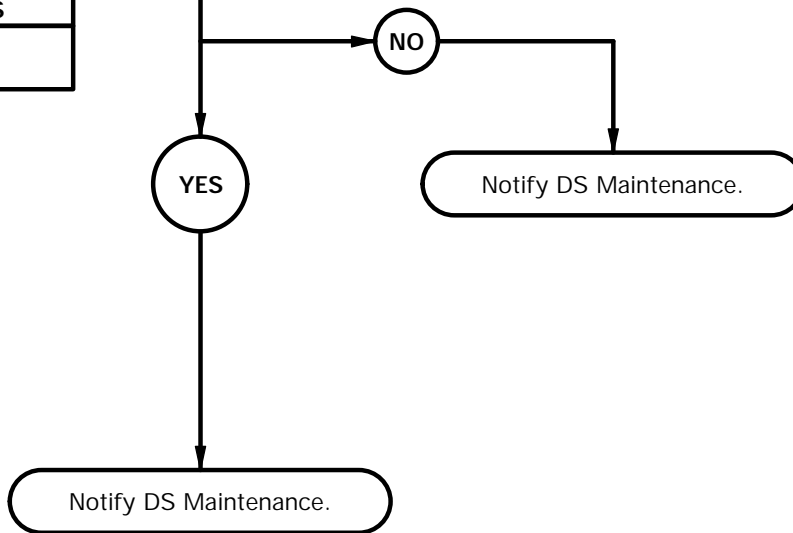

- (1) Check pinion drive yoke for looseness by attempting to rotate pinion drive yoke in both directions and listening for unusual backlash noise.
- (2) If pinion drive yoke is damaged, notify DS Maintenance.
- (3) If pinion drive yoke is not damaged, notify DS Maintenance.

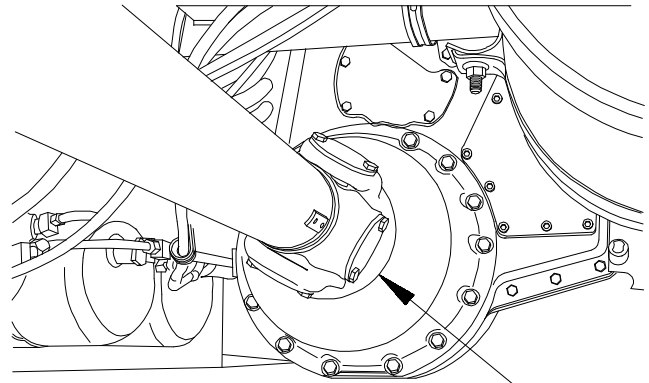

**PINION
DRIVE
YOKE**

Xbn0103b

2-26. STEERING TROUBLESHOOTING

This paragraph covers Steering Troubleshooting. The Steering Fault Index, Table 2-54, lists faults for the Steering of the vehicle.

Table 2-54. Steering Fault Index

Fault No.	Description	Page
p1.	Hard to Steer	2-2152
p2.	Wanders, Pulls to One Side, or Shimmies	2-2158
p3.	Excessive Play When Turning Steering Wheel	2-2164
p4.	No Response When Turning Steering Wheel	2-2168

p1. HARD TO STEER	
INITIAL SETUP	
Equipment Conditions Engine running (TM 9-2320-366-10-1).	Tools and Special Tools Tool Kit, Genl Mech (Item 46, Appendix C)
Personnel Required (2)	Materials/Parts Locknut (Item 68, Appendix G)

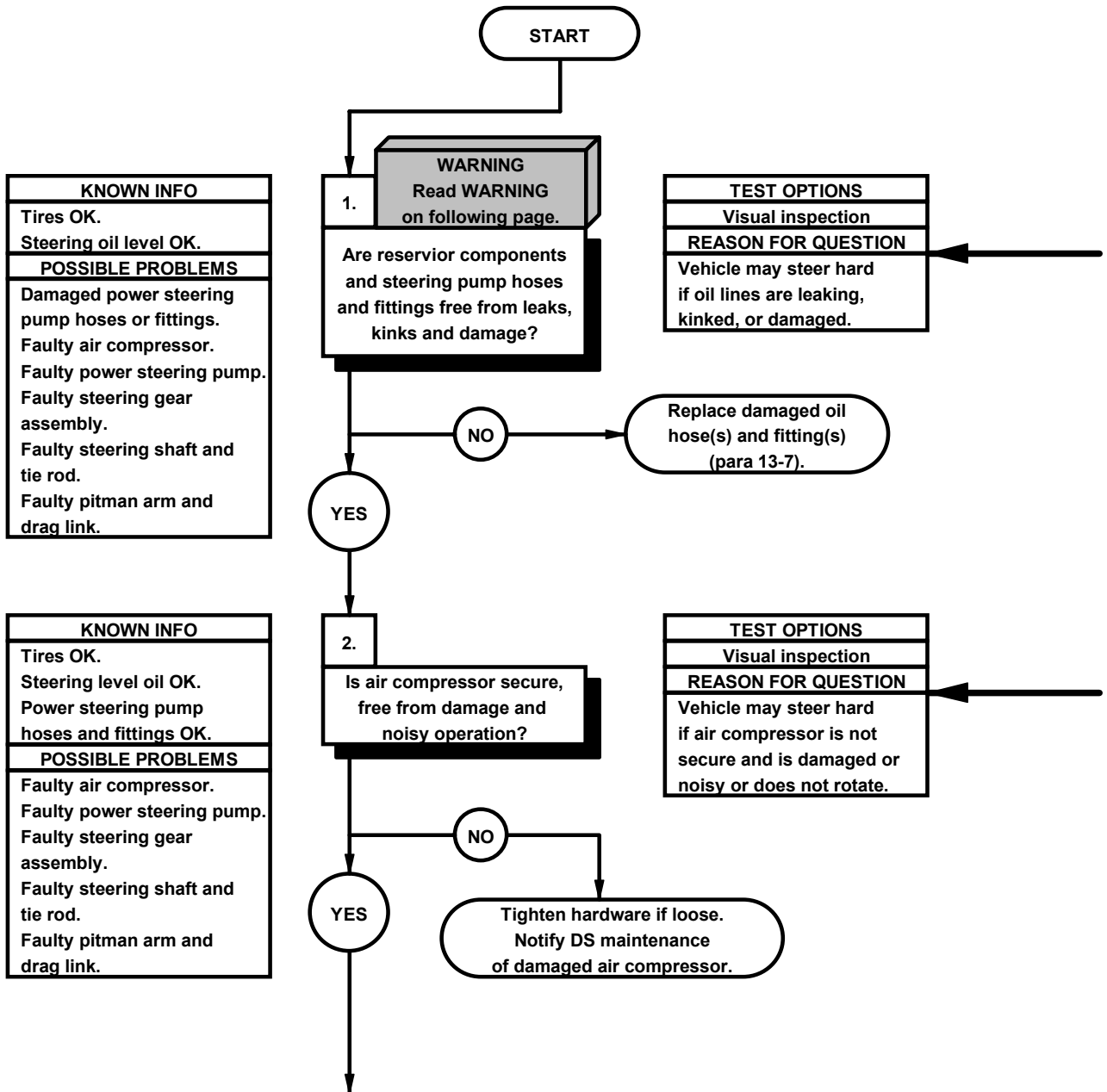

WARNING

- Engine compartment and its components may be hot to the touch. Extreme care should be taken when checking for leaks in the engine compartment. Failure to comply may result in burns or injury to personnel.
- Engine compartment includes a partially covered fan blade. Extreme care should be taken when working in the engine compartment. Failure to comply may cause injury to personnel.

NOTE

Refer to steering hydraulic hose schematic for steering hose locations.

Check reservoir components and steering hoses and fittings for leakage, kinks and damage.

Check air compressor for loose or missing mounting hardware, damage and noisy operation and rotation.

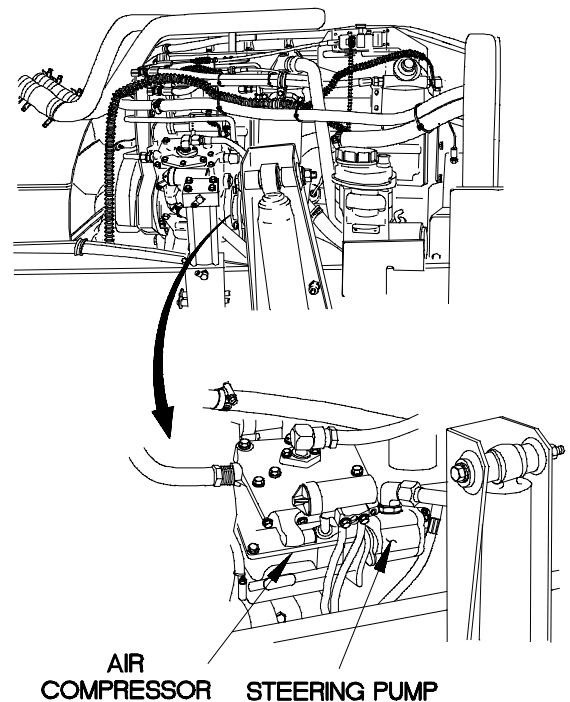

X2P0101A

p1. HARD TO STEER (CONT)

KNOWN INFO
Tires OK. Steering oil level OK. Power steering pump oil hoses and fittings OK. Air compressor OK. Power steering pump OK. Steering gear assembly OK.
POSSIBLE PROBLEMS
Faulty steering shaft and tie rod. Faulty pitman arm and drag link.

3.

Is steering shaft and tie rod properly lubricated, secure, and free from damage?

TEST OPTIONS
Visual inspection Steering Shaft/Tie Rod Test
REASON FOR QUESTION
Vehicle may steer hard if steering shaft or tie rod is loose, damaged, or requires lubrication.

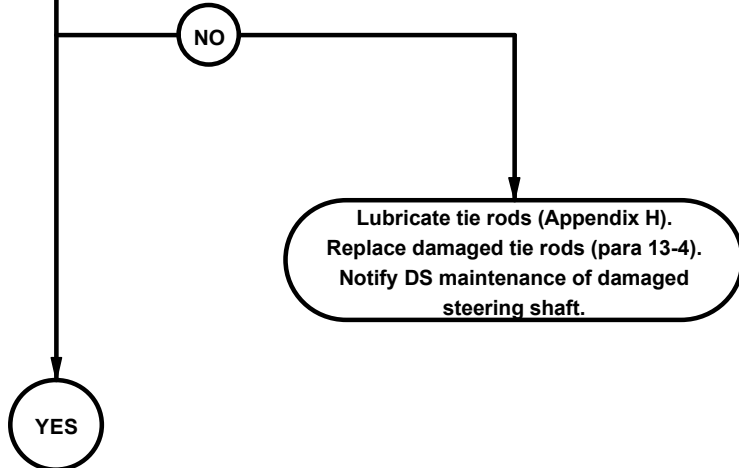

KNOWN INFO
Tires OK. Steering oil level OK. Power steering pump oil hoses and fittings OK. Air compressor OK. Power steering pump OK. Steering gear assembly OK. Steering shaft and tie rods OK.
POSSIBLE PROBLEMS
Faulty pitman arm and drag link.

4.

Is pitman arm and drag link secure, and free from damage?

TEST OPTIONS
Visual inspection Pitman Arm/Drag Link Test
REASON FOR QUESTION
Vehicle may steer hard if pitman arm or drag link is loose or damaged.

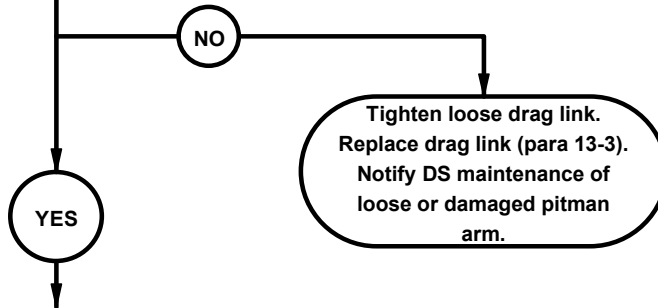

Check steering shaft and tie rod for damage, and loose or missing mounting hardware. Refer to Appendix H to lubricate tie rods.

STEERING SHAFT/TIE ROD TEST

- (1) Grasp steering shaft to ensure there is no up and down play.
- (2) Grasp tie rod to ensure there is no up and down or left and right play.

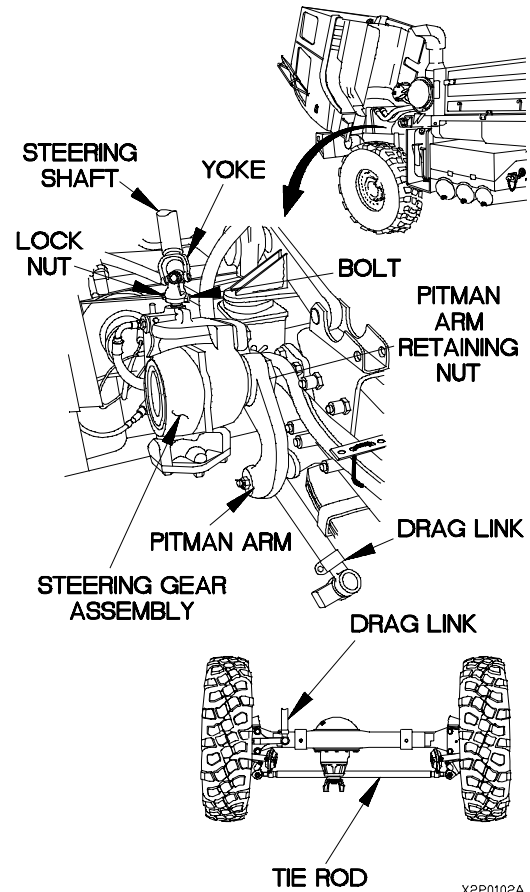

X2P0102A

Check pitman arm and drag link for damage, and loose or missing mounting hardware.

PITMAN ARM/DRAG LINK TEST

- (1) Check nut securing pitman arm to steering gear assembly. Ensure there is no play.
- (2) Grasp drag link and ensure there is no play left and right or up and down.
- (3) Check for loose bolts, nuts, and clamps on drag link.

p1. HARD TO STEER (CONT)

KNOWN INFO
Tires OK. Steering oil level OK Power steering pump oil hoses and fittings OK. Air compressor OK.
POSSIBLE PROBLEMS
Faulty power steering pump. Faulty steering gear assembly. Faulty steering shaft and tie rod. Faulty pitman arm and drag link.

5.
Is power steering pump free from leaks or damage and is required mounting hardware secure and free from damage?

TEST OPTIONS
Visual inspection
REASON FOR QUESTION
Vehicle may be hard to steer if power steering pump is leaking, or mounting is loose or damaged.

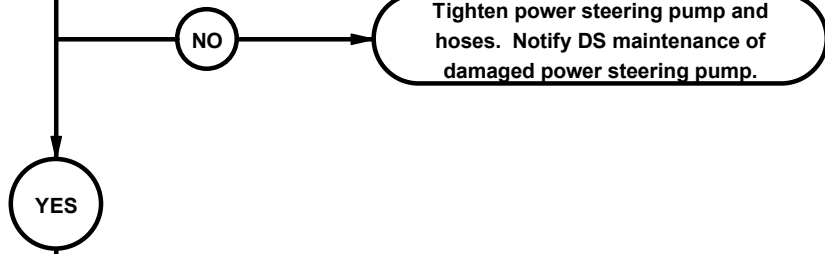

KNOWN INFO
Tires OK. Steering oil level OK. Power steering pump oil hoses and fittings OK. Air compressor OK. Power steering pump OK.
POSSIBLE PROBLEMS
Faulty steering gear assembly. Faulty steering shaft and tie rod. Faulty pitman arm and drag link.

6.
Does steering gear assembly output shaft turn freely by hand?

TEST OPTIONS
Steering Gear Assembly Test
REASON FOR QUESTION
Vehicle may steer hard if steering gear assembly output shaft is binding.

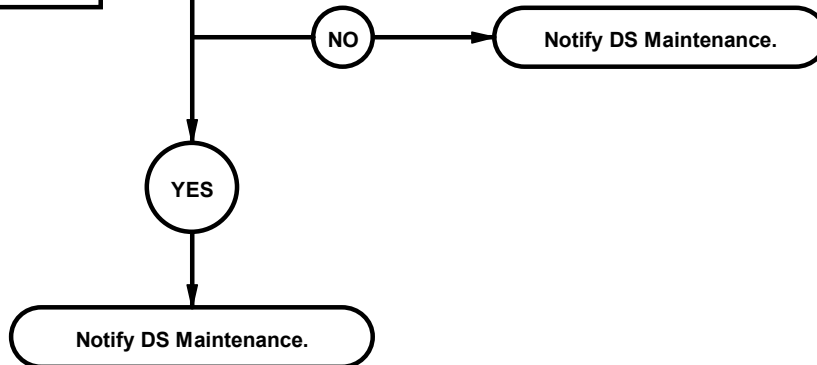

Check power steering pump for leaks, and for loose, missing, or damaged mounting hardware. Lower cab (TM 9-2320-366-10-1). Shutdown engine (TM 9-2320-366-10-1). Raise cab (TM 9-2320-366-10-1).

NOTE

An alignment mark shall be marked on yoke and steering gear assembly to ensure ease during installation.

STEERING GEAR TEST

- (1) Remove bolt and self-locking nut from lower yoke of steering gear arm. Discard self-locking nut.
- (2) Remove yoke from top steering gear assembly shaft.
- (3) Remove drag link (para 13-3).
- (4) Turn top steering gear assembly shaft to check for binding and proper output. Notify DS maintenance if steering gear assembly fails to turn smoothly or if it binds when top shaft is turned.
- (5) Install drag link (para 13-3).
- (6) Position yoke onto top steering gear assembly shaft.
- (7) Install bolt and self-locking nut into yoke to secure yoke to top steering gear assembly shaft.

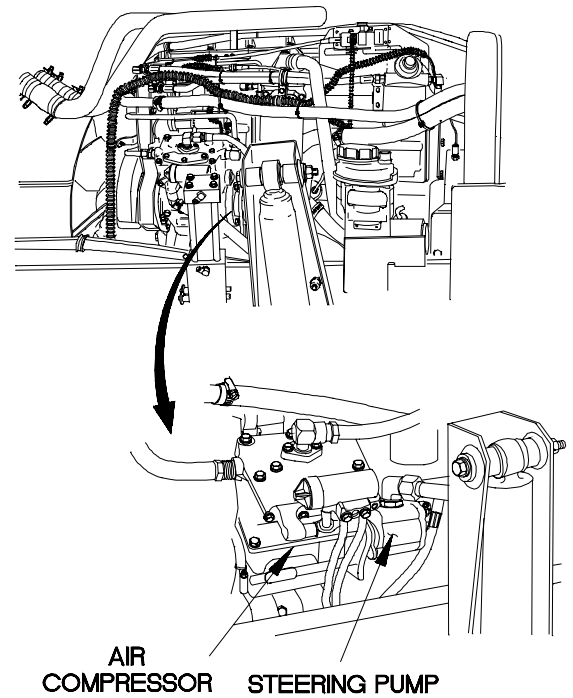

X2P0103A

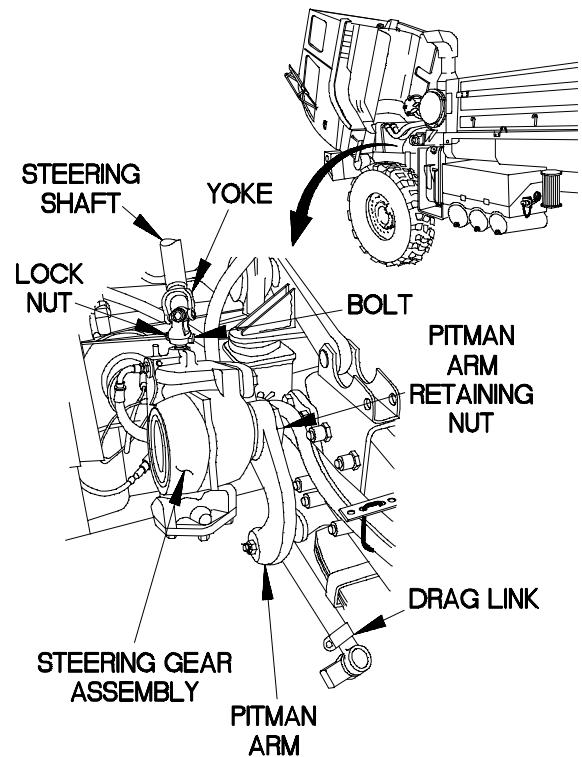

X2P0104A

p2. WANDERS, PULLS TO ONE SIDE, OR SHIMMIES

INITIAL SETUP

Equipment Conditions
Engine shut down (TM 9-2320-366-10-1).

Tools and Special Tools
Tool Kit, Genl Mech (Item 46, Appendix C)

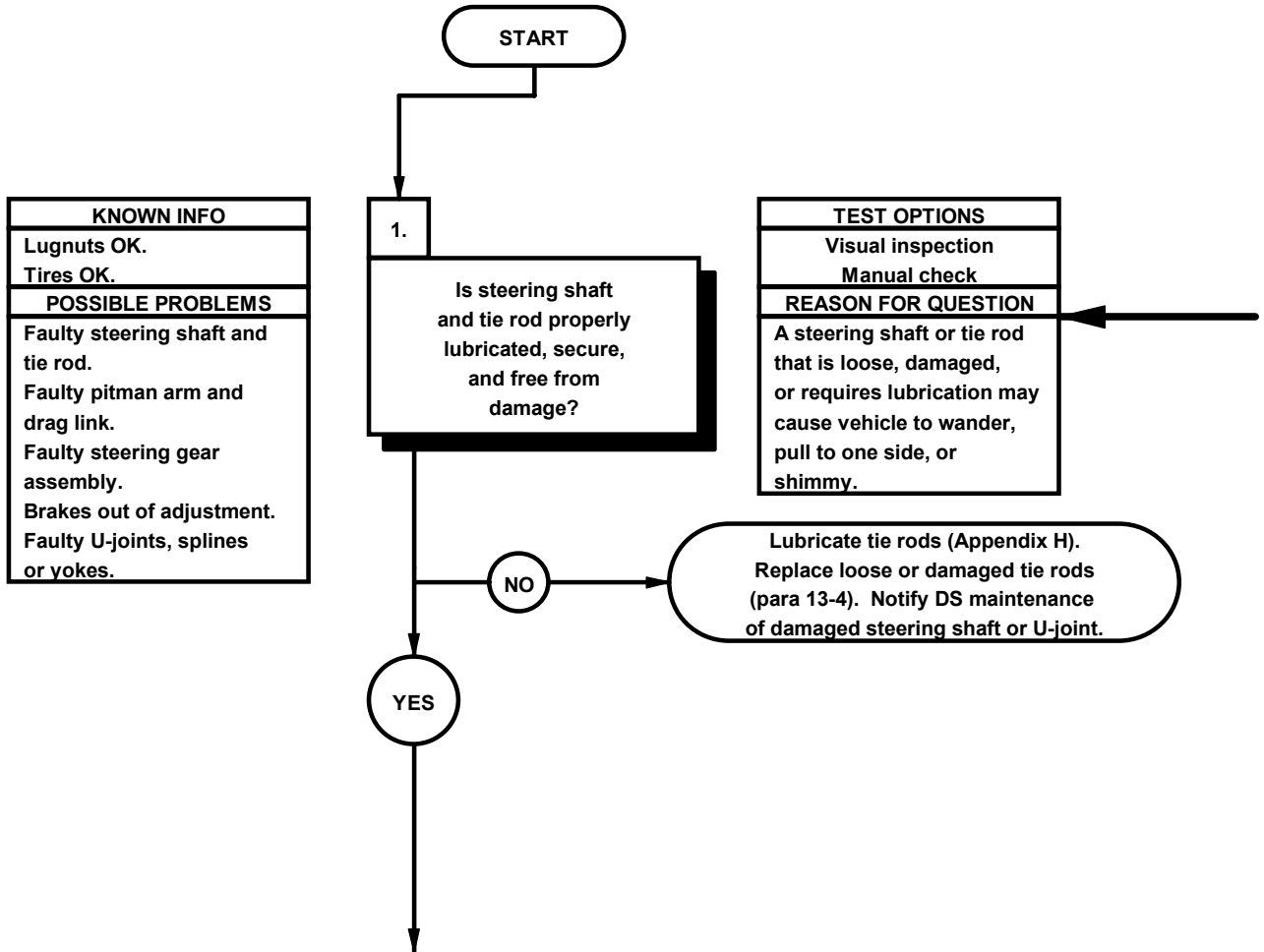

- (1) Raise cab (TM 9-2320-366-10-1).
- (2) Check steering shaft and tie rods for damage, and loose or missing mounting hardware. Refer to Appendix H to lubricate tie rods.
- (3) Grasp the steering gear shaft and ensure there is no up and down play.
- (4) Grasp the tie rod and ensure there is no up and down or sideways play.

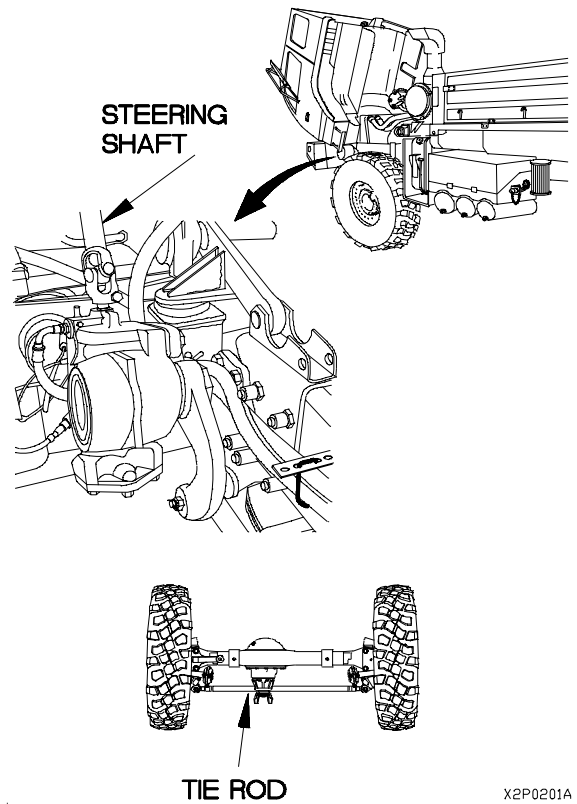

X2P0201A

p2. WANDERS, PULLS TO ONE SIDE, OR SHIMMIES (CONT)

KNOWN INFO
Lugnuts OK. Tires OK. Steering shaft and tie rod OK. U-joints, splines and yoke OK.
POSSIBLE PROBLEMS
Faulty pitman arm and drag link. Faulty steering gear assembly. Brakes out of adjustment.

2.
Is pitman arm and drag link properly secure and free from damage?

TEST OPTIONS
Visual inspection Manual check
REASON FOR QUESTION
A pitman arm or drag link that is loose, damaged, may cause vehicle to wander, pull to one side, or shimmy.

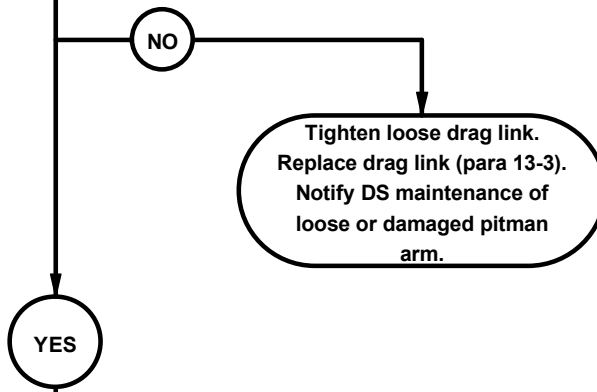

KNOWN INFO
Lugnuts OK. Tires OK. Steering shaft and tie rod OK. U-joints, splines and yokes OK. Pitman arm and drag link OK.
POSSIBLE PROBLEMS
Faulty steering gear assembly. Brakes out of adjustment.

3.
Is steering gear assembly free from damage, and mounted securely?

TEST OPTIONS
Visual inspection Manual check
REASON FOR QUESTION
Damaged steering gear assembly or mounting hardware may cause vehicle to wander, pull to one side, or shimmy.

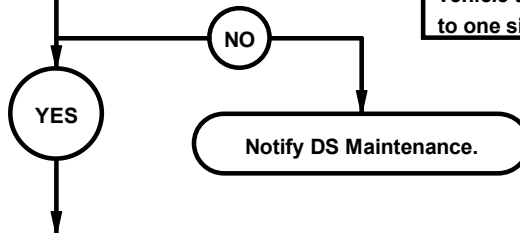

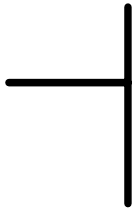

- (1) Check pitman arm and drag link for damage, and loose or missing mounting hardware.
- (2) Grasp pitman arm and ensure it and drag link are free of play.

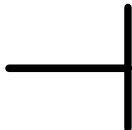
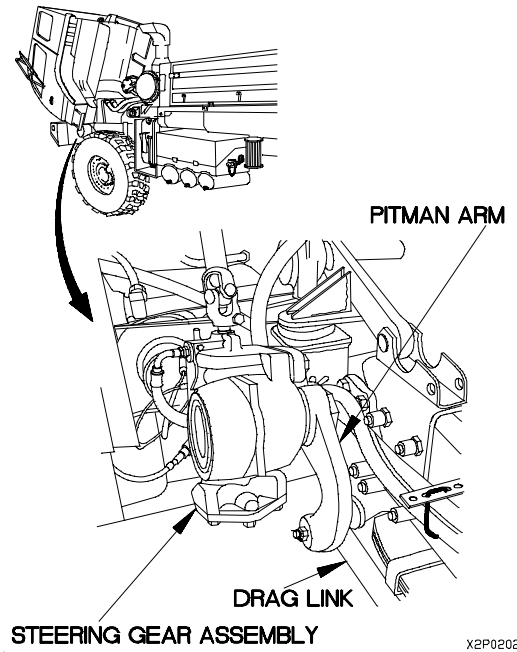

- (1) Check steering gear assembly for damage, and loose or missing mounting hardware.
- (2) Lower cab (TM 9-2320-366-10-1).

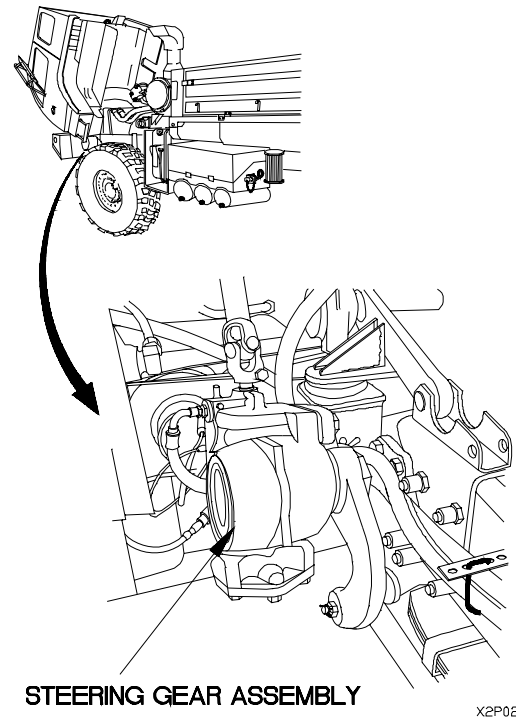

p2. WANDERS, PULLS TO ONE SIDE, OR SHIMMIES (CONT)

KNOWN INFO
Lugnuts OK.
Tires OK.
Steering shaft and tie rod OK.
U-joints, splines and yoke OK.
Pitman arm and drag link OK.
Steering gear assembly OK.
POSSIBLE PROBLEMS
Brakes out of adjustment.

4.
Are brakes properly adjusted?

TEST OPTIONS
Refer to brake adjustment procedure (para 11-2 or 11-3).
REASON FOR QUESTION
Vehicle may wander, pull to one side, or shimmy if brakes are not properly adjusted.

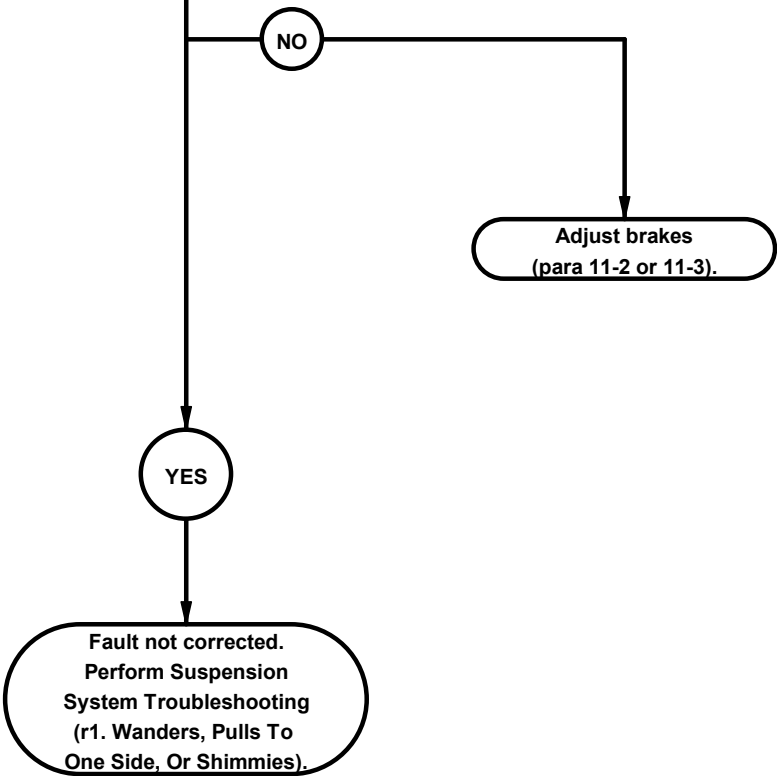

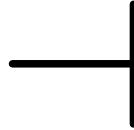

Refer to para 11-2 or 11-3 to adjust brakes.

p3. EXCESSIVE PLAY WHEN TURNING STEERING WHEEL	
INITIAL SETUP	
Equipment Conditions Engine shut down (TM 9-2320-366-10-1). Cab raised (TM 9-2320-366-10-1).	Tools and Special Tools Tool Kit, Genl Mech (Item 46, Appendix C)
Personnel Required (2)	Materials/Parts Locknut (Item 68, Appendix G)

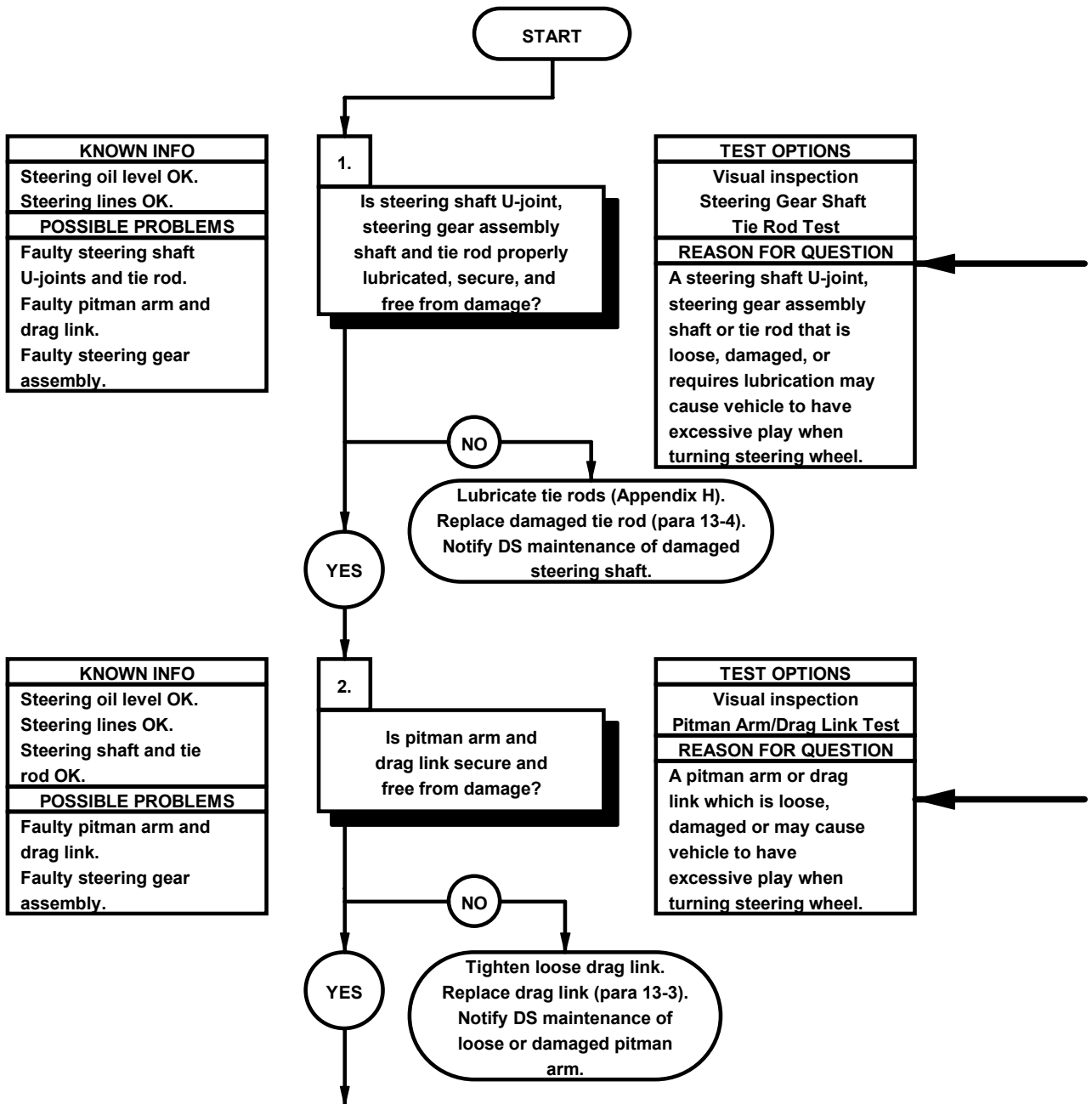

Check steering shaft U-joint, steering gear assembly shafts, and tie rod for damage and loose or missing mounting hardware. Refer to Appendix H to lubricate tie rods.

NOTE

An alignment mark shall be used on yoke and steering gear assembly to ensure ease during installation.

STEERING GEAR SHAFT TIE ROD TEST

- (1) Grasp steering shaft and ensure there is no up and down play.
- (2) Remove self-locking nut and bolt securing yoke of top steering shaft to steering gear assembly shaft. Discard self-locking nut.
- (3) Remove yoke from top steering gear assembly shaft.
- (4) Ensure spline shaft of steering gear assembly and yoke of steering shaft are not damaged.
- (5) Grasp tie rod and ensure there is no up and down or left or right play.

Check pitman arm and drag link for damage and loose or missing mounting hardware.

PITMAN ARM/DRAW LINK TEST

- (1) Check nut securing pitman arm to steering gear assembly. Ensure there is no play.
- (2) Grasp drag link and ensure there is no play left or right and up or down.
- (3) Check for loose bolts, nuts, and clamps on drag link.

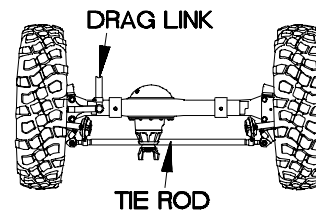
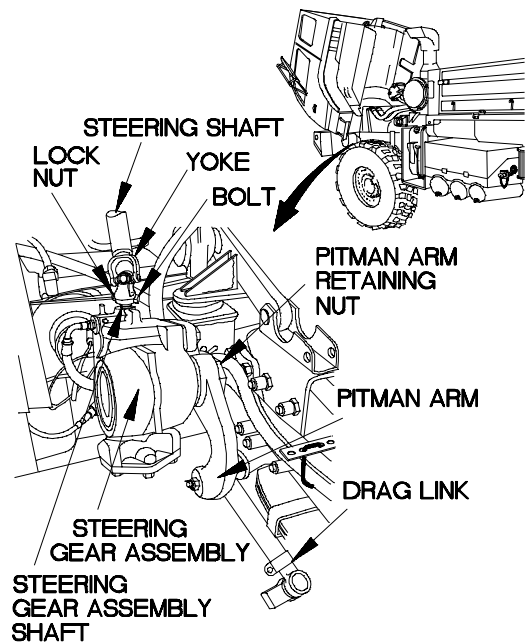

X2P0301-

p3. EXCESSIVE PLAY WHEN TURNING STEERING WHEEL (CONT)

KNOWN INFO
Steering oil level OK.
Steering lines OK.
Steering linkage OK.
POSSIBLE PROBLEMS
Faulty steering gear assembly.

3.

Does pitman arm move immediately when turning steering wheel?

TEST OPTIONS
Steering Gear Preload Test
REASON FOR QUESTION
If steering gear input shaft turns before pitman arm begins to move, steering gear assembly has excessive play.

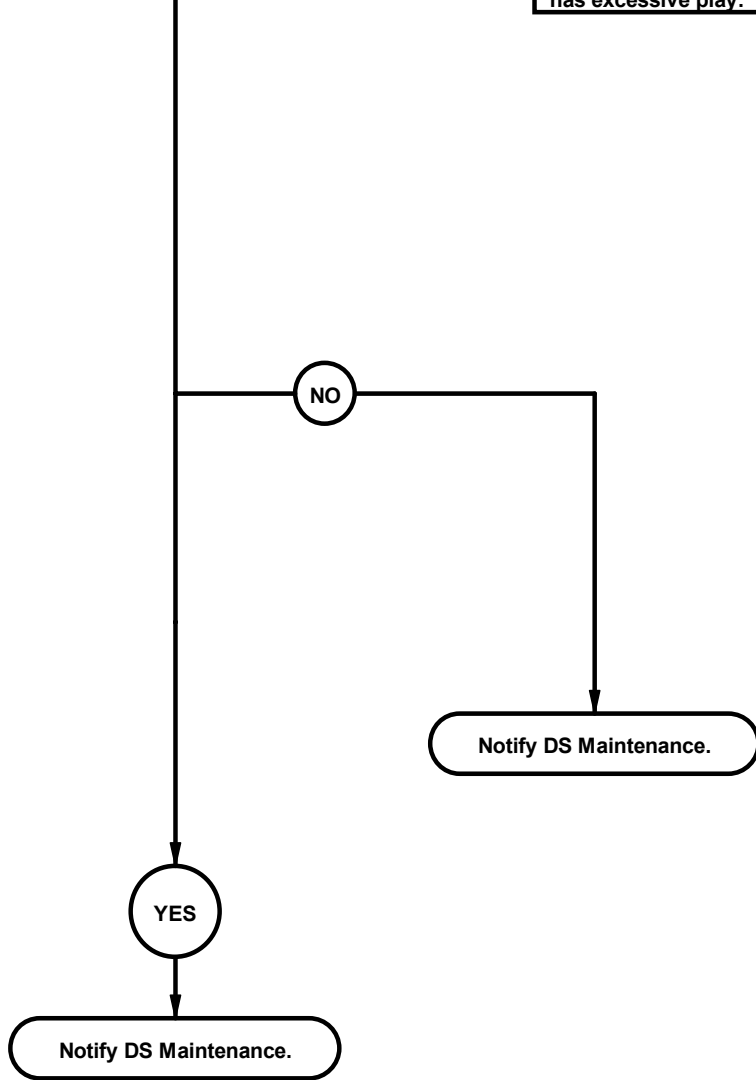

STEERING GEAR PRELOAD TEST

- (1) Remove drag link (para 13-3).
- (2) Pull pitman arm back and forth to check for binding and proper output. If pitman arm fails to turn smoothly or if it binds and top shaft does not turn immediately, steering gear assembly is damaged.
- (3) Install drag link (para 13-3).
- (4) Position yoke onto top steering gear assembly shaft.
- (5) Install bolt and self-locking nut onto yoke to secure yoke to top steering gear assembly shaft.
- (6) Lower cab (TM 9-2320-366-10-1).

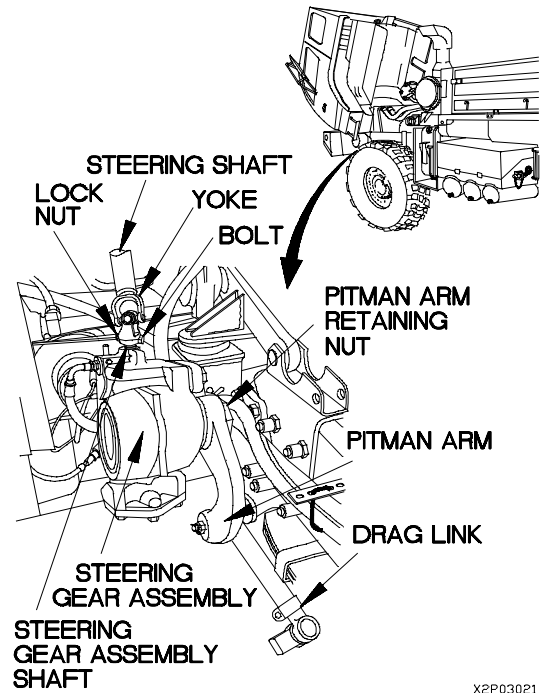

X2P03021

p4. NO RESPONSE WHEN TURNING STEERING WHEEL	
INITIAL SETUP	
Equipment Conditions Engine shut down (TM 9-2320-366-10-1). Cab raised (TM 9-2320-366-10-1).	Tools and Special Tools Tool Kit, Genl Mech (Item 46, Appendix C)
	Materials/Parts Locknut (Item 68, Appendix G)

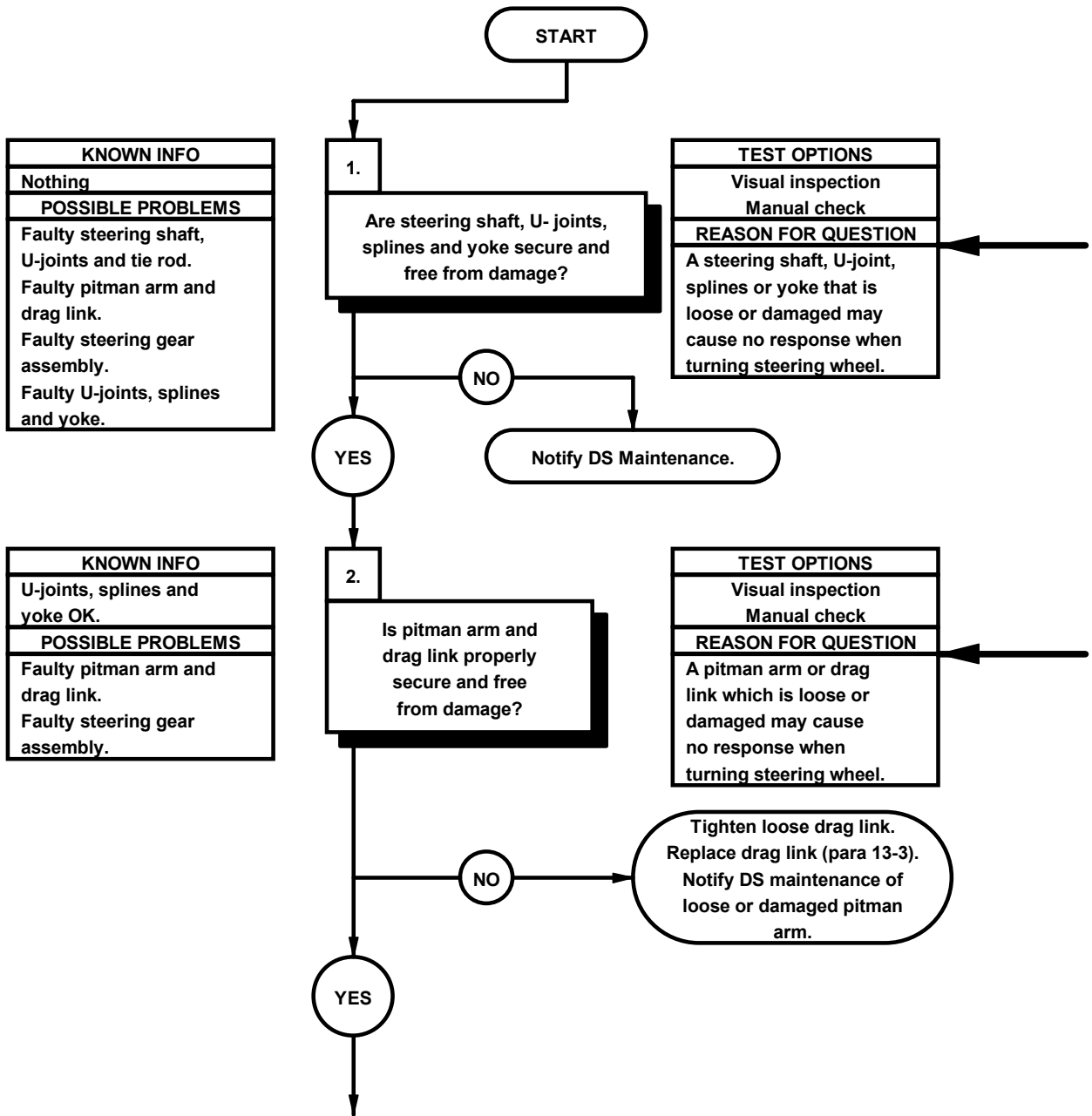

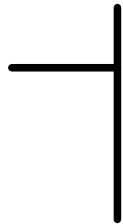

- (1) Check steering shaft for looseness and damage.
- (2) Grasp steering shaft and ensure it is free of play.
- (3) Repeat step (2) while observing yoke, U-joint and locknuts.

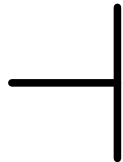
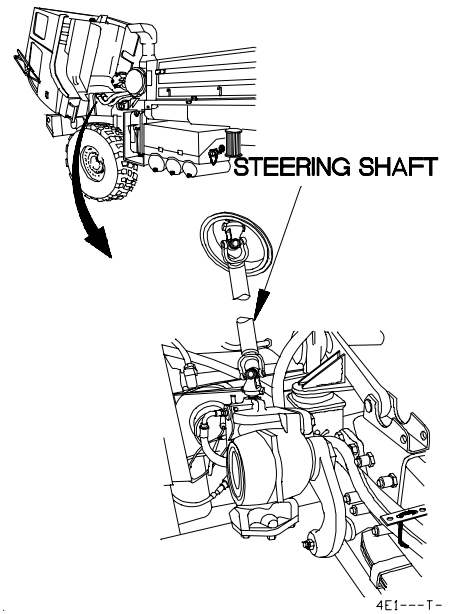

- (1) Check pitman arm and drag link for damage and loose or missing mounting hardware.
- (2) Grasp pitman arm and ensure it and drag link are free of play.

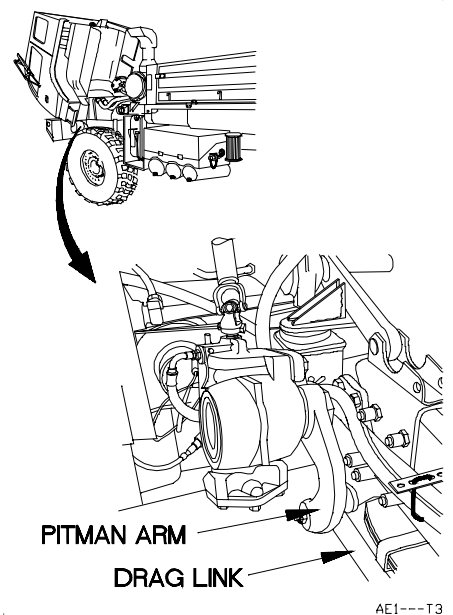

p4. NO RESPONSE WHEN TURNING STEERING WHEEL (CONT)

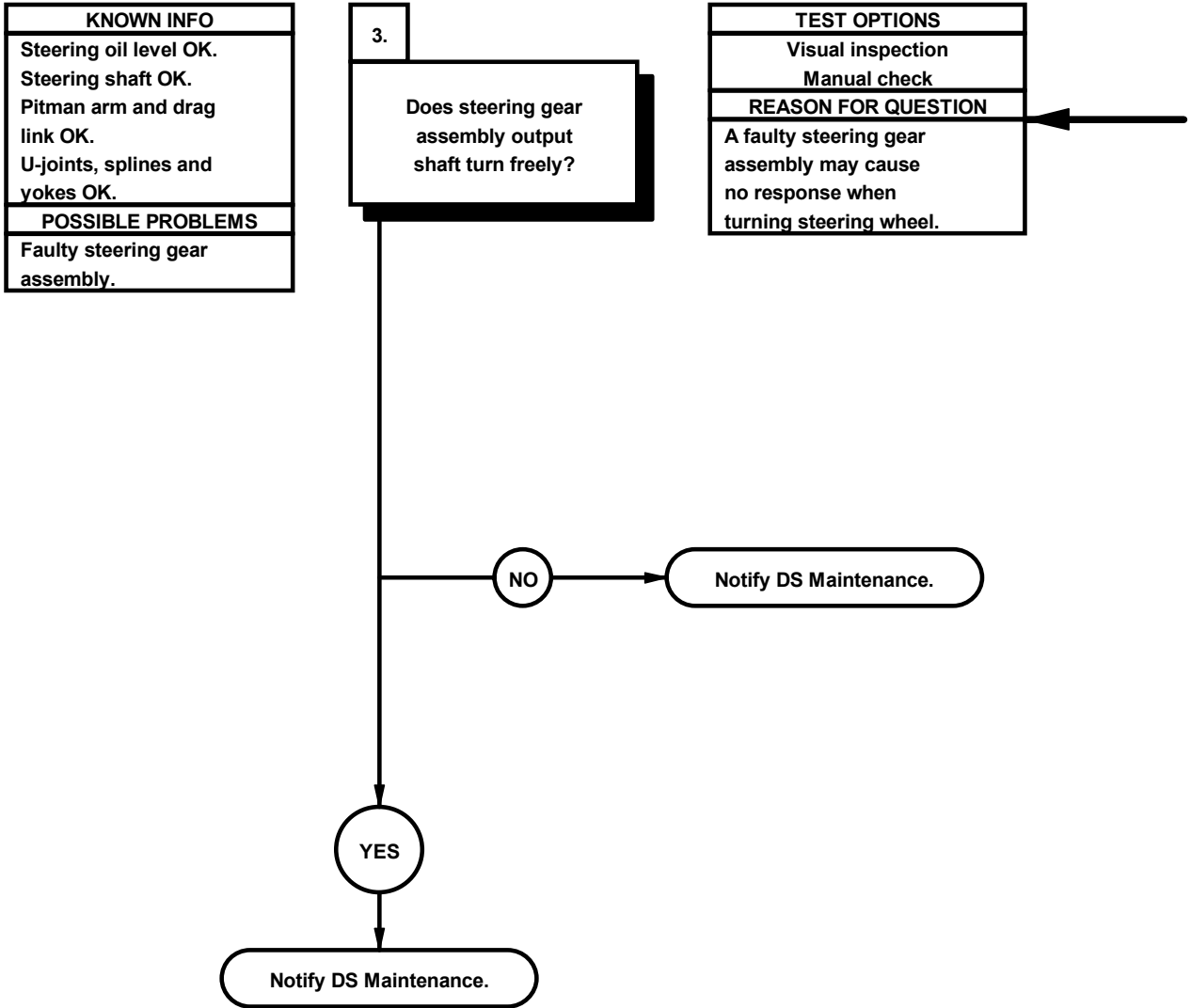

NOTE

An alignment mark shall be made on yoke and steering gear assembly shaft prior to disassembly to ensure proper alignment during installation.

STEERING GEAR TEST

- (1) Remove bolt and locknut from lower yoke of steering gear arm. Discard locknut.
- (2) Remove yoke from top steering gear assembly shaft.
- (3) Remove drag link (para 13-3).
- (4) Turn pitman arm to check for binding and proper output. Notify DS Maintenance if steering gear assembly fails to turn smoothly or if it binds when top shaft is turned.
- (5) Install drag link (para 13-3).
- (6) Position yoke on steering gear assembly.
- (7) Install bolt and locknut into yoke to top steering gear assembly shaft.
- (8) Lower cab (TM 9-2320-366-10-1).

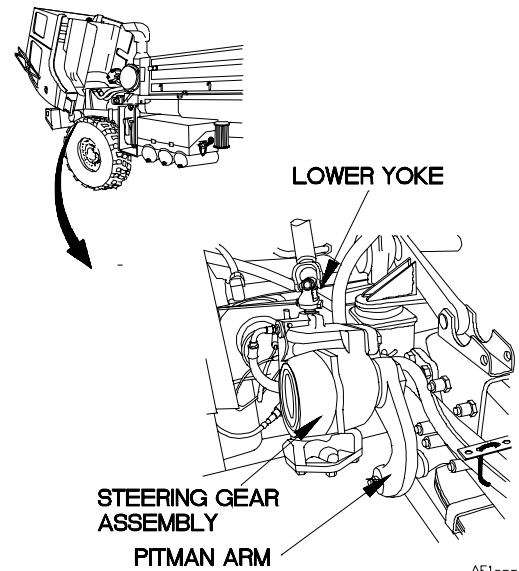

AE1---T2

2-27. FIFTH WHEEL TROUBLESHOOTING

This paragraph covers Fifth Wheel Troubleshooting. The Fifth Wheel Fault Index, Table 2-55, lists faults for the Fifth Wheel of the vehicle.

Table 2-55. Fifth Wheel Fault Index

Fault No.	Description	Page
q1.	Fifth Wheel Does Not Lock When Coupling Trailer to Tractor	2-2174
q2.	Excessive Movement of Trailer King Pin in Fifth Wheel	2-2178
q3.	Fifth Wheel Does Not Unlock When Disconnecting Trailer From Tractor	2-2182
q4.	Fifth Wheel Sliding Mechanism Does Not Operate	2-2186

q1. FIFTH WHEEL WILL NOT LOCK WHEN COUPLING TRAILER TO TRACTOR	
INITIAL SETUP	
Equipment Conditions Engine shut down (TM 9-2320-366-10-1).	Tools and Special Tools Tool Kit, Genl Mech (Item 46, Appendix C) Gun, Lubricating (Item 16, Appendix C)

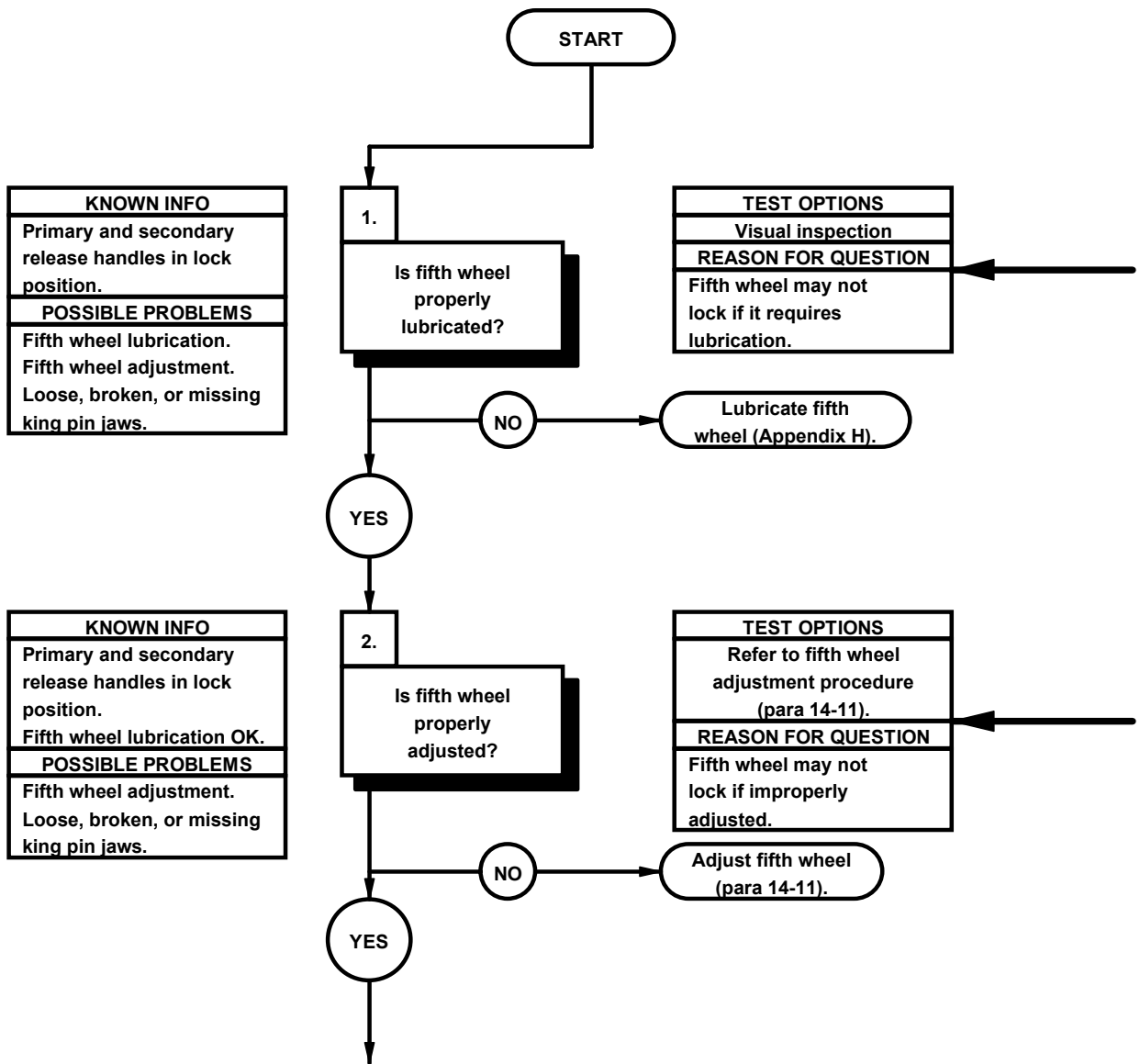

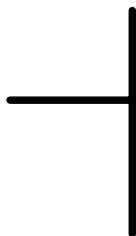

Refer to Appendix H to lubricate fifth wheel.

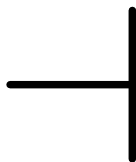

Refer to para 14-11 to check for proper fifth wheel adjustment.

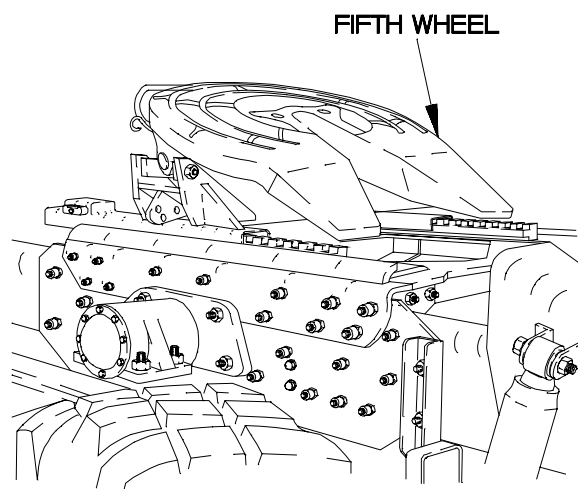

4200101A

q1. FIFTH WHEEL WILL NOT LOCK WHEN COUPLING TRAILER TO TRACTOR (CONT)

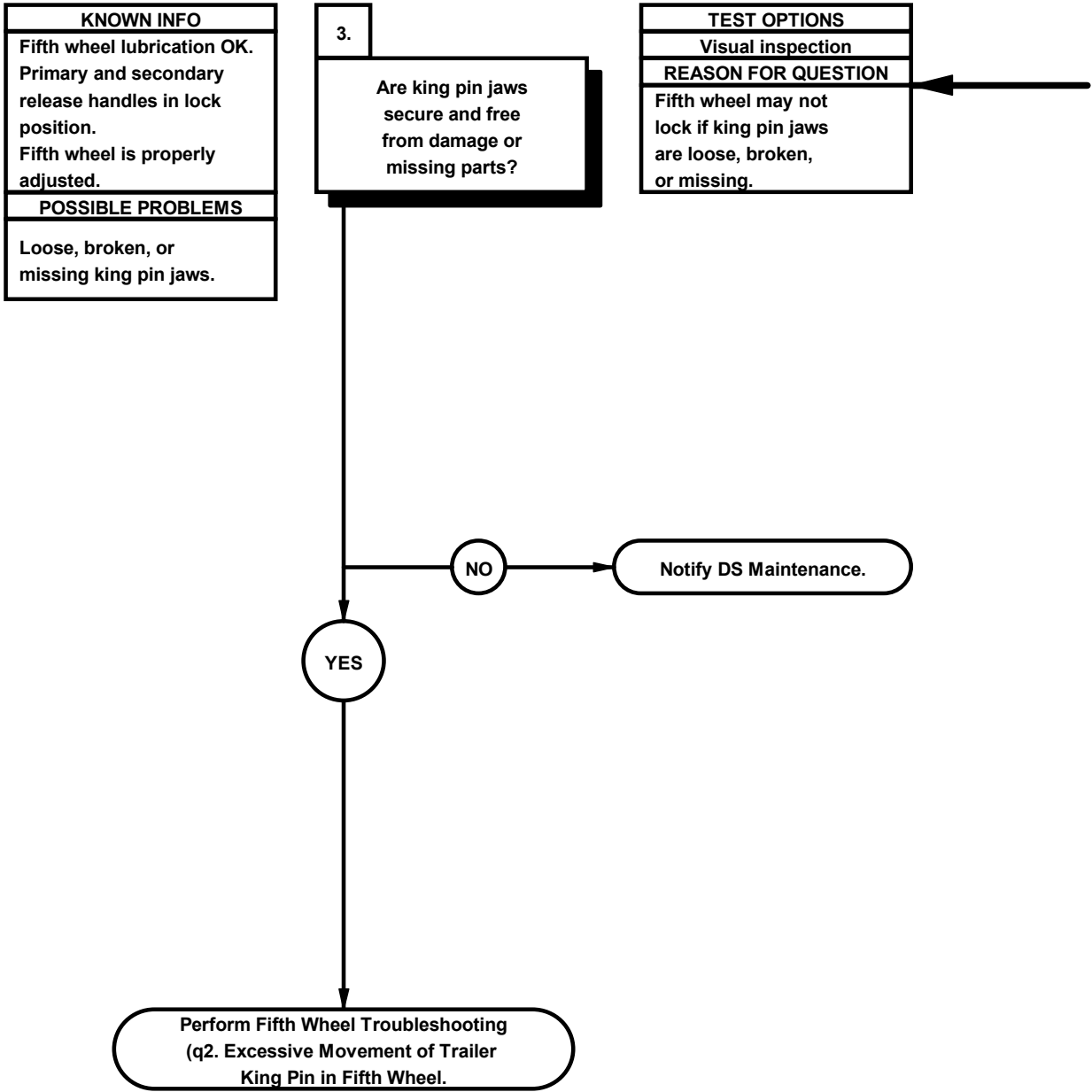

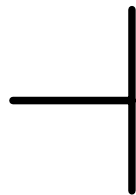

Check for loose, damaged, or missing king pin jaws.
Check that king pin jaws stay open when primary lock
release handle is in locked position
(TM 9-2320-366-10-1).

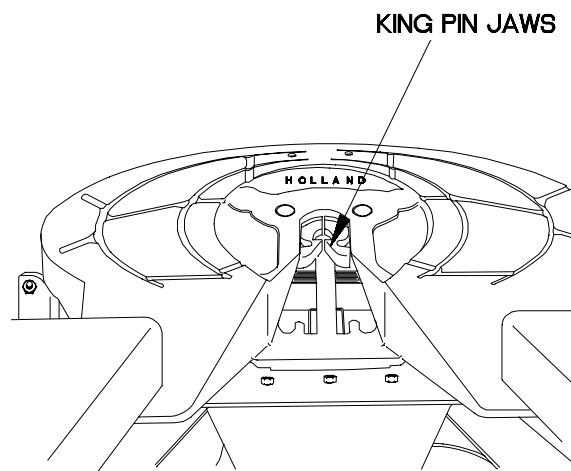

4200103A

q2. EXCESSIVE MOVEMENT OF TRAILER KING PIN IN FIFTH WHEEL

INITIAL SETUP

Equipment Conditions
 Engine shut down (TM 9-2320-366-10-1).

Tools and Special Tools
 Tool Kit, Genl Mech (Item 46, Appendix C)

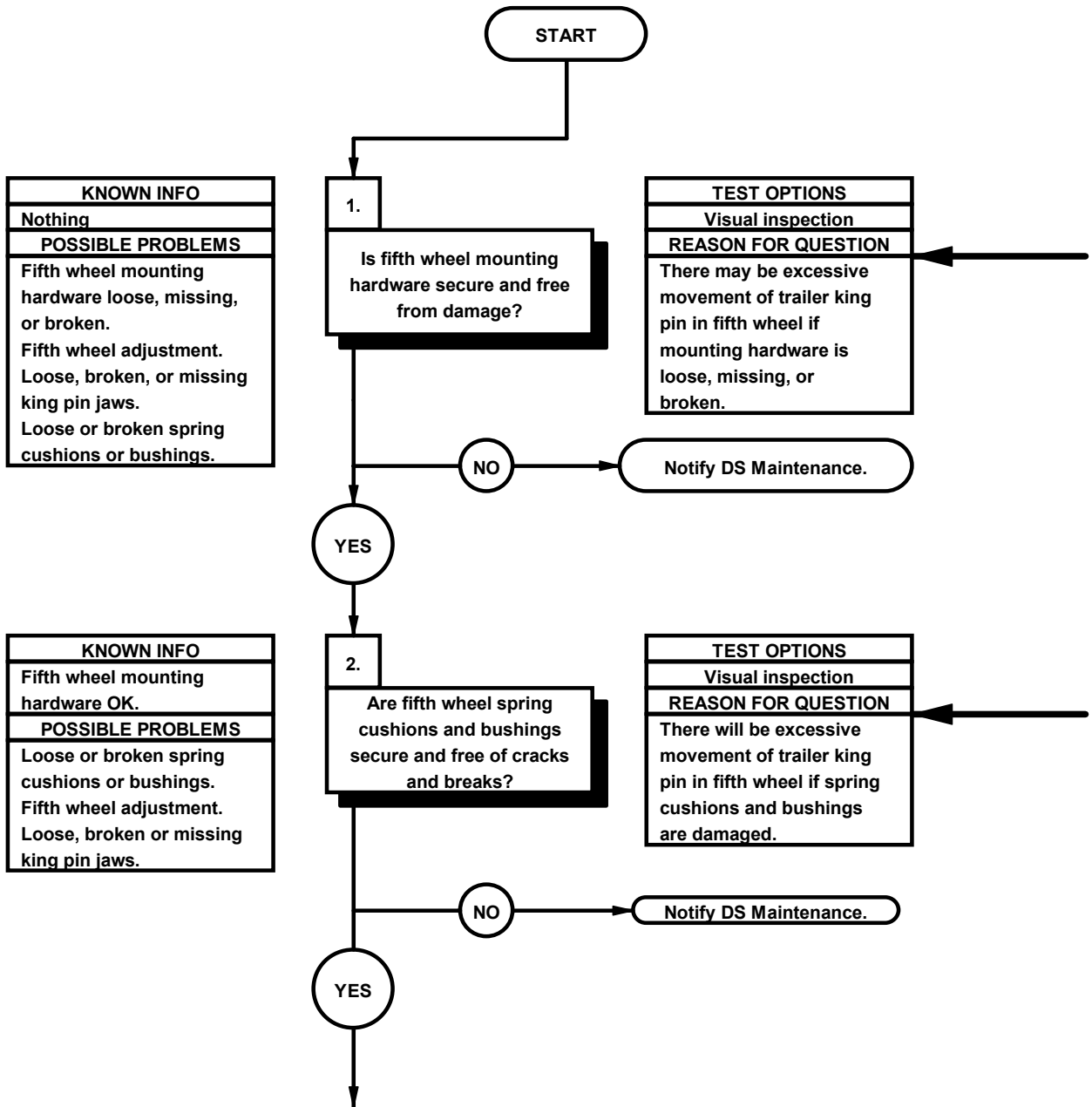

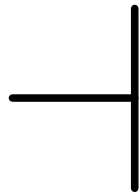

Check fifth wheel for loose, missing or broken mounting hardware.

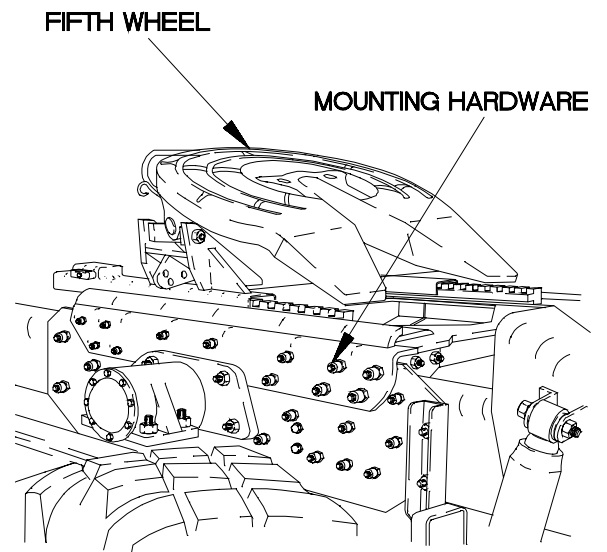

4200201A

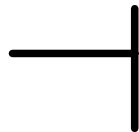

Check spring cushions and bushings in fifth wheel for looseness, cracks or breaks.

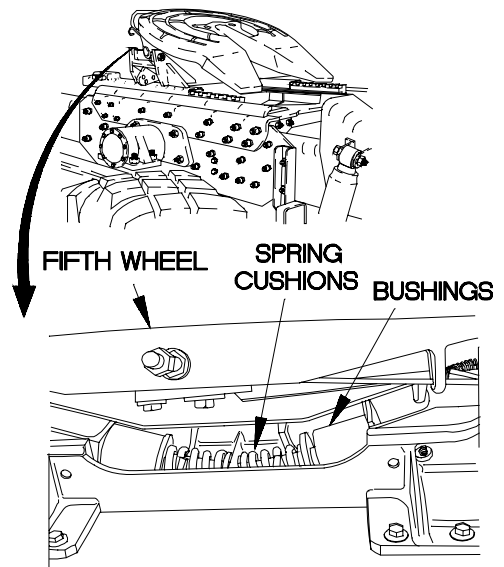

4200202A

q2. EXCESSIVE MOVEMENT OF TRAILER KING PIN IN FIFTH WHEEL (CONT)

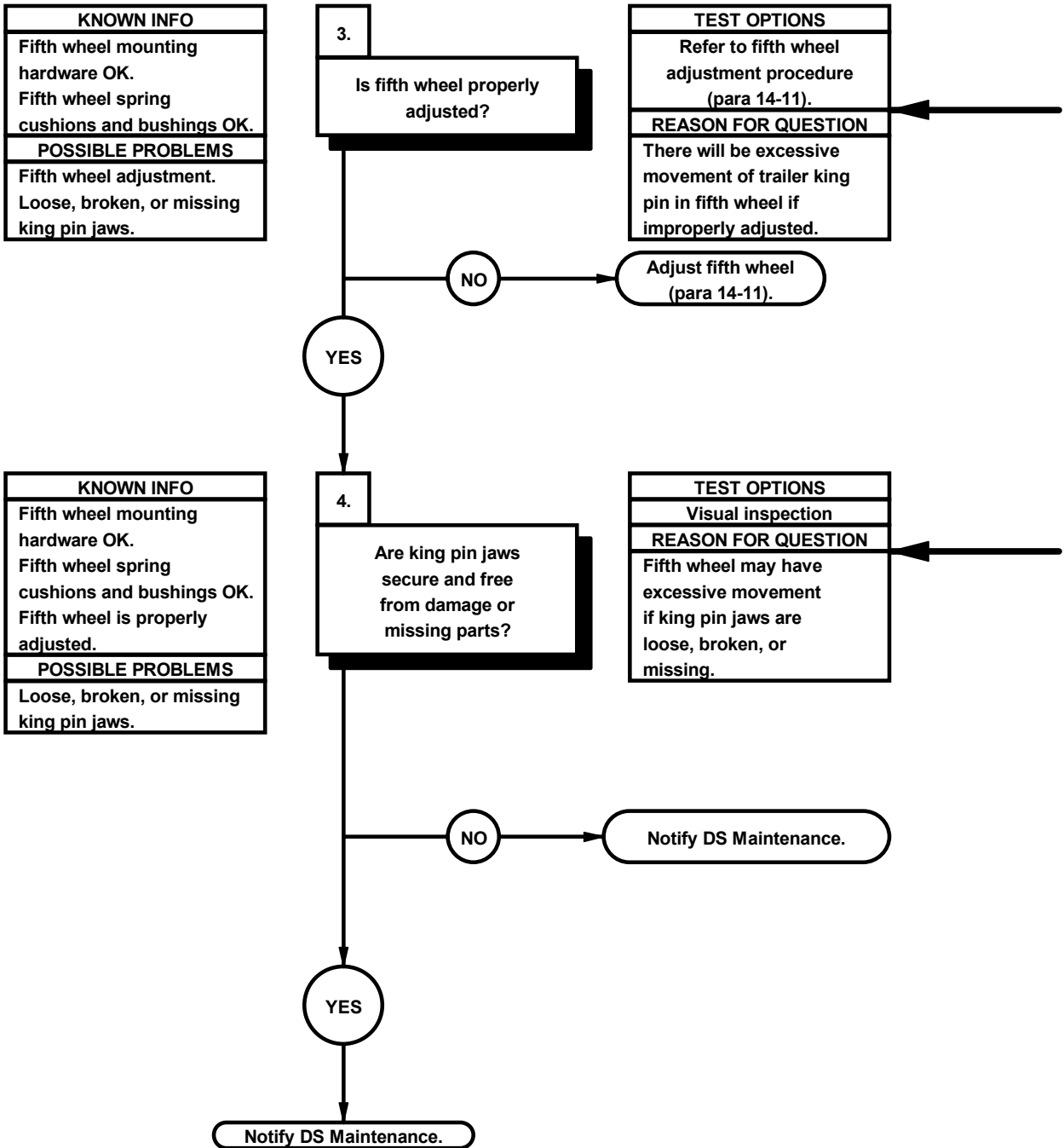

— | Refer to para 14-11 to check for proper fifth wheel adjustment.

— | Check for loose, damaged, or missing king pin jaws.
Check that king pin jaws stay open when primary lock release handle is in locked position (TM 9-2320-366-10-1).

g3. FIFTH WHEEL WILL NOT UNLOCK WHEN DISCONNECTING TRAILER FROM TRACTOR	
INITIAL SETUP	
Equipment Conditions Engine shut down (TM 9-2320-366-10-1).	Tools and Special Tools Tool Kit, Genl Mech (Item 46, Appendix C) Gun, Lubricating (Item 16, Appendix C)

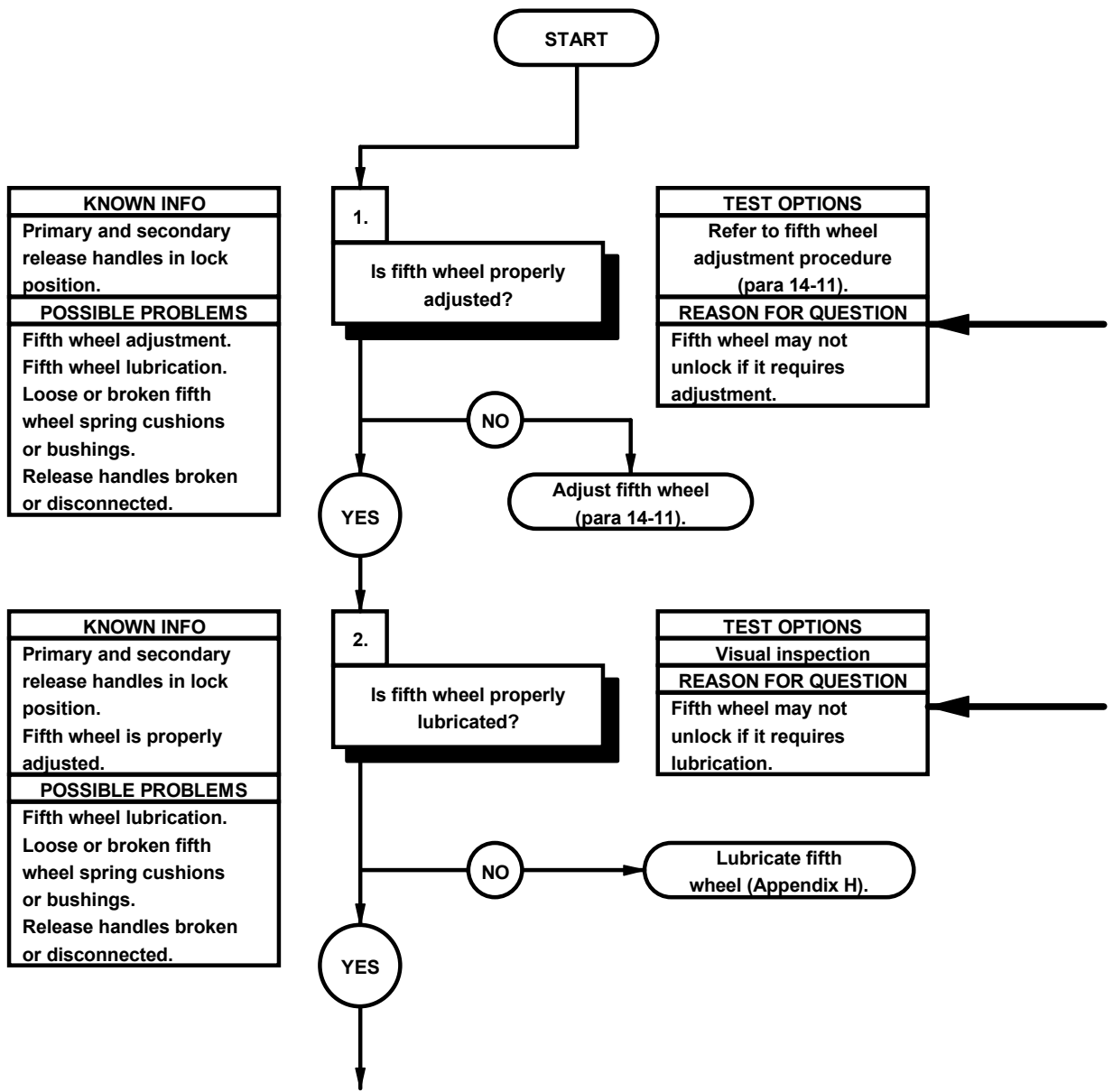

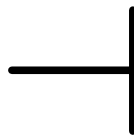

Refer to para 14-11 to check for proper fifth wheel adjustment.



Refer to Appendix H to lubricate fifth wheel.

q3. FIFTH WHEEL WILL NOT UNLOCK WHEN DISCONNECTING TRAILER FROM TRACTOR (CONT)

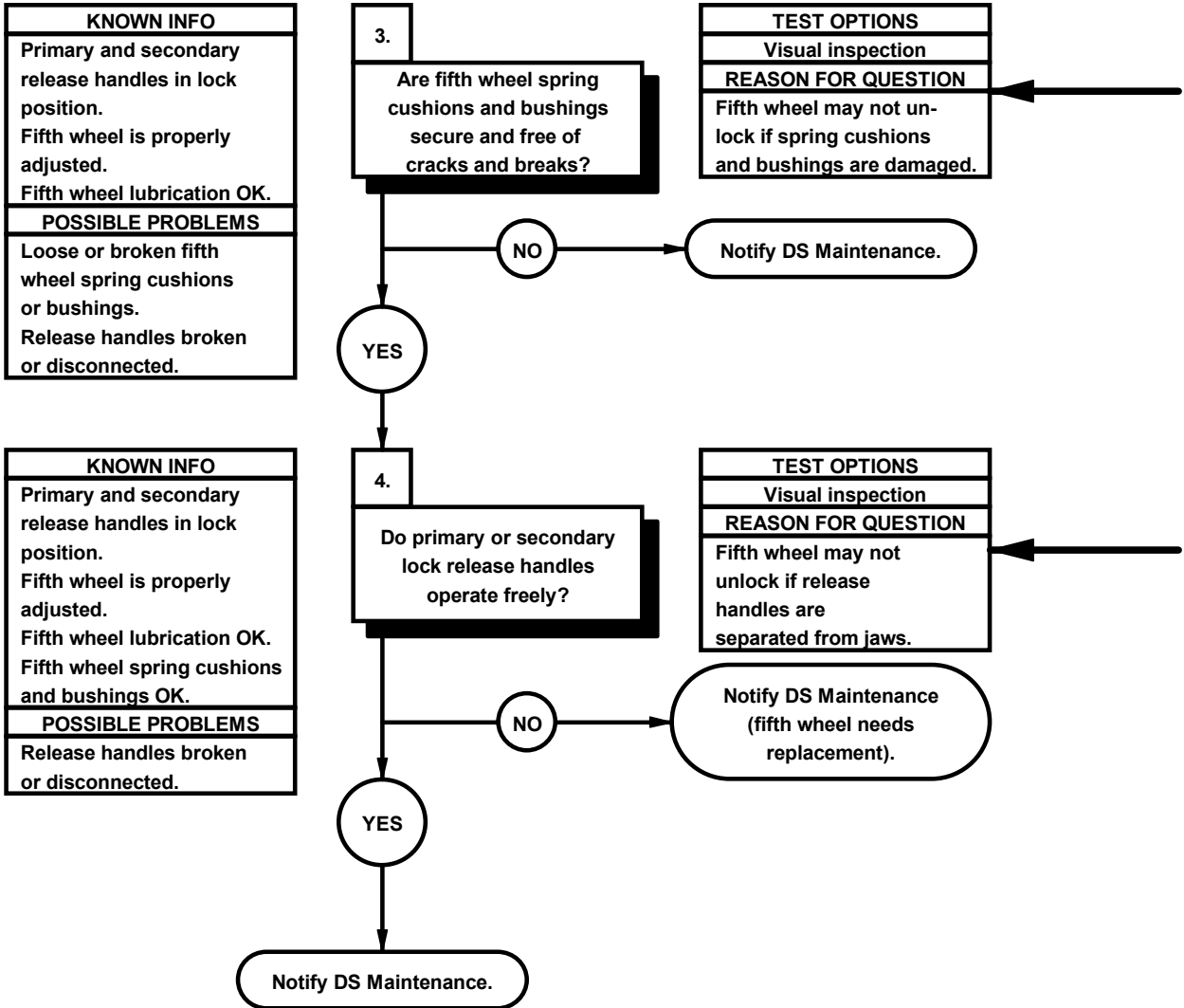

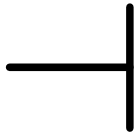

Check spring cushions and bushings in fifth wheel for looseness, cracks, or breaks.

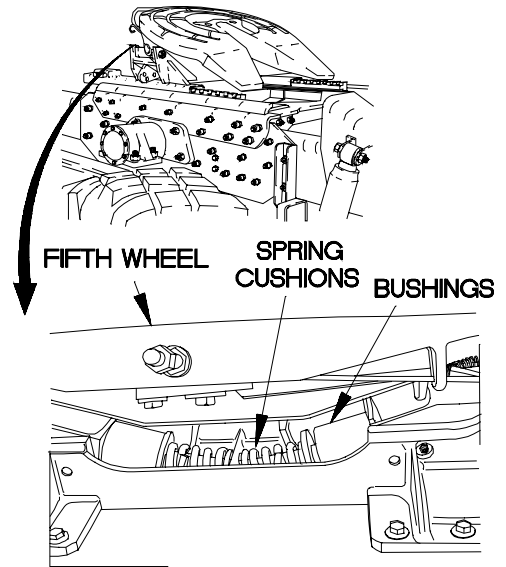

4200303A

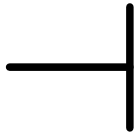

Attempt to perform trailer disconnect procedure (TM 9-2320-366-10-1).

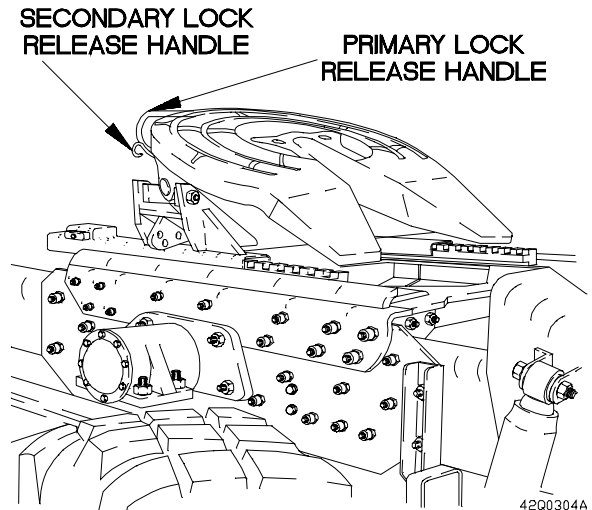

4200304A

q4. FIFTH WHEEL SLIDING MECHANISM DOES NOT OPERATE	
INITIAL SETUP	
Equipment Conditions Engine shut down (TM 9-2320-366-10-1).	Tools and Special Tools Tool Kit, Genl Mech (Item 46, Appendix C)

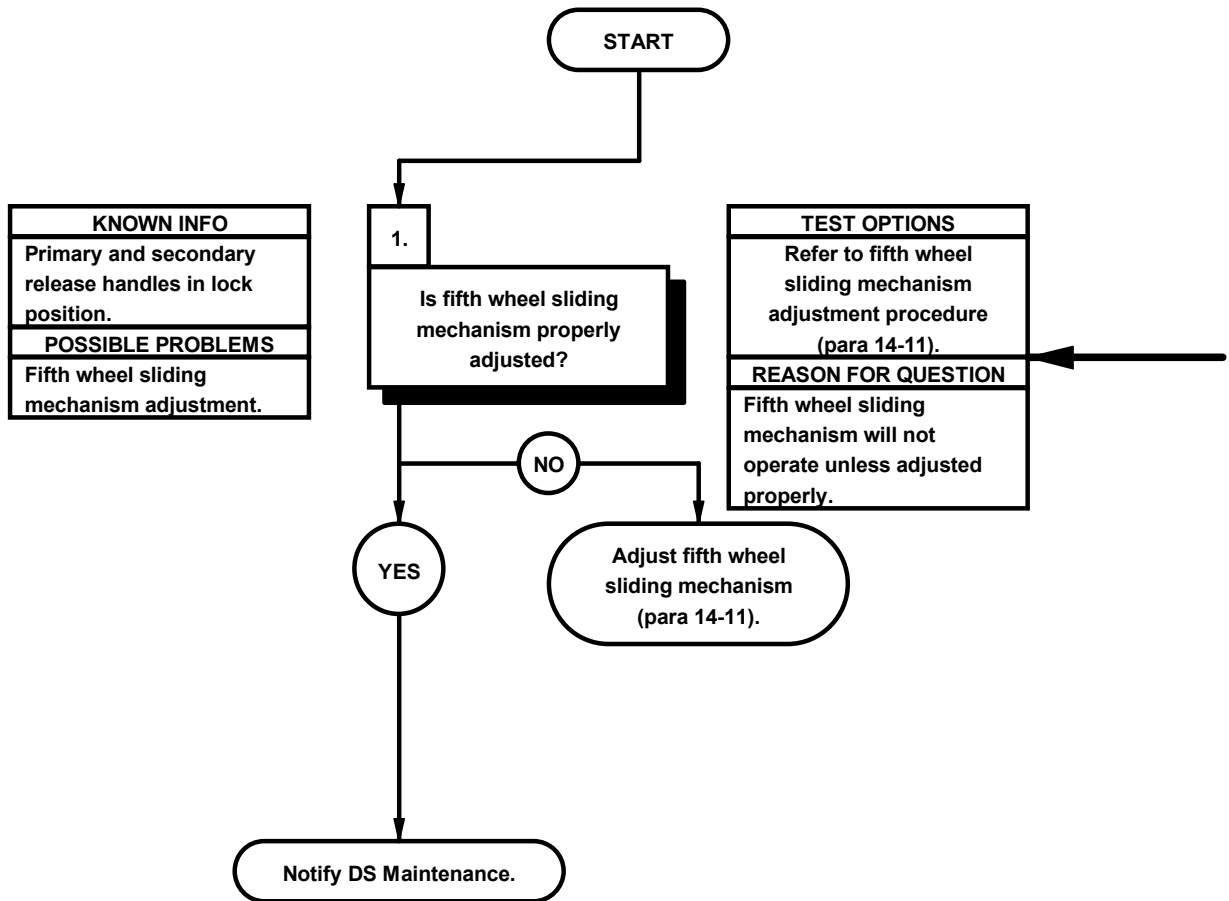

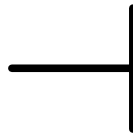

Refer to para 14-11 to check for proper fifth wheel sliding mechanism adjustment.

2-28. SUSPENSION SYSTEM TROUBLESHOOTING

This paragraph covers Suspension System Troubleshooting. The Suspension System Fault Index, Table 2-56, lists faults for the Suspension System of the vehicle.

Table 2-56. Suspension System Fault Index

Fault No.	Description	Page
r1.	Wanders, Pulls to One Side, or Shimmies	2-2190
r2.	Leans to One Side or Rear of Vehicle Sags	2-2200

r1. WANDERS, PULLS TO ONE SIDE, OR SHIMMIES	
INITIAL SETUP	
Equipment Conditions Engine shut down (TM 9-2320-366-10-1).	Tools and Special Tools Tool Kit, Genl Mech (Item 46, Appendix C) Iron, Tire (Item 20, Appendix C)

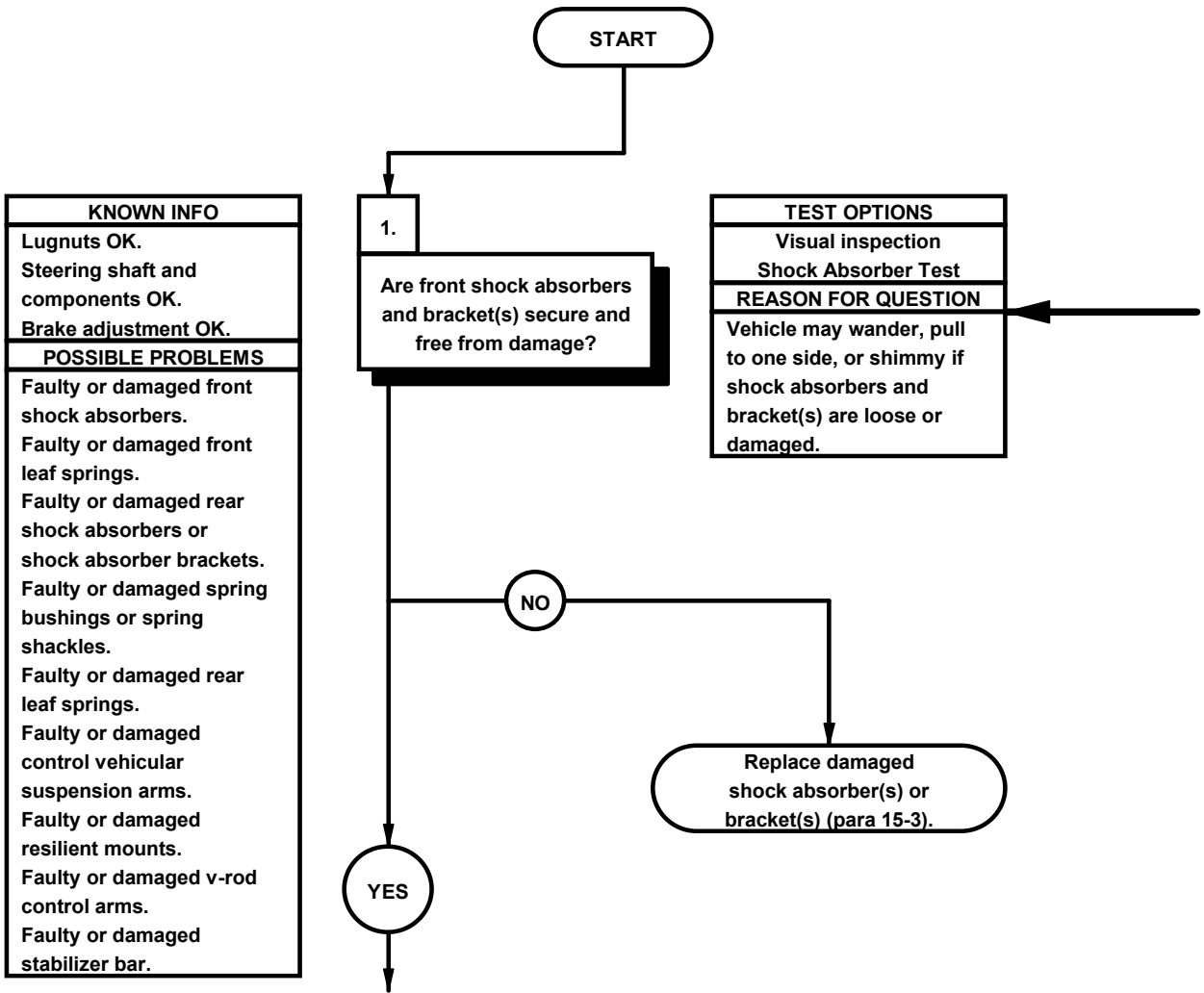

NOTE

Perform Steering System Troubleshooting (p2, Wanders, Pulls To One Side, Or Shimmies) before starting the steps given below.

- (1) Check shock absorbers for damage or leaks, and for missing mounting hardware.
- (2) Check shock absorbers bushings for movement.
- (3) Check shock absorber brackets for damage and for missing mounting hardware.

SHOCK ABSORBER TEST

- (1) Grasp shock absorber and ensure there is not excessive play.
- (2) Replace worn bushings.

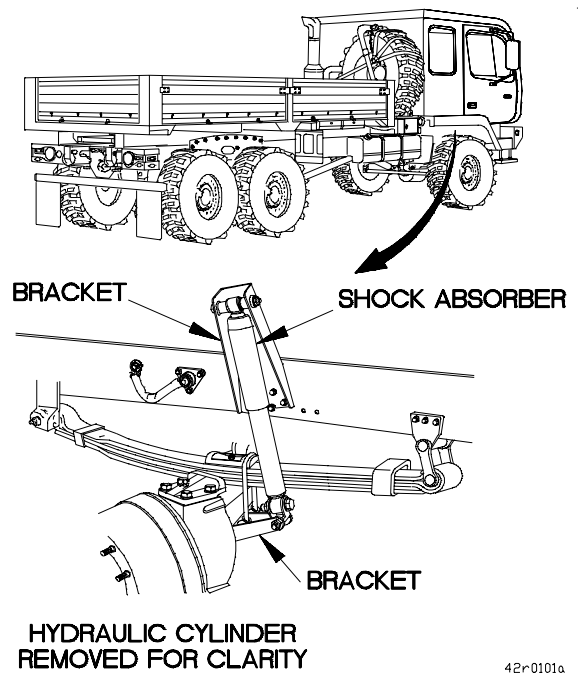

42r0101a

r1. WANDERS, PULLS TO ONE SIDE, OR SHIMMIES (CONT)

KNOWN INFO
Lugnuts OK. Steering shaft and components OK. Brake adjustment OK. Front shock absorbers OK.
POSSIBLE PROBLEMS
Faulty or damaged front leaf springs. Faulty or damaged rear shock absorbers or shock absorber brackets. Faulty or damaged spring bushings or spring shackles. Faulty or damaged rear leaf springs. Faulty or damaged control vehicular suspension arms. Faulty or damaged resilient mounts. Faulty or damaged v-rod control arms. Faulty or damaged stabilizer bar.

2.
Are front leaf springs secure and free from damage?

TEST OPTIONS
Visual inspection
REASON FOR QUESTION
Vehicle may wander, pull to one side, or shimmy if leaf springs are loose or damaged.

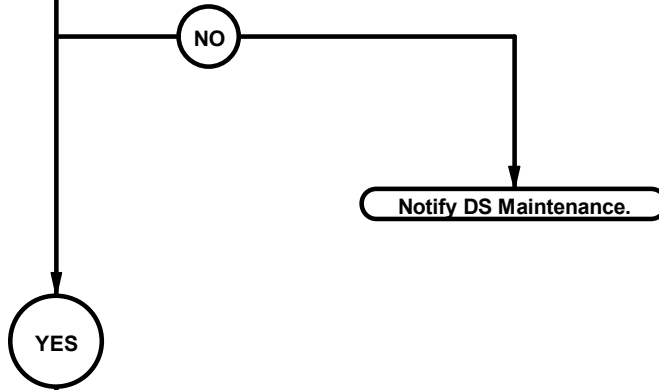

KNOWN INFO
Lugnuts OK. Steering shaft and components OK. Brake adjustment OK. Front shock absorbers OK. Front leaf springs OK.
POSSIBLE PROBLEMS
Faulty or damaged spring bushings or spring shackles. Faulty rear shock absorbers and shock absorber brackets. Faulty or damaged rear leaf springs. Faulty or damaged control vehicular suspension arms. Faulty or damaged resilient mounts. Faulty or damaged v-rod control arms. Faulty or damaged stabilizer bar.

3.
Are spring shackles and spring bushings secure and free from damage?

TEST OPTIONS
Visual inspection
Spring Shackle/Bushing Test
REASON FOR QUESTION
Vehicle may wander, pull to one side, or shimmy if spring shackles and spring bushings are loose or damaged.

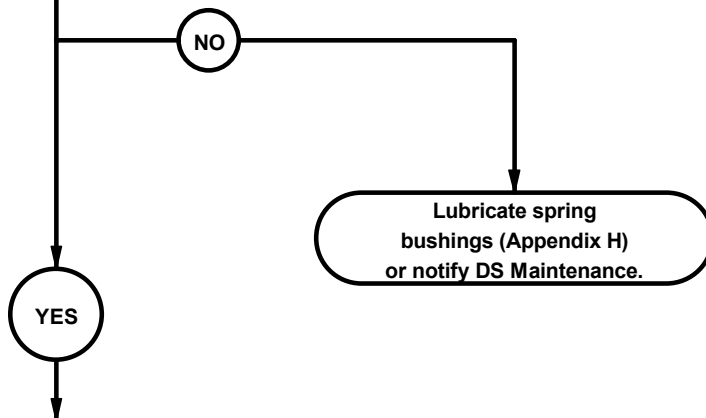

- (1) Check leaf springs for cracked or broken leaves or missing spring clips and U-bolts.
- (2) Check seats for looseness or damage.

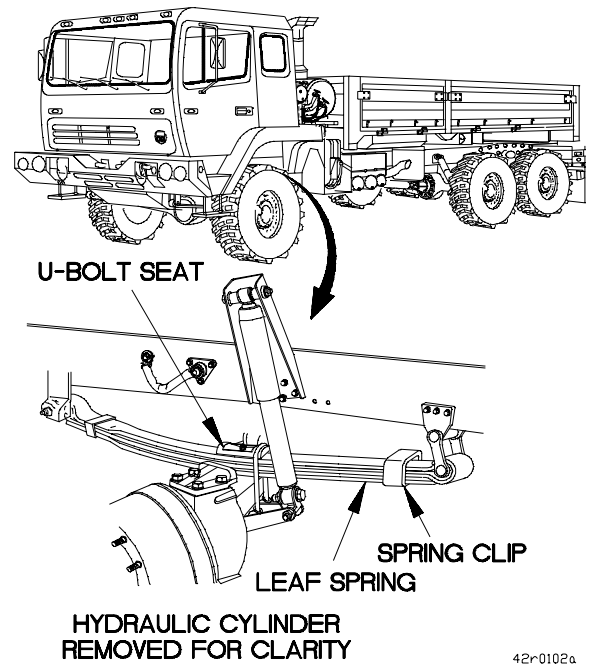

42r0102a

Check spring shackles and spring bushings for damage and for missing mounting hardware. Refer to Appendix H for lubrication of spring bushings.

SPRING SHACKLE/BUSHING TEST

- (1) Position tire iron between spring assembly and frame.
- (2) Pry up and down and ensure there is no movement.
- (3) Shackles or bushings are damaged if movement occurs.

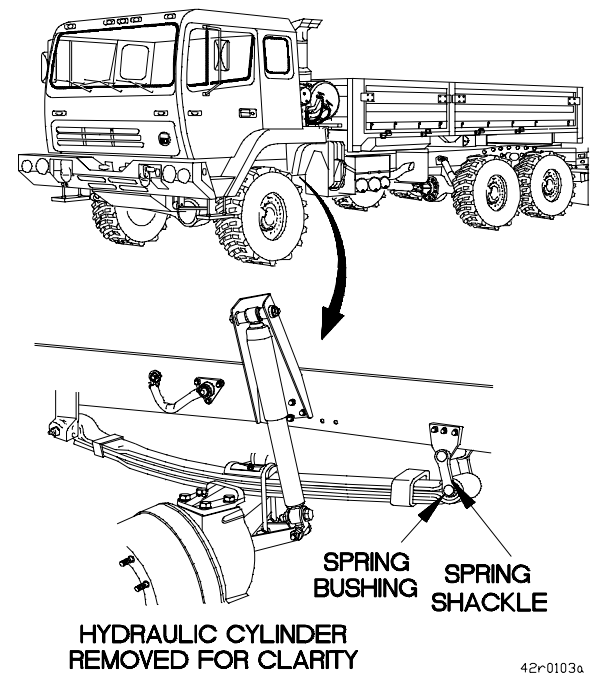

42r0103a

r1. WANDERS, PULLS TO ONE SIDE, OR SHIMMIES (CONT)

KNOWN INFO
Lugnuts OK. Steering shaft and components OK. Brake adjustment OK. Front shock absorbers OK. Front leaf springs OK.
POSSIBLE PROBLEMS
Faulty or damaged spring bushings or spring shackles. Faulty rear shock absorbers and shock absorber brackets. Faulty or damaged rear leaf springs. Faulty or damaged control vehicular suspension arms. Faulty or damaged resilient mounts. Faulty or damaged v-rod control arms. Faulty or damaged stabilizer bar.

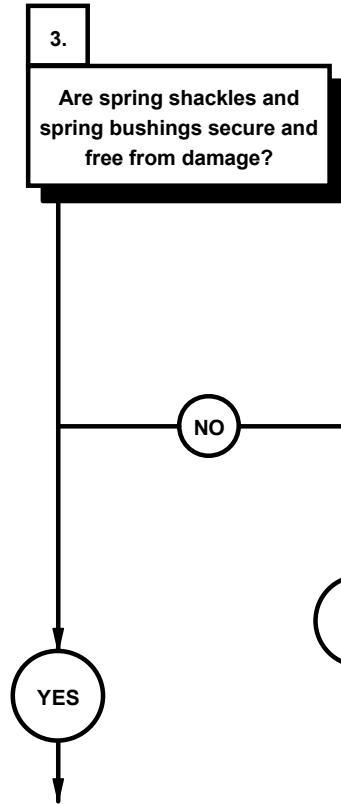

TEST OPTIONS
Visual inspection
Spring Shackle/Bushing Test
REASON FOR QUESTION
Vehicle may wander, pull to one side, or shimmy if spring shackles and spring bushings are loose or damaged.

Check spring shackles and spring bushings for damage and for missing mounting hardware. Refer to Appendix H for lubrication of spring bushings.

SPRING SHACKLE/BUSHING TEST

- (1) Position tire iron between spring assembly and frame.
- (2) Pry up and down and ensure there is no movement.
- (3) Shackles or bushings are damaged if movement occurs.

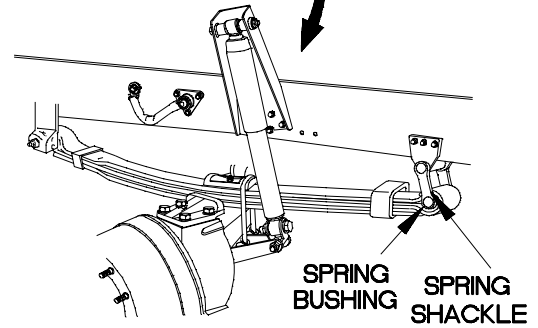
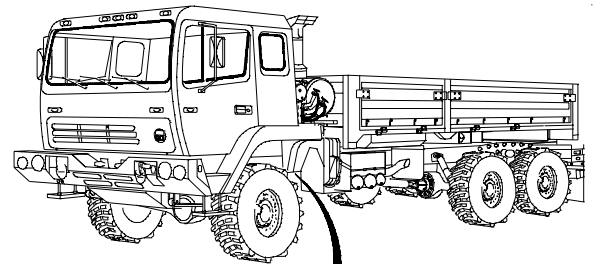

HYDRAULIC CYLINDER
REMOVED FOR CLARITY

42r0103a

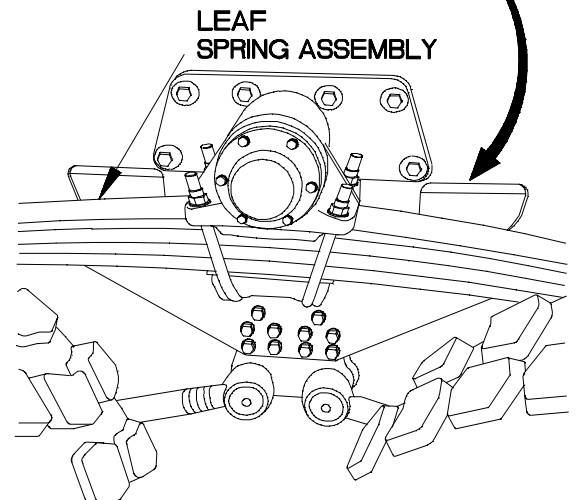
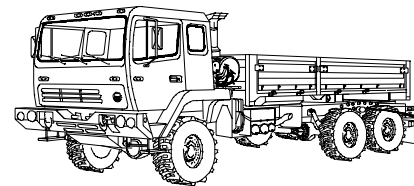

42r0105a

r1. WANDERS, PULLS TO ONE SIDE, OR SHIMMIES (CONT)

KNOWN INFO
Lugnuts OK. Steering shaft and components OK. Brake adjustment OK. Front shock absorbers OK. Front leaf springs OK. Spring bushings or spring shackles OK.
POSSIBLE PROBLEMS
Faulty or damaged rear shock absorbers or shock absorber brackets. Faulty or damaged rear leaf springs. Faulty or damaged control vehicular suspension arms. Faulty or damaged resilient mounts. Faulty or damaged v-rod control arms. Faulty or damaged stabilizer bar.

4.
Are rear shock absorbers and shock absorber brackets secure and free from damage?

TEST OPTIONS
Visual inspection
Shock Absorber Test
REASON FOR QUESTION
Vehicle may wander, pull to one side, or shimmy if shock absorber and shock absorber brackets are loose or damaged.

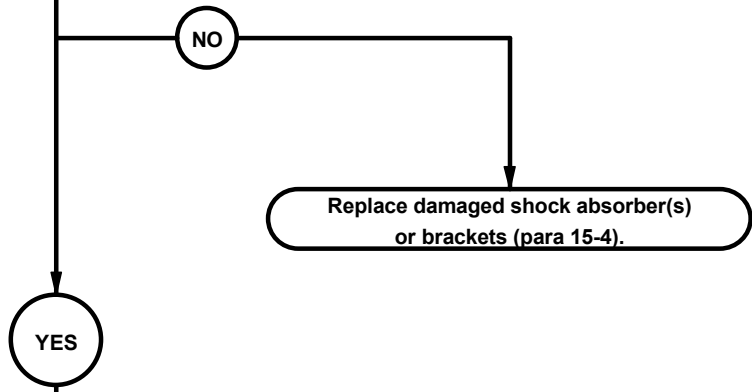

KNOWN INFO
Lugnuts OK. Steering shaft and components OK. Brake adjustment OK. Front shock absorbers OK. Front leaf springs OK. Rear shock absorbers and shock absorber brackets OK. Spring bushings and spring shackles OK.
POSSIBLE PROBLEMS
Faulty or damaged rear leaf springs. Faulty or damaged control vehicular suspension arms. Faulty or damaged resilient mounts. Faulty or damaged v-rod control arms. Faulty or damaged stabilizer bar.

5.
Are leaf springs secure and free from damage?

TEST OPTIONS
Visual inspection
REASON FOR QUESTION
Vehicle may wander, pull to one side, or shimmy if leaf springs are loose or damaged.

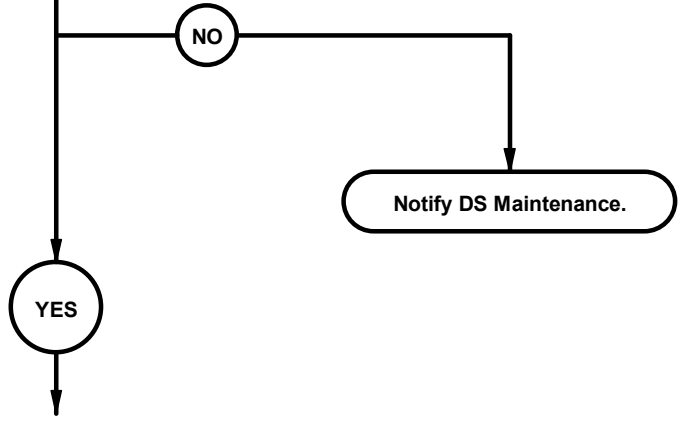

- (1) Check shock absorbers for damage or leaks, and for missing mounting hardware.
- (2) Check shock absorber brackets for damage and for missing mounting hardware.
- (3) Check shock absorber bushings for movement.

SHOCK ABSORBER TEST

- (1) Grasp shock absorber and ensure there is no excessive play.
- (2) Replace worn bushings.

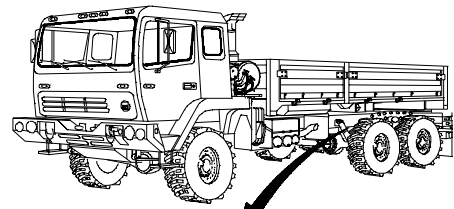

BRACKET SHOCK ABSORBER

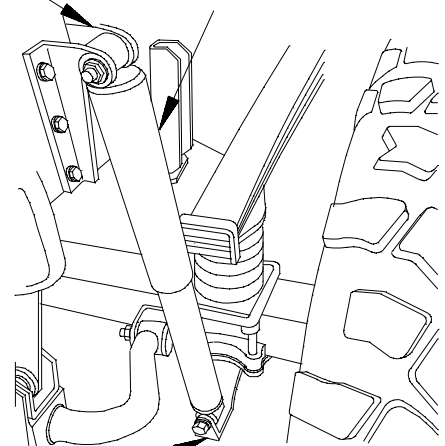

BRACKET

42R01061

Check rear leaf springs for damage and for missing mounting hardware.

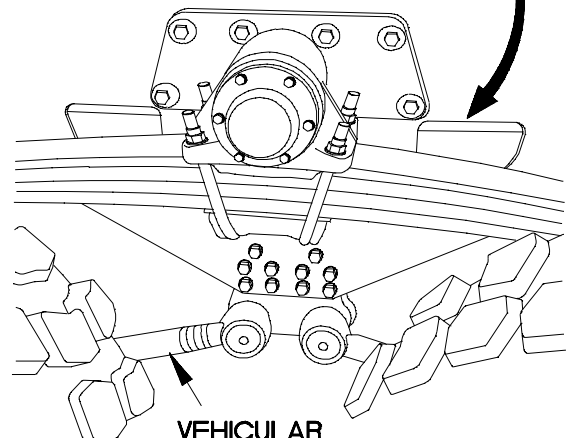
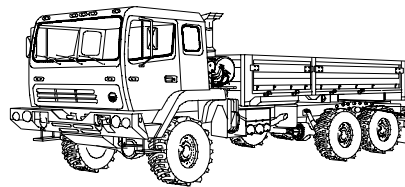

VEHICULAR
SUSPENSION
CONTROL ARM

42r0107a

r1. WANDERS, PULLS TO ONE SIDE, OR SHIMMIES (CONT)

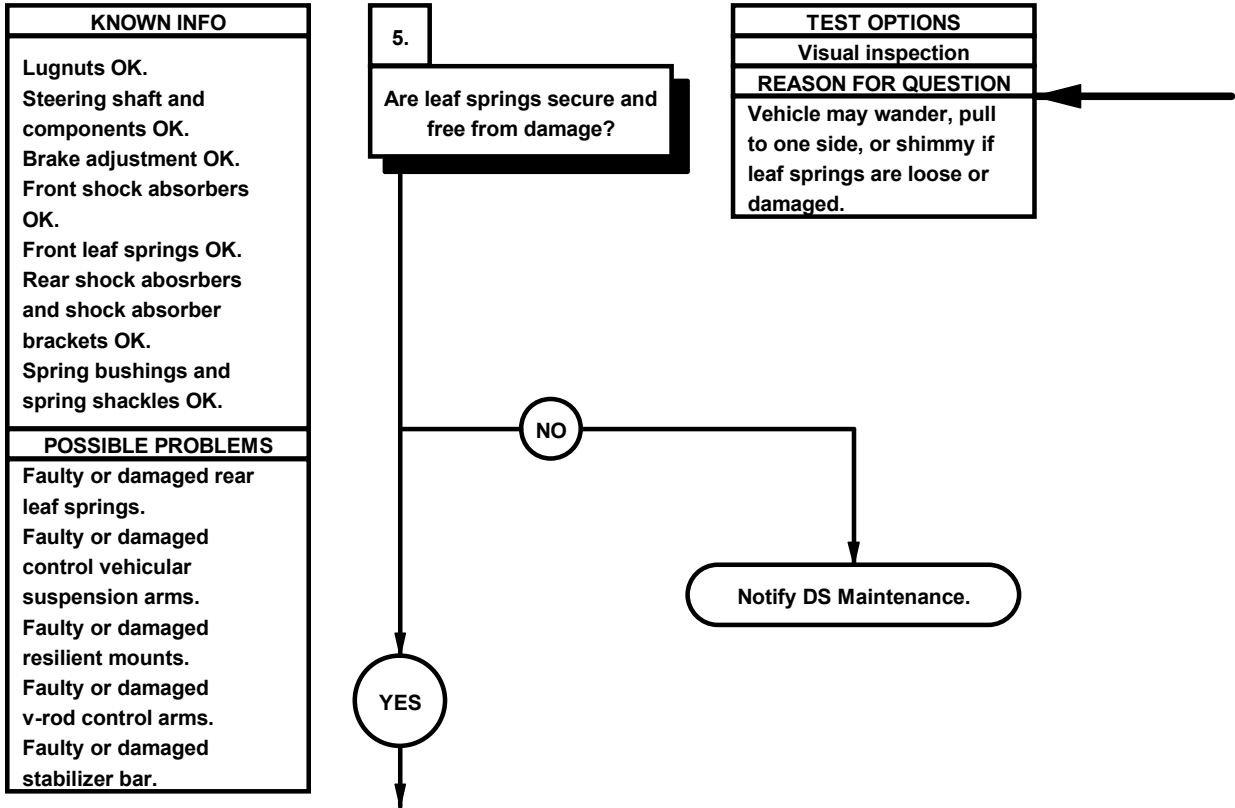

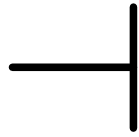

Check rear leaf springs for damage and for missing mounting hardware.

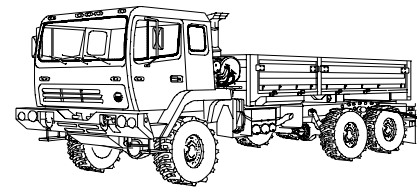

LEAF
SPRING ASSEMBLY

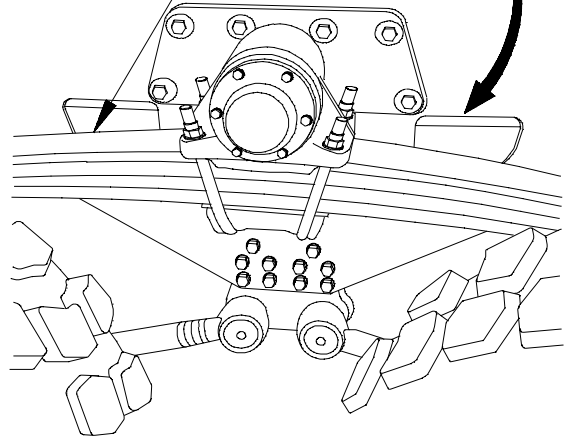

42R01081

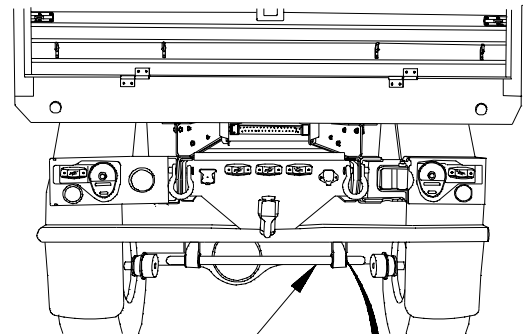

STABILIZER BAR

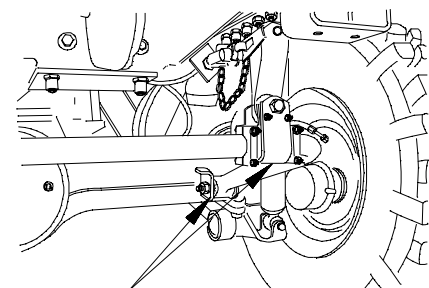

MOUNTS
AND
BUSHINGS

42r0109-

r2. LEANS TO ONE SIDE OR REAR OF VEHICLE SAGS

INITIAL SETUP

Equipment Conditions
 Engine shut down (TM 9-2320-366-10-1).

Tools and Special Tools
 Tool Kit, Genl Mech (Item 46, Appendix C)

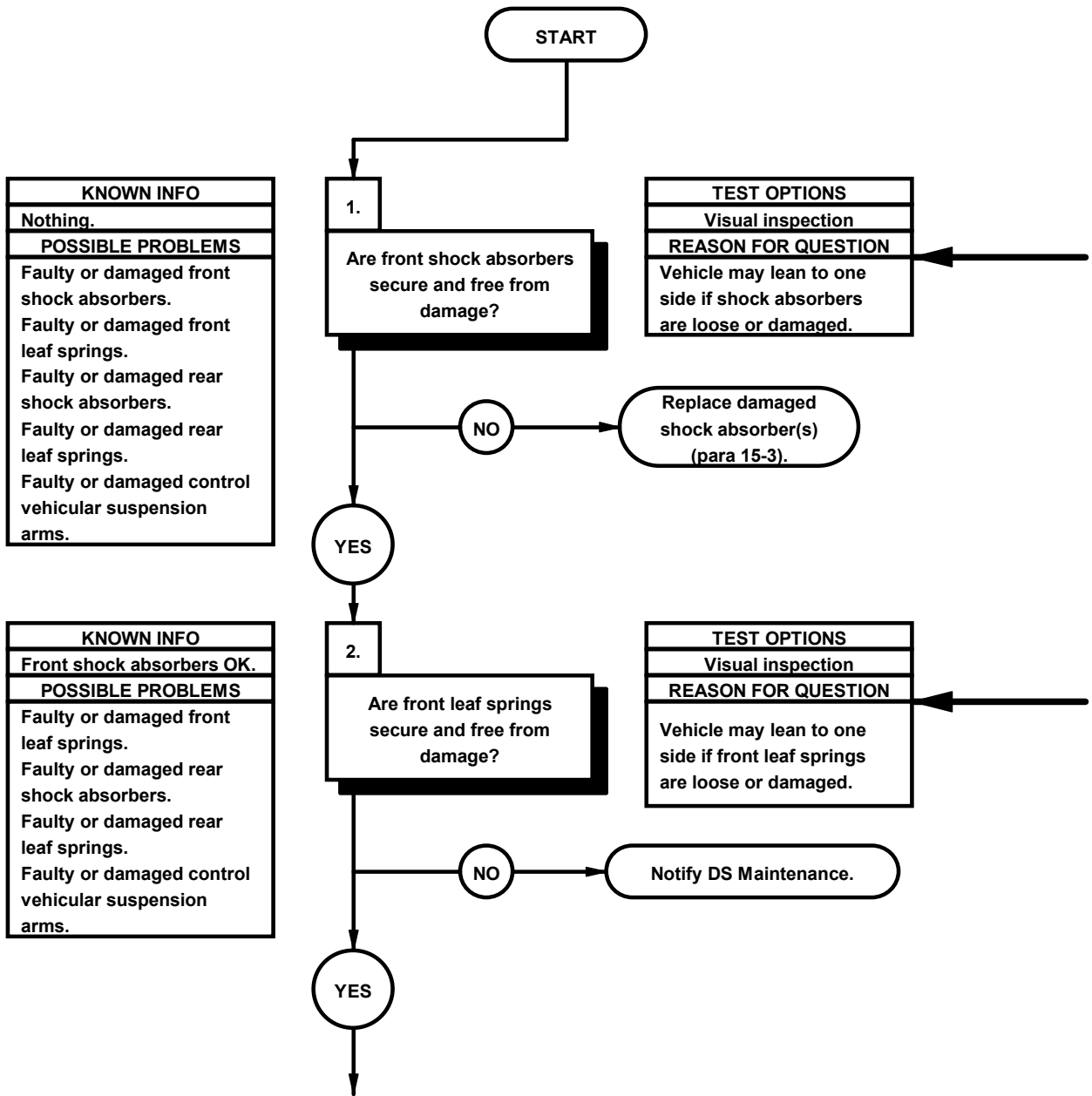

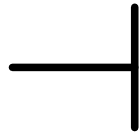

Check shock absorbers for damage or leaks, and for missing or cracked mounting hardware.

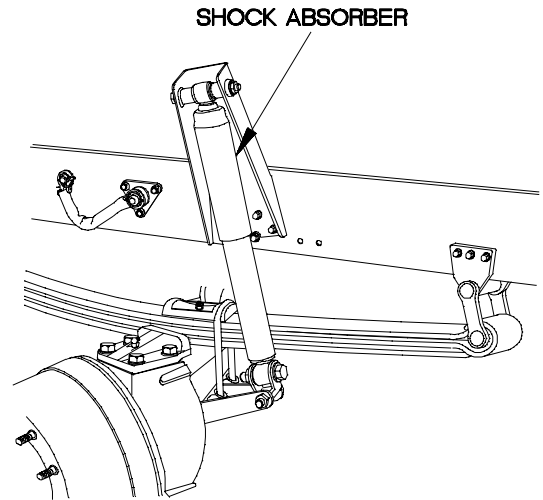

X2r-0201-

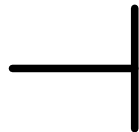

Check front leaf springs for damage and for loose or missing mounting hardware.

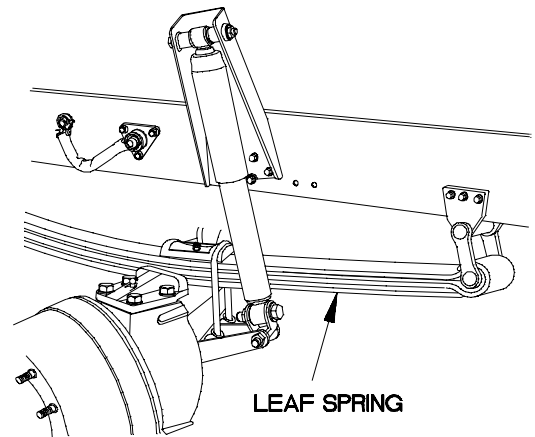

X2r-0202-

r2. LEANS TO ONE SIDE OR REAR OF VEHICLE SAGS (CONT)

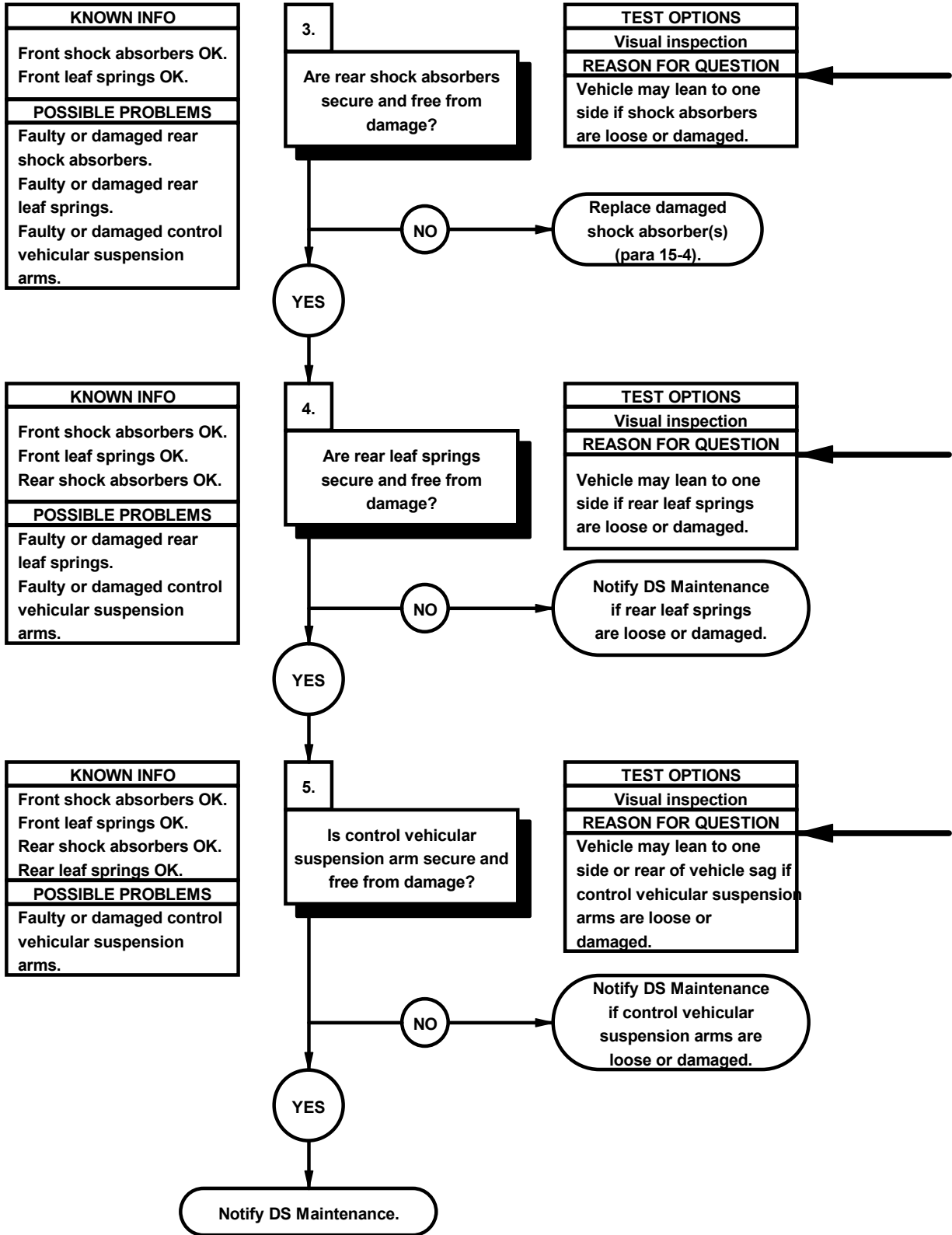

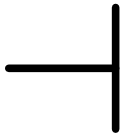

Check shock absorbers for damage or leaks, and for missing or cracked mounting hardware.

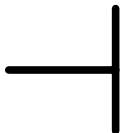
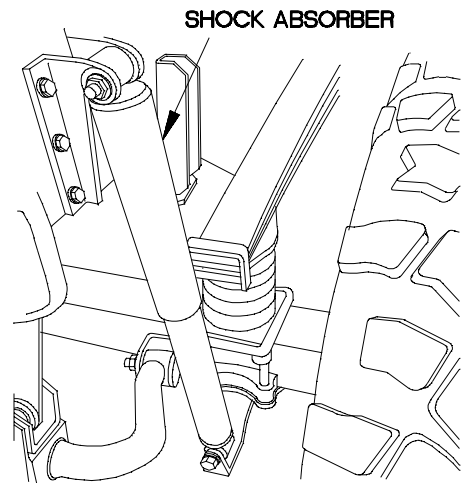

Check rear leaf springs for damage or leaks, and for missing mounting hardware.

42r0203-

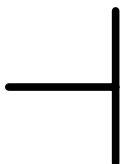

Check control vehicular suspension arms for damage or bushing failure, and for missing mounting hardware.

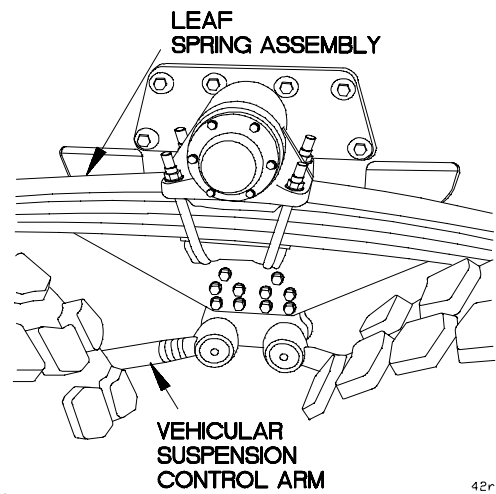

42r0204-

2-29. 15K SELF-RECOVERY WINCH (SRW) SYSTEM TROUBLESHOOTING

This paragraph covers 15K Self-Recovery Winch (SRW) System Troubleshooting. The 15K Self-Recovery Winch (SRW) System Fault Index, Table 2-57, lists faults for the 15K Self-Recovery Winch (SRW) system of the vehicle.

Table 2-57. 15K Self-Recovery Winch (SRW) System Fault Index

Fault No.	Description	Page
s1.	15K Self-Recovery Winch (SRW) Does Not Work	2-2206

s1. 15K SELF-RECOVERY WINCH DOES NOT WORK	
INITIAL SETUP	
Equipment Conditions Engine shut down (TM 9-2320-366-10-1).	Tools and Special Tools Tool Kit, Genl Mech (Item 46, Appendix C) STE/ICE-R (Item 41, Appendix C) Pan, Drain (Item 24, Appendix C) Transducer, STE/ICE-R (Item 1, Appendix J) Goggles, Industrial (Item 15, Appendix C)
Personnel Required (2)	Materials/Parts Rag, Wiping (Item 50, Appendix D)
References TM 9-4910-571-12&P	

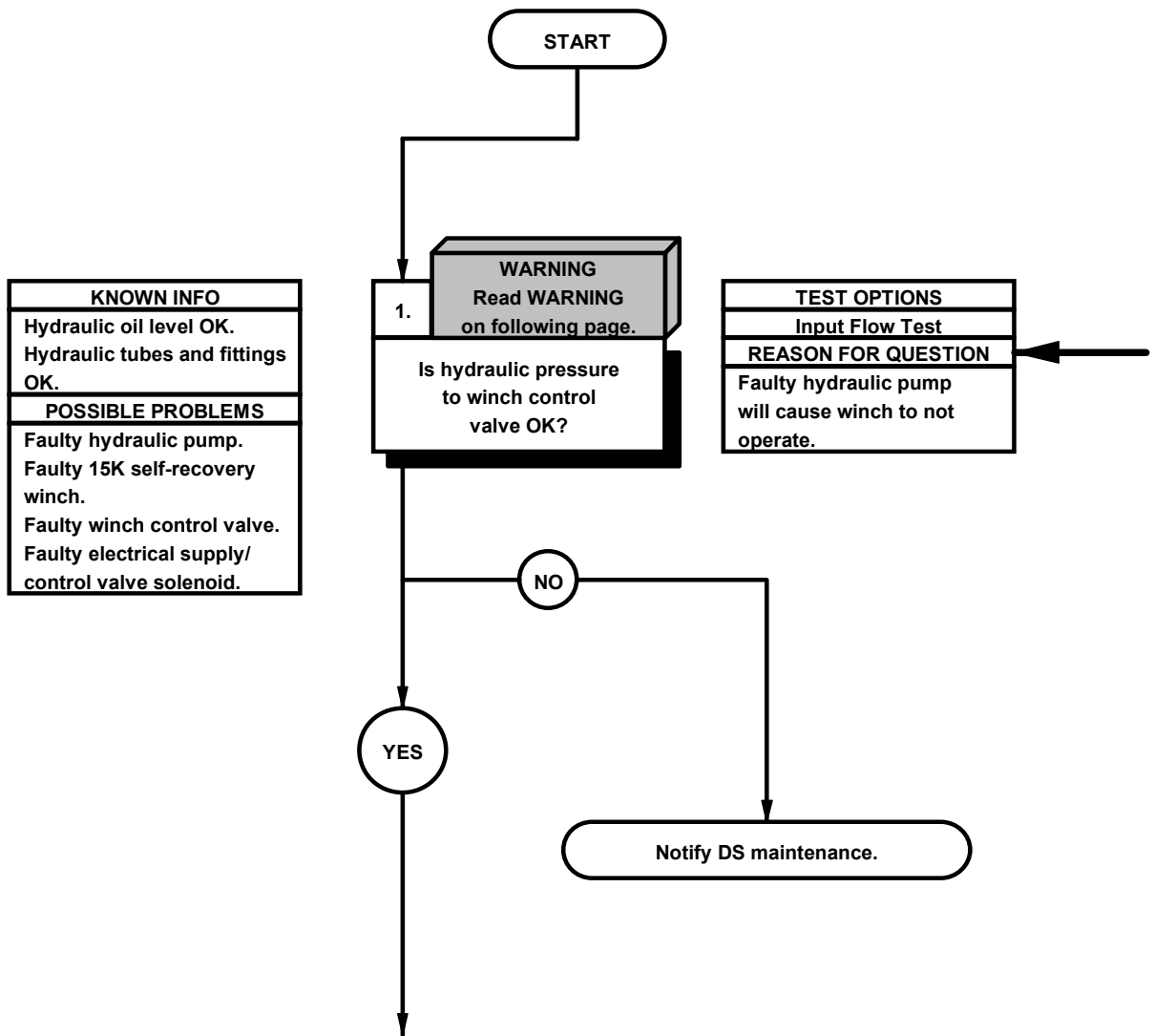

WARNING

- Drop hydraulic pressure to zero before disconnecting any hydraulic hoses, tubes or fittings. Failure to comply may result in injury to personnel.
- Wear approved eye protection when performing pressure checks. Failure to comply may result in oil getting into eyes. If oil contacts eyes, seek medical attention immediately.
- Fuel and oil are slippery and can cause falls. Wipe up spilled fuel or oil with rags. Failure to comply may result in injury to personnel.

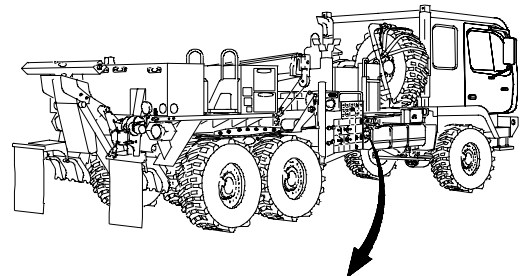

INPUT FLOW TEST

- (1) Place drain pan under control valve.
- (2) Disconnect hose from port P of winch control valve.
- (3) Connect STE/ICE-R with 5/8 in. tee and adapter kit between hose fitting and port P.
- (4) Start engine (TM 9-2320-366-10-1).
- (5) Position PTO switch to on (TM 9-2320-366-10-1).
- (6) Attach stall load to winch cable (TM 9-2320-366-10-1).
- (7) Position WINCH POWER switch to on (TM 9-2320-366-10-1).
- (8) Engage winch clutch (TM 9-2320-366-10-1).
- (9) Toggle WINCH IN/OUT switch to IN (TM 9-2320-366-10-1) and perform STE/ICE-R test #51 (TM 9-4910-574-12&P) and note pressure reading.
- (10) Check if pressure is between 2450-2600 psi (16893-17927 kPa), if pressure is lower than 2450 psi, notify DS Maintenance.
- (11) Position WINCH POWER and PTO switches to off (TM 9-2320-366-10-1).
- (12) Shut down engine (TM 9-2320-366-10-1).
- (13) Disconnect STE/ICE-R, tee, and adapter kit.
- (14) Connect hose fitting to port P.
- (15) Remove drain pan.

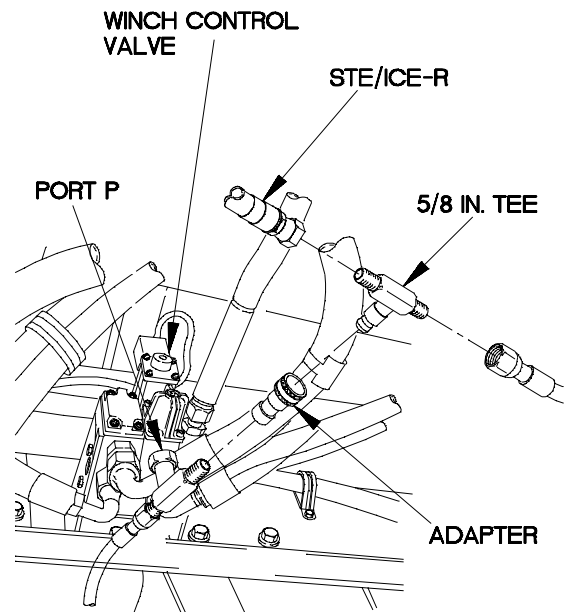

42s0101a

s1. 15K SELF-RECOVERY WINCH DOES NOT WORK (CONT)

KNOWN INFO
Hydraulic oil level OK.
Hydraulic tubes and fittings OK.
Hydraulic pump OK.
POSSIBLE PROBLEMS
Faulty 15K self-recovery winch.
Faulty winch control valve.
Faulty electrical supply/ control valve solenoid.

2.
Is pressure absent or 2450-2600 psi (16893-17927 kPa) at V1 and/or V2 on 15K self-recovery winch?

TEST OPTIONS
Winch Control Valve Pressure Test
REASON FOR QUESTION
Faulty winch control valve will cause 15K self-recovery winch not to operate due to low or absent hydraulic pressure.

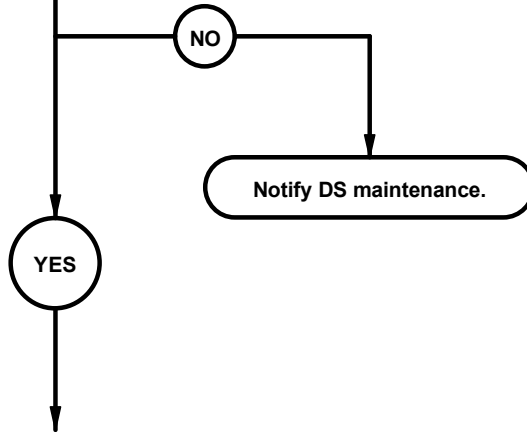

WINCH CONTROL VALVE PRESSURE TEST

- (1) Disconnect hose from fitting below elbow at port V1 (on side of 15K self-recovery winch toward front of vehicle).
- (2) Connect STE/ICE-R with tee between port V1 and hose.
- (3) Start engine (TM 9-2320-366-10-1).
- (4) Attach stall load to winch cable (TM 9-2320-366-10-1).
- (5) Position PTO switch and WINCH POWER switch to ON (TM 9-2320-366-10-1).
- (6) Engage winch clutch (TM 9-2320-366-10-1).
- (7) Perform STE/ICE-R test #51 and toggle WINCH IN/OUT switch to IN position and hold (TM 9-4910-571-12&P).
- (8) Check if pressure reading is between 2450-2600 psi (16893-17927 kPa) on STE/ICE-R.
- (9) If pressure is less than 2600 psi, notify DS Maintenance.
- (10) Position WINCH POWER and PTO switches to off (TM 9-2320-366-10-1).
- (11) Shut down engine (TM 9-2320-366-10-1).
- (12) Disconnect STE/ICE-R and tee.
- (13) Connect hose fitting to port V1.
- (14) Disconnect hose (below elbow) from port V2.
- (15) Connect STE/ICE-R with tee between hose and port V2.
- (16) Start engine (TM 9-2320-366-10-1).
- (17) Position PTO and WINCH POWER switches to on (TM 9-2320-366-10-1).
- (18) Perform STE/ICE-R test #51 and toggle WINCH IN/OUT switch to OUT (TM 9-4910-571-12&P).
- (19) Check if pressure reading is between 2450-2600 psi (16893-17927 kPa).
- (20) If pressure is lower than 2450 psi, notify DS Maintenance.
- (21) Release load and retrieve cable (TM 9-2320-366-10-1).
- (22) Position WINCH POWER and PTO switches to off (TM 9-2320-366-10-1).
- (23) Disengage winch clutch (TM 9-2320-366-10-1).
- (24) Shut down engine (TM 9-2320-366-10-1).
- (25) Disconnect STE/ICE-R and tee.
- (26) Connect hose fitting to port V2.

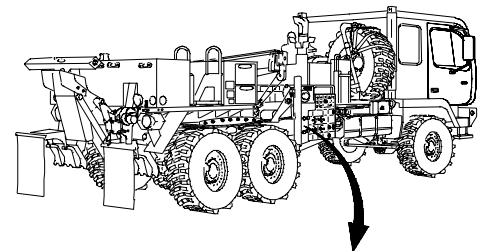
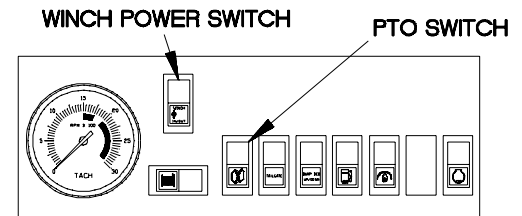
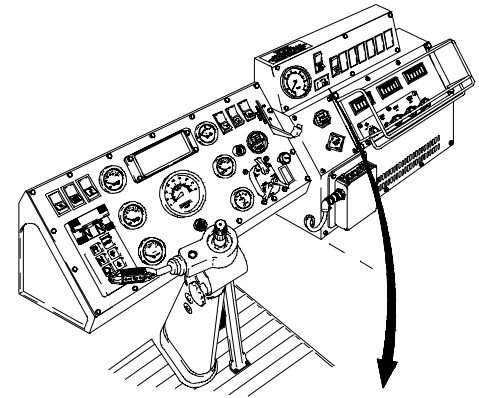

INSERT STE/ICE EQUIPMENT HERE FOR PRESSURE TEST AT V1

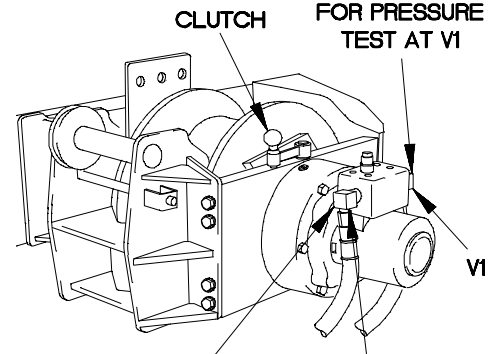

INSERT STE/ICE EQUIPMENT HERE FOR PRESSURE TEST AT V2

42s0102a

s1. 15K SELF-RECOVERY WINCH DOES NOT WORK (CONT)

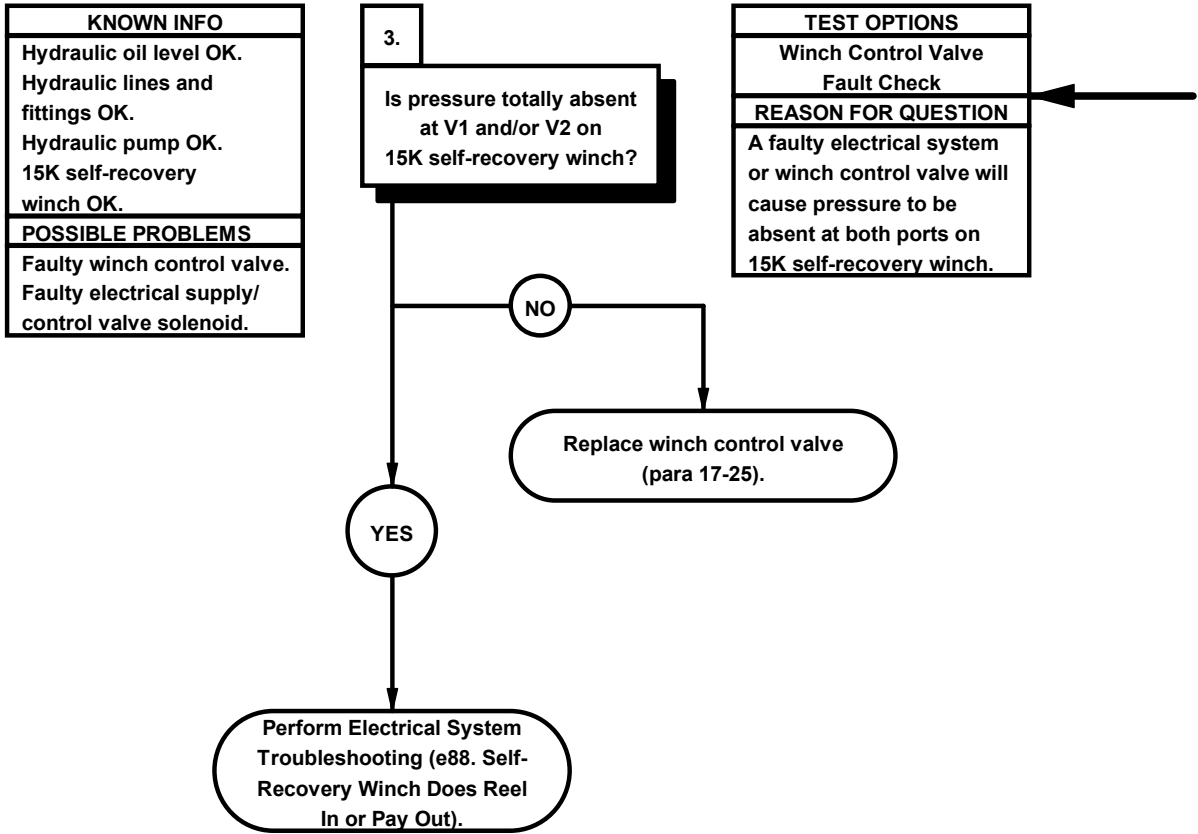

WINCH CONTROL VALVE FAULT CHECK

- (1) If hydraulic pressure was absent in winch control valve pressure test (step 2.), perform electrical system troubleshooting (e88. 15K Self-Recovery Winch Does Not Reel In or Pay Out).
- (2) If hydraulic pressure was low in winch control valve pressure test (step 2.), replace winch control valve (para 17-25).

2-30. STEERING HYDRAULIC SYSTEM TROUBLESHOOTING

This paragraph covers Steering Hydraulic System Troubleshooting. The Steering Hydraulic System Fault Index, Table 2-58, lists faults for the Steering Hydraulic System of the vehicle.

Table 2-58. Steering Hydraulic System Fault Index

Fault No.	Description	Page
t1.	Steering Hard or Does Not Work	2-2214

t1. STEERING HARD OR DOES NOT WORK	
INITIAL SETUP	
Equipment Conditions Engine shut down (TM 9-2320-366-10-1).	Tools and Special Tools Tool Kit, Genl Mech (Item 46, Appendix C) Goggles, Industrial (Item 15, Appendix C)
Personnel Required (2)	Materials/Parts Rag, Wiping (Item 50, Appendix D)

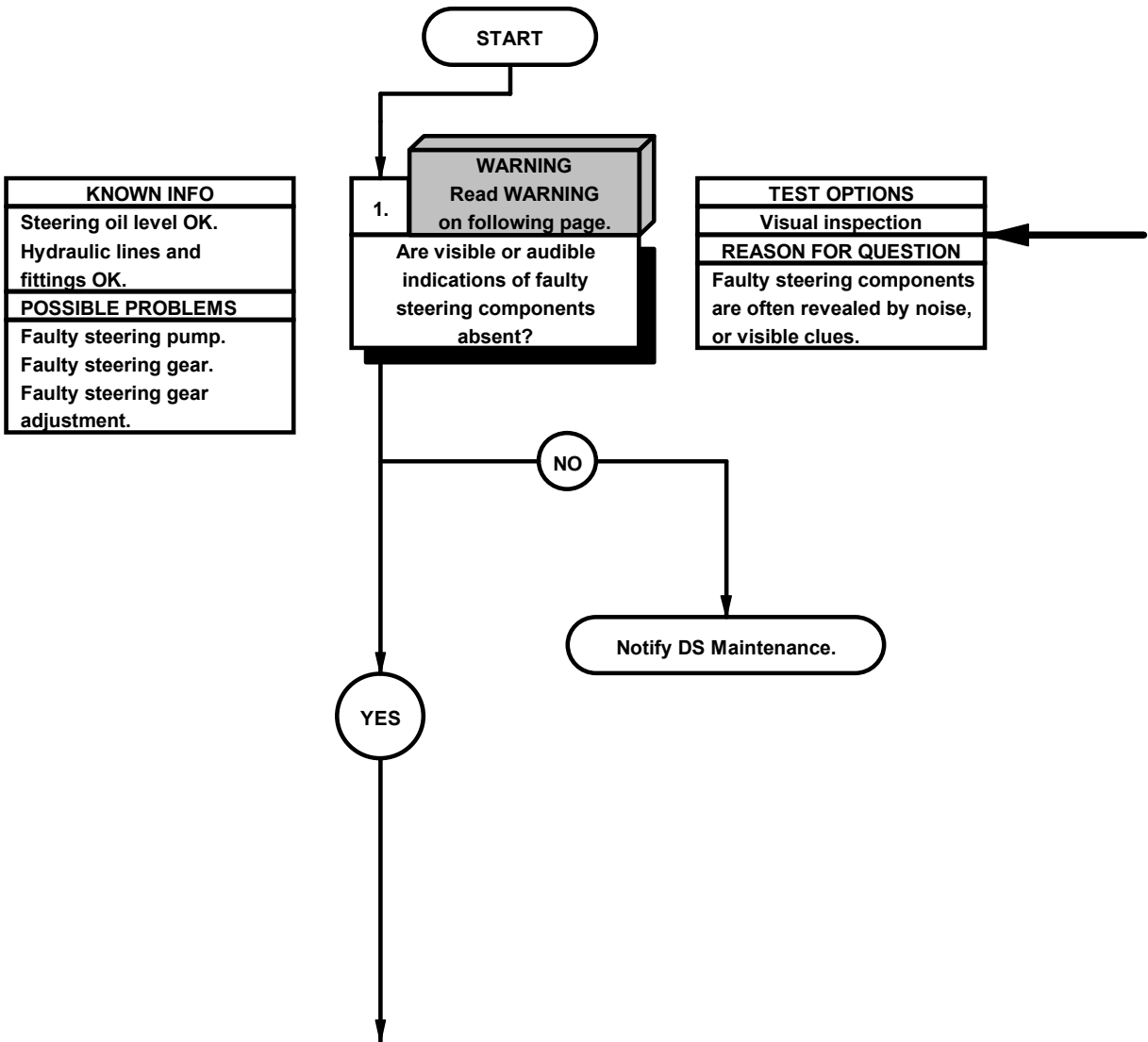

WARNING

- Drop hydraulic pressure to zero before disconnecting any hydraulic line. Failure to comply may result in injury to personnel.
- Wear approved eye protection when performing pressure checks. Failure to comply may result in oil getting into eyes. If oil contacts eyes, seek medical attention immediately.
- Fuel and oil are slippery and can cause falls. Wipe up spilled fuel or oil with rags. Failure to comply may result in injury to personnel.

- (1) Check steering oil level and fill as required (Appendix H).
- (2) Start engine (TM 9-2320-366-10-1).
- (3) Turn steering wheel from lock-to-lock.
- (4) Listen for unusual sounds. Faulty steering pump or steering gear may be noisy.
- (5) Shut down engine (TM 9-2320-366-10-1).

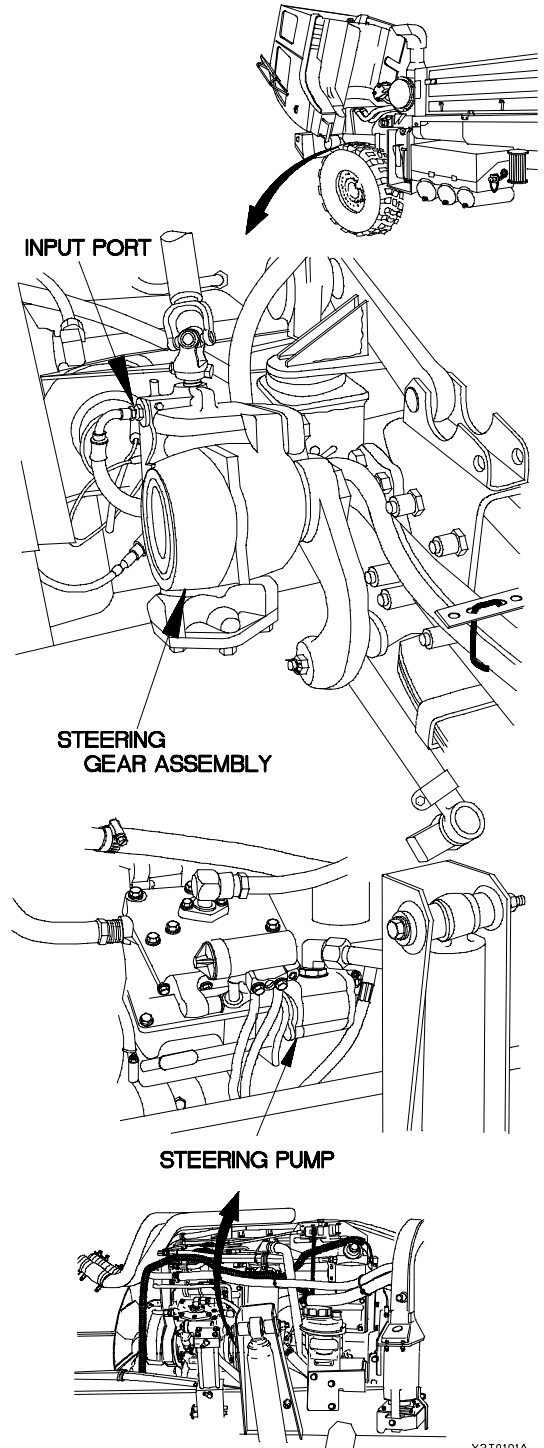

X2T0101A

t1. STEERING HARD OR DOES NOT WORK (CONT)

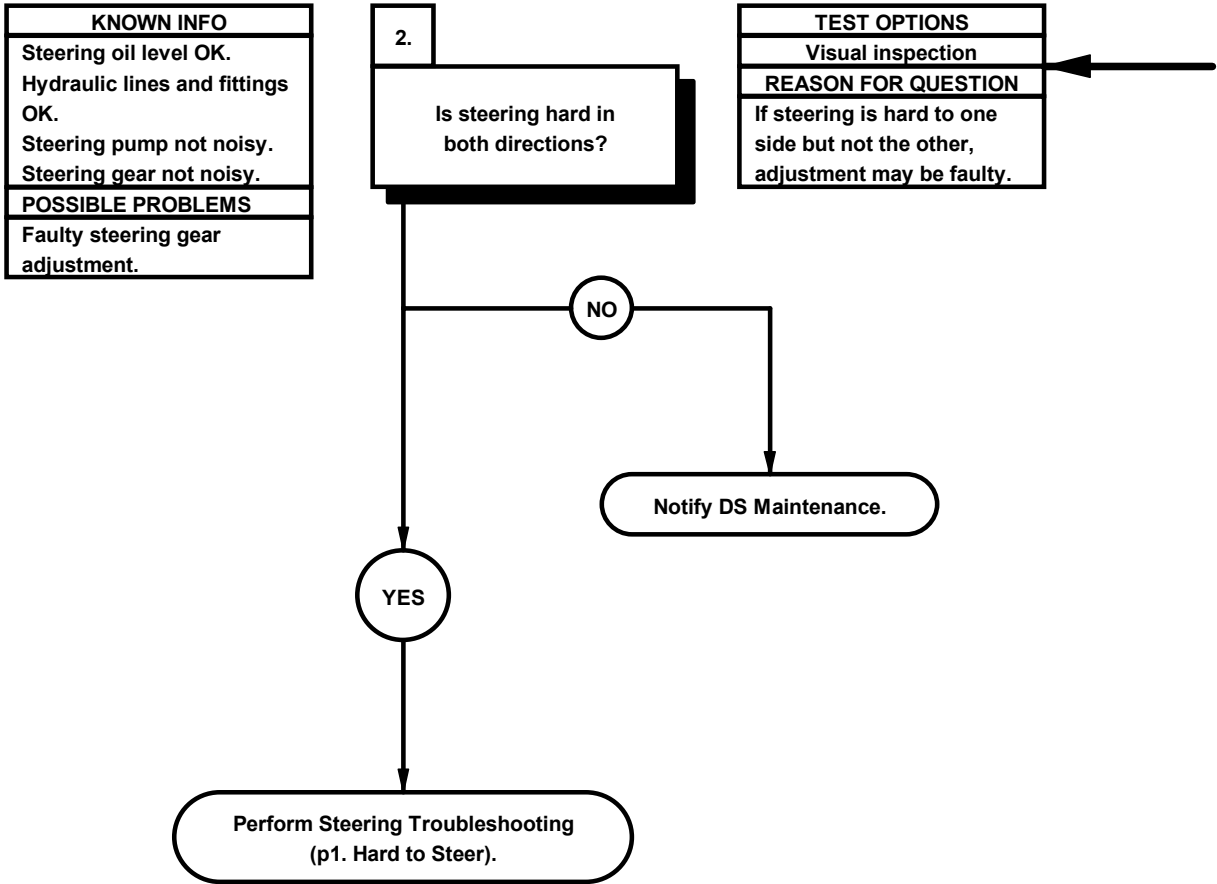

- (1) Raise cab (TM 9-2320-366-10-1).
- (2) Inspect point on each end of front axle housing where wheel stop contacts axle. If this spot is gouged or peened or if steering is harder in one direction than the other, steering adjustment may be faulty.
- (3) Lower cab (TM 9-2320-366-10-1).

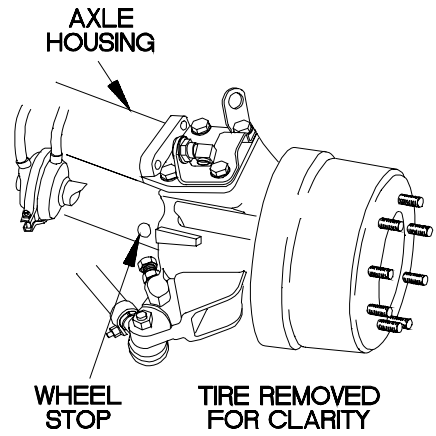

X2T0102-

2-31. AIR TRANSPORT TROUBLESHOOTING

This paragraph covers Air Transport Components Troubleshooting. The Air Transport Components Fault Index, Table 2-59, lists faults for the Air Transport Components of the vehicle.

Table 2-59. Air Transport Components Fault Index

Fault No.	Description	Page
u1.	Cab Tilt, Spare Tire Retainer, and Suspension Compression Do Not Operate	2-2220
u2.	Suspension Does Not Compress or Return to Normal	2-2230
u3.	Cab Leveling Air Springs Do Not Operate	2-2232

u1. CAB TILT, SPARE TIRE RETAINER, AND SUSPENSION COMPRESSION DO NOT OPERATE

INITIAL SETUP

Equipment Condition

Engine shut down (TM 9-2320-366-10-1).

Personnel Required

(2)

Material/Parts

Filter Assembly (2) (Item 14, Appendix G)
Rag, Wiping (Item 50, Appendix D)



Tools and Special Tools

Tool Kit, Genl Mech (Item 46, Appendix C)
STE/ICE-R (Item 41, Appendix C)
Pan, Drain (Item 24, Appendix C)
Goggles, Industrial (Item 15, Appendix C)
Transducer, 10,000 PSI (Item 1, Appendix J)
Gloves, Rubber (Item 13, Appendix C)

References

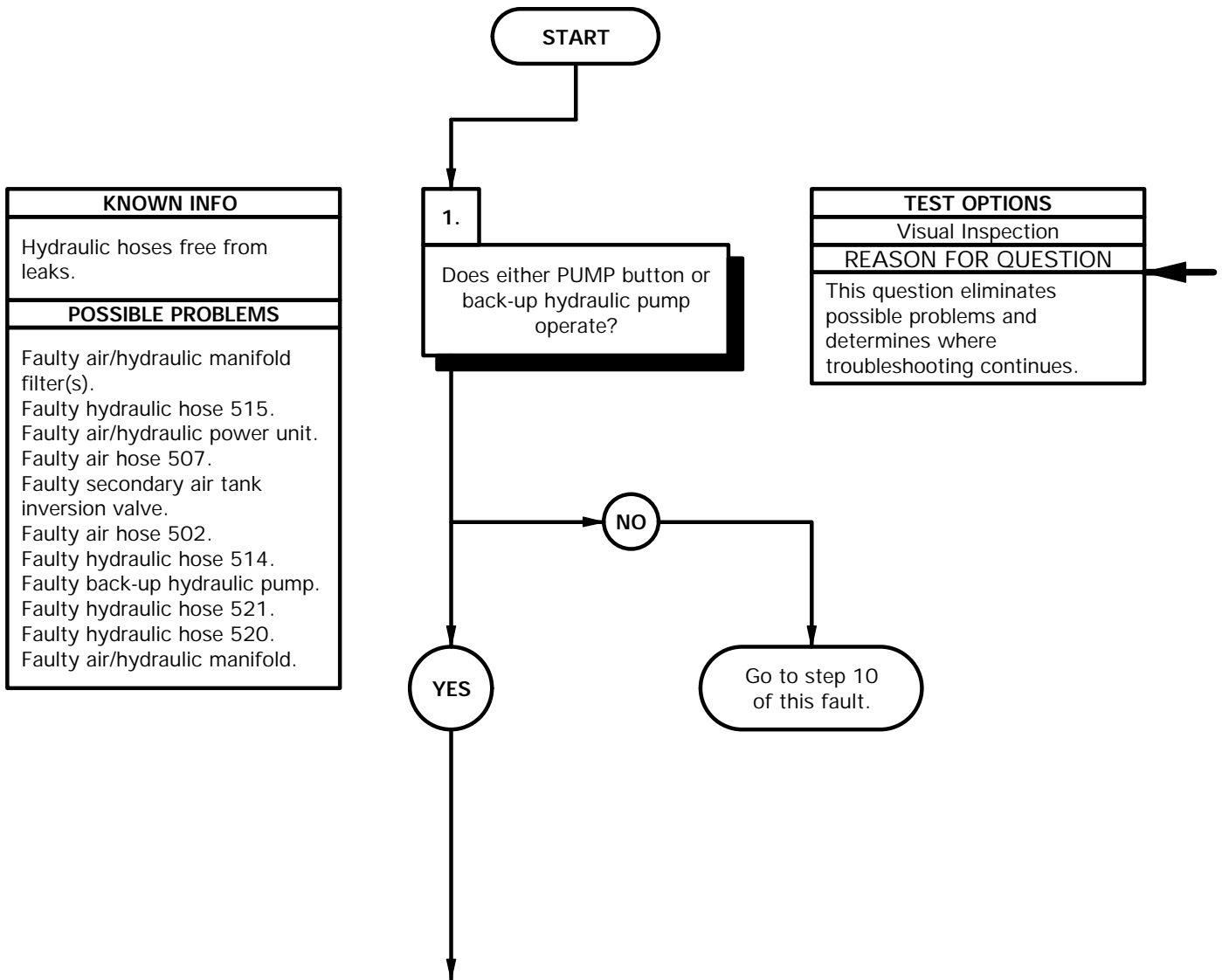
TM 9-4910-571-12&P



- 
- (1) Attempt to raise cab using PUMP button (TM 9-2320-366-10-1).
 - (2) Attempt to raise cab using back-up hydraulic pump (TM 9-2320-366-10-1).
 - (3) If cab does not raise in both steps (1) and (2), go to step 10 of this fault.
- 

u1. CAB TILT, SPARE TIRE RETAINER, AND SUSPENSION COMPRESSION DO NOT OPERATE (CONT)

KNOWN INFO
Hydraulic hoses free from leaks. Air/hydraulic manifold filters OK.
POSSIBLE PROBLEMS
Faulty hydraulic hose 515. Faulty air/hydraulic power unit. Faulty air hose 507. Faulty secondary air tank inversion valve. Faulty air hose 502. Faulty hydraulic hose 514. Faulty back-up hydraulic pump. Faulty hydraulic hose 521. Faulty hydraulic hose 520. Faulty air/hydraulic manifold.

TEST OPTIONS
Visual Inspection
REASON FOR QUESTION
This question eliminates possible problems and determines where troubleshooting continues.

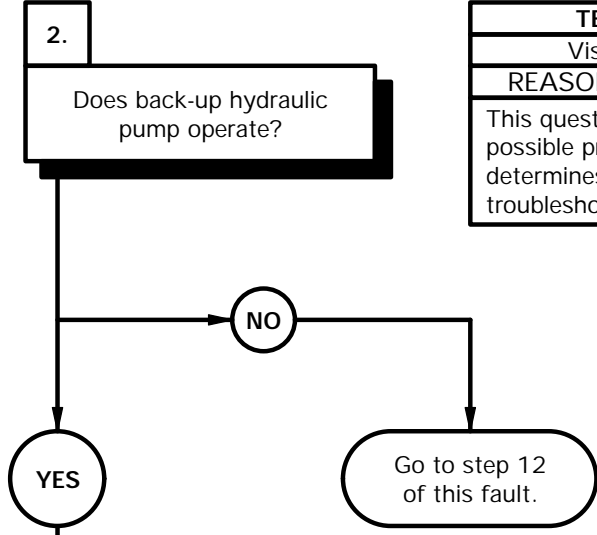

KNOWN INFO
Hydraulic hoses free from leaks. Air/hydraulic manifold filters OK. Back-up hydraulic pump OK. Hydraulic hose 521 OK. Hydraulic hose 520 OK.
POSSIBLE PROBLEMS
Faulty hydraulic hose 515. Faulty air/hydraulic power unit. Faulty air hose 507. Faulty secondary air tank inversion valve. Faulty air hose 502. Faulty hydraulic hose 514. Faulty air/hydraulic manifold.

TEST OPTIONS
Pressure Test or STE/ICE-R Test #51
REASON FOR QUESTION
This question eliminates possible problems and determines where troubleshooting continues.

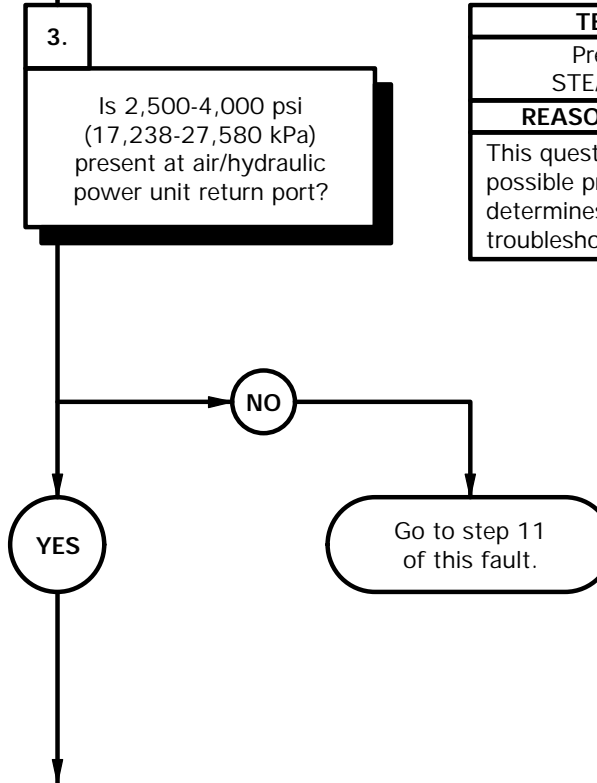

- (1) Attempt to raise cab using back-up hydraulic pump (TM 9-2320-366-10-1).
- (2) If cab does not raise, go to step 12 of this fault.
- (3) Lower cab (TM 9-2320-366-10-1).

PRESSURE TEST

- (1) Position drain pan under air/hydraulic power unit.
- (2) Disconnect hydraulic hose 514 from air/hydraulic power unit return port.
- (3) Connect STE/ICE-R between hydraulic hose 514 and return port.
- (4) Start engine (TM 9-2320-366-10-1).
- (5) Position SUSPENSION knob to LOWER (TM 9-2320-366-10-1).
- (6) Position FUNCTION SELECT knob to SUSPENSION (TM 9-2320-366-10-1).
- (7) Push and hold PUMP plunger button (TM 9-2320-366-10-1) and perform STE/ICE-R Test #51.
- (8) If 2,500-4,000 psi (17,238-27,580 kPa) is not present, go to step 11 of this fault.
- (9) Disconnect STE/ICE-R from hydraulic hose 514 and return port.
- (10) Connect hydraulic hose 514 to return port.

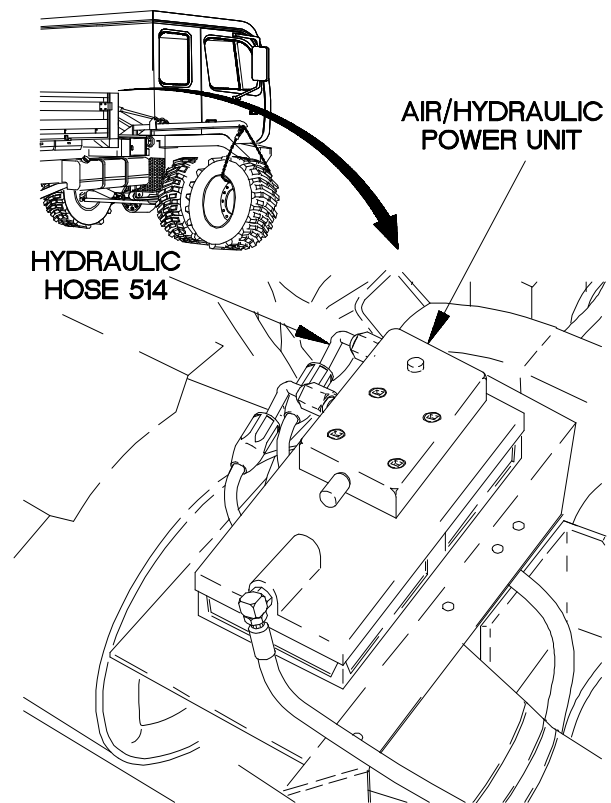

XBU0103B

u1. CAB TILT, SPARE TIRE RETAINER, AND SUSPENSION COMPRESSION DO NOT OPERATE (CONT)

KNOWN INFO
Hydraulic hoses free from leaks. Air/hydraulic manifold filters OK. Hydraulic hose 514 OK. Back-up hydraulic pump OK. Hydraulic hose 521 OK. Hydraulic hose 520 OK.
POSSIBLE PROBLEMS
Faulty hydraulic hose 515. Faulty air/hydraulic power unit. Faulty air hose 507. Faulty secondary air tank inversion valve. Faulty air hose 502. Faulty air/hydraulic manifold.

4.
Is 2,500-4,000 psi (17,238-27,580 kPa) present at port P1?

TEST OPTIONS
Pressure Test or STE/ICE-R Test #51
REASON FOR QUESTION
If 2,500-4,000 psi (17,238-27,580 kPa) is present, air/hydraulic manifold is faulty.

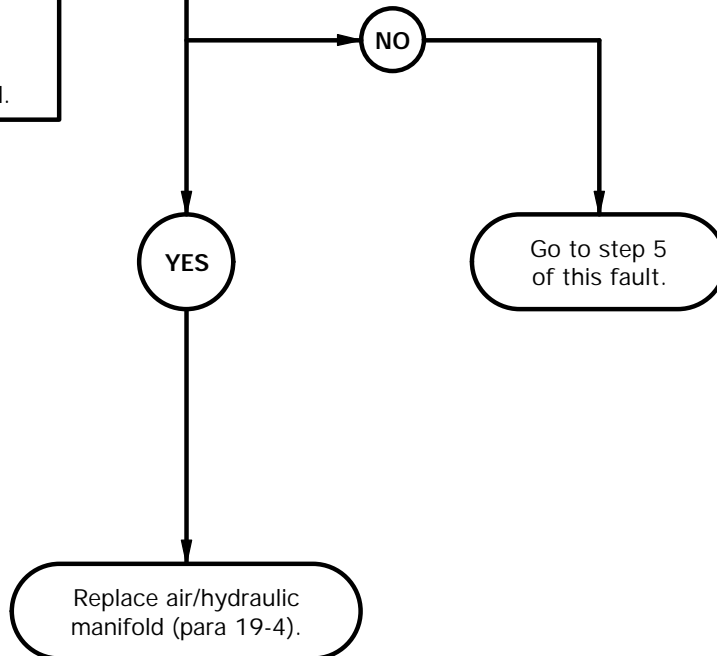

PRESSURE TEST

- (1) Position drain pan under air/hydraulic manifold.
- (2) Disconnect hydraulic hose 515 from port P1.
- (3) Connect STE/ICE-R between hydraulic hose 515 and port P1.
- (4) Start engine (TM 9-2320-366-10-1).
- (5) Position SUSPENSION knob to LOWER (TM 9-2320-366-10-1).
- (6) Position FUNCTION SELECT knob to SUSPENSION (TM 9-2320-366-10-1).
- (7) Push and hold PUMP plunger button (TM 9-2320-366-10-1) and perform STE/ICE-R Test #51.
- (8) If 2,500-4,000 psi (17,238-27,580 kPa) is not present, go to step 5 of this fault.
- (9) If 2,500-4,000 psi (17,238-27,580 kPa) is present, replace air/hydraulic manifold (para 19-4).
- (10) Disconnect STE/ICE-R from hydraulic hose 515 and port P1.
- (11) Connect hydraulic hose 515 to port P1.

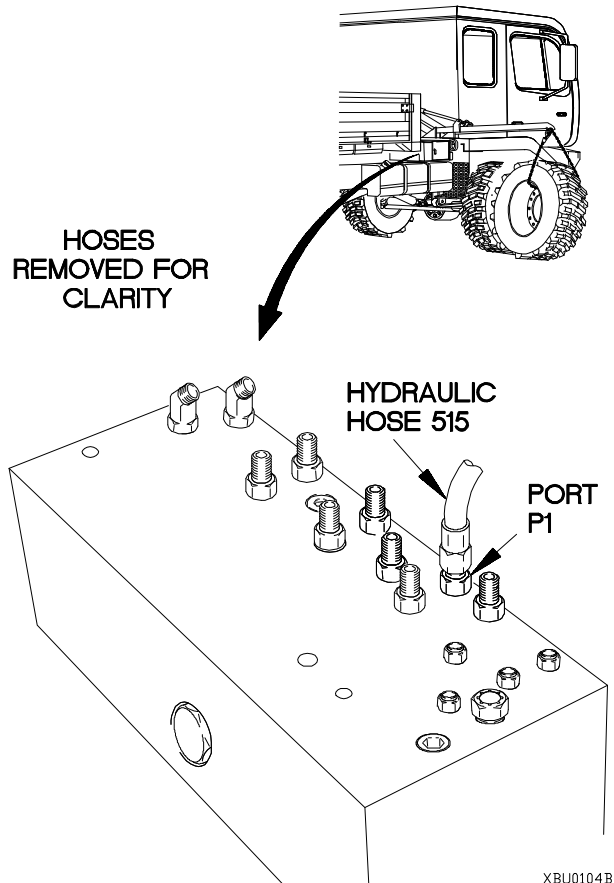

u1. CAB TILT, SPARE TIRE RETAINER, AND SUSPENSION COMPRESSION DO NOT OPERATE (CONT)

KNOWN INFO
Hydraulic hoses free from leaks. Air/hydraulic manifold filters OK. Hydraulic hose 514 OK. Back-up hydraulic pump OK. Hydraulic hose 521 OK. Hydraulic hose 520 OK.
POSSIBLE PROBLEMS
Faulty hydraulic hose 515. Faulty air/hydraulic power unit. Faulty air hose 507. Faulty secondary air tank inversion valve. Faulty air hose 502. Faulty air/hydraulic manifold.

5.
Is 2,500-4,000 psi (17,238-27,580 kPa) present at air/hydraulic power unit output port?

TEST OPTIONS
Pressure Test or STE/ICE-R Test #51
REASON FOR QUESTION
If 2,500-4,000 psi (17,238-27,580 kPa) is present, hydraulic hose 515 is faulty.

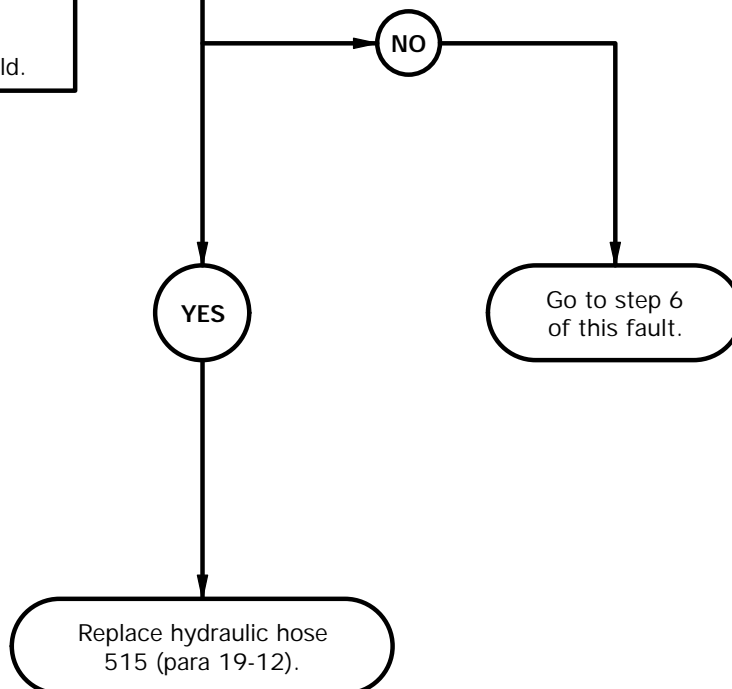

PRESSURE TEST

- (1) Position drain pan under air/hydraulic power unit.
- (2) Disconnect hydraulic hose 515 from output port.
- (3) Connect STE/ICE-R between hydraulic hose 515 and output port.
- (4) Start engine (TM 9-2320-366-10-1).
- (5) Position SUSPENSION knob to LOWER (TM 9-2320-366-10-1).
- (6) Position FUNCTION SELECT knob to SUSPENSION (TM 9-2320-366-10-1).
- (7) Push and hold PUMP plunger button (TM 9-2320-366-10-1) and perform STE/ICE-R Test #51.
- (8) If 2,500-4,000 psi (17,238-27,580 kPa) is not present, go to step 6 of this fault.
- (9) If 2,500-4,000 psi (17,238-27,580 kPa) is present, replace hydraulic hose 515 (para 19-12).
- (10) Disconnect STE/ICE-R from hydraulic hose 515 and output port.
- (11) Connect hydraulic hose 515 to output port.

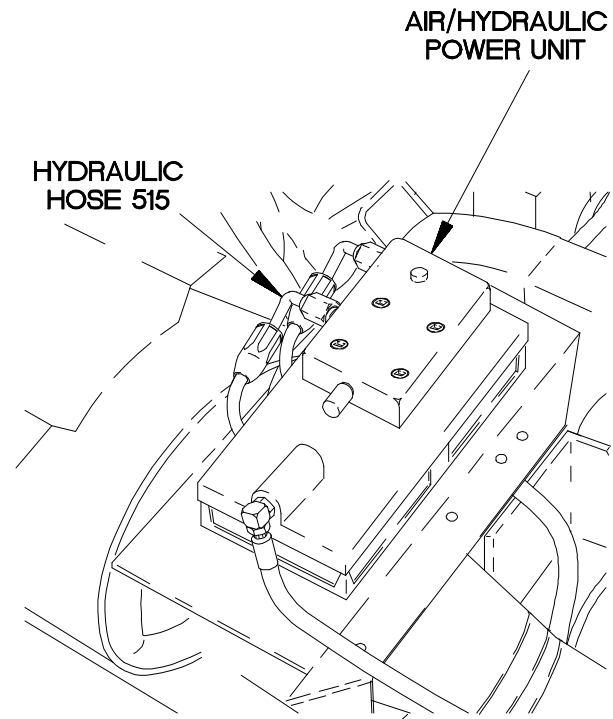

XBU0105B

u1. CAB TILT, SPARE TIRE RETAINER, AND SUSPENSION COMPRESSION DO NOT OPERATE (CONT)

KNOWN INFO
Hydraulic hoses free from leaks. Air/hydraulic manifold filters OK. Hydraulic hose 515 OK. Hydraulic hose 514 OK. Back-up hydraulic pump OK. Hydraulic hose 521 OK. Hydraulic hose 520 OK.
POSSIBLE PROBLEMS
Faulty air/hydraulic power unit. Faulty air hose 507. Faulty secondary air tank inversion valve. Faulty air hose 502. Faulty air/hydraulic manifold.

6.
Is air present at air/hydraulic power unit supply port?

TEST OPTIONS
Visual Inspection
REASON FOR QUESTION
If air is present, air/hydraulic power unit is faulty.

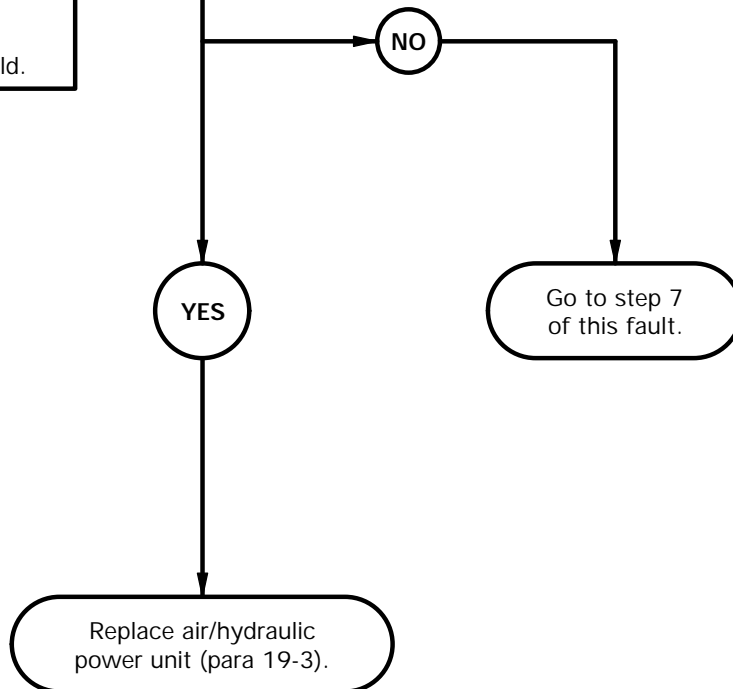

- (1) Drain air tanks (TM 9-2320-366-10-1).
- (2) Loosen air hose 507 at air/hydraulic power unit.
- (3) Start engine and charge air tanks (TM 9-2320-366-10-1).
- (4) Check for presence of air at air hose 507.
- (5) If air is not present, go to step 7 of this fault.
- (6) If air is present, replace air/hydraulic power unit (para 19-3).
- (7) Drain air tanks (TM 9-2320-366-10-1).
- (8) Tighten air hose 507 at air/hydraulic power unit.

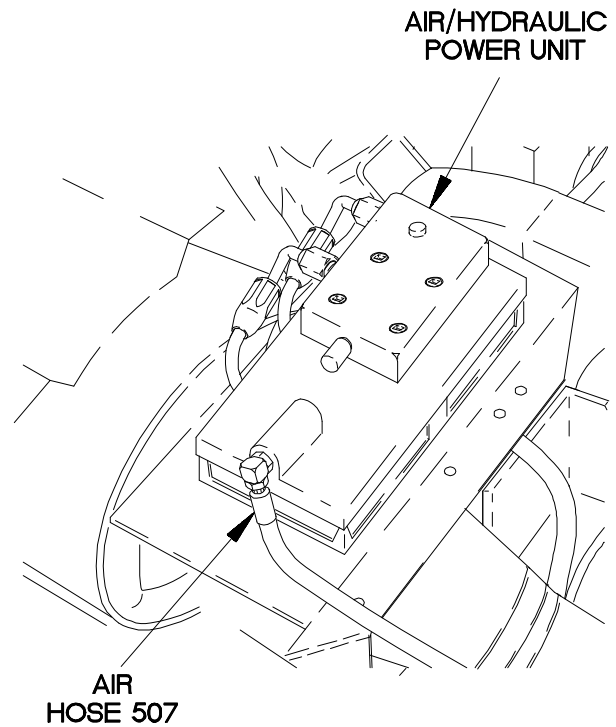

XBU0106B

u1. CAB TILT, SPARE TIRE RETAINER, AND SUSPENSION COMPRESSION DO NOT OPERATE (CONT)

KNOWN INFO
Hydraulic hoses free from leaks. Air/hydraulic manifold filters OK. Hydraulic hose 515 OK. Air/hydraulic power unit OK. Hydraulic hose 514 OK. Back-up hydraulic pump OK. Hydraulic hose 521 OK. Hydraulic hose 520 OK.
POSSIBLE PROBLEMS
Faulty air hose 507. Faulty secondary air tank inversion valve. Faulty air hose 502. Faulty air/hydraulic manifold.

7.
Is air present at PUMP CYL port?

TEST OPTIONS
Visual Inspection
REASON FOR QUESTION
If air is present, air hose 507 is faulty.

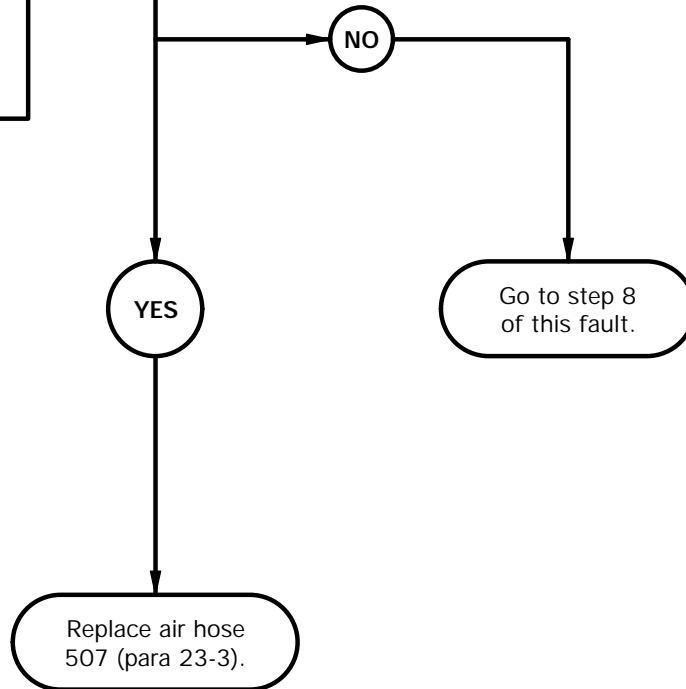

- (1) Drain air tanks (TM 9-2320-366-10-1).
- (2) Loosen air hose 507 at PUMP CYL port.
- (3) Start engine and charge air tanks (TM 9-2320-366-10-1).
- (4) Check for presence of air at PUMP CYL port.
- (5) If air is not present, go to step 8 of this fault.
- (6) If air is present, replace air hose 507 (para 23-3).
- (7) Drain air tanks (TM 9-2320-366-10-1).
- (8) Tighten air hose 507 at PUMP CYL port.

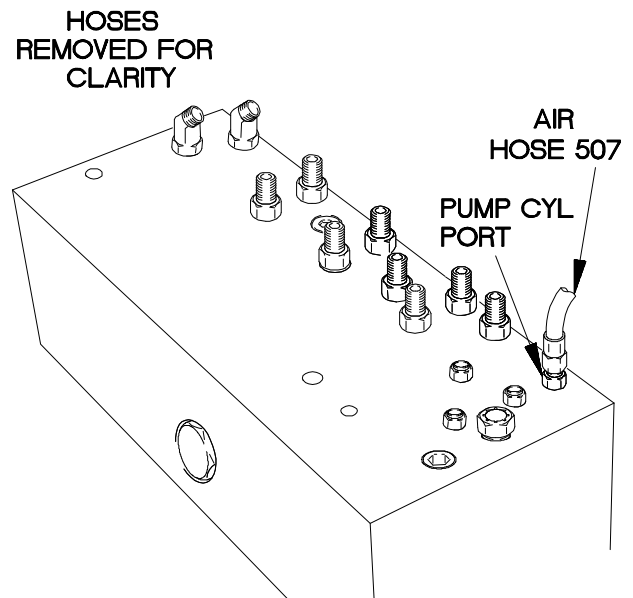

XBU0107B

u1. CAB TILT, SPARE TIRE RETAINER, AND SUSPENSION COMPRESSION DO NOT OPERATE (CONT)

KNOWN INFO
Hydraulic hoses free from leaks. Air/hydraulic manifold filters OK. Hydraulic hose 515 OK. Air/hydraulic power unit OK. Air hose 507. Hydraulic hose 514 OK. Back-up hydraulic pump OK. Hydraulic hose 521 OK. Hydraulic hose 520 OK.
POSSIBLE PROBLEMS
Faulty air/hydraulic manifold. Faulty secondary air tank inversion valve. Faulty air hose 502.

8.
Is air present at AIR IN P port?

TEST OPTIONS
Visual Inspection
REASON FOR QUESTION
If air is present, air/hydraulic manifold is faulty.

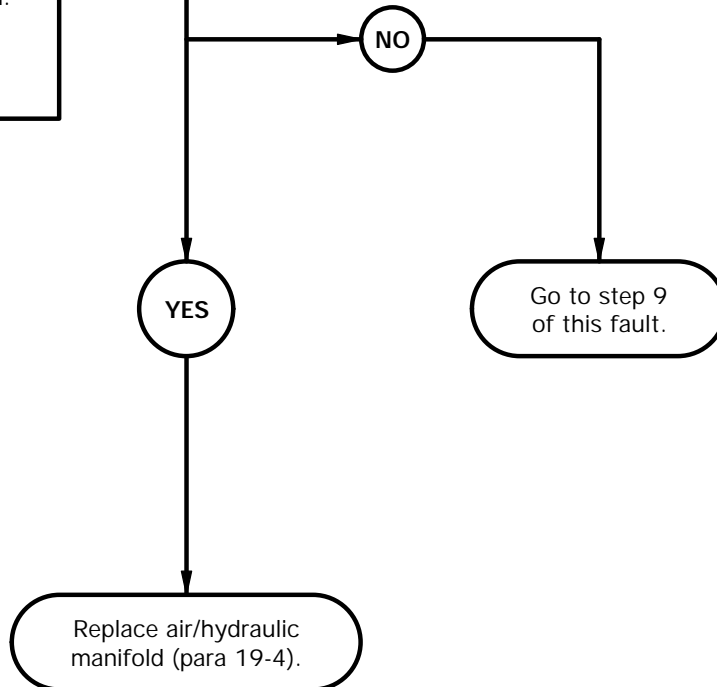

- (1) Drain air tanks (TM 9-2320-366-10-1).
- (2) Loosen air hose 502 at AIR IN P port.
- (3) Start engine and charge air tanks (TM 9-2320-366-10-1).
- (4) Check for presence of air at air hose 502.
- (5) If air is not present, go to step 9 of this fault.
- (6) If air is present, replace air/hydraulic manifold (para 19-4).
- (7) Drain air tanks (TM 9-2320-366-10-1).
- (8) Tighten air hose 502 at AIR IN P port.

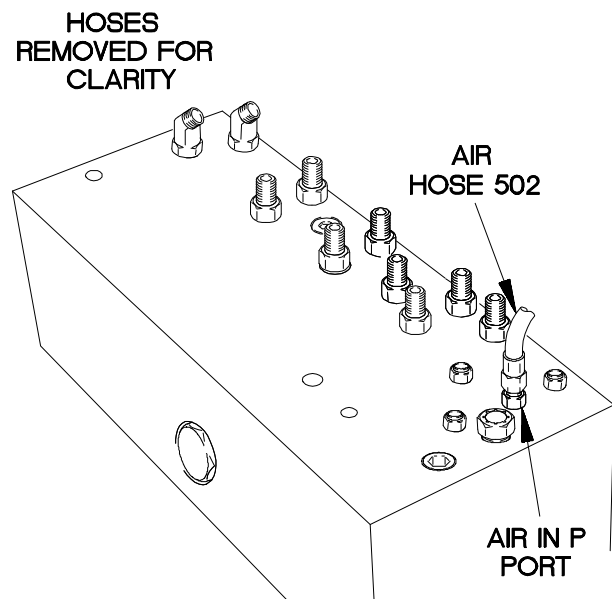

XBU0108B

u1. CAB TILT, SPARE TIRE RETAINER, AND SUSPENSION COMPRESSION DO NOT OPERATE (CONT)

KNOWN INFO
Hydraulic hoses free from leaks. Air/hydraulic manifold filters OK. Hydraulic hose 515 OK. Air/hydraulic power unit OK. Air hose 507. Hydraulic hose 514 OK. Back-up hydraulic pump OK. Hydraulic hose 521 OK. Hydraulic hose 520 OK. Air/hydraulic manifold OK.
POSSIBLE PROBLEMS
Faulty secondary air tank inversion valve. Faulty air hose 502.

9.
Is air present at secondary air tank inversion valve delivery port?

TEST OPTIONS
Visual Inspection
REASON FOR QUESTION
If air is not present, secondary air tank inversion valve is faulty. If air is present, air hose 502 is faulty.

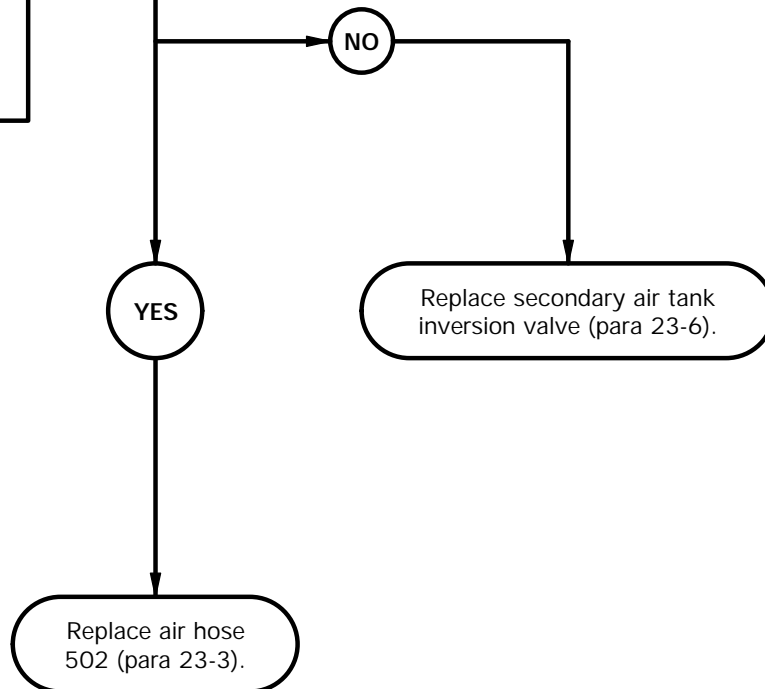

- (1) Drain air tanks (TM 9-2320-366-10-1).
- (2) Loosen air hose 502 at secondary air tank inversion valve delivery port.
- (3) Start engine and charge air tanks (TM 9-2320-366-10-1).
- (4) Check for presence of air at secondary air tank inversion valve delivery port.
- (5) If air is not present, replace secondary air tank inversion valve (para 23-6).
- (6) If air is present, replace air hose 502 (para 23-3).
- (7) Drain air tanks (TM 9-2320-366-10-1).
- (8) Tighten air hose 502 at secondary air tank inversion valve delivery port.

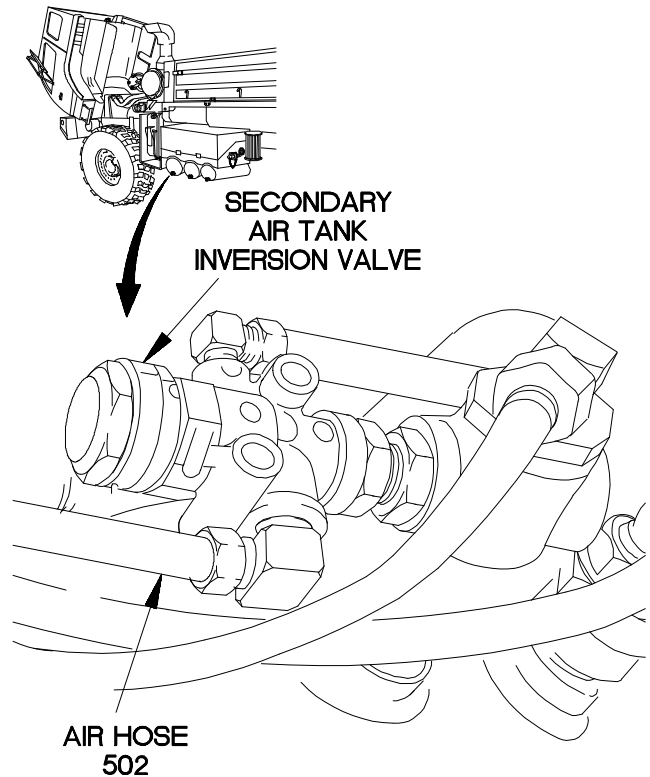

Xbu0109b

u1. CAB TILT, SPARE TIRE RETAINER, AND SUSPENSION COMPRESSION DO NOT OPERATE (CONT)

KNOWN INFO
Hydraulic hoses free from leaks. Hydraulic hose 515 OK. Air/hydraulic power unit OK. Air hose 507 OK. Secondary air tank inversion valve OK. Air hose 502 OK. Hydraulic hose 514 OK. Back-up hydraulic pump OK. Hydraulic hose 521 OK. Hydraulic hose 520 OK.
POSSIBLE PROBLEMS
Debris in air/hydraulic manifold filter(s). Faulty air/hydraulic manifold.

WARNING
Read WARNING on following page.

10.
Are air/hydraulic manifold filters free from debris?

TEST OPTIONS
Visual Inspection
REASON FOR QUESTION
If air/hydraulic manifold filter(s) is clogged, filter(s) is faulty.

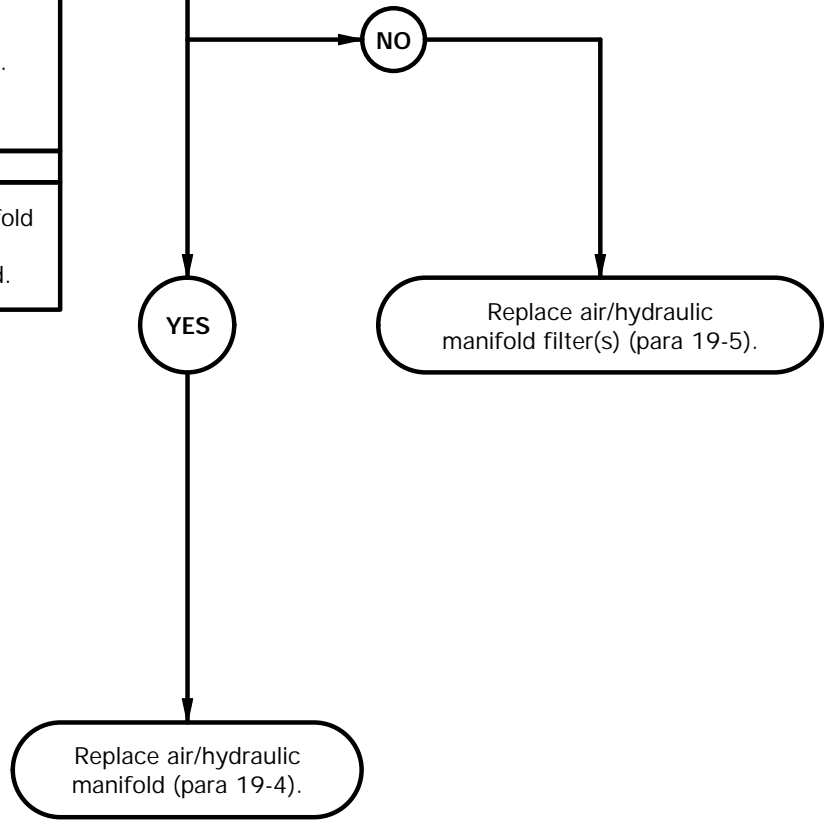

WARNING

Drop hydraulic pressure to zero before disconnecting any hydraulic hoses. Failure to comply may result in injury to personnel.

Hydraulic fluid (MIL-H-5606) is TOXIC. Wear protective goggles and gloves; use only in well ventilated area; avoid contact with skin, eyes, and clothes. Skin and clothing that come into contact with hydraulic fluid should be washed immediately. Saturated clothing should be removed immediately. Failure to comply may result in injury to personnel.

Compressed air used for cleaning purposes will not exceed 30 psi (270 kPa). Use only with effective chip guarding and personal protective equipment (goggles, shields, gloves, etc.). Failure to comply may result in injury to personnel.

- (1) Remove two plugs from air/hydraulic manifold. Discard plugs.
- (2) Remove two retainers, filters, and springs from air/hydraulic manifold. Discard retainers and springs.
- (3) Inspect filters for debris or signs of damage.
- (4) Discard filters.
- (5) If filters are free from debris and damage, repair or replace air/hydraulic manifold (para 19-4).
- (6) Position two springs and filters in hydraulic manifold with two retainers.
- (7) Install two preformed packings on plugs.
- (8) Install two plugs in air/hydraulic manifold.

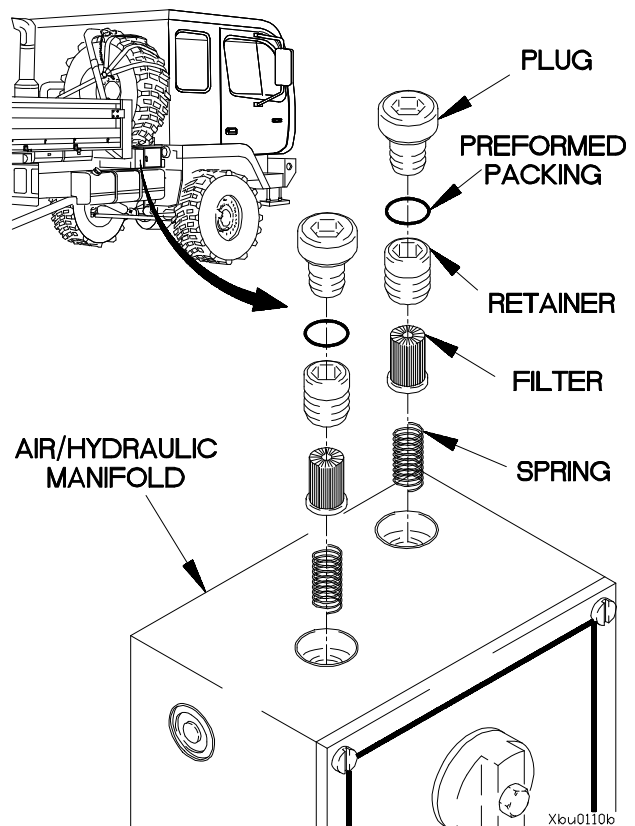

u1. CAB TILT, SPARE TIRE RETAINER, AND SUSPENSION COMPRESSION DO NOT OPERATE (CONT)

KNOWN INFO
Hydraulic hoses free from leaks. Air/hydraulic manifold filters OK. Hydraulic hose 515. Air/hydraulic power unit OK. Air hose 507 OK. Secondary air tank inversion valve OK. Air hose 502 OK. Back-up hydraulic pump OK. Hydraulic hose 521 OK. Hydraulic hose 520 OK.
POSSIBLE PROBLEMS
Faulty hydraulic hose 514. Faulty air/hydraulic manifold.

11.
Is 2,500-4,000 psi (17,238-27,580 kPa) present at port T1?

TEST OPTIONS
Pressure Test or STE/ICE-R Test #51
REASON FOR QUESTION
If 2,500-4,000 psi (17,238-27,580 kPa) is not present, air/hydraulic manifold is faulty. If 2,500-4,000 psi (17,238-27,580 kPa) is present, hydraulic hose 514 is faulty.

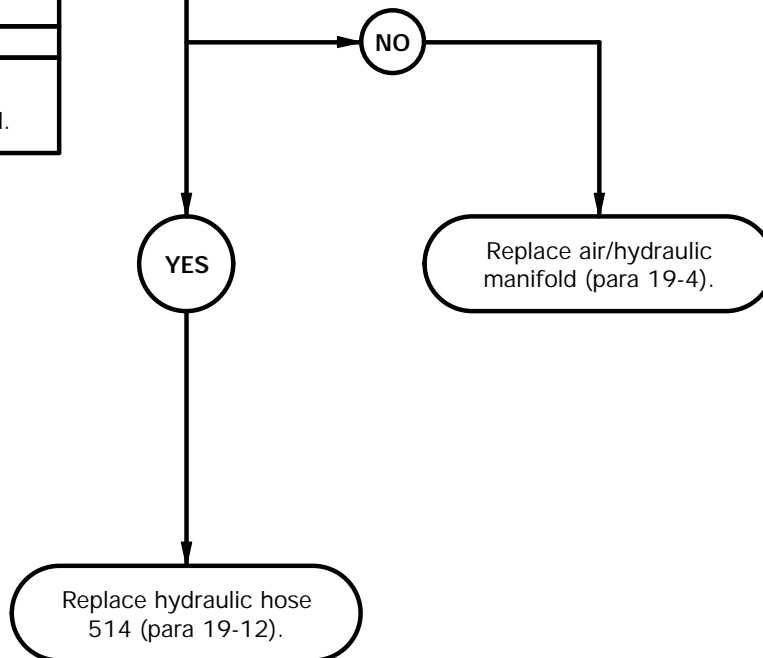

PRESSURE TEST

- (1) Position drain pan under air/hydraulic manifold.
- (2) Disconnect hydraulic hose 514 from port T1.
- (3) Connect STE/ICE-R between hydraulic hose 514 and port T1.
- (4) Start engine (TM 9-2320-366-10-1).
- (5) Position SUSPENSION knob to LOWER (TM 9-2320-366-10-1).
- (6) Position FUNCTION SELECT knob to SUSPENSION (TM 9-2320-366-10-1).
- (7) Push and hold PUMP plunger button (TM 9-2320-366-10-1) and perform STE/ICE-R Test #51.
- (8) If 2,500-4,000 psi (17,238-27,580 kPa) is not present, replace air/hydraulic manifold (para 19-4).
- (9) If 2,500-4,000 psi (17,238-27,580 kPa) is present, replace hydraulic hose 514 (para 19-12).
- (10) Disconnect STE/ICE-R from hydraulic hose 514 and port T1.
- (11) Connect hydraulic hose 514 to port T1.

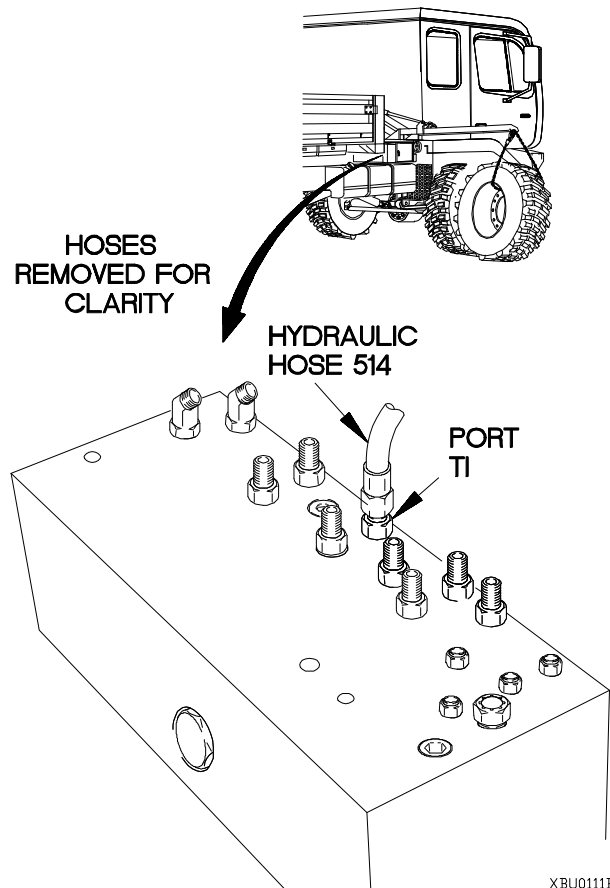

XBU0111B

u1. CAB TILT, SPARE TIRE RETAINER, AND SUSPENSION COMPRESSION DO NOT OPERATE (CONT)

KNOWN INFO
Hydraulic hoses free from leaks. Air/hydraulic manifold filters OK. Hydraulic hose 515 OK. Air/hydraulic power unit OK. Air hose 507 OK. Secondary air tank inversion valve OK. Air hose 502 OK. Air hose 514 OK.
POSSIBLE PROBLEMS
Faulty back-up hydraulic pump. Faulty hydraulic hose 521. Faulty hydraulic hose 520. Faulty air/hydraulic manifold.

12.
Is 2,500-4,000 psi (17,238-27,580 kPa) present at back-up hydraulic pump return port?

TEST OPTIONS
Pressure Test or STE/ICE-R Test #51
REASON FOR QUESTION
This question eliminates possible problems and determines where troubleshooting continues.

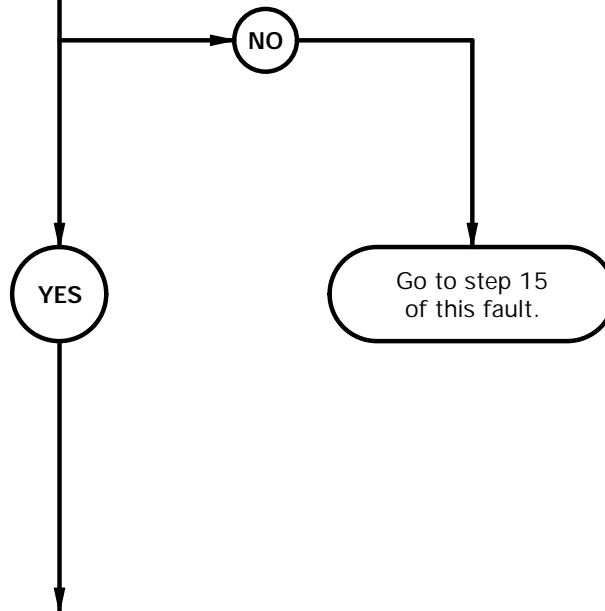

PRESSURE TEST

- (1) Position drain pan under back-up hydraulic pump.
- (2) Disconnect hydraulic hose 520 from back-up hydraulic pump return port.
- (3) Connect STE/ICE-R between hydraulic hose 520 and return port.
- (4) Start engine (TM 9-2320-366-10-1).
- (5) Position SUSPENSION knob to LOWER (TM 9-2320-366-10-1).
- (6) Position FUNCTION SELECT knob to SUSPENSION (TM 9-2320-366-10-1).
- (7) Push and hold PUMP plunger button (TM 9-2320-366-10-1) and perform STE/ICE-R Test #51.
- (8) If 2,500-4,000 psi (17,238-27,580 kPa) is not present, go to step 15 of this fault.
- (9) Disconnect STE/ICE-R from hydraulic hose 520 and return port.
- (10) Connect hydraulic hose 520 to return port.

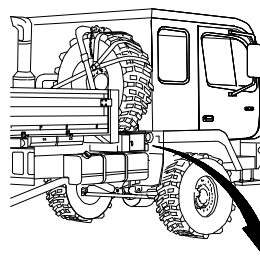

**BACK-UP HYDRAULIC
PUMP COVER
REMOVED FOR CLARITY**

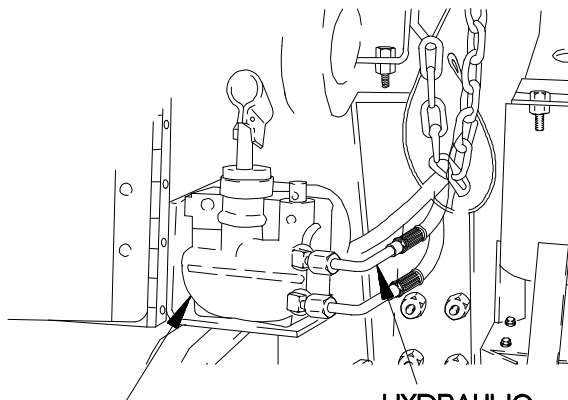

**BACK-UP
HYDRAULIC PUMP**

**HYDRAULIC
HOSE 520**

XBU0112B

u1. CAB TILT, SPARE TIRE RETAINER, AND SUSPENSION COMPRESSION DO NOT OPERATE (CONT)

KNOWN INFO
Hydraulic hoses free from leaks. Air/hydraulic manifold filters OK. Hydraulic hose 515 OK. Air/hydraulic power unit OK. Air hose 507 OK. Secondary air tank inversion valve OK. Air hose 502 OK. Air hose 514 OK. Air hose 520 OK.
POSSIBLE PROBLEMS
Faulty back-up hydraulic pump. Faulty hydraulic hose 521. Faulty air/hydraulic manifold.

13.
Is 2,500-4,000 psi (17,238-27,580 kPa) present at port P2?

TEST OPTIONS
Pressure Test or STE/ICE-R Test #51
REASON FOR QUESTION
If 2,500-4,000 psi (17,238-27,580 kPa) is present, air/hydraulic manifold is faulty.

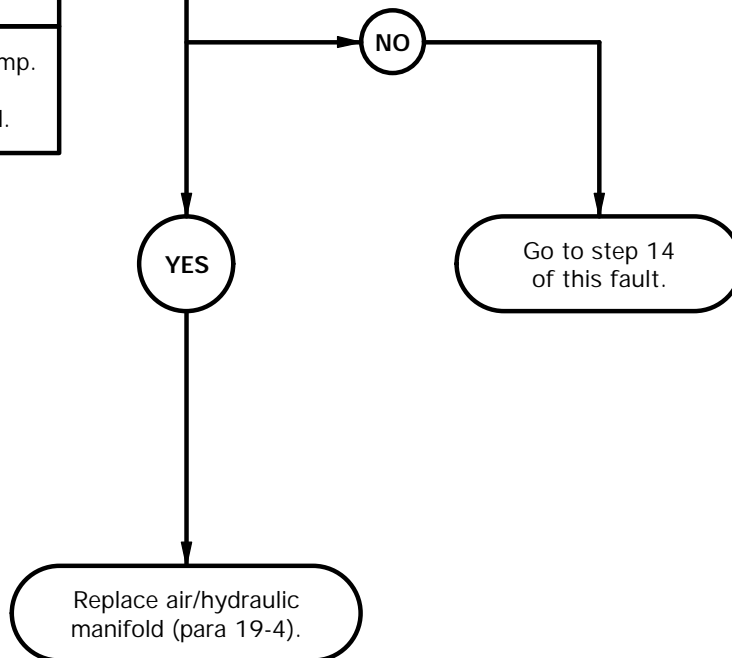

PRESSURE TEST

- (1) Position drain pan under air/hydraulic manifold.
- (2) Disconnect hydraulic hose 521 from port P2.
- (3) Connect STE/ICE-R between hydraulic hose 521 and port P2.
- (4) Position SUSPENSION knob to LOWER (TM 9-2320-366-10-1).
- (5) Position FUNCTION SELECT knob to SUSPENSION (TM 9-2320-366-10-1).
- (6) Operate back-up hydraulic pump (TM 9-2320-366-10-1) and perform STE/ICE-R Test #51.
- (7) If 2,500-4,000 psi (17,238-27,580 kPa) is not present, go to step 14 of this fault.
- (8) If 2,500-4,000 psi (17,238-27,580 kPa) is present, replace air/hydraulic manifold (para 19-4).
- (9) Disconnect STE/ICE-R from hydraulic hose 521 and port P2.
- (10) Connect hydraulic hose 521 to port P2.

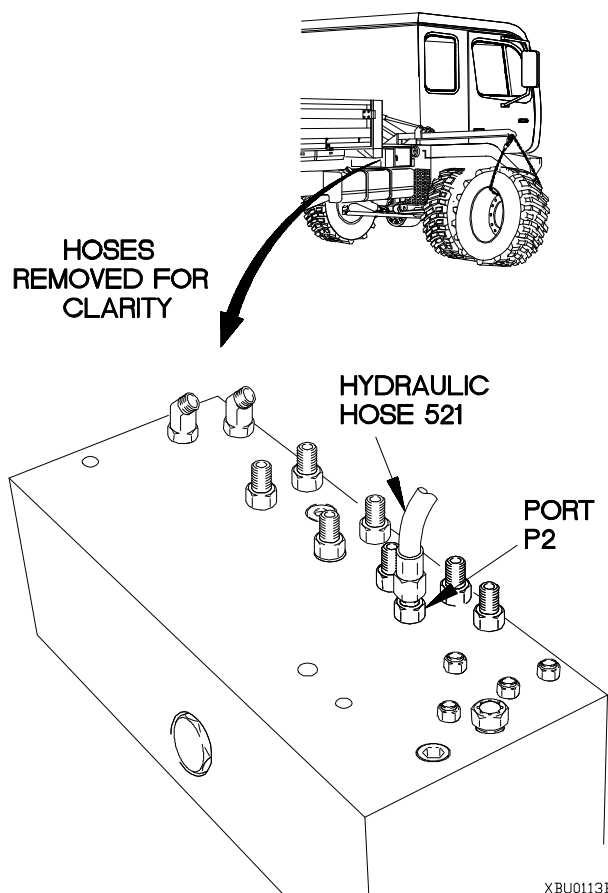

u1. CAB TILT, SPARE TIRE RETAINER, AND SUSPENSION COMPRESSION DO NOT OPERATE (CONT)

KNOWN INFO
Hydraulic hoses free from leaks. Air/hydraulic manifold filters OK. Hydraulic hose 515 OK. Air/hydraulic power unit OK. Air hose 507 OK. Secondary air tank inversion valve OK. Air hose 502 OK. Air hose 514 OK. Hydraulic hose 520 OK. Air/hydraulic manifold OK.
POSSIBLE PROBLEMS
Faulty back-up hydraulic pump. Faulty hydraulic hose 521.

14.
Is 2,500-4,000 psi (17,238-27,580 kPa) present at back-up hydraulic pump output port?

TEST OPTIONS
Pressure Test or STE/ICE-R Test #51
REASON FOR QUESTION
If 2,500-4,000 psi (17,238-27,580 kPa) is not present, back-up hydraulic pump is faulty. If 2,500-4,000 psi (17,238-27,580 kPa) is present, hydraulic hose 521 is faulty.

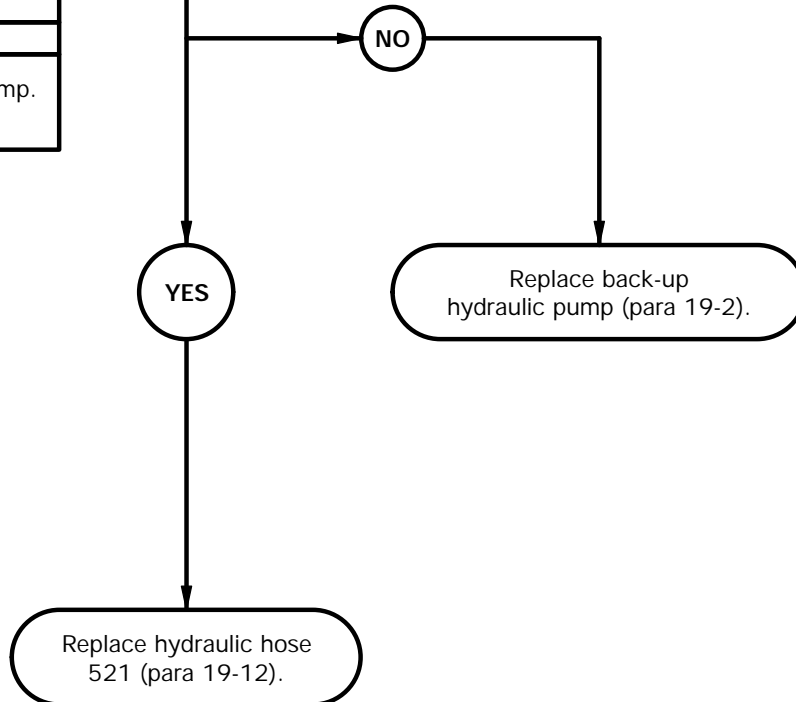

PRESSURE TEST

- (1) Position drain pan under back-up hydraulic pump.
- (2) Disconnect hydraulic hose 521 from back-up hydraulic pump output port.
- (3) Connect STE/ICE-R between hydraulic hose 521 and output port.
- (4) Position SUSPENSION knob to LOWER (TM 9-2320-366-10-1).
- (5) Position FUNCTION SELECT knob to SUSPENSION (TM 9-2320-366-10-1).
- (6) Operate back-up hydraulic pump (TM 9-2320-366-10-1) and perform STE/ICE-R Test #51.
- (7) If 2,500-4,000 psi (17,238-27,580 kPa) is not present, replace back-up hydraulic pump (para 19-2).
- (8) If 2,500-4,000 psi (17,238-27,580 kPa) is present, replace hydraulic hose 521 (para 19-12).
- (9) Disconnect STE/ICE-R from hydraulic hose 521 and output port.
- (10) Connect hydraulic hose 521 to output port.

**BACK-UP HYDRAULIC
PUMP COVER
REMOVED FOR CLARITY**

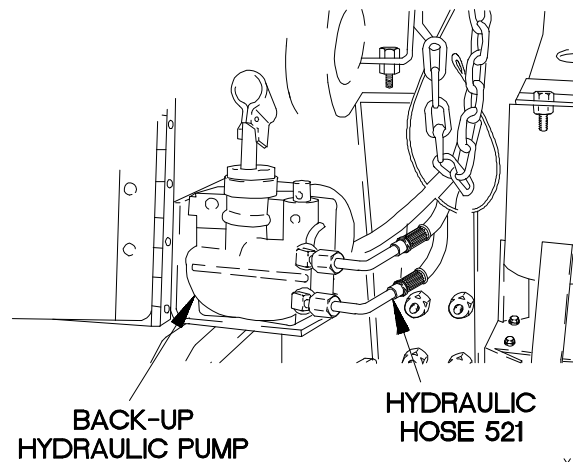

XBU0114B

u1. CAB TILT, SPARE TIRE RETAINER, AND SUSPENSION COMPRESSION DO NOT OPERATE (CONT)

KNOWN INFO
Hydraulic hoses free from leaks. Air/hydraulic manifold filters OK. Hydraulic hose 515. Air/hydraulic power unit OK. Air hose 507 OK. Secondary air tank inversion valve OK. Air hose 502 OK. Hydraulic hose 514 OK. Back-up hydraulic pump OK. Hydraulic hose 521 OK.
POSSIBLE PROBLEMS
Faulty hydraulic hose 520. Faulty air/hydraulic manifold.

15.
Is 2,500-4,000 psi (17,238-27,580 kPa) present at port T2?

TEST OPTIONS
Pressure Test or STE/ICE-R Test #51
REASON FOR QUESTION
If 2,500-4,000 psi (17,238-27,580 kPa) is not present, air/hydraulic manifold is faulty. If 2,500-4,000 psi (17,238-27,580 kPa) is present, hydraulic hose 520 is faulty.

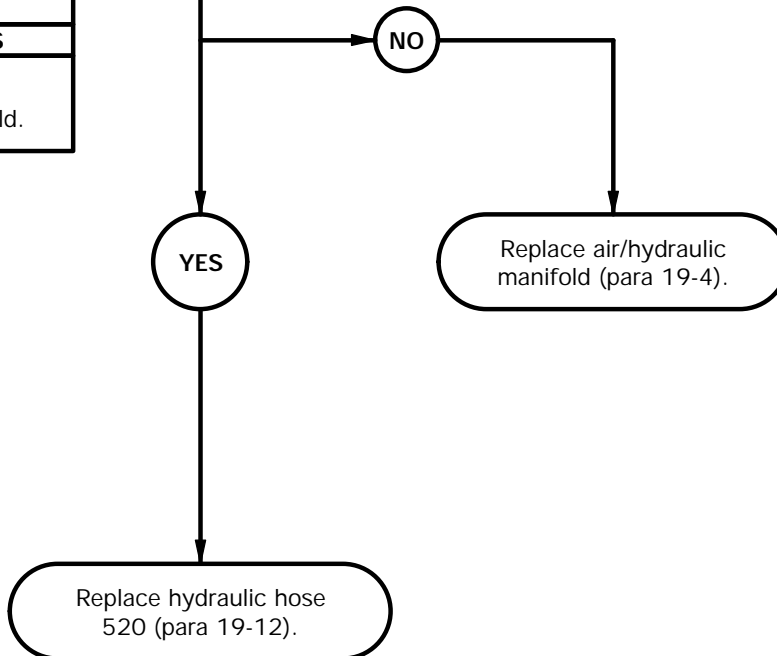

PRESSURE TEST

- (1) Position drain pan under air/hydraulic manifold.
- (2) Disconnect hydraulic hose 520 from port T2.
- (3) Connect STE/ICE-R between hydraulic hose 520 and port T2.
- (4) Start engine (TM 9-2320-366-10-1).
- (5) Position SUSPENSION knob to LOWER (TM 9-2320-366-10-1).
- (6) Position FUNCTION SELECT knob to SUSPENSION (TM 9-2320-366-10-1).
- (7) Push and hold PUMP plunger button (TM 9-2320-366-10-1) and perform STE/ICE-R Test #51.
- (8) If 2,500-4,000 psi (17,238-27,580 kPa) is not present, replace air/hydraulic manifold (para 19-4).
- (9) If 2,500-4,000 psi (17,238-27,580 kPa) is present, replace hydraulic hose 520 (para 19-12).
- (10) Disconnect STE/ICE-R from hydraulic hose 520 and port T2.
- (11) Connect hydraulic hose 520 to port T2.

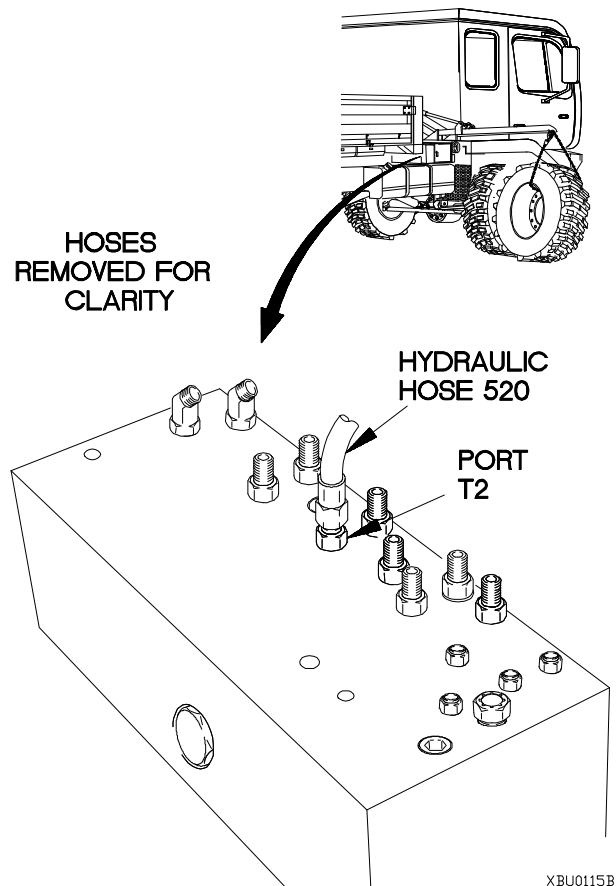

XBU0115B

u2. SUSPENSION DOES NOT COMPRESS AND/OR RETURN TO NORMAL

INITIAL SETUP

Equipment Condition

Engine shut down (TM 9-2320-366-10-1).

Personnel Required

(2)

Material/Parts

Rag, Wiping (Item 50, Appendix D)

Tools and Special Tools

Tool Kit, Genl Mech (Item 46, Appendix C)
 STE/ICE-R (Item 41, Appendix C)
 Pan, Drain (Item 24, Appendix C)
 Goggles, Industrial (Item 15, Appendix C)
 Transducer, 10,000 PSI (Item 1, Appendix J)
 Gloves, Rubber (Item 13, Appendix C)

References

TM 9-4910-571-12&P

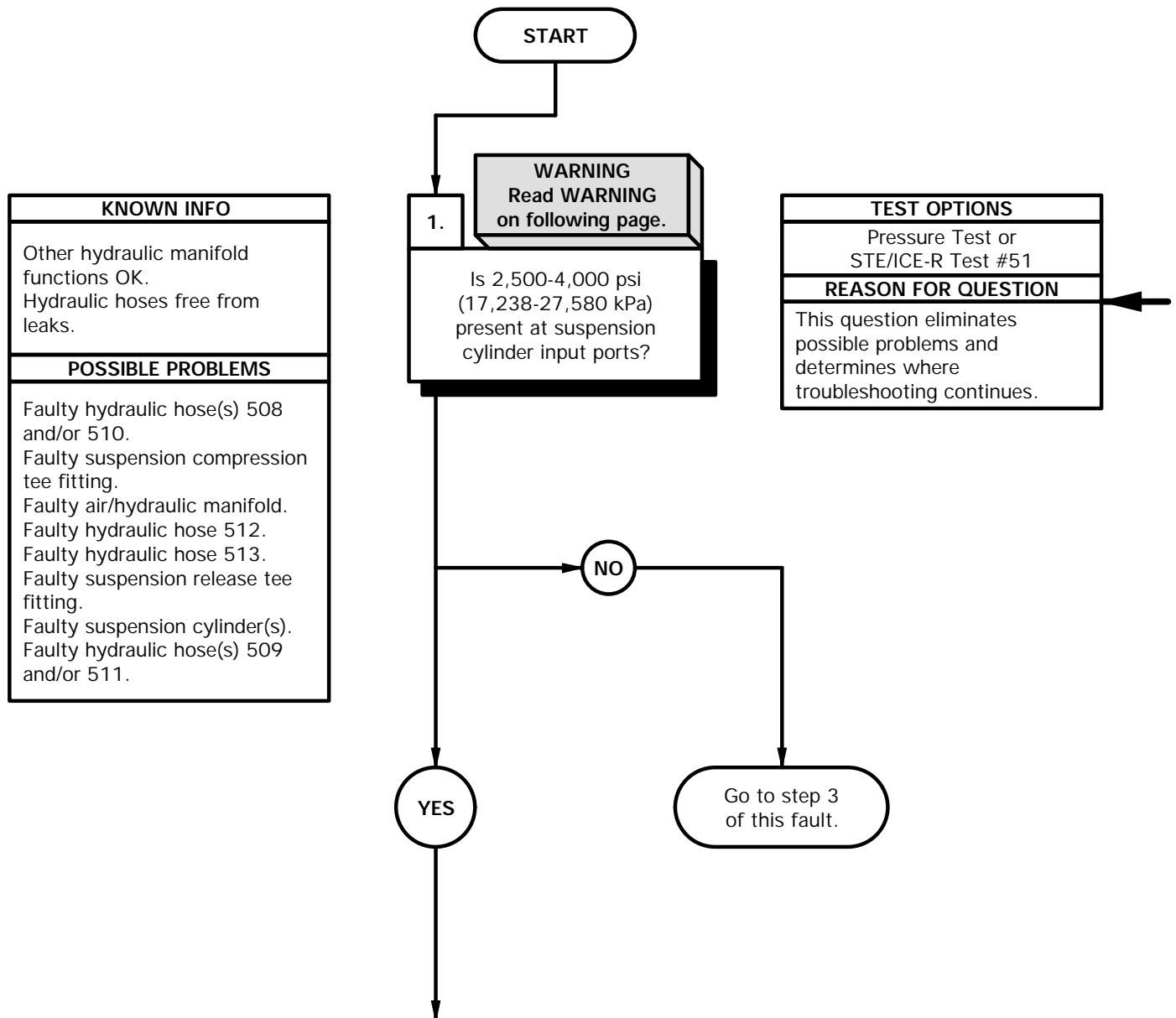

WARNING

Drop hydraulic pressure to zero before disconnecting any hydraulic hoses. Failure to comply may result in injury to personnel.

Hydraulic oil (MIL-H 5605) is TOXIC. Wear protective goggles and gloves. Use only in well ventilated area. Avoid contact with skin, eyes, and clothes. Skin and clothing that come into contact with hydraulic oil should be washed immediately. Failure to comply may result in injury to personnel.

NOTE

SYSTEM PARK control must be engaged (TM 9-2320-366-10-1) before operating SUSPENSION compression.

PRESSURE TEST

- (1) Position drain pan under RH suspension cylinder.
- (2) Disconnect hydraulic hose 508 from RH suspension cylinder input port.
- (3) Connect STE/ICE-R between hydraulic hose 508 and RH suspension cylinder input port.
- (4) Start engine (TM 9-2320-366-10-1).
- (5) Position FUNCTION SELECT knob to SUSPENSION (TM 9-2320-366-10-1).
- (6) Push and hold PUMP plunger button (TM 9-2320-366-10-1) and perform STE/ICE-R Test #51.
- (7) Shut down engine (TM 9-2320-366-10-1).
- (8) Disconnect STE/ICE-R from RH suspension cylinder input port and hydraulic hose 508.
- (9) Connect hydraulic hose 508 to RH suspension cylinder input port.
- (10) Repeat steps (1) through (9) on LH suspension cylinder and hydraulic hose 510.
- (11) If 2,500-4,000 psi (17,238-27,580 kPa) is not present at either suspension cylinder, go to step 3 of this fault.

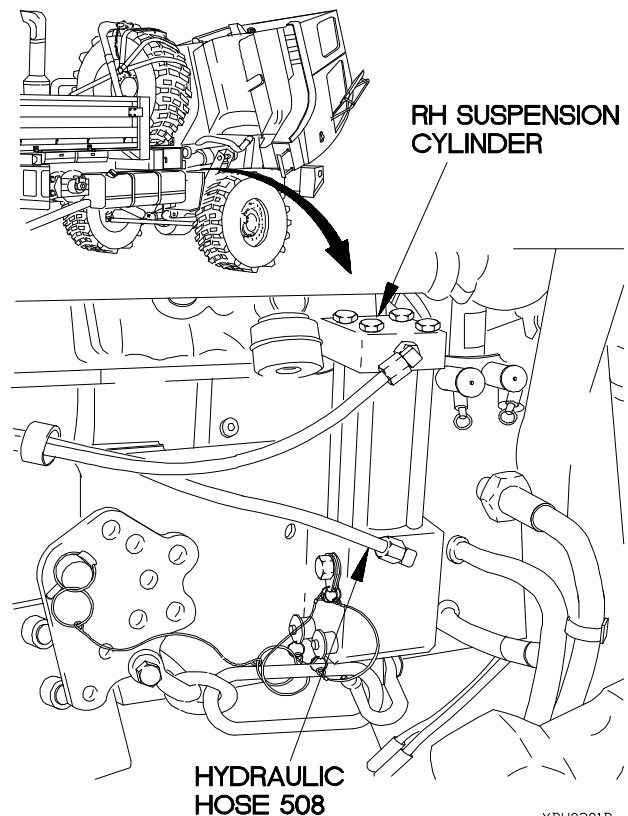

XBU0201B

u2. SUSPENSION DOES NOT COMPRESS AND/OR RETURN TO NORMAL (CONT)

KNOWN INFO
Other hydraulic manifold functions OK. Hydraulic hoses free from leaks. Hydraulic hoses 508 and 510 OK. Suspension compression tee fitting OK. Hydraulic hose 512 OK.
POSSIBLE PROBLEMS
Faulty air/hydraulic manifold. Faulty hydraulic hose 513. Faulty suspension release tee fitting. Faulty suspension cylinder(s). Faulty hydraulic hose(s) 509 and/or 511.

2.
Is 2,500-4,000 psi (17,238-27,580 kPa) present at PILOT input port?

TEST OPTIONS
Pressure Test or STE/ICE-R Test #51
REASON FOR QUESTION
If 2,500-4,000 psi (17,238-27,580 kPa) is present, air/hydraulic manifold is faulty.

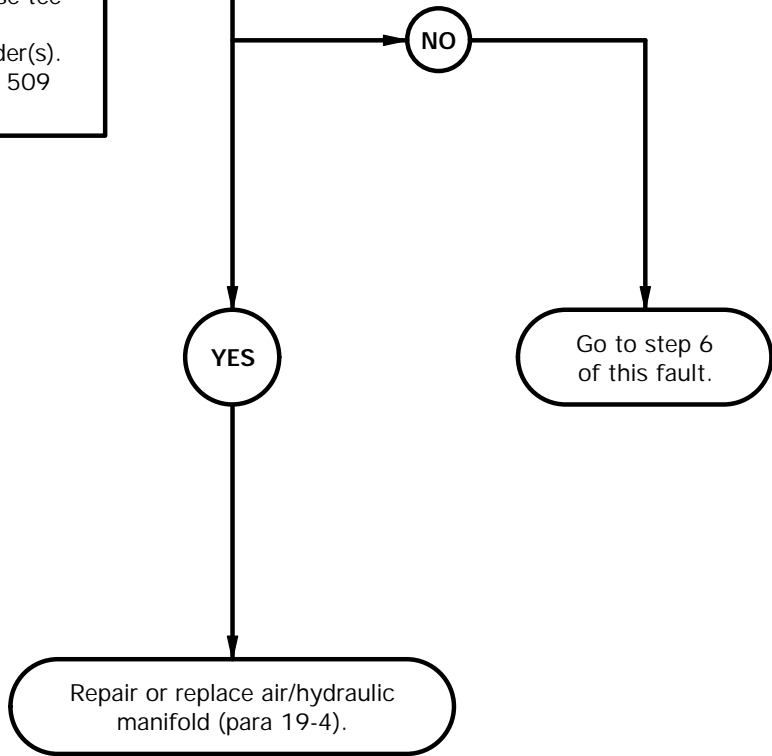

PRESSURE TEST

- (1) Position drain pan under air/hydraulic manifold
- (2) Disconnect hydraulic hose 513 from PILOT port.
- (3) Connect STE/ICE-R between hydraulic hose 513 and PILOT port.
- (4) Start engine (TM 9-2320-366-10-1).
- (5) Position SUSPENSION knob to LOWER (TM 9-2320-366-10-1).
- (6) Position FUNCTION SELECT knob to SUSPENSION (TM 9-2320-366-10-1).
- (7) Push and hold PUMP plunger button (TM 9-2320-366-10-1) and perform STE/ICE-R Test #51.
- (8) If 2,500-4,000 psi (17,238-27,580 kPa) is not present, go to step 6 of this fault.
- (9) If 2,500-4,000 psi (17,238-27,580 kPa) is present, repair or replace air/hydraulic manifold (para 19-4).
- (10) Disconnect STE/ICE-R from hydraulic hose 513 and PILOT port.
- (11) Connect hydraulic hose 513 to PILOT port.

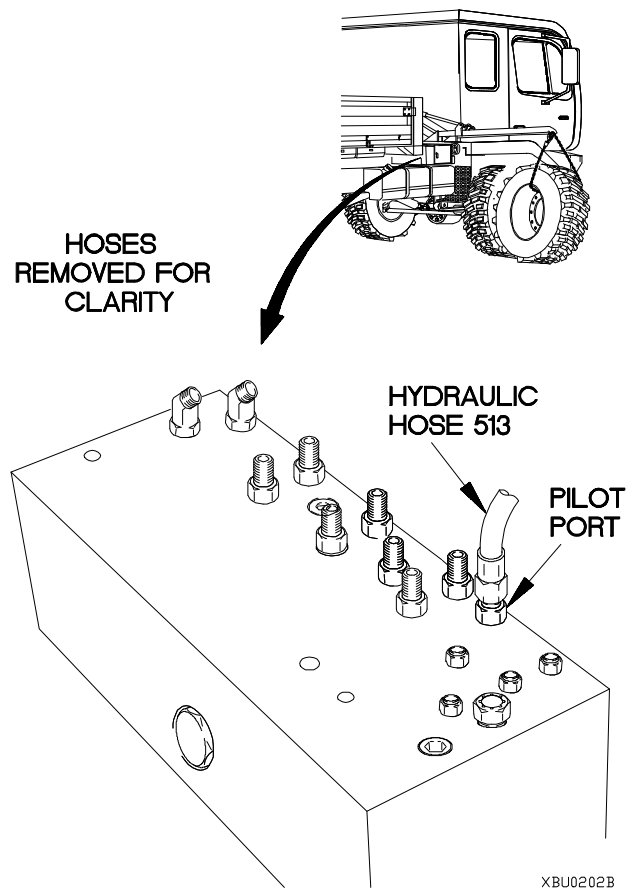

u2. SUSPENSION DOES NOT COMPRESS AND/OR RETURN TO NORMAL (CONT)

KNOWN INFO
Other hydraulic manifold functions OK. Hydraulic hoses free from leaks. Hydraulic hose 513 OK. Suspension release tee fitting OK. Suspension cylinders OK. Hydraulic hoses 509 and 511 OK.
POSSIBLE PROBLEMS
Faulty hydraulic hose(s) 508 and/or 510. Faulty suspension compression tee fitting. Faulty air/hydraulic manifold. Faulty hydraulic hose 512.

3.
Is 2,500-4,000 psi (17,238-27,580 kPa) present at suspension compression tee fitting output ports?

TEST OPTIONS
Pressure Test or STE/ICE-R Test #51
REASON FOR QUESTION
If 2,500-4,000 psi (17,238-27,580 kPa) is present, hydraulic hose(s) 508 and/or 510 is faulty.

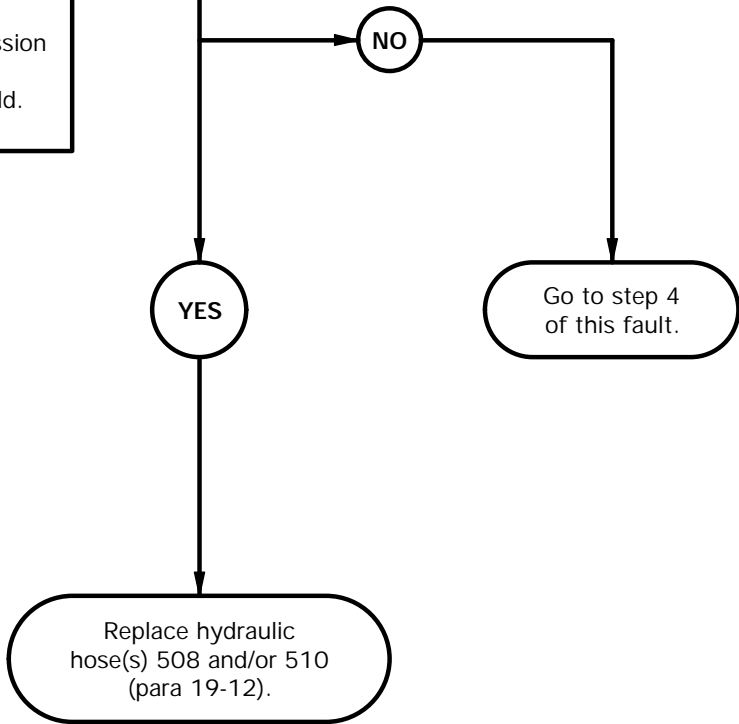

PRESSURE TEST

- (1) Position drain pan under suspension compression tee fitting.
- (2) Disconnect hydraulic hose 510 from suspension compression tee fitting LH output port.
- (3) Connect STE/ICE-R between hydraulic hose 510 and suspension compression tee fitting LH output port.
- (4) Start engine (TM 9-2320-366-10-1).
- (5) Position SUSPENSION knob to RAISE (TM 9-2320-366-10-1).
- (6) Position FUNCTION SELECT knob to SUSPENSION (TM 9-2320-366-10-1).
- (7) Push and hold PUMP plunger button (TM 9-2320-366-10-1) and perform STE/ICE-R Test #51.
- (8) If 2,500-4,000 psi (17,238-27,580 kPa) is not present, go to step 4 of this fault.
- (9) If 2,500-4,000 psi (17,238-27,580 kPa) is present, replace hydraulic hose 510 (para 19-12).
- (10) Disconnect STE/ICE-R from hydraulic hose 510 and suspension compression tee fitting LH output port.
- (11) Connect hydraulic hose 510 to suspension compression tee fitting LH output port.
- (12) Repeat steps (2) through (12) on hydraulic hose 508 and suspension compression tee fitting RH output port.

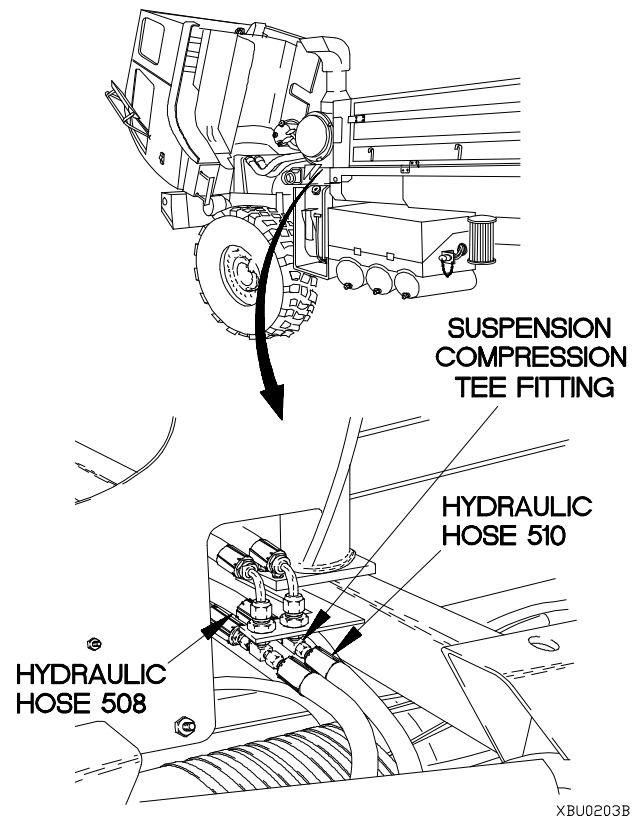

u2. SUSPENSION DOES NOT COMPRESS AND/OR RETURN TO NORMAL (CONT)

KNOWN INFO
Other hydraulic manifold functions OK. Hydraulic hoses free from leaks. Hydraulic hoses 508 and 510 OK. Hydraulic hose 513 OK. Suspension release tee fitting OK. Suspension cylinders OK. Hydraulic hoses 509 and 511 OK.
POSSIBLE PROBLEMS
Faulty suspension compression tee fitting. Faulty air/hydraulic manifold. Faulty hydraulic hose 512.

4.
Is 2,500-4,000 psi (17,238-27,580 kPa) present at suspension compression tee fitting input port?

TEST OPTIONS
Pressure Test or STE/ICE-R Test #51
REASON FOR QUESTION
If 2,500-4,000 psi (17,238-27,580 kPa) is present, suspension compression tee fitting is faulty.

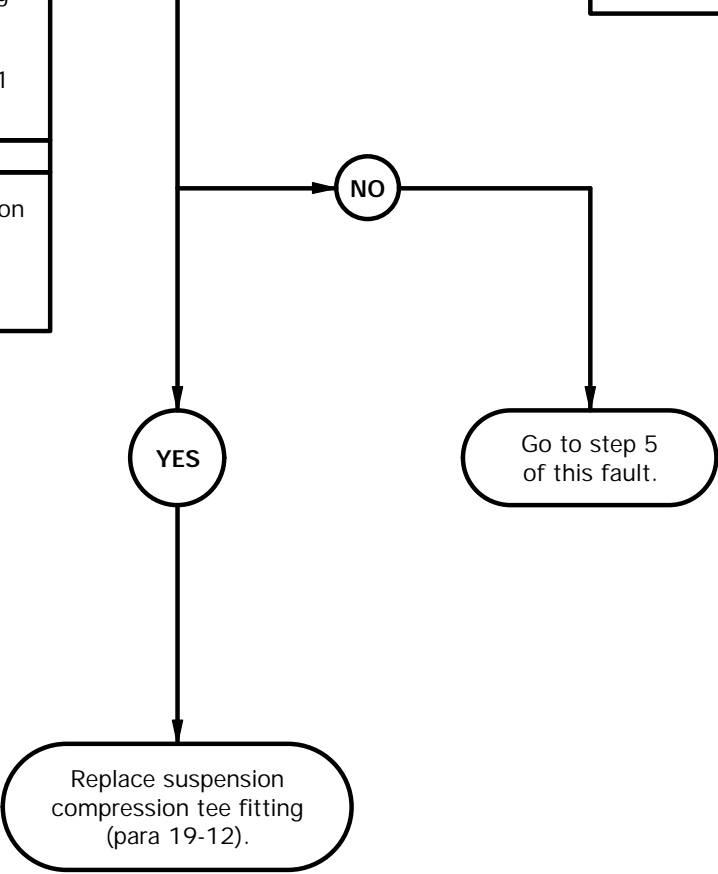

PRESSURE TEST

- (1) Disconnect hydraulic hose 512 from suspension compression tee fitting input port.
- (2) Connect STE/ICE-R between hydraulic hose 512 and suspension compression tee fitting input port.
- (3) Start engine (TM 9-2320-366-10-1).
- (4) Position SUSPENSION knob to RAISE (TM 9-2320-366-10-1).
- (5) Position FUNCTION SELECT knob to SUSPENSION (TM 9-2320-366-10-1).
- (6) Push and hold PUMP plunger button (TM 9-2320-366-10-1) and perform STE/ICE-R Test #51.
- (7) If 2,500-4,000 psi (17,238-27,580 kPa) is not present, go to step 5 of this fault.
- (8) If 2,500-4,000 psi (17,238-27,580 kPa) is present, replace suspension compression tee fitting (para 19-12).
- (9) Disconnect STE/ICE-R from hydraulic hose 512 and suspension compression tee fitting input port.
- (10) Connect hydraulic hose 512 to suspension compression tee fitting input port.

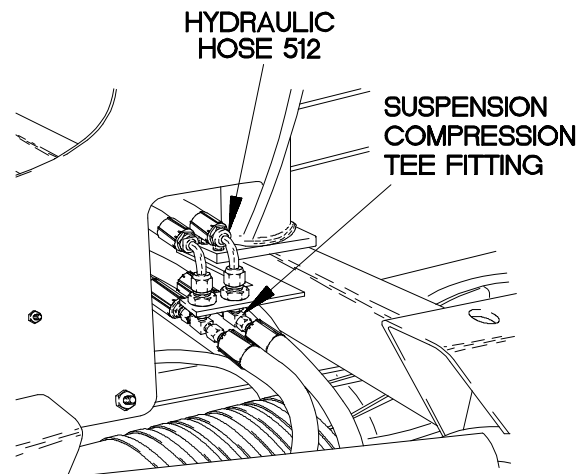

XBU0204B

u2. SUSPENSION DOES NOT COMPRESS AND/OR RETURN TO NORMAL (CONT)

KNOWN INFO
Other hydraulic manifold functions OK. Hydraulic hoses free from leaks. Hydraulic hoses 508 and 510 OK. Suspension compression tee fitting OK. Hydraulic hose 513 OK. Suspension release tee fitting OK. Suspension cylinders OK. Hydraulic hoses 509 and 511 OK.
POSSIBLE PROBLEMS
Faulty air/hydraulic manifold. Faulty hydraulic hose 512.

5.
Is 2,500-4,000 psi (17,238-27,580 kPa) present at SUSP COMPRESS output port?

TEST OPTIONS
Pressure Test or STE/ICE-R Test #51
REASON FOR QUESTION
If 2,500-4,000 psi (17,238-27,580 kPa) is not present, air/hydraulic manifold is faulty. If 2,500-4,000 psi (17,238-27,580 kPa) is present, hydraulic hose 512 is faulty.

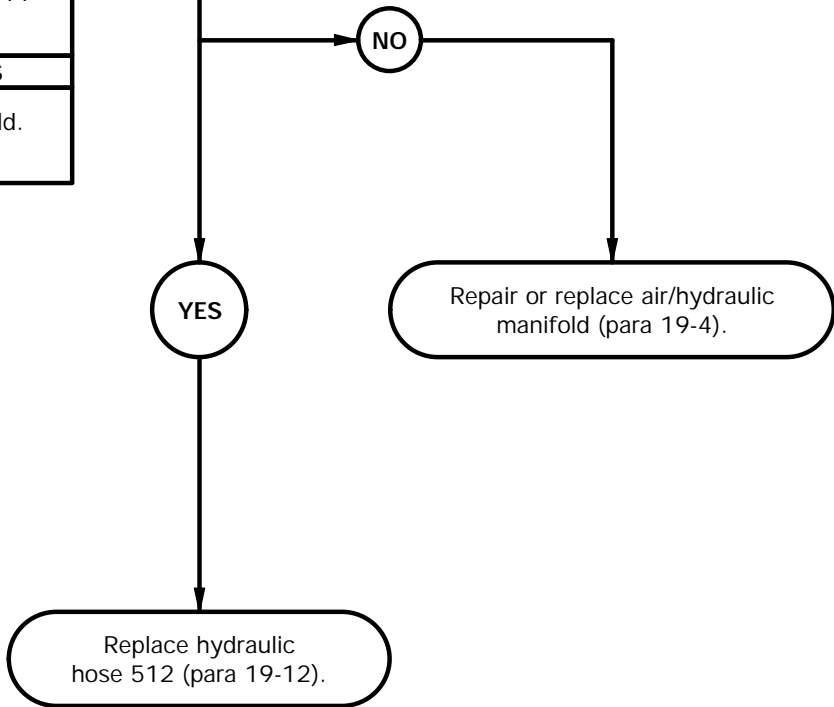

PRESSURE TEST

- (1) Position drain pan under air/hydraulic manifold
- (2) Disconnect hydraulic hose 512 from SUSP COMPRESS port.
- (3) Connect STE/ICE-R between hydraulic hose 512 and SUSP COMPRESS port.
- (4) Start engine (TM 9-2320-366-10-1).
- (5) Position SUSPENSION knob to RAISE (TM 9-2320-366-10-1).
- (6) Position FUNCTION SELECT knob to SUSPENSION (TM 9-2320-366-10-1).
- (7) Push and hold PUMP plunger button (TM 9-2320-366-10-1) and perform STE/ICE-R Test #51.
- (8) If 2,500-4,000 psi (17,238-27,580 kPa) is not present, repair or replace air/hydraulic manifold (para 19-4).
- (9) If 2,500-4,000 psi (17,238-27,580 kPa) is present, replace hydraulic hose 512 (para 19-12).
- (10) Disconnect STE/ICE-R from hydraulic hose 512 and SUSP COMPRESS port.
- (11) Connect hydraulic hose 512 to SUSP COMPRESS port.

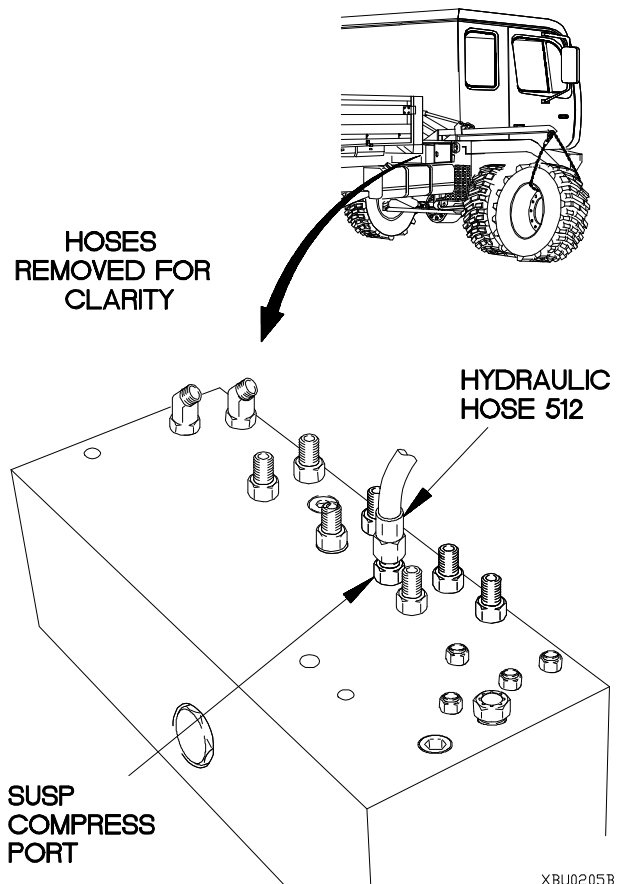

XBU0205B

u2. SUSPENSION DOES NOT COMPRESS AND/OR RETURN TO NORMAL (CONT)

KNOWN INFO
Other hydraulic manifold functions OK. Hydraulic hoses free from leaks. Hydraulic hoses 508 and 510 OK. Suspension compression tee fitting OK. Air/hydraulic manifold OK. Hydraulic hose 512 OK.
POSSIBLE PROBLEMS
Faulty hydraulic hose 513. Faulty suspension release tee fitting. Faulty suspension cylinder(s). Faulty hydraulic hose(s) 509 and/or 511.

6.
Is 2,500-4,000 psi (17,238-27,580 kPa) present at suspension release tee fitting output port?

TEST OPTIONS
Pressure Test or STE/ICE-R Test #51
REASON FOR QUESTION
If 2,500-4,000 psi (17,238-27,580 kPa) is present, hydraulic hose 513 is faulty.

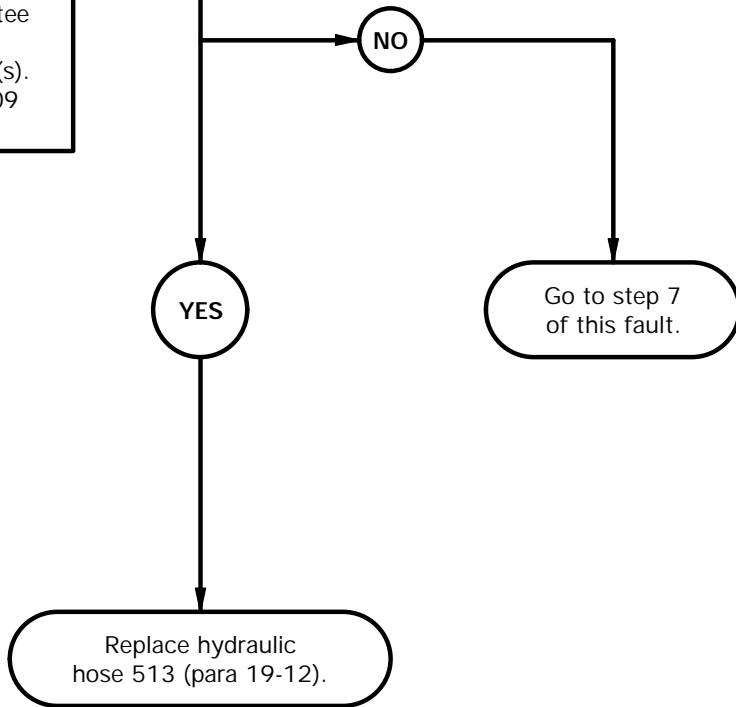

PRESSURE TEST

- (1) Position drain pan under suspension release tee fitting.
- (2) Disconnect hydraulic hose 513 from suspension release tee fitting output port.
- (3) Connect STE/ICE-R between hydraulic hose 513 and suspension release tee fitting output port.
- (4) Start engine (TM 9-2320-366-10-1).
- (5) Position SUSPENSION knob to LOWER (TM 9-2320-366-10-1).
- (6) Position FUNCTION SELECT knob to SUSPENSION (TM 9-2320-366-10-1).
- (7) Push and hold PUMP plunger button (TM 9-2320-366-10-1) and perform STE/ICE-R Test #51.
- (8) If 2,500-4,000 psi (17,238-27,580 kPa) is not present, go to step 7 of this fault.
- (9) If 2,500-4,000 psi (17,238-27,580 kPa) is present, replace hydraulic hose 513 (para 19-12).
- (10) Disconnect STE/ICE-R from hydraulic hose 513 and suspension release tee fitting output port.
- (11) Connect hydraulic hose 513 to suspension release tee fitting output port.

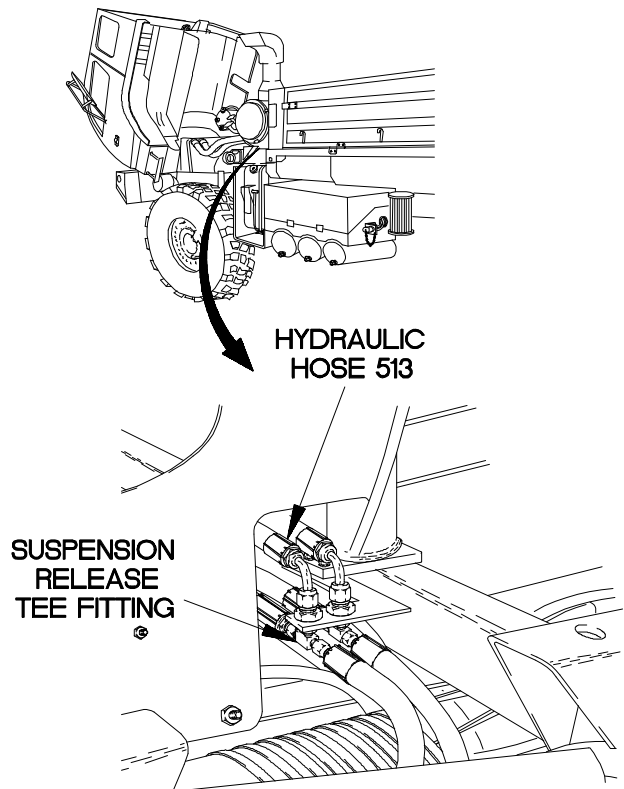

XBU0206B

u2. SUSPENSION DOES NOT COMPRESS AND/OR RETURN TO NORMAL (CONT)

KNOWN INFO
Other hydraulic manifold functions OK. Hydraulic hoses free from leaks. Hydraulic hoses 508 and 510 OK. Suspension compression tee fitting OK. Air/hydraulic manifold OK. Hydraulic hose 512 OK. Hydraulic hose 513 OK.
POSSIBLE PROBLEMS
Faulty suspension release tee fitting. Faulty suspension cylinder(s). Faulty hydraulic hose(s) 509 and/or 511.

7.
Is 2,500-4,000 psi (17,238-27,580 kPa) present at suspension release tee fitting input ports?

TEST OPTIONS
Pressure Test or STE/ICE-R Test #51
REASON FOR QUESTION
If 2,500-4,000 psi (17,238-27,580 kPa) is present, suspension release tee fitting is faulty.

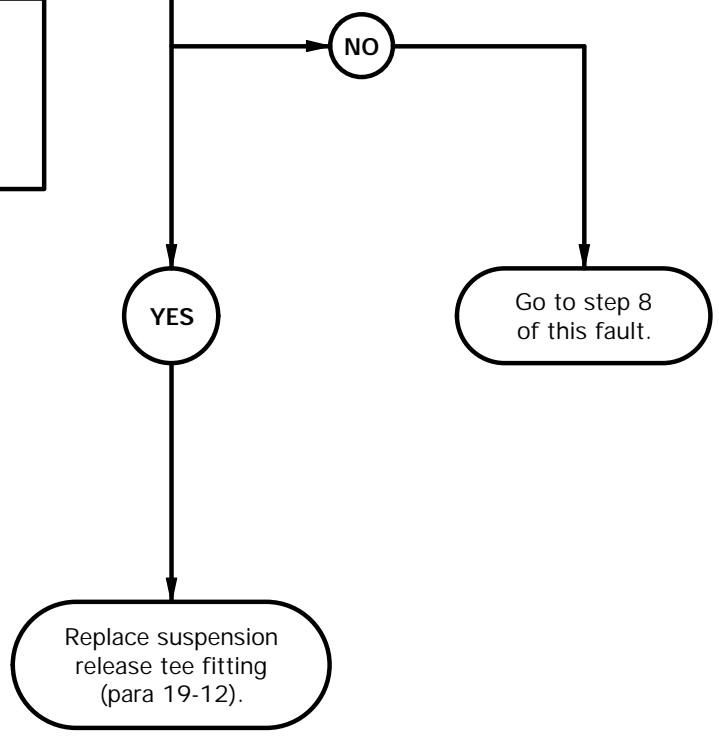

PRESSURE TEST

- (1) Disconnect hydraulic hose 511 from suspension release tee fitting LH input port.
- (2) Connect STE/ICE-R between hydraulic hose 511 and suspension release tee fitting LH input port.
- (3) Start engine (TM 9-2320-366-10-1).
- (4) Position SUSPENSION knob to LOWER (TM 9-2320-366-10-1).
- (5) Position FUNCTION SELECT knob to SUSPENSION (TM 9-2320-366-10-1).
- (6) Push and hold PUMP plunger button (TM 9-2320-366-10-1) and perform STE/ICE-R Test #51.
- (7) If 2,500-4,000 psi (17,238-27,580 kPa) is not present, go to step 5 of this fault.
- (8) If 2,500-4,000 psi (17,238-27,580 kPa) is present, replace hydraulic hose 511 (para 19-12).
- (9) Disconnect STE/ICE-R from hydraulic hose 511 and suspension release tee fitting LH input port.
- (10) Connect hydraulic hose 511 to suspension release tee fitting LH input port.
- (11) Repeat steps (2) through (12) on hydraulic hose 509 and suspension release tee fitting RH input port.

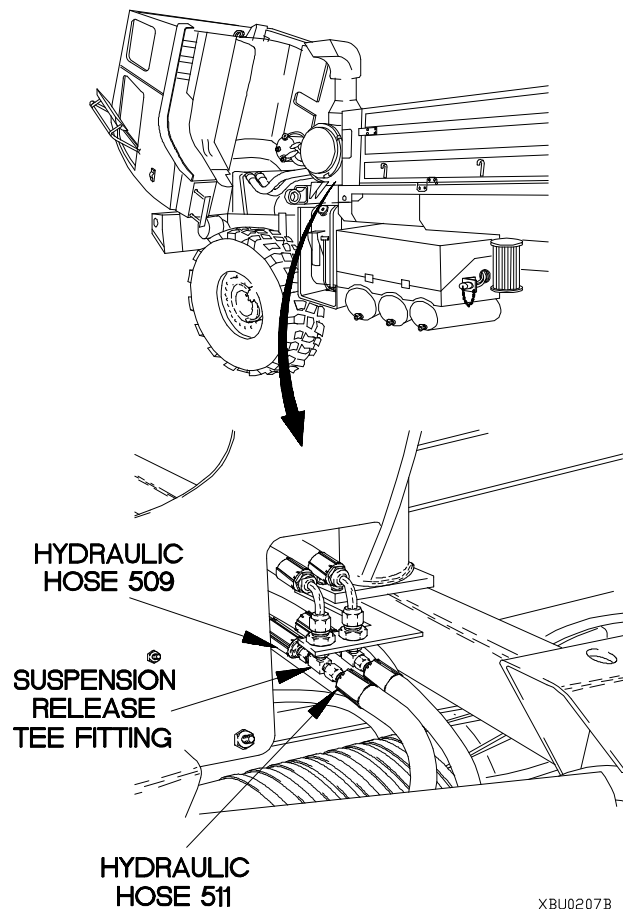

XBU0207B

u2. SUSPENSION DOES NOT COMPRESS AND/OR RETURN TO NORMAL (CONT)

KNOWN INFO
Other hydraulic manifold functions OK. Hydraulic hoses free from leaks. Hydraulic hoses 508 and 510 OK. Suspension compression tee fitting OK. Air/hydraulic manifold OK. Hydraulic hose 512 OK. Hydraulic hose 513 OK. Suspension release tee fitting OK.
POSSIBLE PROBLEMS
Faulty suspension cylinder(s). Faulty hydraulic hose(s) 509 and/or 511.

8.
Is 2,500-4,000 psi (17,238-27,580 kPa) present at suspension cylinder output ports?

TEST OPTIONS
Pressure Test or STE/ICE-R Test #51
REASON FOR QUESTION
If 2,500-4,000 psi (17,238-27,580 kPa) is not present, suspension cylinder(s) is faulty. If 2,500-4,000 psi (17,238-27,580 kPa) is present, hydraulic hose 509 and/or 511 is faulty.

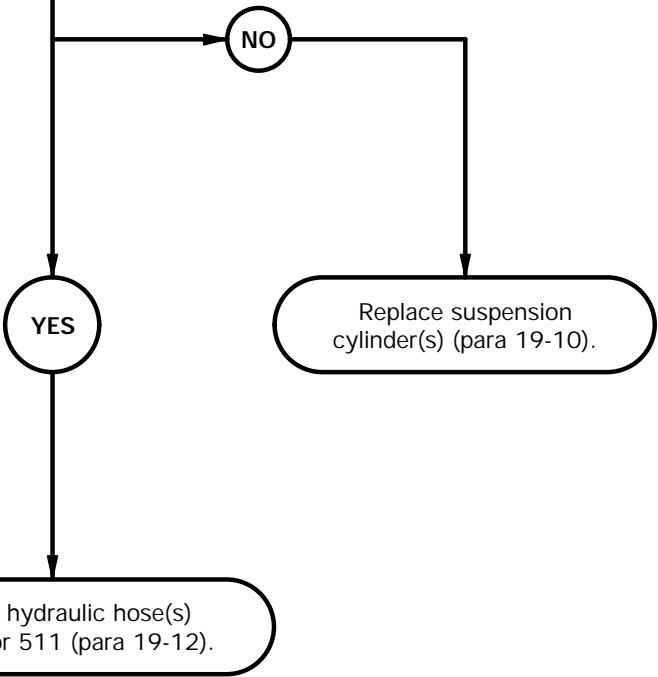

PRESSURE TEST

- (1) Position drain pan under RH suspension cylinder.
- (2) Disconnect hydraulic hose 509 from RH suspension cylinder output port.
- (3) Connect STE/ICE-R between hydraulic hose 509 and RH suspension cylinder output port.
- (4) Start engine (TM 9-2320-366-10-1).
- (5) Position SUSPENSION knob to RAISE (TM 9-2320-366-10-1).
- (6) Position FUNCTION SELECT knob to SUSPENSION (TM 9-2320-366-10-1).
- (7) Push and hold PUMP plunger button (TM 9-2320-366-10-1) and perform STE/ICE-R Test #51.
- (8) Shut down engine (TM 9-2320-366-10-1).
- (9) Disconnect STE/ICE-R from RH suspension cylinder output port and hydraulic hose 509.
- (10) Connect hydraulic hose 509 to RH suspension cylinder output port.
- (11) Repeat steps (1) through (10) on LH suspension cylinder and hydraulic hose 511.
- (12) If 2,500-4,000 psi (17,238-27,580 kPa) is not present, replace suspension cylinder(s) (para 19-10).
- (13) If 2,500-4,000 psi (17,238-27,580 kPa) is present, replace hydraulic hose(s) 509 and/or 511.

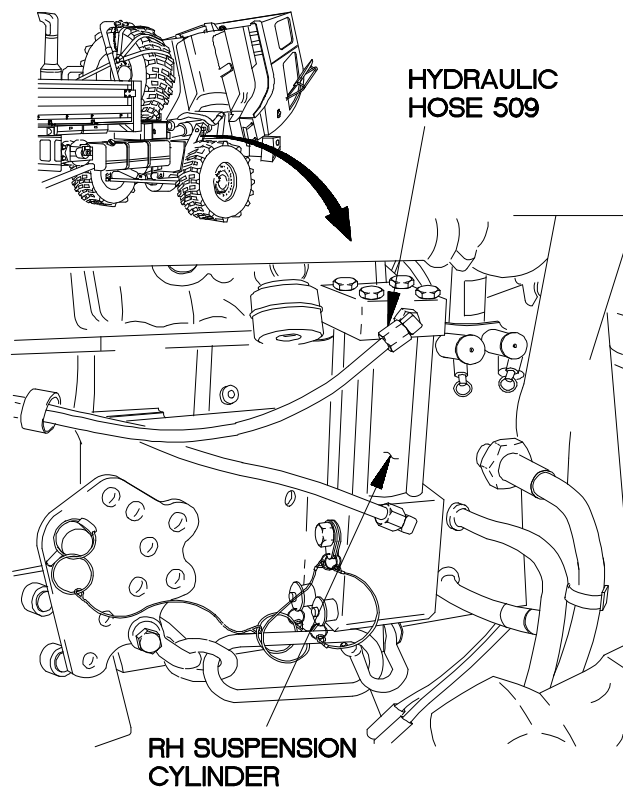

XBU0208B

u3. CAB LEVELING AIR SPRINGS DO NOT OPERATE

INITIAL SETUP

Equipment Condition

Engine shut down (TM 9-2320-366-10-1).

Personnel Required

(2)

Tools and Special Tools

Tool Kit, Genl Mech (Item 46, Appendix C)

Goggles, Industrial (Item 15, Appendix C)

References

TM 9-4910-571-12&P

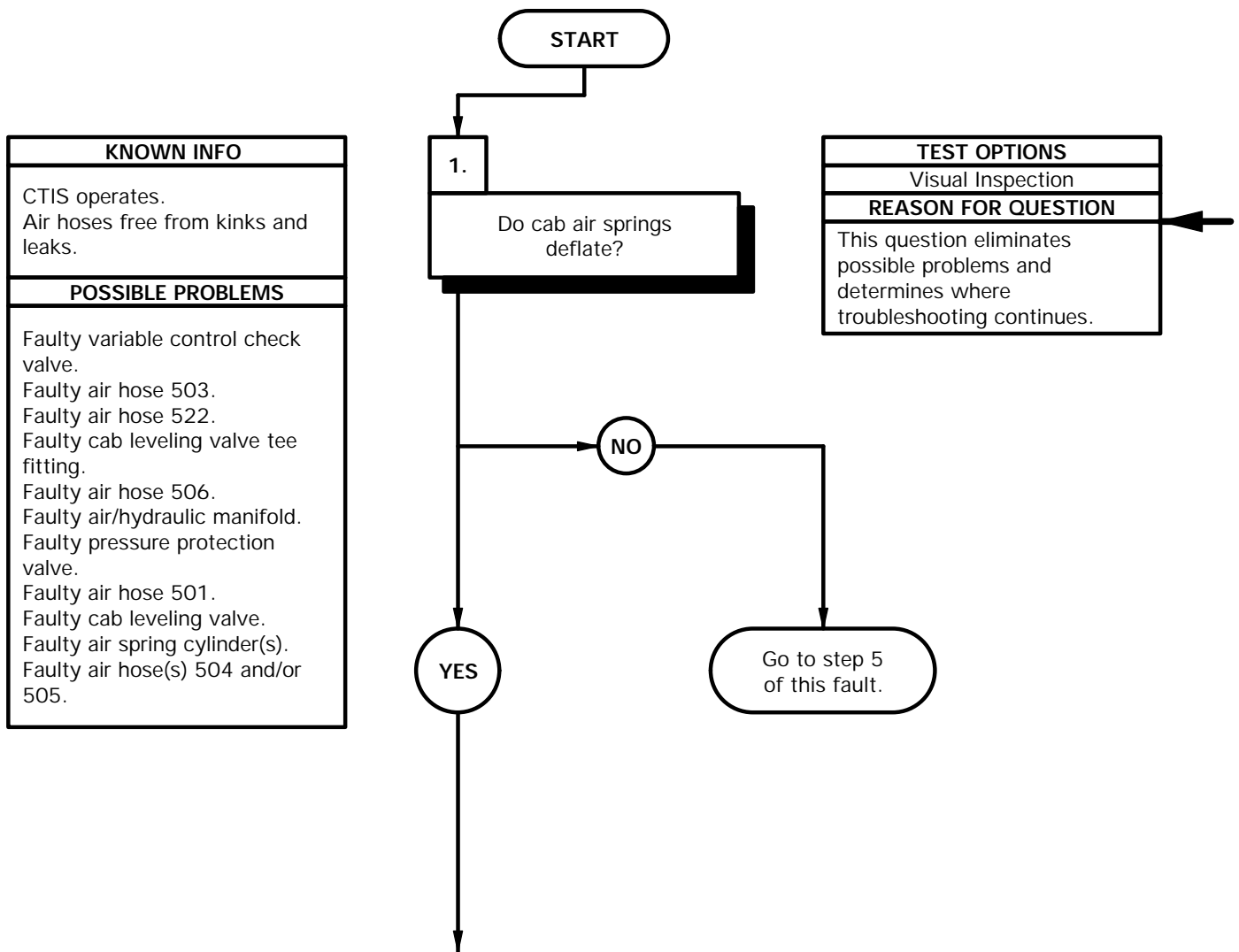

NOTE

SYSTEM PARK control must be engaged (TM 9-2320-366-10-1) before operating SUSPENSION compression.

- (1) Attempt to deflate cab air springs (TM 9-2320-366-10-1).
- (2) If cab air springs do not deflate, go to step 5 of this fault.

u3. CAB LEVELING AIR SPRINGS DO NOT OPERATE (CONT)

KNOWN INFO
CTIS operates. Air hoses free from kinks and leaks. Air hose 522 OK. Air hose 506 OK. Air/hydraulic manifold OK. Pressure protection valve OK. Air hose 501 OK.
POSSIBLE PROBLEMS
Faulty variable control check valve. Faulty air hose 503. Faulty cab leveling valve tee fitting. Faulty cab leveling valve. Faulty air spring cylinder(s). Faulty air hose(s) 504 and/or 505.

KNOWN INFO
CTIS operates. Air hoses free from kinks and leaks. Air hose 522 OK. Air hose 506 OK. Air/hydraulic manifold OK. Pressure protection valve OK. Air hose 501 OK. Cab leveling valve OK. Air spring cylinders OK. Air hoses 504 and 505 OK.
POSSIBLE PROBLEMS
Faulty variable control check valve. Faulty air hose 503. Faulty cab leveling valve tee fitting.

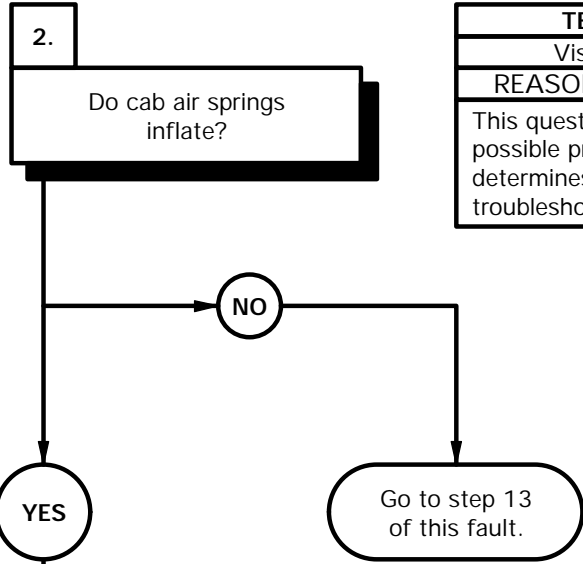

TEST OPTIONS
Visual Inspection
REASON FOR QUESTION
This question eliminates possible problems and determines where troubleshooting continues.

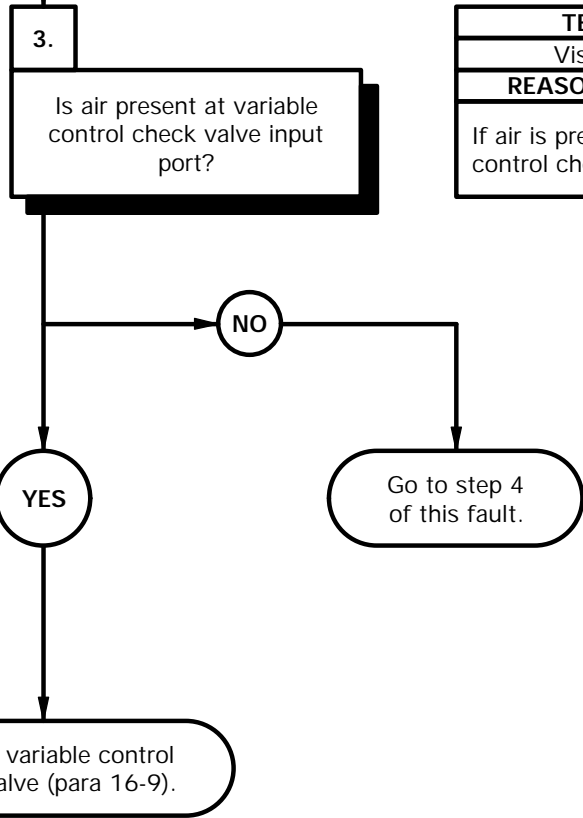

TEST OPTIONS
Visual Inspection
REASON FOR QUESTION
If air is present, variable control check valve is faulty.

- (1) Attempt to inflate cab air springs (TM 9-2320-366-10-1).
- (2) If cab air springs do not inflate, go to step 13 of this fault.

- (1) Start engine and allow air tanks to pressurize (TM 9-2320-366-10-1).
- (2) Shut down engine (TM 9-2320-366-10-1).
- (3) Raise cab (TM 9-2320-366-10-1).
- (4) Loosen air hose 503 at variable control check valve input port.
- (5) Check for pressure of air at air hose 503.
- (6) Tighten air hose 503 to variable control check valve.
- (7) If air is not present, go to step 4 of this fault.
- (8) If air is present, replace variable control check valve (para 16-9).

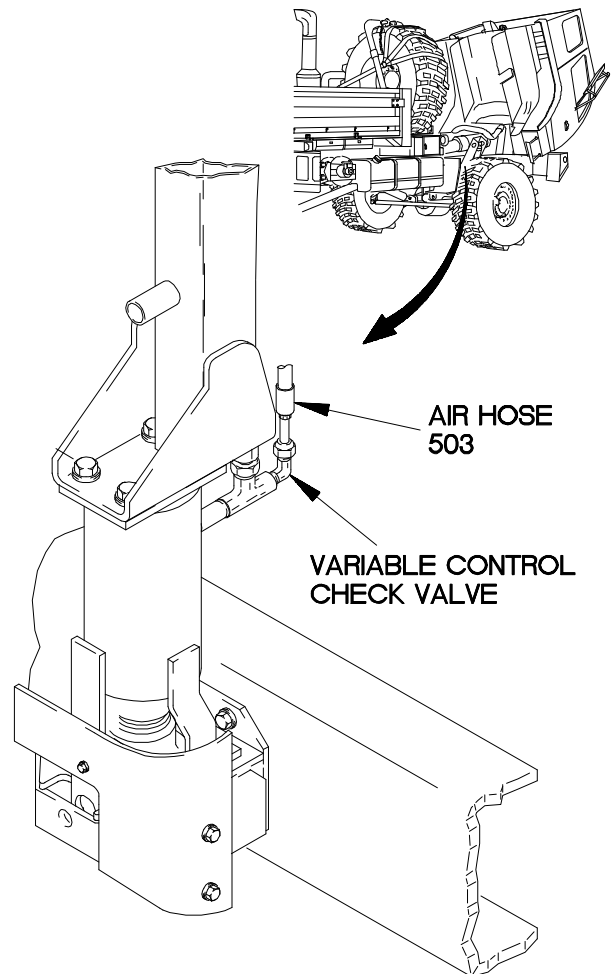

Xbu0301b

u3. CAB LEVELING AIR SPRINGS DO NOT OPERATE (CONT)

KNOWN INFO
CTIS operates. Air hoses free from kinks and leaks. Variable control check valve OK. Air hose 522 OK. Air hose 506 OK. Air/hydraulic manifold OK. Pressure protection valve OK. Air hose 501 OK. Cab leveling valve OK. Air spring cylinders OK. Air hoses 504 and 505 OK.
POSSIBLE PROBLEMS
Faulty air hose 503. Faulty cab leveling valve tee fitting.

4.
 Is air present at cab leveling valve tee fitting check valve output port?

TEST OPTIONS
Visual Inspection
REASON FOR QUESTION
If air is not present, cab leveling valve tee fitting. If air is present, air hose 503 is faulty.

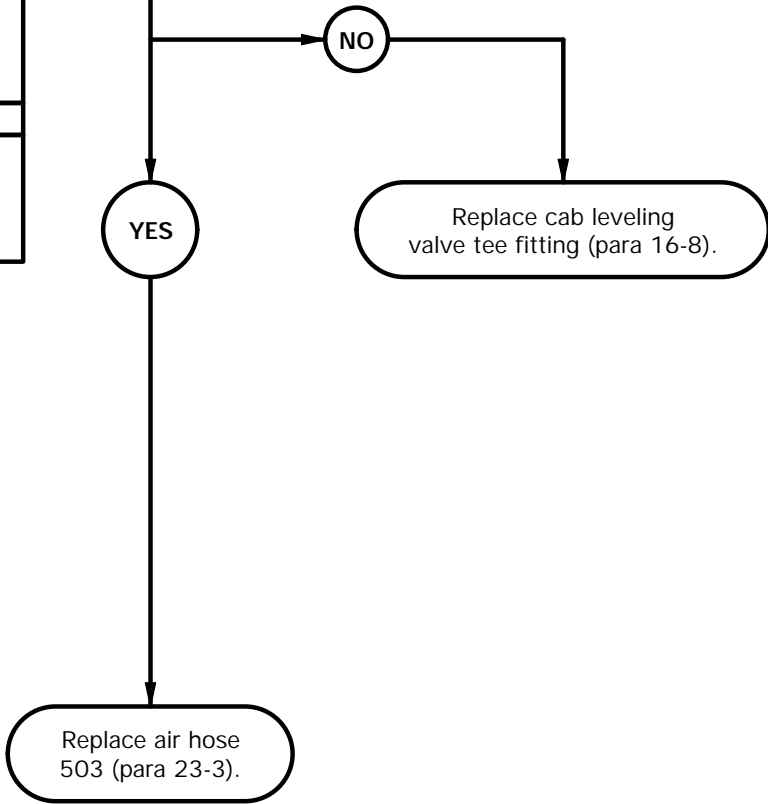

- (1) Loosen air hose 503 at cab leveling valve tee fitting check valve output port.
- (2) Check for pressure of air at cab leveling valve tee fitting check valve output port.
- (3) Tighten air hose 503 at cab leveling valve tee fitting check valve output port.
- (4) If air is not present, replace cab leveling valve tee fitting (para 16-8).
- (5) If air is present, replace air hose 503 (para 23-3).

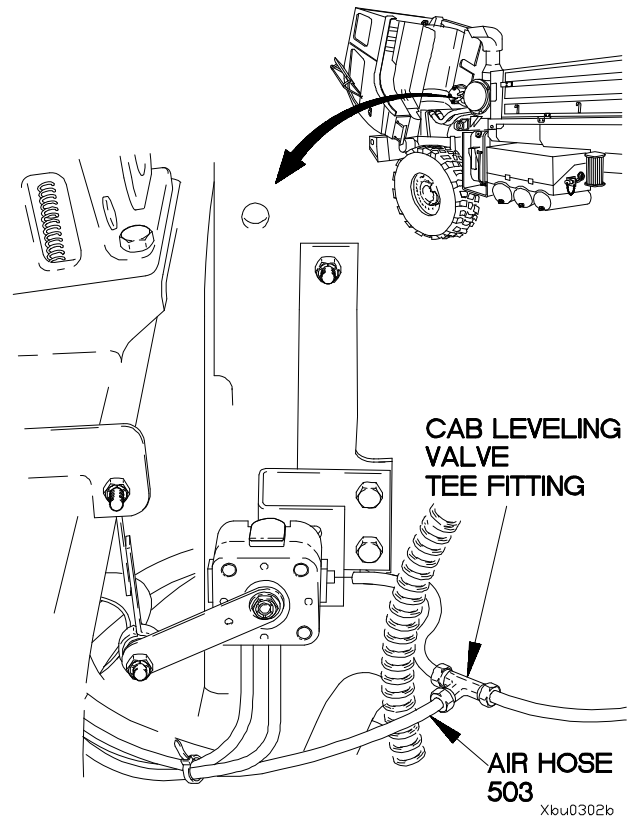

u3. CAB LEVELING AIR SPRINGS DO NOT OPERATE (CONT)

KNOWN INFO
CTIS operates. Air hoses free from kinks and leaks. Variable control check valve OK. Air hose 503 OK.
POSSIBLE PROBLEMS
Faulty air hose 522. Faulty cab leveling valve tee fitting. Faulty air hose 506. Faulty air/hydraulic manifold. Faulty pressure protection valve. Faulty air hose 501. Faulty cab leveling valve. Faulty air spring cylinder(s). Faulty air hose(s) 504 and/or 505.

5.
Is air present at air spring cylinder input ports?

TEST OPTIONS
Visual Inspection
REASON FOR QUESTION
If air is present, air spring cylinder(s) is faulty.

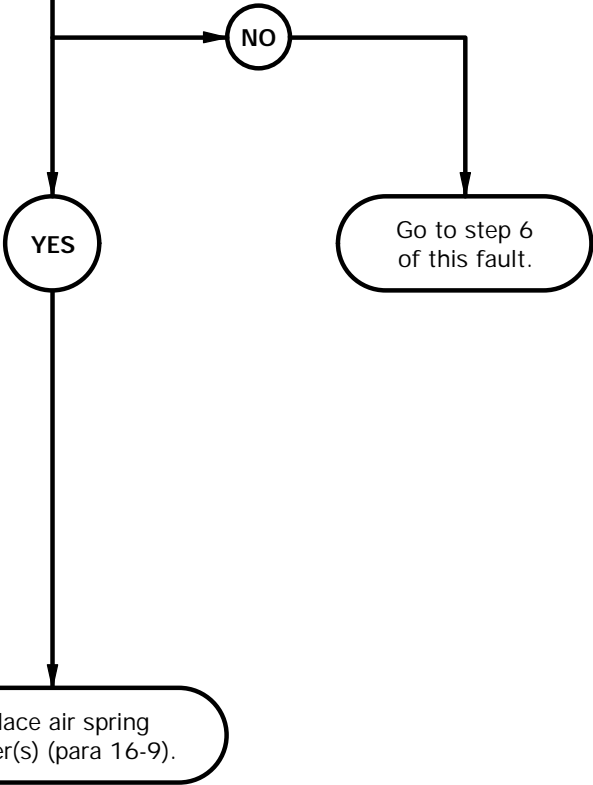

- (1) Start engine and allow air tanks to pressurize (TM 9-2320-366-10-1).
- (2) Shut down engine (TM 9-2320-366-10-1).
- (3) Raise cab (TM 9-2320-366-10-1).
- (4) Loosen air hose 504 at RH air spring cylinder.
- (5) Turn CAB knob to the right and push in (TM 9-2320-366-10-1).
- (6) Check for presence of air at air hose 504.
- (7) Turn CAB knob to the left (TM 9-2320-366-10-1).
- (8) Tighten air hose 504 at RH air spring cylinder.
- (9) Repeat steps (4) through (8) on LH air spring cylinder and air hose 505.
- (10) If air is not present, go to step 6 of this fault.
- (11) If air is present, replace air spring cylinder(s) (para 16-9).

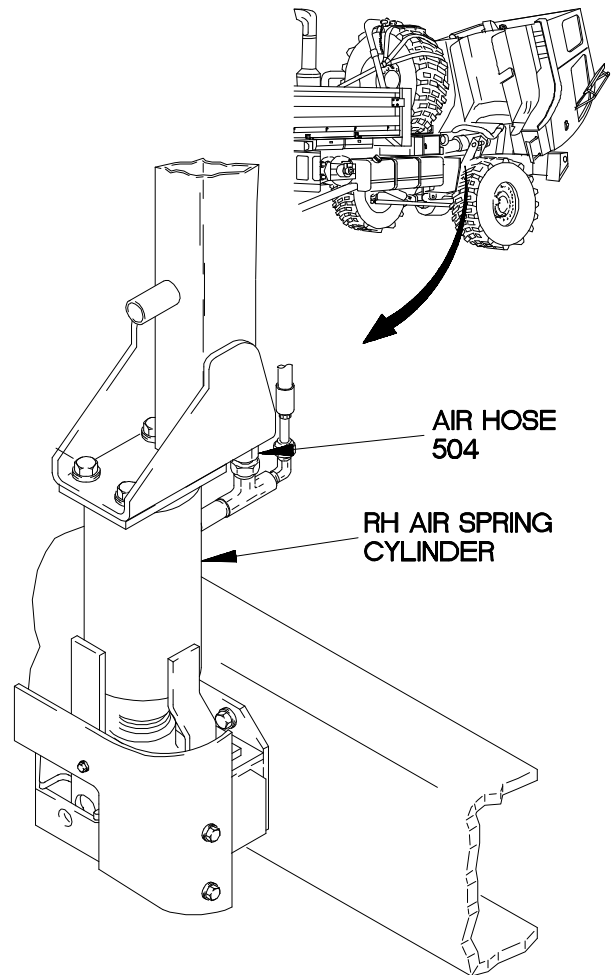

Xbu0303b

u3. CAB LEVELING AIR SPRINGS DO NOT OPERATE (CONT)

KNOWN INFO
CTIS operates. Air hoses free from kinks and leaks. Variable control check valve OK. Air hose 503 OK. Air spring cylinders OK.
POSSIBLE PROBLEMS
Faulty air hose 522. Faulty cab leveling valve tee fitting. Faulty air hose 506. Faulty air/hydraulic manifold. Faulty pressure protection valve. Faulty air hose 501. Faulty cab leveling valve. Faulty air hose(s) 504 and/or 505.

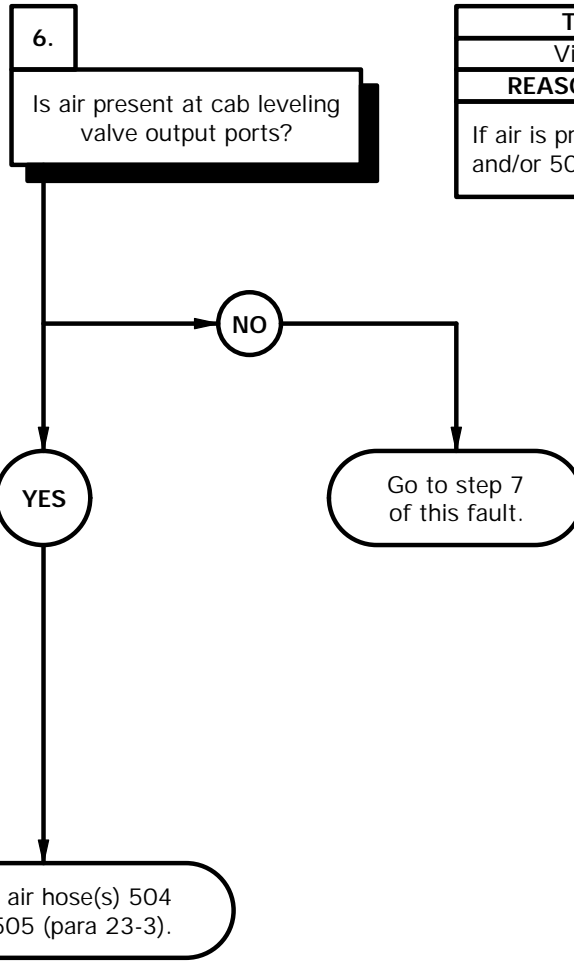

TEST OPTIONS
Visual Inspection
REASON FOR QUESTION
If air is present, air hose(s) 504 and/or 505 is faulty.



- (1) Loosen air hoses 504 and 505 at cab leveling valve output ports.
- (2) Turn CAB knob to the right and push in (TM 9-2320-366-10-1).
- (3) Check for presence of air at cab leveling valve output ports.
- (4) Turn CAB knob to the left (TM 9-2320-366-10-1).
- (5) Tighten air hoses 504 and 505 at cab leveling valve output ports.
- (6) If air is not present, go to step 7 of this fault.
- (7) If air is present, replace air hose(s) 504 and/or 505 (para 23-3).

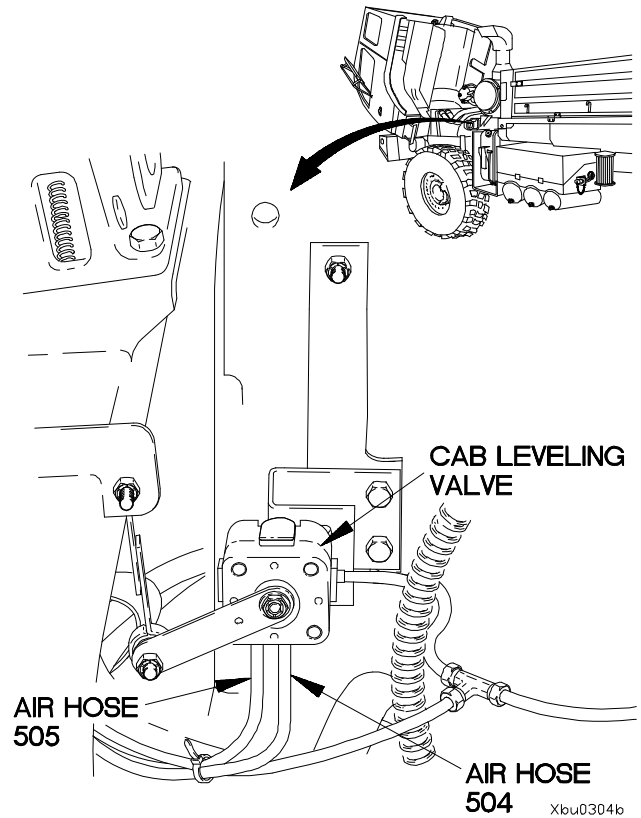

u3. CAB LEVELING AIR SPRINGS DO NOT OPERATE (CONT)

KNOWN INFO
CTIS operates. Air hoses free from kinks and leaks. Variable control check valve OK. Air hose 503 OK. Air spring cylinders OK. Air hoses 504 and 505 OK.
POSSIBLE PROBLEMS
Faulty air hose 522. Faulty cab leveling valve tee fitting. Faulty air hose 506. Faulty air/hydraulic manifold. Faulty pressure protection valve. Faulty air hose 501. Faulty cab leveling valve.

7.
Is air present at cab leveling valve input port?

TEST OPTIONS
Visual Inspection
REASON FOR QUESTION
If air is present, cab leveling valve is faulty.

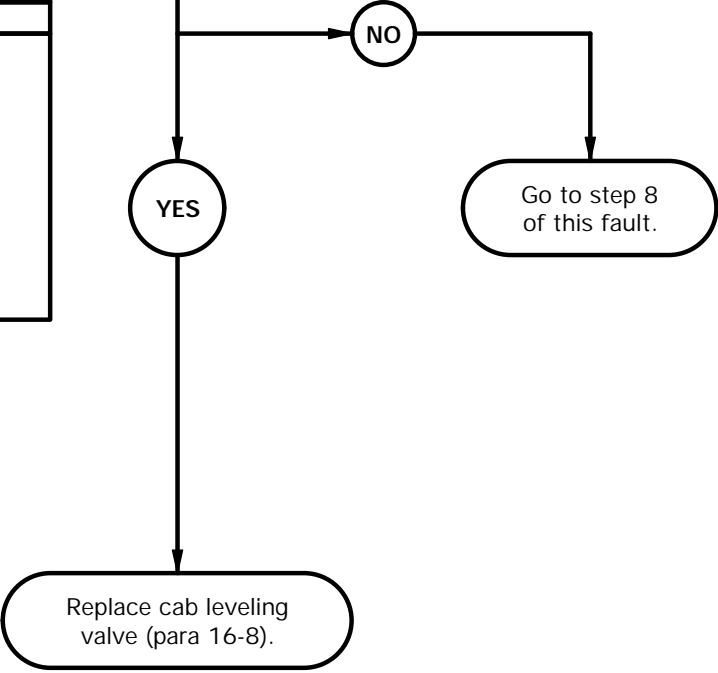

- (1) Loosen air hose 522 at cab leveling valve input port.
- (2) Turn CAB knob to the right and push in (TM 9-2320-366-10-1).
- (3) Check for presence of air at air hose 522.
- (4) Turn CAB knob to the left (TM 9-2320-366-10-1).
- (5) Tighten air hose 522 at cab leveling valve input port.
- (6) If air is not present, go to step 8 of this fault.
- (7) If air is present, replace cab leveling valve (para 16-8).

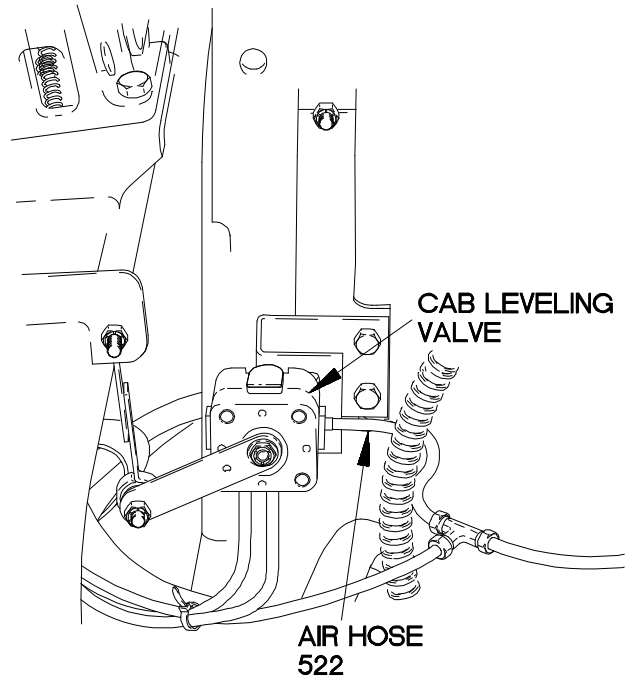

Xbu0305b

u3. CAB LEVELING AIR SPRINGS DO NOT OPERATE (CONT)

KNOWN INFO
CTIS operates. Air hoses free from kinks and leaks. Variable control check valve OK. Air hose 503 OK. Cab leveling valve OK. Air spring cylinders OK. Air hoses 504 and 505 OK.
POSSIBLE PROBLEMS
Faulty air hose 522 Faulty cab leveling valve tee fitting. Faulty air hose 506. Faulty air/hydraulic manifold. Faulty pressure protection valve. Faulty air hose 501.

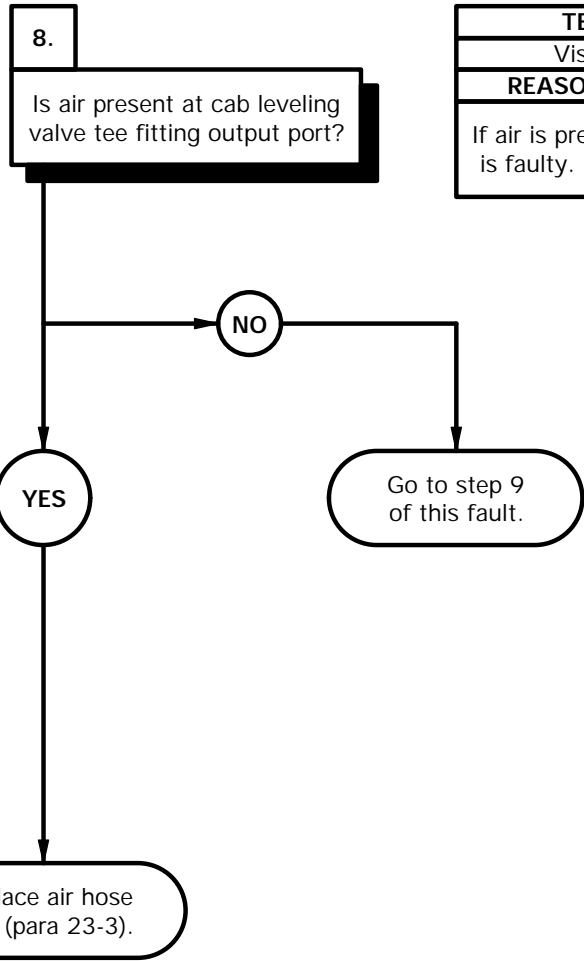

TEST OPTIONS
Visual Inspection
REASON FOR QUESTION
If air is present, air hose 522 is faulty.



- (1) Loosen air hose 522 at cab leveling valve tee fitting output port.
- (2) Turn CAB knob to the right and push in (TM 9-2320-366-10-1).
- (3) Check for presence of air at cab leveling valve tee fitting output port.
- (4) Turn CAB knob to the left (TM 9-2320-366-10-1).
- (5) Tighten air hose 522 at cab leveling valve tee fitting output port.
- (6) If air is not present, go to step 9 of this fault.
- (7) If air is present, replace cab leveling valve tee fitting (para 16-8).

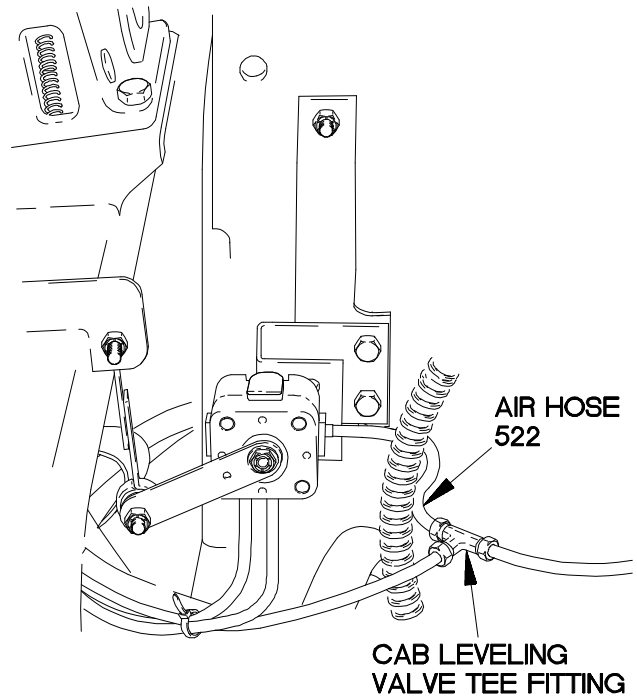

Xbu0306b

u3. CAB LEVELING AIR SPRINGS DO NOT OPERATE (CONT)

KNOWN INFO
CTIS operates. Air hoses free from kinks and leaks. Variable control check valve OK. Air hose 503 OK. Air hose 522 OK. Cab leveling valve OK. Air spring cylinders OK. Air hoses 504 and 505 OK.
POSSIBLE PROBLEMS
Faulty cab leveling valve tee fitting. Faulty air hose 506. Faulty air/hydraulic manifold. Faulty pressure protection valve. Faulty air hose 501.

9.
 Is air present at cab leveling valve tee fitting input port?

TEST OPTIONS
Visual Inspection
REASON FOR QUESTION
If air is present, cab leveling valve tee fitting is faulty.

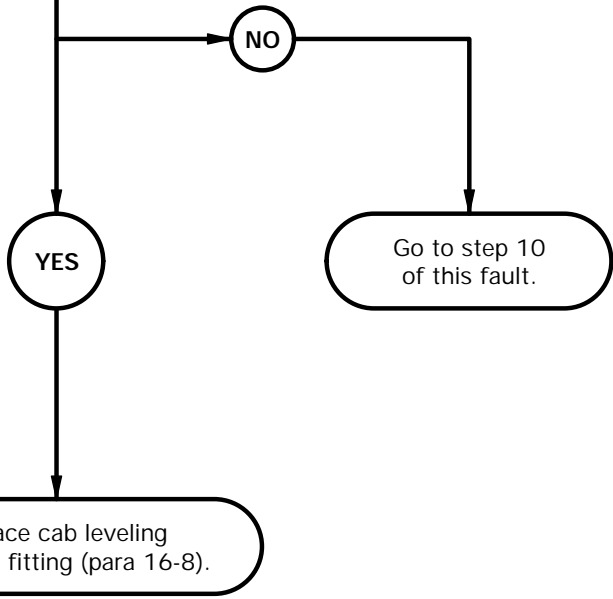

- (1) Loosen air hose 506 at cab leveling valve tee fitting input port.
- (2) Turn CAB knob to the right and push in (TM 9-2320-366-10-1).
- (3) Check for presence of air at air hose 506.
- (4) Turn CAB knob to the left (TM 9-2320-366-10-1).
- (5) Tighten air hose 506 at cab leveling valve tee fitting input port.
- (6) If air is not present, go to step 10 of this fault.
- (7) If air is present, replace cab leveling valve tee fitting (para 16-8).

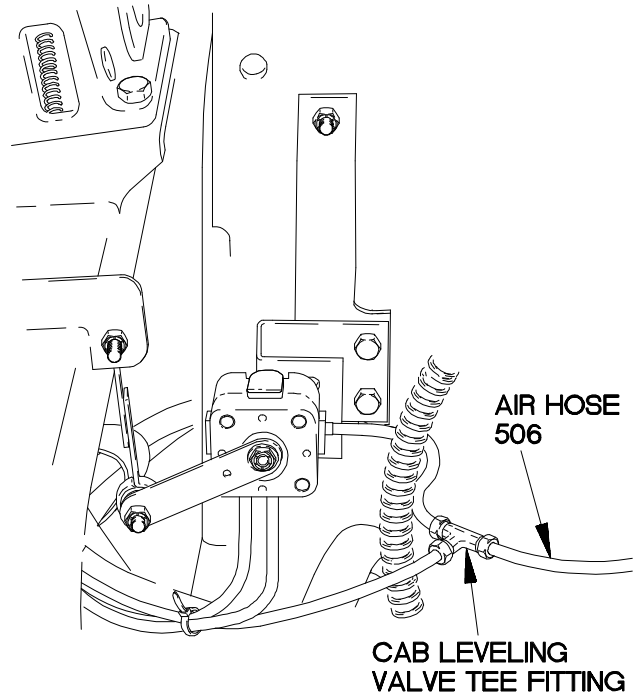

Xbu0307b

u3. CAB LEVELING AIR SPRINGS DO NOT OPERATE (CONT)

KNOWN INFO
CTIS operates. Air hoses free from kinks and leaks. Variable control check valve OK. Air hose 503 OK. Air hose 522 OK. Cab leveling valve tee fitting OK. Cab leveling valve OK. Air spring cylinders OK. Air hoses 504 and 505 OK.
POSSIBLE PROBLEMS
Faulty air hose 506. Faulty air/hydraulic manifold. Faulty pressure protection valve. Faulty air hose 501.

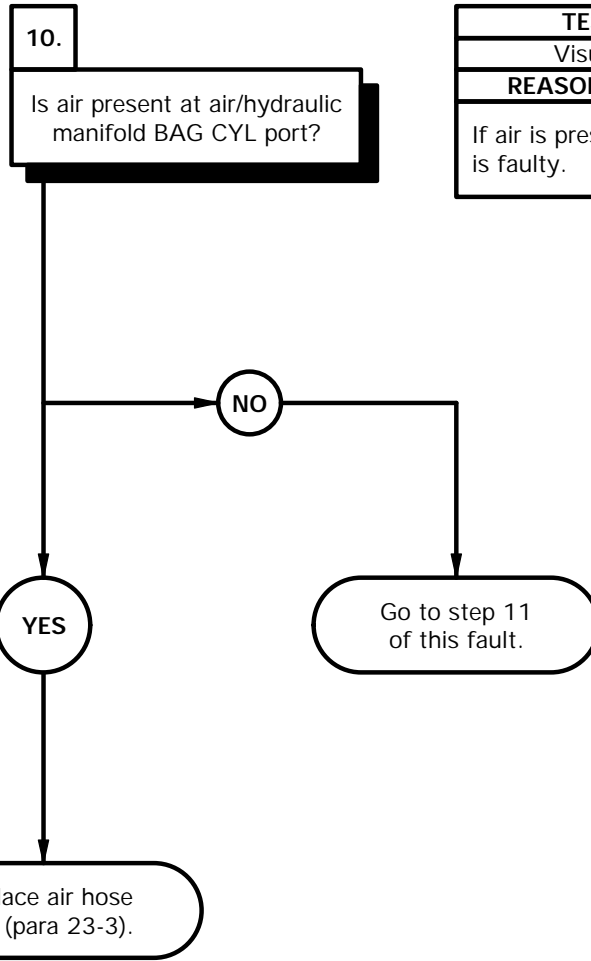

TEST OPTIONS
Visual Inspection
REASON FOR QUESTION
If air is present, air hose 506 is faulty.



- (1) Loosen air hose 506 at air/hydraulic manifold BAG CYL port.
- (2) Turn CAB knob to the right and push in (TM 9-2320-366-10-1).
- (3) Check for presence of air at air/hydraulic manifold BAG CYL port.
- (4) Turn CAB knob to the left (TM 9-2320-366-10-1).
- (5) Tighten air hose 506 at air/hydraulic manifold BAG CYL port.
- (6) If air is not present, go to step 11 of this fault.
- (7) If air is present, replace air hose 506 (para 23-3).

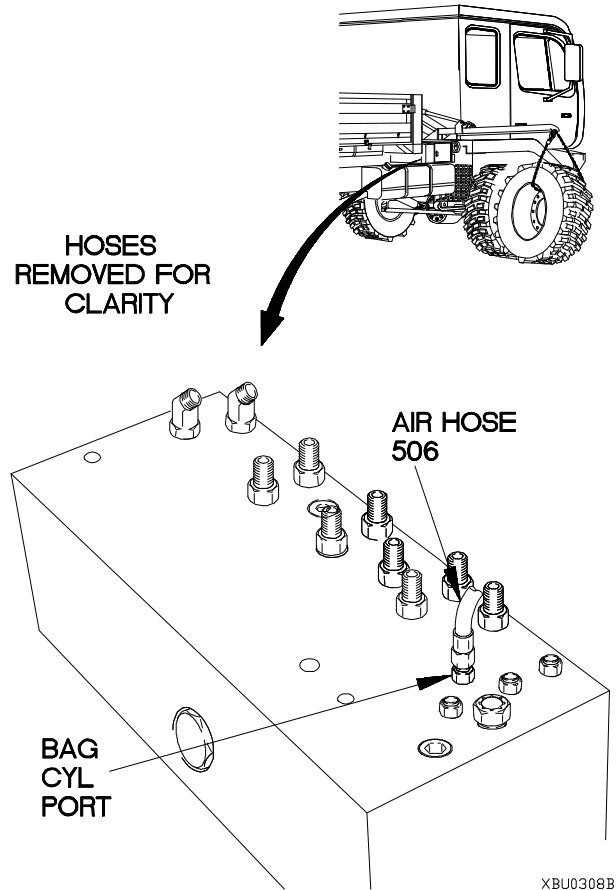

u3. CAB LEVELING AIR SPRINGS DO NOT OPERATE (CONT)

KNOWN INFO
CTIS operates. Air hoses free from kinks and leaks. Variable control check valve OK. Air hose 503 OK. Air hose 522 OK. Cab leveling valve tee fitting OK. Air hose 506 OK. Cab leveling valve OK. Air spring cylinders OK. Air hoses 504 and 505 OK.
POSSIBLE PROBLEMS
Faulty air/hydraulic manifold. Faulty pressure protection valve. Faulty air hose 501.

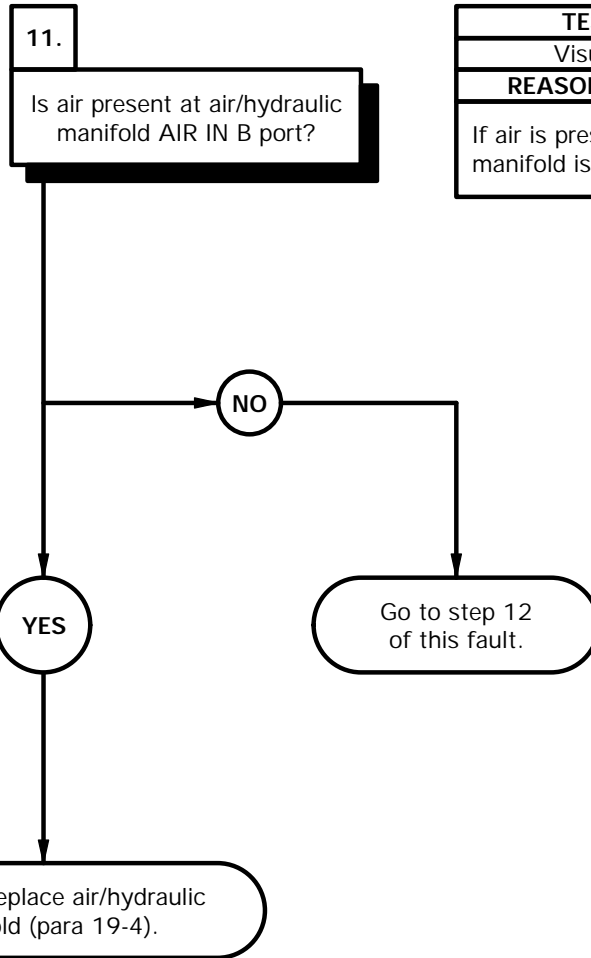

TEST OPTIONS
Visual Inspection
REASON FOR QUESTION
If air is present, air/hydraulic manifold is faulty.



- (1) Loosen air hose 501 at air/hydraulic manifold AIR IN B port.
- (2) Check for presence of air at air hose 501.
- (3) Tighten air hose 501 at air/hydraulic manifold AIR IN B port.
- (4) If air is not present, go to step 12 of this fault.
- (5) If air is present, repair or replace air/hydraulic manifold (para 19-4).

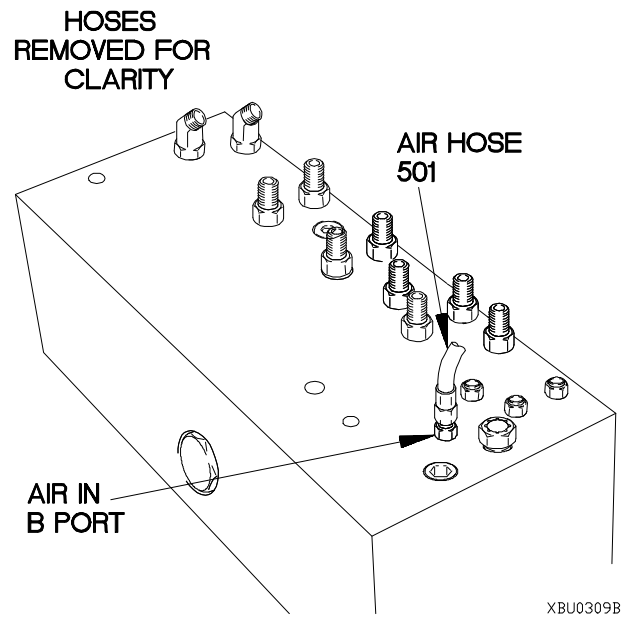

u3. CAB LEVELING AIR SPRINGS DO NOT OPERATE (CONT)

KNOWN INFO
CTIS operates. Air hoses free from kinks and leaks. Variable control check valve OK. Air hose 503 OK. Air hose 522 OK. Cab leveling valve tee fitting OK. Air hose 506 OK. Cab leveling valve OK. Air spring cylinders OK. Air hoses 504 and 505 OK. Air/hydraulic manifold OK.
POSSIBLE PROBLEMS
Faulty pressure protection valve. Faulty air hose 501.

12.
 Is air present at pressure protection valve output port?

TEST OPTIONS
Visual Inspection
REASON FOR QUESTION
If air is not present, pressure protection valve is faulty. If air is present, air hose 501 is faulty.

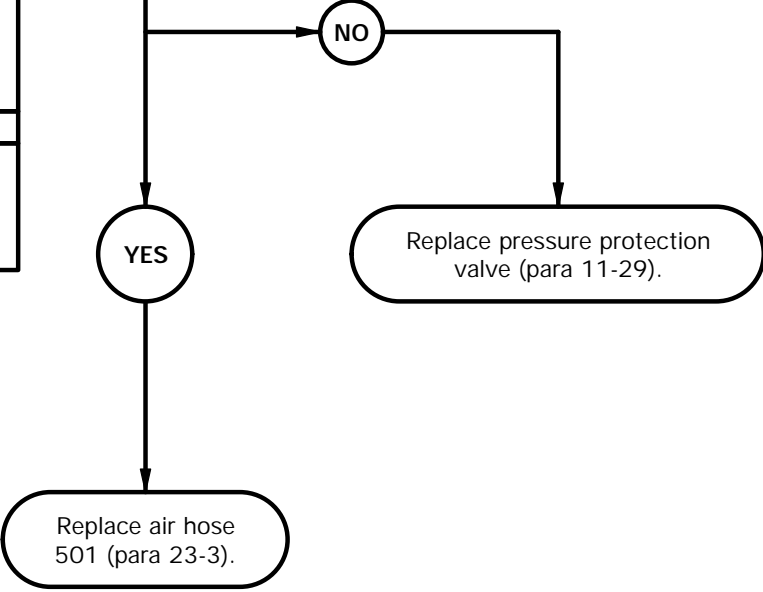

- (1) Loosen air hose 501 at pressure protection valve output port.
- (2) Check for presence of air at pressure protection valve output port.
- (3) Tighten air hose 501 at pressure protection valve output port.
- (4) If air is not present, replace pressure protection valve (para 11-29).
- (5) If air is present, replace air hose 501 (para 23-3).

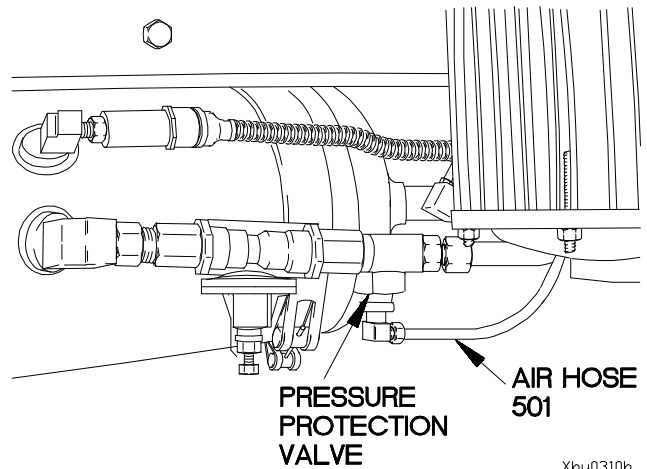
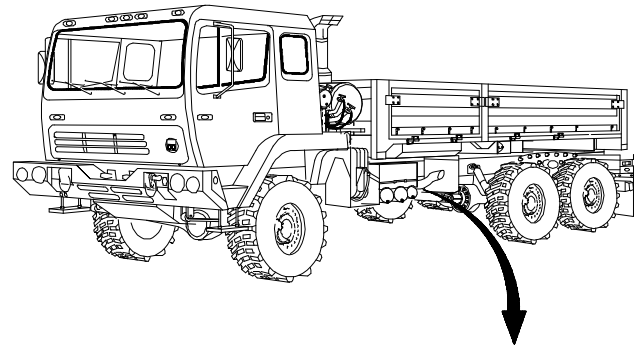

Xbu0310b

u3. CAB LEVELING AIR SPRINGS DO NOT OPERATE (CONT)

KNOWN INFO
CTIS operates. Air hoses free from kinks and leaks. Variable control check valve OK. Air hose 503 OK. Air hose 522 OK. Cab leveling valve tee fitting OK. Air hose 506 OK. Air/hydraulic manifold OK. Pressure protection valve OK. Air hose 501 OK.
POSSIBLE PROBLEMS
Faulty cab leveling valve. Faulty air spring cylinder(s). Faulty air hose(s) 504 and/or 505.

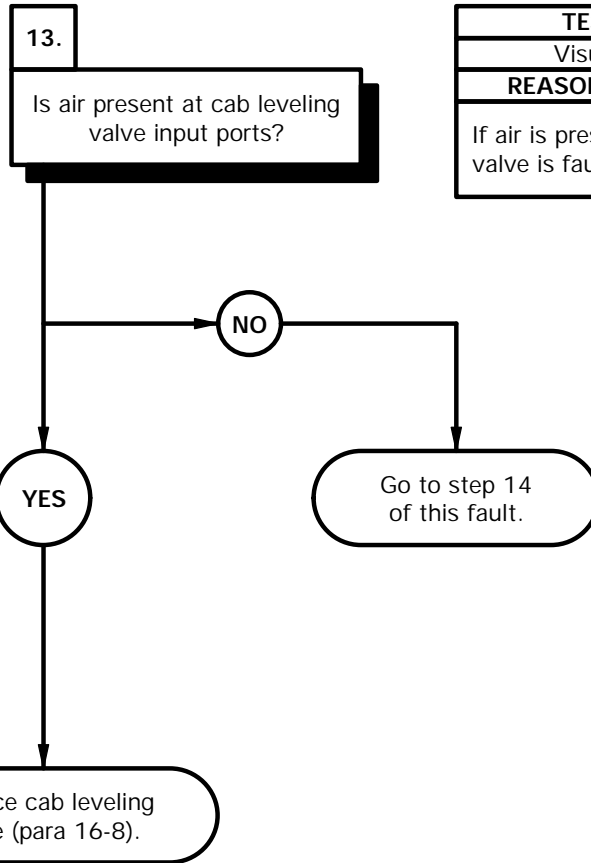

TEST OPTIONS
Visual Inspection
REASON FOR QUESTION
If air is present, cab leveling valve is faulty.



- (1) Start engine and allow air tanks to pressurize (TM 9-2320-366-10-1).
- (2) Shut down engine (TM 9-2320-366-10-1).
- (3) Raise cab (TM 9-2320-366-10-1).
- (4) Loosen air hoses 504 and 505 at cab leveling valve input ports.
- (5) Turn CAB knob to the left (TM 9-2320-366-10-1).
- (6) Check for presence of air at air hoses 504 and 505.
- (7) Tighten air hoses 504 and 505 at cab leveling valve input ports.
- (8) If air is not present, go to step 14 of this fault.
- (9) If air is present, replace cab leveling valve (para 16-8).

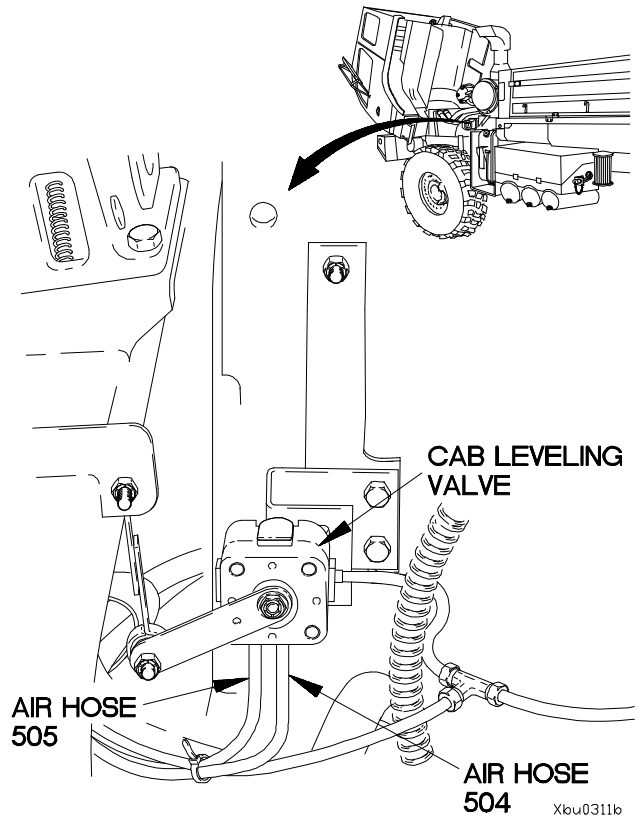

u3. CAB LEVELING AIR SPRINGS DO NOT OPERATE (CONT)

KNOWN INFO
CTIS operates. Air hoses free from kinks and leaks. Variable control check valve OK. Air hose 503 OK. Air hose 522 OK. Cab leveling valve tee fitting OK. Air hose 506 OK. Air/hydraulic manifold OK. Pressure protection valve OK. Air hose 501 OK. Cab leveling valve OK.
POSSIBLE PROBLEMS
Faulty air spring cylinder(s). Faulty air hose(s) 504 and/or 505.

14.
 Is air present at air spring cylinder output ports?

TEST OPTIONS
Visual Inspection
REASON FOR QUESTION
If air is present, air hose(s) 504 and/or 505 is faulty. If air is not present, air spring cylinder(s) is faulty.

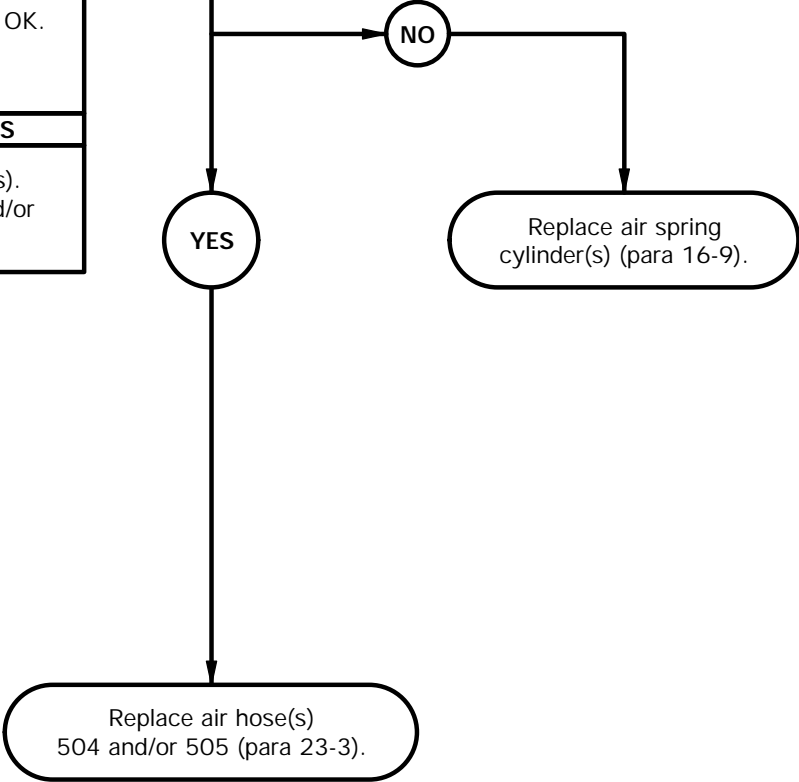

- (1) Loosen air hose 504 at RH air spring cylinder.
- (2) Turn CAB knob to the left (TM 9-2320-366-10-1).
- (3) Check for presence of air at RH air spring cylinder.
- (4) Tighten air hose 504 at RH air spring cylinder.
- (5) Repeat steps (1) through (4) on LH air spring cylinder and air hose 505.
- (6) Lower cab (TM 9-2320-366-10-1).
- (7) If air is not present, replace air spring cylinder(s) (para 16-9).
- (8) If air is present, replace air hose(s) 504 and/or 505 (para 23-3).

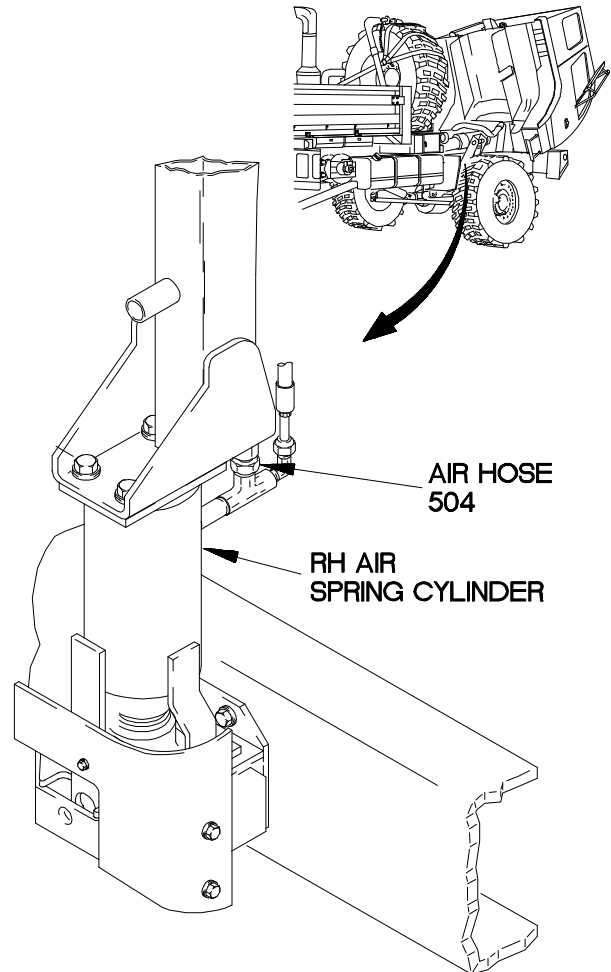

Xbu0312b

2-32. DUMP BODY HYDRAULIC SYSTEM TROUBLESHOOTING

This paragraph covers Dump Body Hydraulic System Troubleshooting. The Dump Body Hydraulic System Fault Index, Table 2-60, lists faults for the Dump Body Hydraulic System of the vehicle.

Table 2-60. Dump Body Hydraulic System Fault Index

Fault No.	Description	Page
v1.	Deleted.	

2-33. WRECKER HYDRAULIC SYSTEM TROUBLESHOOTING

This paragraph covers Wrecker Hydraulic System Troubleshooting. The Wrecker Hydraulic System Fault Index, Table 2-61, lists faults for the Wrecker Hydraulic System of the vehicle.

Table 2-61. Wrecker Hydraulic System Fault Index

Fault No.	Description	Page
w1.	M1089 Material Handling Crane (MHC) Does Not Operate	2-2244
w2.	M1089 Stifflegs/Left 30K Winch/15K SRW Do Not Operate	2-2246
w3.	M1089 Stiffleg(s) Does Not Operate or Operates Slowly	2-2248
w4.	M1089 Left 30K Winch Does Not Operate	2-2254
w5.	M1089 Stinger/Telescopic Lift Cylinders/Fold Cylinder/Right 30K Winch Do Not Operate	2-2256
w6.	M1089 Stinger Does Not Operate	2-2258
w7.	M1089 Underlift Telescopic Lift Cylinder(s) Does Not Operate	2-2260
w8.	M1089 Fold Cylinder Does Not Operate	2-2262
w9.	M1089 Right 30K Winch Does Not Operate	2-2264
w10.	M1089 Material Handling Crane (MHC) Hand Pump Does Not Work	2-2266
w11.	No Service or External Hydraulic Power From M1089	2-2268

w1. M1089 MATERIAL HANDLING CRANE (MHC) DOES NOT OPERATE	
INITIAL SETUP	
Equipment Conditions Engine shut down (TM 9-2320-366-10-1).	Tools and Special Tools Tool Kit, Genl Mech (Item 46, Appendix C)

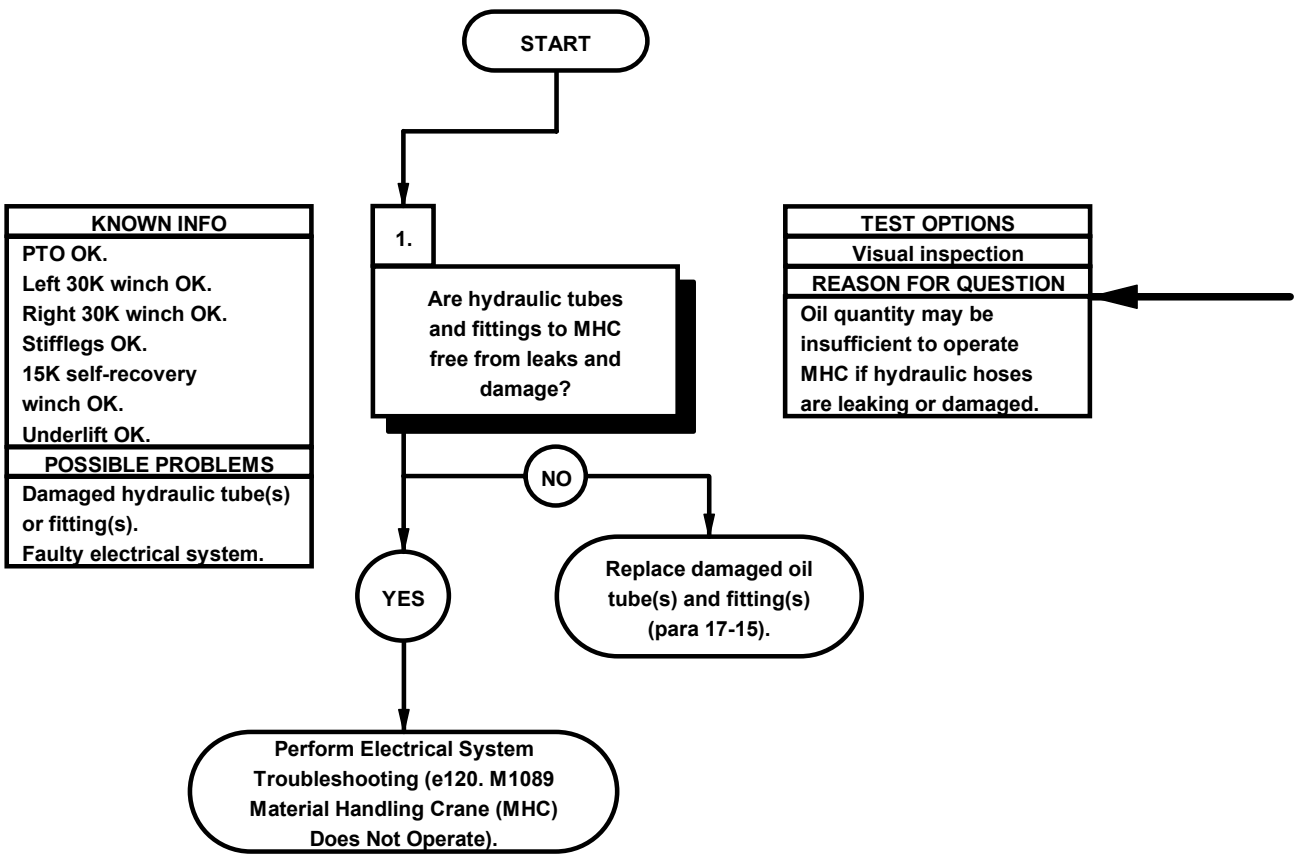

- (1) Check hydraulic tube and fittings between pump and check valve for leaks and damage.
- (2) Check hydraulic tube and fittings between check valve and port P of MHC for leaks and damage.
- (3) Check for proper hydraulic fluid level at reservoir (TM 9-2320-366-10-1).
- (4) If hydraulic tube(s) or fitting(s) is not free from leaks or damage, replace tube(s) or fitting(s) (para 17-15).
- (5) If hydraulic tubes and fitting are free from leaks and damage, perform Electrical System Troubleshooting (e120. M1089 Material Handling Crane (MHC) Does Not Operate).

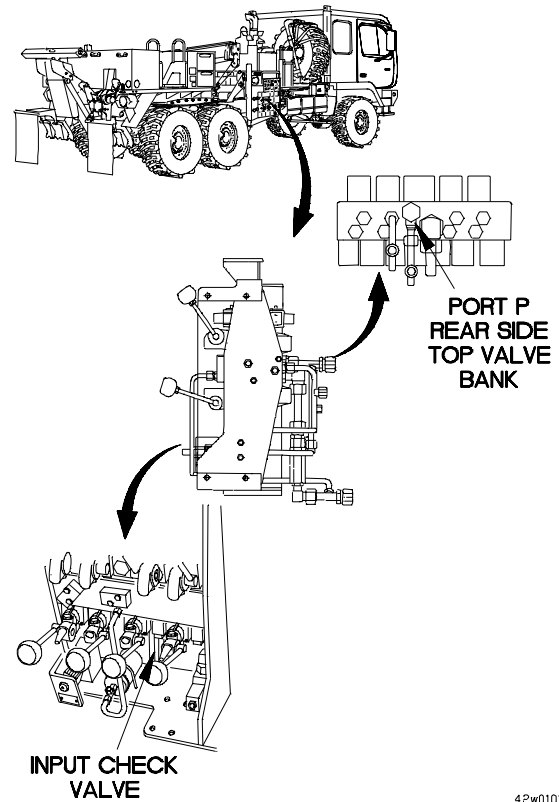

42w0101a

w2. M1089 STIFFLEGS/LEFT 30K WINCH/15K SELF-RECOVERY WINCH	
DO NOT OPERATE	
INITIAL SETUP	
Equipment Conditions Engine shut down (TM 9-2320-366-10-1).	Tools and Special Tools Tool Kit, Genl Mech (Item 46, Appendix C) STE/ICE-R (Item 41, Appendix C) Pan, Drain (Item 24, Appendix C) Goggles, Industrial (Item 15, Appendix C) Wrench, Torque, 0-175 lb-ft (Item 58, Appendix C) Transducer, STE/ICE-R (Item 1, Appendix J)
Personnel Required (2)	References TM 9-4910-571-12&P
Materials/Parts Rag, Wiping (Item 50, Appendix D) Cap and Plug Set (Item 14, Appendix D)	

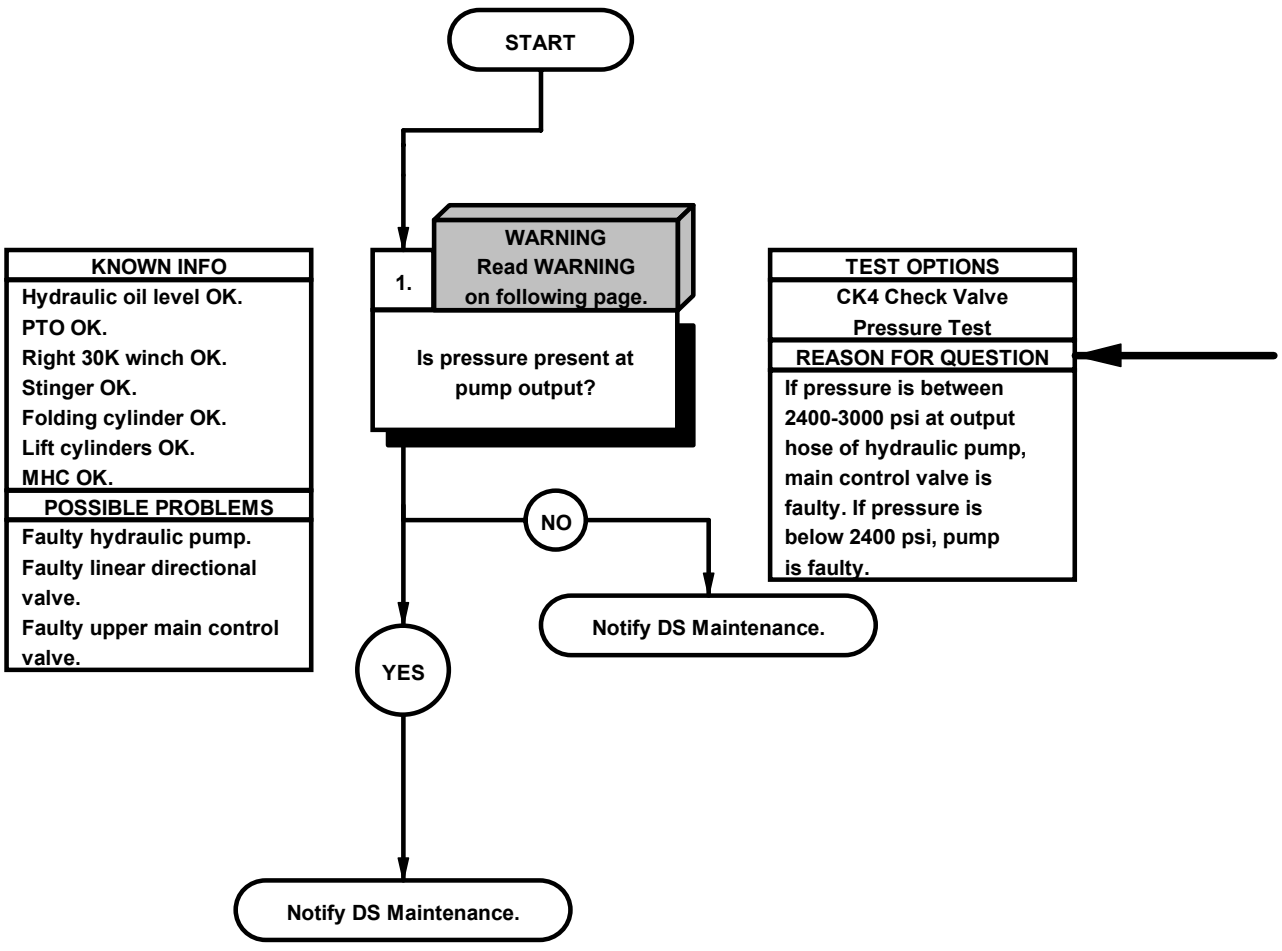

WARNING

- Drop hydraulic pressure to zero before disconnecting any hydraulic hoses, tubes and fittings. Failure to comply may result in injury to personnel.
- Wear approved eye protection when performing pressure checks. Failure to comply may result in oil getting into eyes. If oil contacts eyes, seek medical attention immediately.
- Fuel and oil are slippery and can cause falls. Wipe up spilled fuel or oil with rags. Failure to comply may result in injury to personnel.

NOTE

Adapter and tee kit used in this STE/ICE test, includes:

- (a) 3/4" swivel nut run tee.
- (b) 1/2" internal pipe, 3/4" 37 degree flare swivel adapter.

PRESSURE TEST

- (1) Place drain pan under vehicle.
- (2) Disconnect hydraulic pressure hose from lower main pressure tube.
- (3) Connect STE/ICE-R, with adapter and tee, between hydraulic pressure hose and tube.
- (4) Start engine (TM 9-2320-366-10-1).
- (5) Position PTO switch to on (TM 9-2320-366-10-1).
- (6) Perform STE/ICE-R test #51 (TM 9-4910-571-12&P) and note pressure reading is between 2400-3000 psi (16,548-20,685 kPa).
- (7) If pressure noted in step (6) is below 2400 psi (16,548 kPa), notify DS Maintenance.
- (8) If pressure noted in step (6) is between 2400-3000 kPa notify DS Maintenance.
- (9) Position PTO switch to off (TM 9-2320-366-10-1).
- (10) Shut down engine (TM 9-2320-366-10-1).
- (11) Disconnect STE/ICE-R, tee, and adapter from pressure line.
- (12) Connect hydraulic pressure hose to lower main pressure tube.
- (13) Tighten hydraulic hose to 36-39 lb-ft (49-53 N·m).

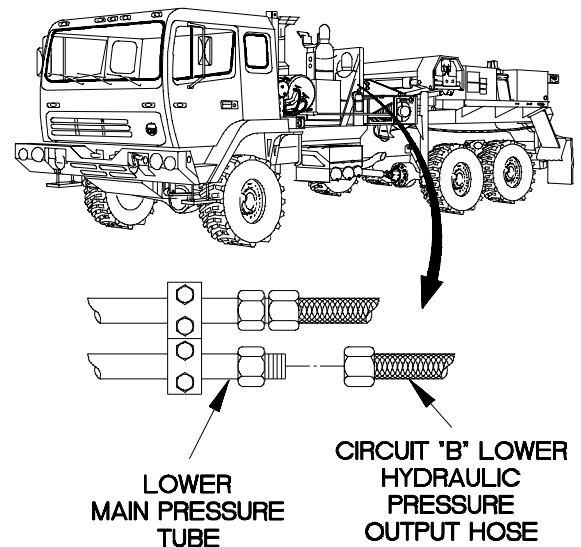

42w0201a

w3. M1089 STIFFLEG(S) DOES NOT OPERATE OR OPERATES SLOWLY	
INITIAL SETUP	
Equipment Conditions Engine shut down (TM 9-2320-366-10-1).	Tools and Special Tools Tool Kit, Genl Mech (Item 46, Appendix C) STE-ICE-R (Item 41, Appendix C) Pan, Drain (Item 24, Appendix C) Trestle, Motor Vehicle Maintenance (Item 47, Appendix C) Goggles, Industrial (Item 15, Appendix C) Transducer, STE/ICE-R (Item 1, Appendix J)
Personnel Required (2)	References TM 9-4910-571-12&P
Materials/Parts Rag, Wiping (Item 50, Appendix D) Lockwasher (6) (Item 100, Appendix G) Cap and Plug Set (Item 14, Appendix D)	

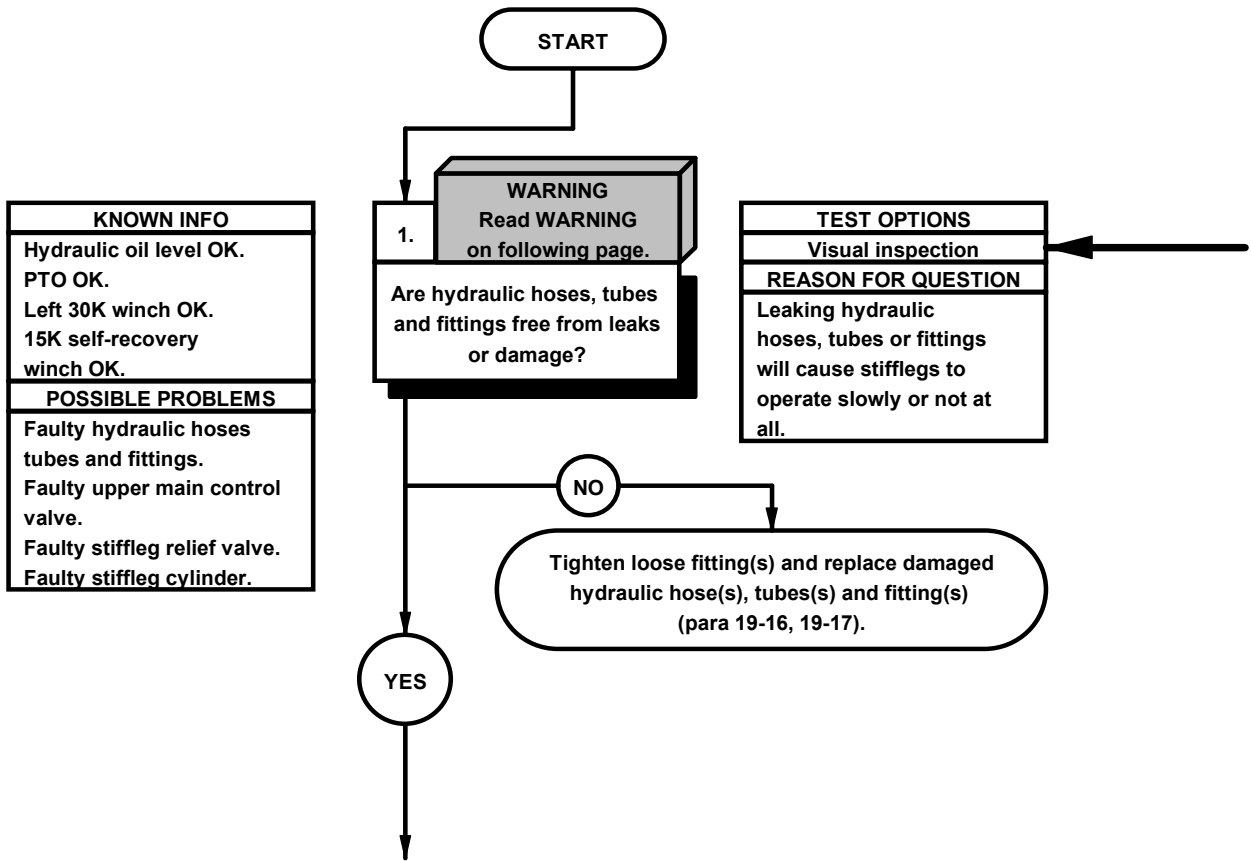

WARNING

- Drop hydraulic pressure to zero before disconnecting any hydraulic hoses, tubes, and fittings. Failure to comply may result in injury to personnel.
- Wear approved eye protection when performing pressure checks. Failure to comply may result in oil getting into eyes. If oil contacts eyes, seek medical attention immediately.
- Fuel and oil are slippery and can cause falls. Wipe up spilled fuel or oil with rags. Failure to comply may result in injury to personnel.

- (1) Place drain pan under vehicle.
- (2) Remove four screws, lockwashers, and washers from middle control panel cover. Discard lockwashers.
- (3) Remove two screws, washers, lockwashers, nuts and middle control panel cover from control panel. Discard lockwashers.
- (4) Check hydraulic hoses, tubes and fittings for leakage and damage from upper main control valve to stiffleg cylinders.
- (5) Position middle control panel cover on control panel with two screws, washers, lockwashers and nuts.
- (6) Install four washers, lockwashers and screws in middle control panel cover.

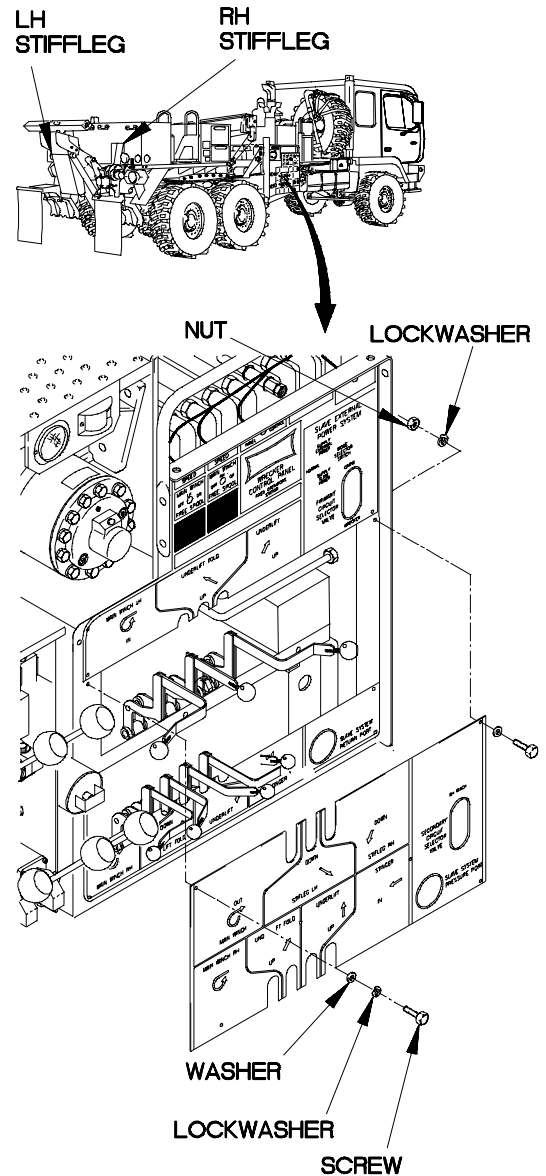

42w0301a

w3. M1089 STIFFLEG(S) DOES NOT OPERATE OR OPERATES SLOWLY (CONT)

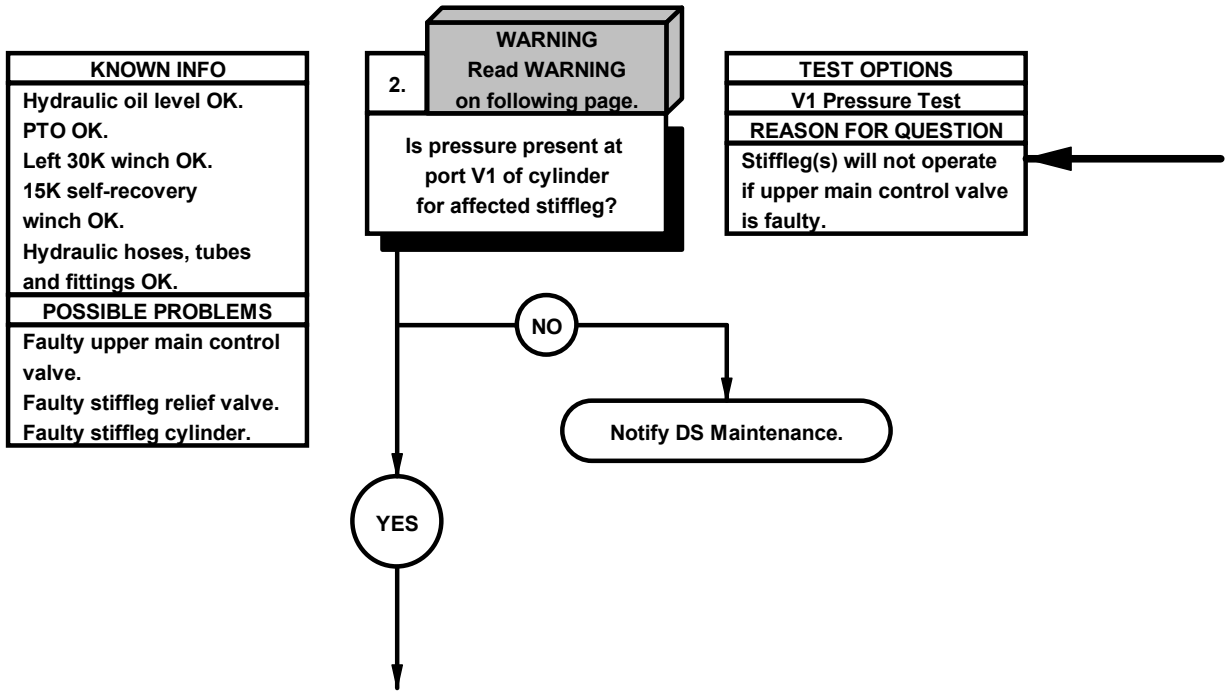

WARNING

- Wear approved eye protection when performing pressure checks. Failure to comply may result in oil getting into eyes. If oil contacts eyes, seek medical attention immediately.
- Fuel and oil are slippery and can cause falls. Wipe up spilled fuel or oil with rags. Failure to comply may result in injury to personnel.

V1 PRESSURE TEST

- (1) If stiffleg has failed in an off-the-ground position, place trestle under foot of stiffleg before doing tests.
- (2) Open box lid over affected stiffleg and slide off cylinder cover.
- (3) Disconnect UP pressure hose at V1 port of affected stiffleg cylinder.
- (4) Cap V1 fitting on top of cylinder.
- (5) Connect STE/ICE-R transducer and adapter onto end of disconnected UP pressure hose.
- (6) Start engine (TM 9-2320-366-10-1).
- (7) Position PTO switch to on (TM 9-2320-366-10-1).
- (8) Perform STE/ICE-R test # 51. (TM 9-4910-571-12&P).
- (9) Momentarily position stiffleg lever for affected stiffleg to UP position, release lever.
- (10) Observe pressure reading. If pressure is below 3000 psi (20,685 kPa), notify DS Maintenance.
- (11) Position PTO switch to off (TM 9-2320-366-10-1).
- (12) Shut down engine (TM 9-2320-366-10-1).
- (13) Disconnect STE/ICE-R from UP pressure hose.
- (14) Remove cap from V1 fitting on top of cylinder.
- (15) Connect UP pressure hose to V1 port of cylinder.
- (16) Close box lid cover over affected stiff leg cylinder.
- (17) Remove trestle if required.

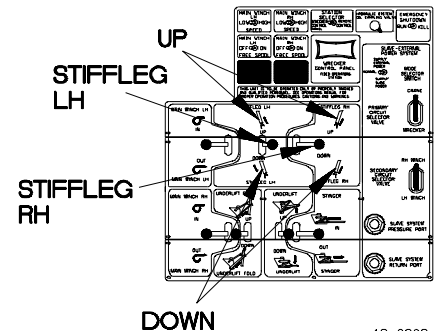
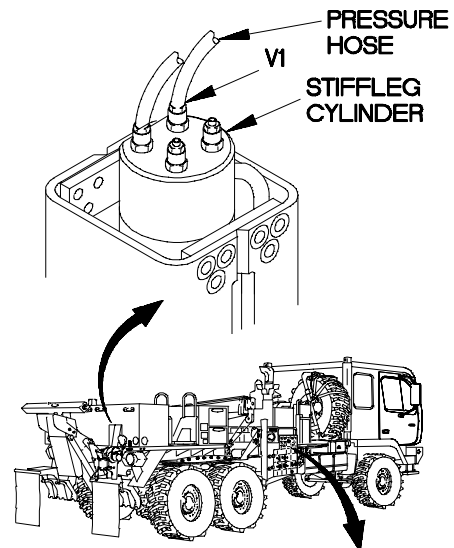

42w0302a

w3. M1089 STIFFLEG(S) DOES NOT OPERATE OR OPERATES SLOWLY (CONT)

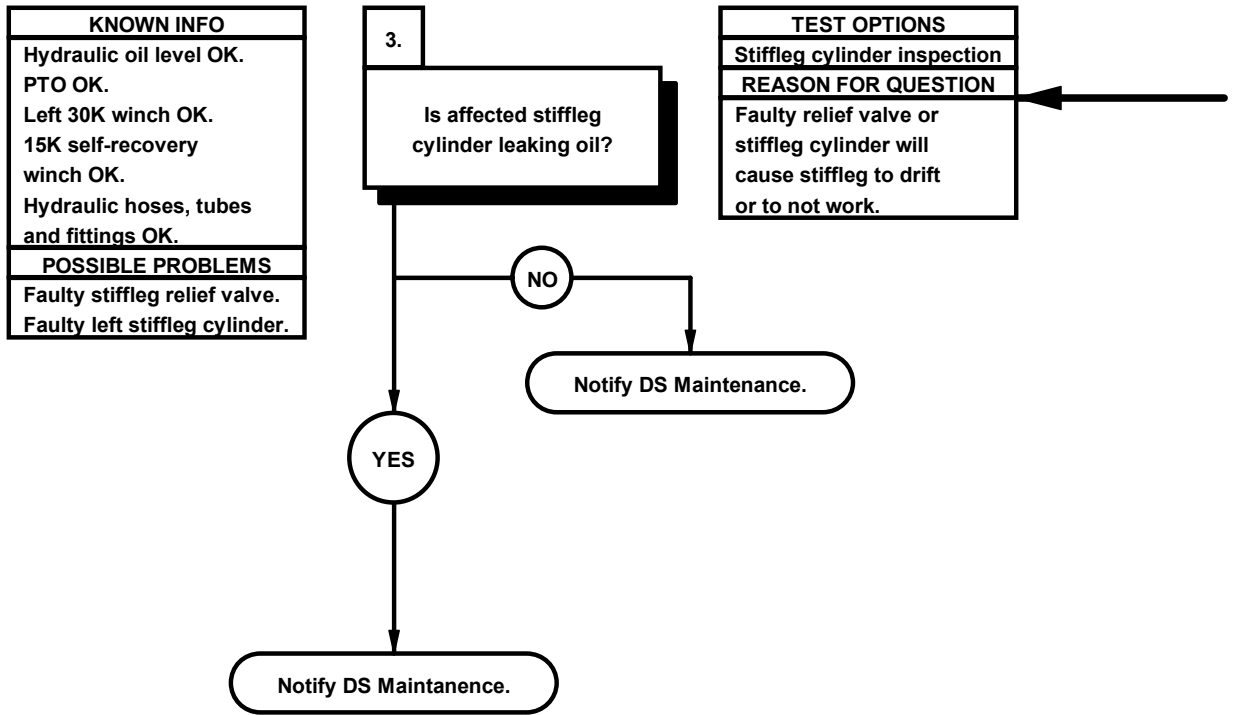

STIFFLEG CYLINDER INSPECTION

- (1) Start engine (TM 9-2320-366-10-1).
- (2) Position PTO switch to on (TM 9-2320-366-10-1).
- (3) If stiffleg will operate, lower and raise left stiffleg two or more times (TM 9-2320-366-10-1) and observe stiffleg for leaks.
- (4) If leaks are observed in step (3) notify DS Maintenance.
- (5) If cylinder is dry, notify DS Maintenance.
- (6) Position PTO switch to off (TM 9-2320-366-10-1).
- (7) Shut down engine (TM 9-2320-366-10-1).
- (8) Slide cover over cylinder into closed position.
- (9) Remove drain pan from under vehicle.

w4. M1089 LH 30K WINCH DOES NOT OPERATE

INITIAL SETUP

Equipment Conditions

Engine shut down (TM 9-2320-366-10-1).

Materials/Parts

Rag, Wiping (Item 50, Appendix D)

Tools and Special Tools

Tool Kit, Genl Mech (Item 46, Appendix C)

Pan, Drain (Item 24, Appendix C)

Goggles, Industrial (Item 15, Appendix C)

NOTE

Perform Electrical System Troubleshooting task e138A. M1089 LH or RH 30K Winch Does Not Pay-In and Wrecker Air System Troubleshooting task aa1. M1089 LH or RH 30K Winch Does Not Pay-In prior to beginning this task.

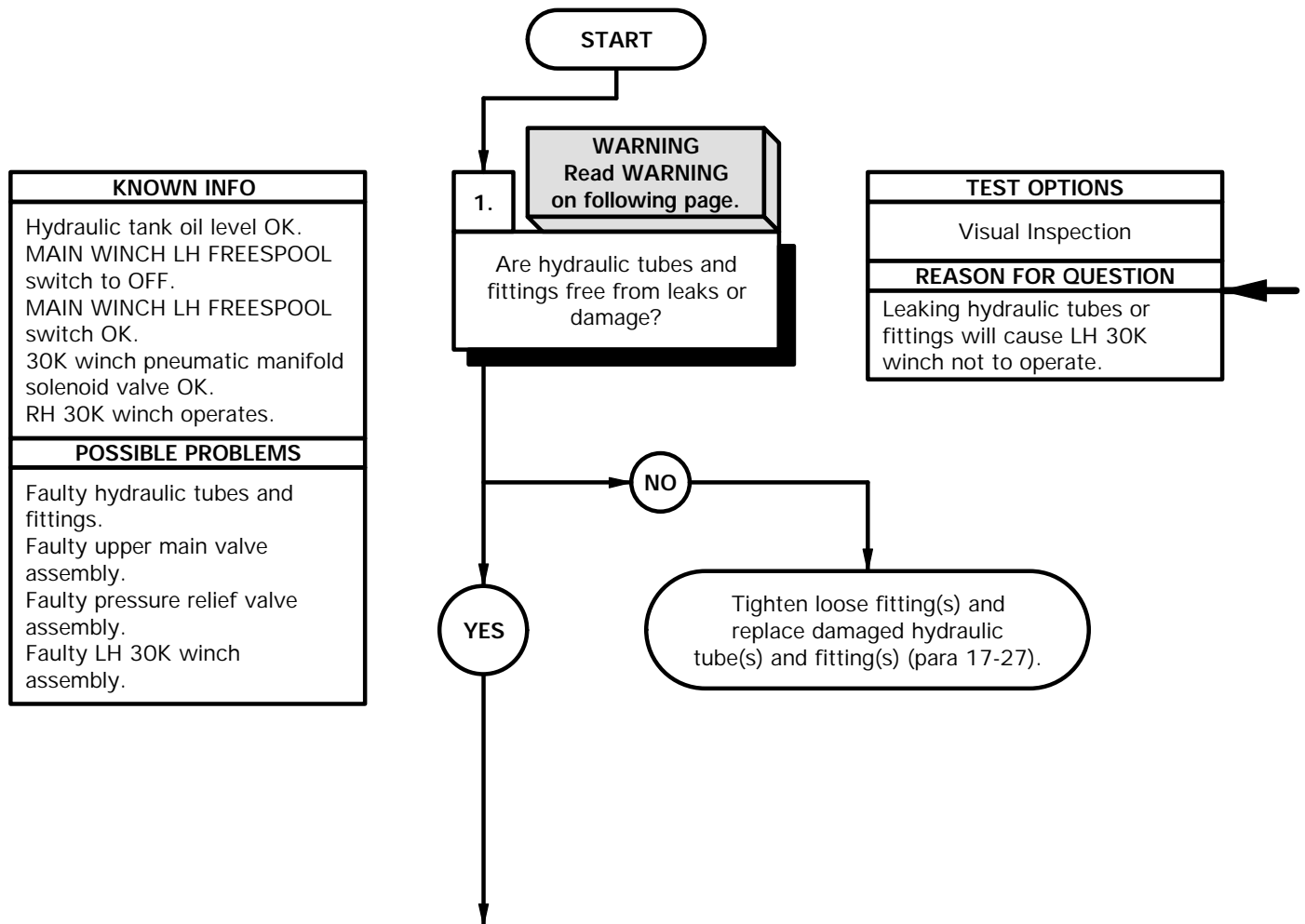

WARNING

Drop hydraulic pressure to zero before disconnecting any hydraulic hoses, tubes, and fittings. Failure to comply may result in injury to personnel.

Wear approved eye protection when performing pressure checks. Failure to comply may result in oil getting into eyes. If oil contacts eyes, seek medical attention immediately.

Fuel and oil are slippery and can cause falls. Wipe up spilled fuel or oil with rags. Failure to comply may result in injury to personnel.

- (1) Check hydraulic tubes and fittings for leakage and damage.
- (2) If hydraulic tubes and fittings are leaking or damaged, tighten loose fitting(s) and replace damaged hydraulic tube(s) and fitting(s).

w4. M1089 LH 30K WINCH DOES NOT OPERATE (CONT)

KNOWN INFO
Hydraulic tank oil level OK. MAIN WINCH LH FREESPOOL switch to OFF. MAIN WINCH LH FREESPOOL switch OK. 30K winch pneumatic manifold solenoid valve OK. RH 30K winch operates. Hydraulic tubes and fittings OK.
POSSIBLE PROBLEMS
Faulty upper main valve assembly. Faulty pressure relief valve assembly. Faulty LH 30K winch assembly.

2.
Do LH and RH stifflegs operate?

TEST OPTIONS
Operational Test
REASON FOR QUESTION
This question eliminates possible problems and determines where to continue troubleshooting.

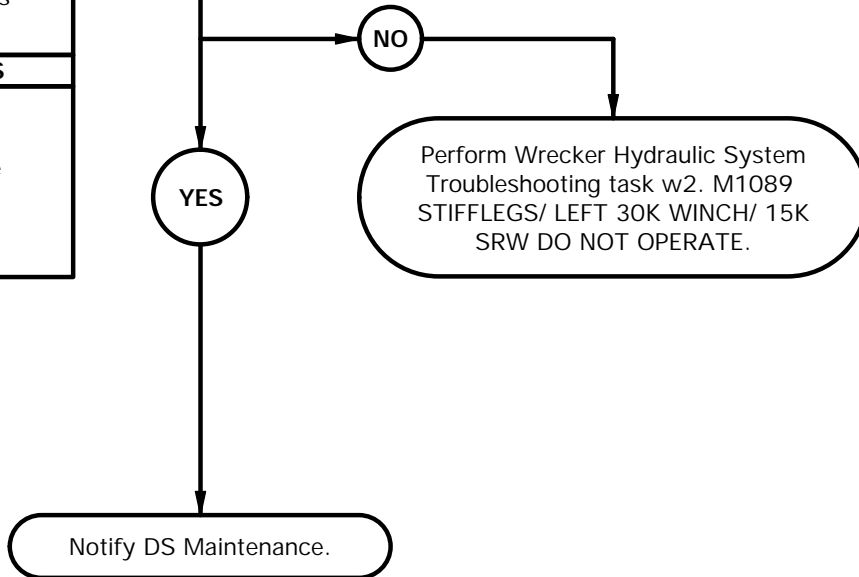

OPERATIONAL TEST

- (1) Attempt to operate LH and RH stifflegs (TM 9-2320-366-10-2).
- (2) If LH and RH stifflegs do not operate, perform Wrecker Hydraulic System Troubleshooting task w2. M1089 STIFFLEGS/ LEFT 30K WINCH/ 15K SRW DO NOT OPERATE.
- (3) If LH and RH stifflegs does operate, notify DS Maintenance.

w5. M1089 STINGER/TELESCOPIC LIFT CYLINDERS/FOLDING CYLINDERS/RIGHT 30K WINCH DO NOT OPERATE	
INITIAL SETUP	
Equipment Conditions Engine shut down (TM 9-2320-366-10-1).	Tools and Special Tools Tool Kit, Gen Mech (Item 46, Appendix C) STE/ICE-R (Item 41, Appendix C) Pan, Drain (Item 24, Appendix C) Goggles, Industrial (Item 15, Appendix C) Wrench, Torque, 0-175 lb-ft (Item 58, Appendix C) Transducer, STE/ICE-R (Item 1, Appendix J)
Personnel Required (2)	References TM 9-4910-571-12&P
Material/Parts Rag, Wiping (Item 50, Appendix D)	

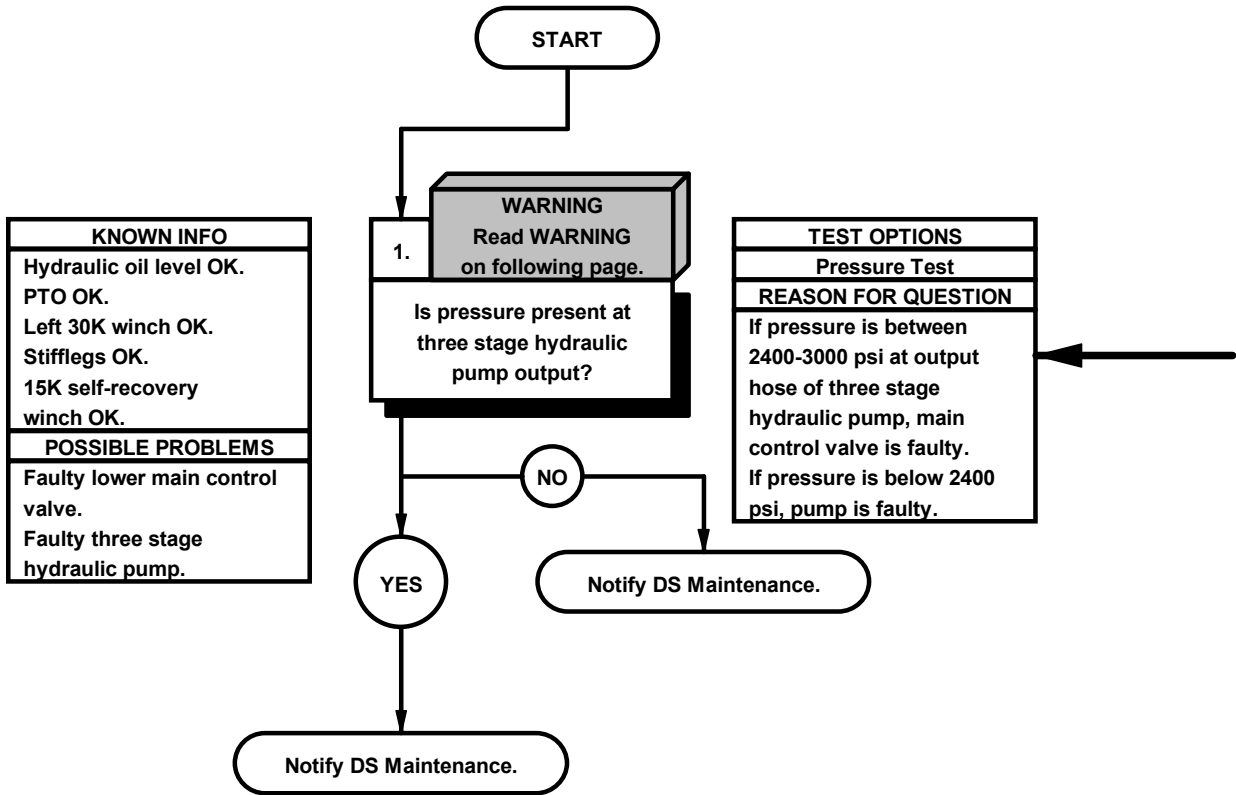

WARNING

- Drop hydraulic pressure to zero before disconnecting any hydraulic hoses, tubes, and fittings. Failure to comply may result in injury to personnel.
- Wear approved eye protection when performing pressure checks. Failure to comply may result in oil getting into eyes. If oil contacts eyes, seek medical attention immediately.
- Fuel and oil are slippery and can cause falls. Wipe up spilled fuel or oil with rags. Failure to comply may result in injury to personnel.

NOTE

Tee and adapter used in STE/ICE test are:

- (a) 3/4" swivel nut run tee.
- (b) Internal pipe 1/2" F/ 37 degree flair 3/4"F swivel adapter.

PRESSURE TEST

- (1) Place drain pan under vehicle.
- (2) Disconnect hydraulic pressure hose from upper main pressure tube.
- (3) Connect STE/ICE-R, with adapter and tee between hydraulic pressure hose and tube.
- (4) Start engine (TM 9-2320-366-10-1).
- (5) Position PTO switch to on (TM 9-2320-366-10-1).
- (6) Perform STE/ICE-R test #51 (TM 9-4910-571-12&P) and note pressure reading is between 2400-3000 psi (16,548-20,685 kPa).
- (7) If pressure noted in step (6) is below 2400 psi (16,548 kPa), notify DS Maintenance.
- (8) If pressure noted in step (6) is between 2400-3000 psi (16,548-20,685 kPa), notify DS Maintenance.
- (9) Position PTO switch to off (TM 9-2320-366-10-1).
- (10) Shut down engine (TM 9-2320-366-10-1).
- (11) Disconnect STE/ICE-R test equipment, adapter and tee from hydraulic pressure hose.
- (12) Connect hydraulic pressure hose to upper main pressure tube valve.
- (13) Tighten hydraulic tube fitting to 36-39 lb-ft (49-53 N-m).
- (14) Remove drain pan from under vehicle.

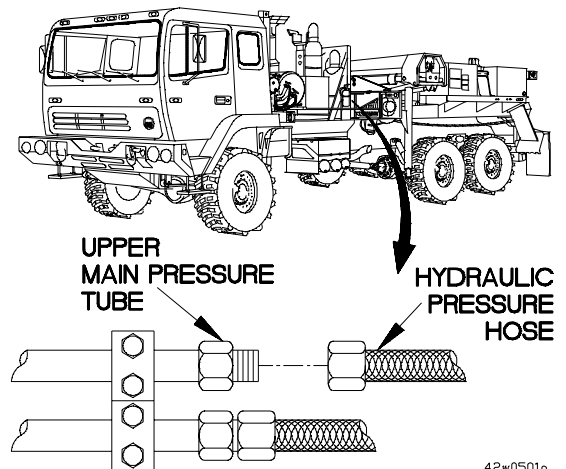

42w0501a

w6. M1089 STINGER DOES NOT OPERATE	
INITIAL SETUP	
Equipment Conditions Engine shut down (TM 9-2320-366-10-1).	Tools and Special Tools Tool Kit, Gen Mech (Item 46, Appendix C)

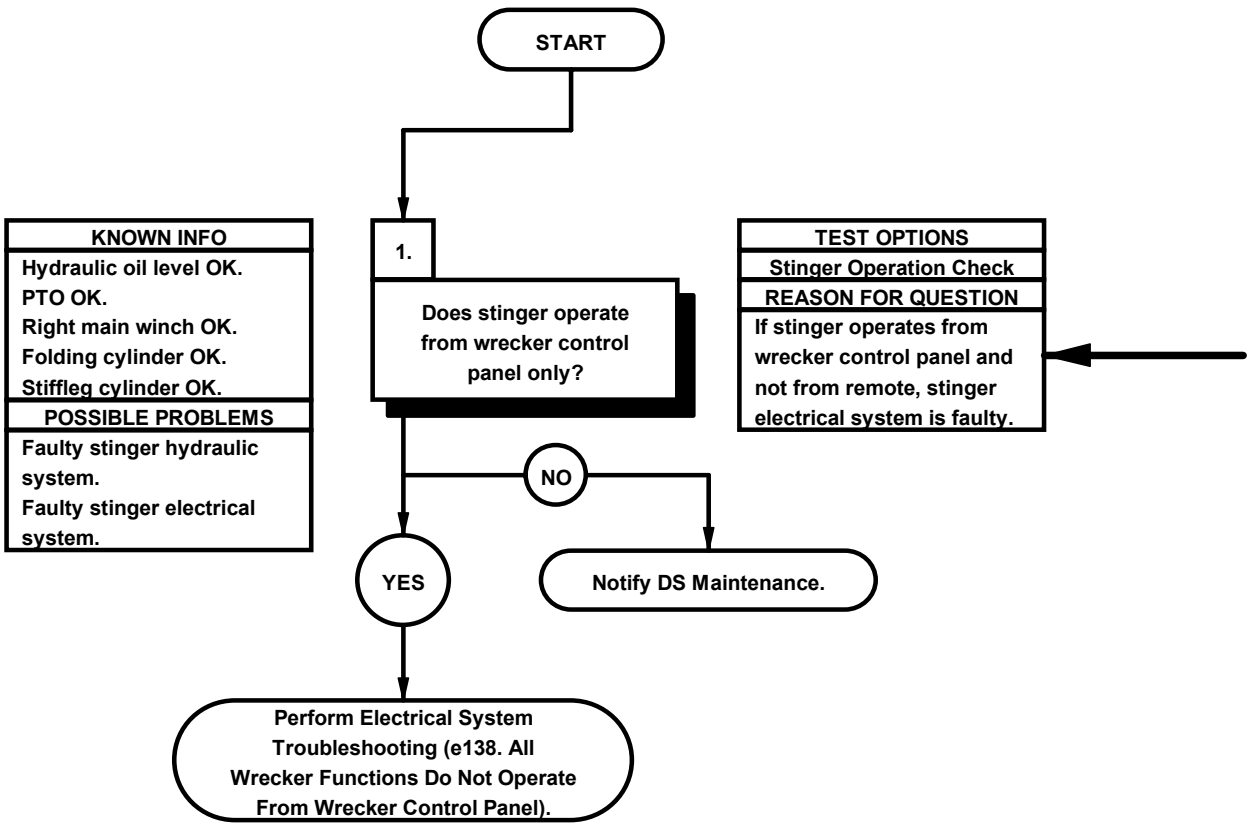

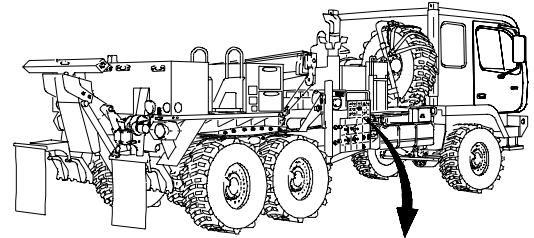

- STINGER OPERATIONAL CHECK**
- (1) Connect remote control unit to RH remote control hook-up (J2) at rear of vehicle.
 - (2) Start engine (TM 9-2320-366-10-1).
 - (3) Position PTO switch to on (TM 9-2320-366-10-1).
 - (4) Position STATION SELECTOR switch to REMOTE CONTROL.
 - (5) Check if stinger operates at remote control (TM 9-2320-366-10-1).
 - (6) Position STATION SELECTOR switch to WRECKER CONTROL panel.
 - (7) Check if stinger operates IN or OUT from wrecker control panel (TM 9-2320-366-10-1).
 - (8) If stinger does not operate from remote or wrecker control panel, notify DS Maintenance.
 - (9) If stinger operates from wrecker control panel but not remote, perform Electrical System Troubleshooting (e138. All Wrecker Functions Do Not Operate From Wrecker Control Panel).
 - (10) Position PTO switch to off (TM 9-2320-366-10-1).
 - (11) Shut down engine (TM 9-2320-366-10-1).
 - (12) Remove and stow remote control unit and cable.

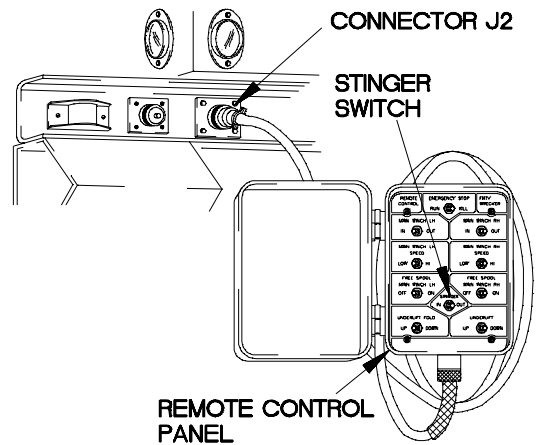
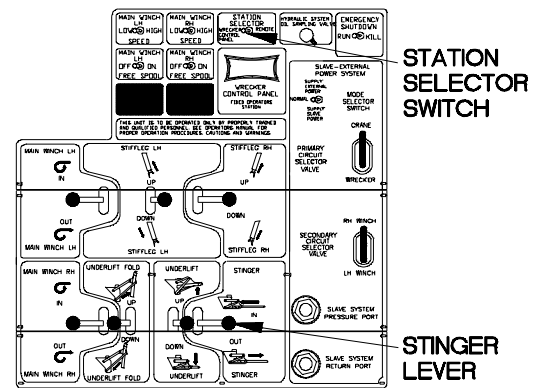

42w0601a

w7. M1089 UNDERLIFT TELESCOPIC LIFT CYLINDER(S) DOES NOT OPERATE	
INITIAL SETUP	
Equipment Conditions Engine shut down (TM 9-2320-366-10-1).	Tools and Special Tools Tool Kit, Gen Mech (Item 46, Appendix C)

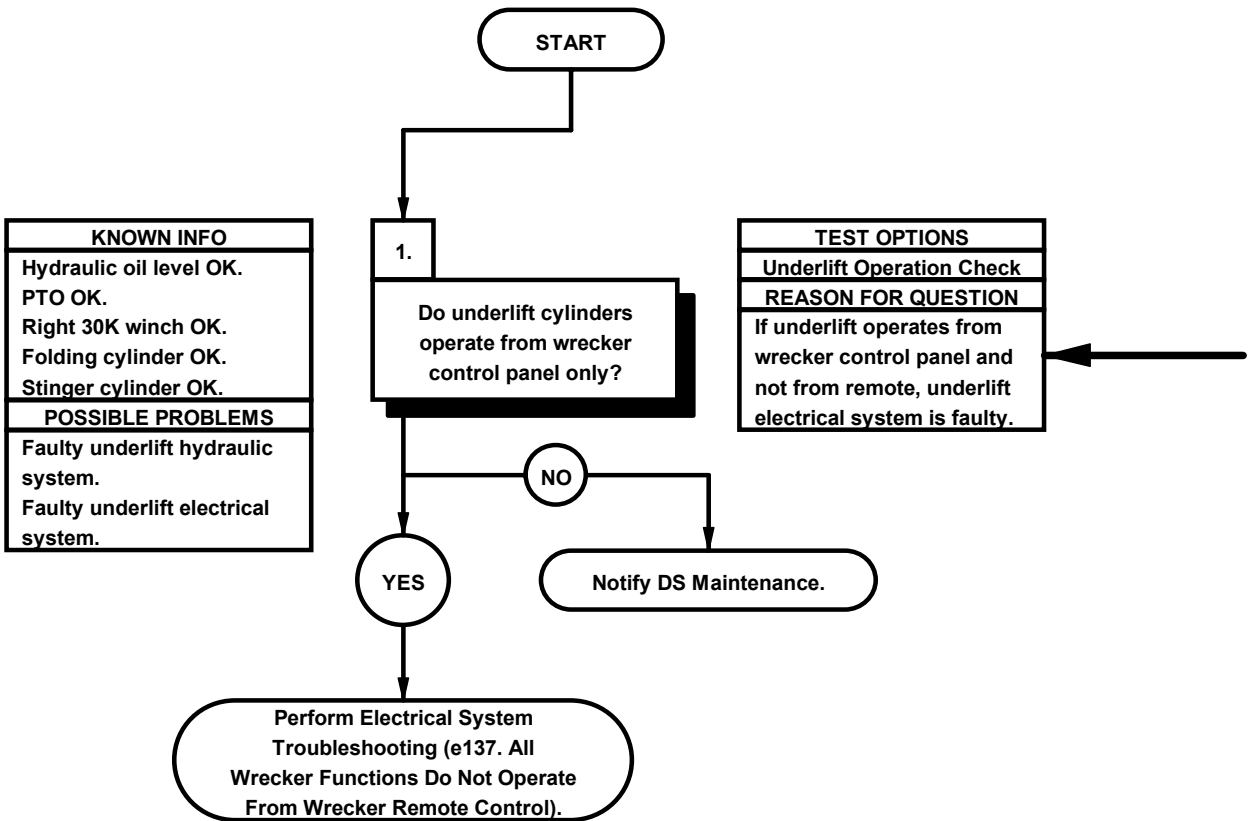

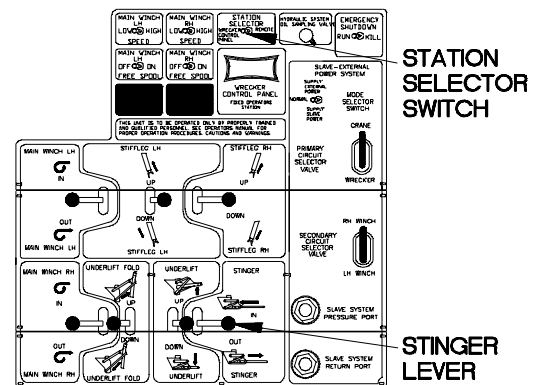
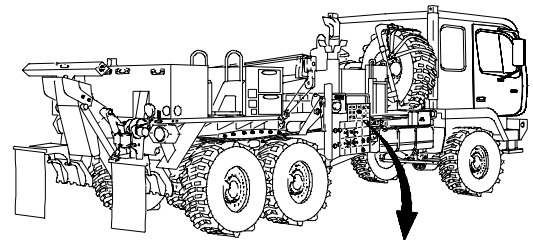

- UNDERLIFT OPERATIONAL CHECK**
- (1) Connect remote control unit to RH remote control hook-up (J2) at rear of vehicle.
 - (2) Start engine (TM 9-2320-366-10-1).
 - (3) Position PTO switch to on (TM 9-2320-366-10-1).
 - (4) Position STATION SELECTOR switch to REMOTE CONTROL.
 - (5) Check if underlift operates at remote control (TM 9-2320-366-10-1).
 - (6) Position STATION SELECTOR switch to WRECKER CONTROL panel.
 - (7) Check if underlift operates UP or DOWN from wrecker control panel (TM 9-2320-366-10-1).
 - (8) If underlift does not operate from remote or wrecker control panel, notify DS Maintenance.
 - (9) If underlift operates from wrecker control panel but not remote, perform Electrical System Troubleshooting (e137. All Wrecker Functions Do Not Operate From Wrecker Remote Control).
 - (10) Position PTO switch to off (TM 9-2320-366-10-1).
 - (11) Shut down engine (TM 9-2320-366-10-1).
 - (12) Remove and stow remote control.

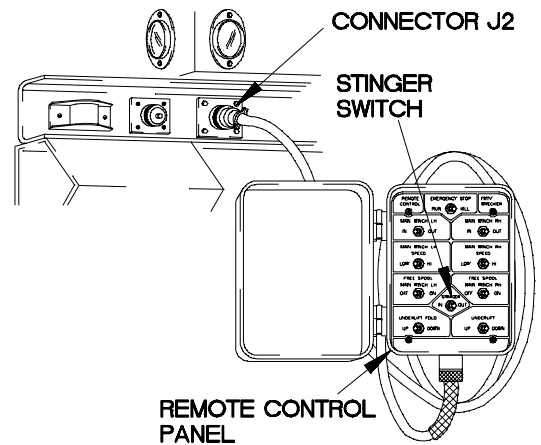

42W07011

w8. M1089 FOLDING CYLINDER DOES NOT OPERATE	
INITIAL SETUP	
Equipment Conditions Engine shut down (TM 9-2320-366-10-1).	Tools and Special Tools Tool Kit, Genl Mech (Item 46, Appendix C)

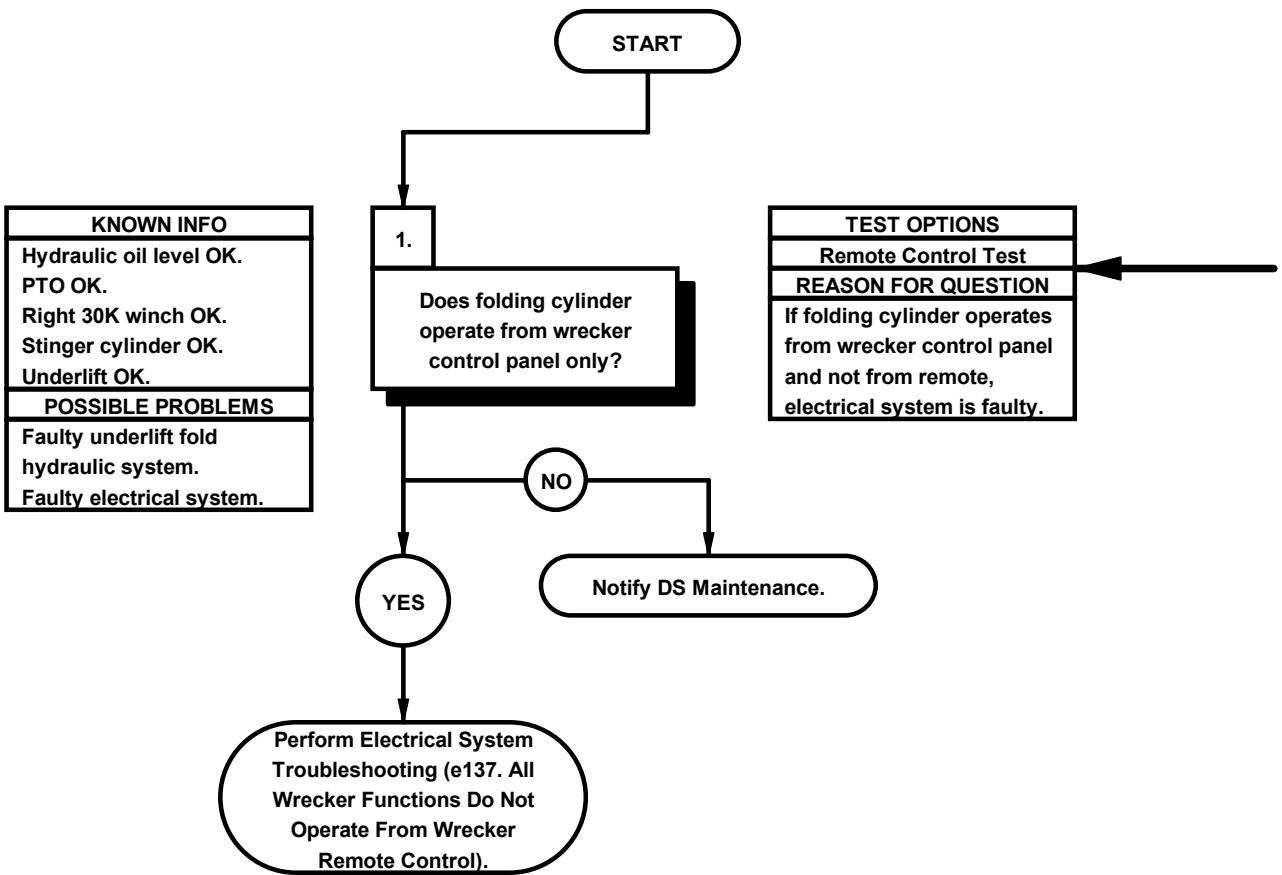

REMOTE CONTROL TEST

- (1) Connect remote control unit to RH remote control connector (J2) at rear of wrecker (TM 9-2320-366-10-1).
- (2) Start engine (TM 9-2320-366-10-1).
- (3) Position PTO switch to on (TM 9-2320-366-10-1).
- (4) Position STATION SELECTOR switch to REMOTE CONTROL (TM 9-2320-366-10-1).
- (5) Check if folding cylinder operates (UP or DOWN) at REMOTE CONTROL panel (TM 9-2320-366-10-1).
- (6) Position STATION SELECTOR switch to WRECKER CONTROL panel (TM 9-2320-366-10-1).
- (7) Check if folding cylinder operates (UP or DOWN) from wrecker control panel.
- (8) If folding cylinder does not operate from remote or wrecker control panels, notify DS Maintenance.
- (9) If folding cylinder operates from wrecker control panel but not from remote, perform Electrical System Troubleshooting (e137. All Wrecker Functions Do Not Operate From Wrecker Remote Control).
- (10) Position PTO switch to off (TM 9-2320-366-10-1).
- (11) Shut down engine (TM 9-2320-366-10-1).
- (12) Disconnect remote control unit and stow.

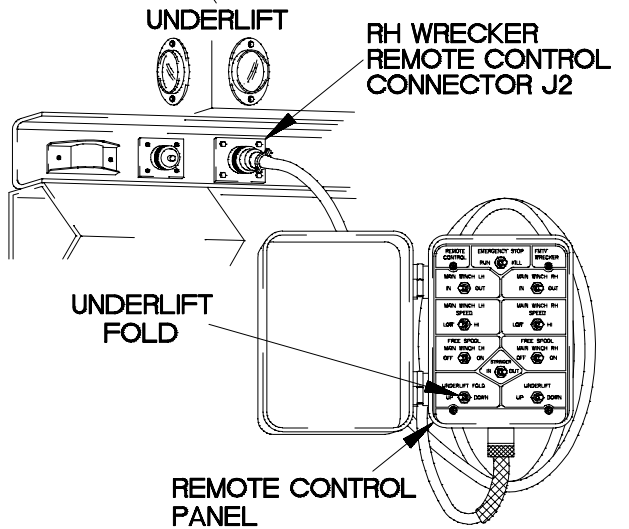
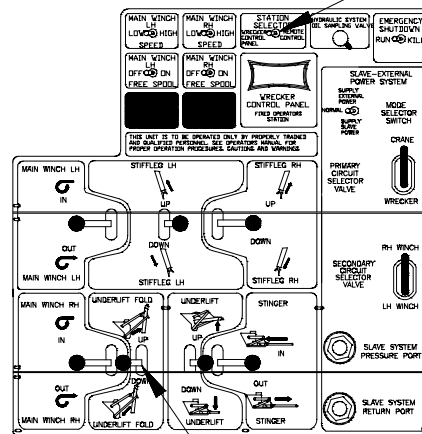
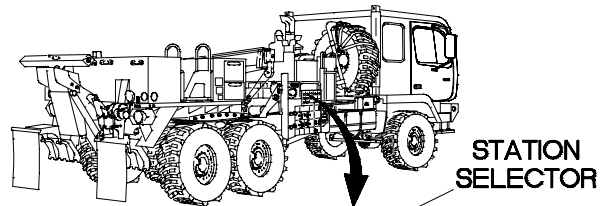

42W0801A

w9. M1089 RH 30K WINCH DOES NOT OPERATE

INITIAL SETUP

Equipment Conditions

Engine shut down (TM 9-2320-366-10-1).

Materials/Parts

Rag, Wiping (Item 50, Appendix D)

Tools and Special Tools

Tool Kit, Genl Mech (Item 46, Appendix C)

Pan, Drain (Item 24, Appendix C)

Goggles, Industrial (Item 15, Appendix C)

NOTE

Perform Electrical System Troubleshooting task e138A. M1089 LH or RH 30K Winch Does Not Operate and Wrecker Air System Troubleshooting task aa1. M1089 LH or RH 30K Winch Does Not Operate prior to beginning this task.

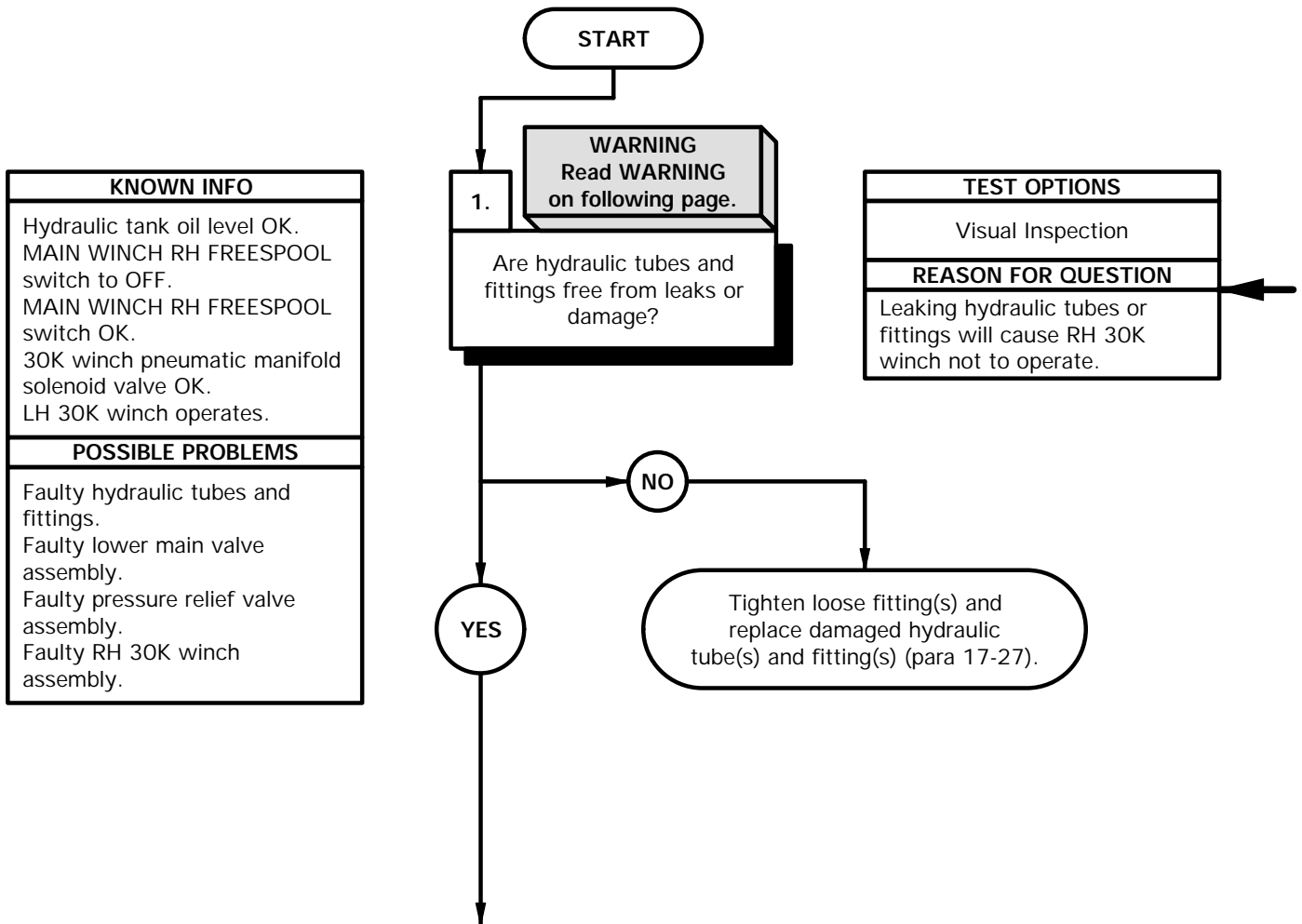

WARNING

Drop hydraulic pressure to zero before disconnecting any hydraulic hoses, tubes, and fittings. Failure to comply may result in injury to personnel.

Wear approved eye protection when performing pressure checks. Failure to comply may result in oil getting into eyes. If oil contacts eyes, seek medical attention immediately.

Fuel and oil are slippery and can cause falls. Wipe up spilled fuel or oil with rags. Failure to comply may result in injury to personnel.

- (1) Place drain pan under vehicle.
- (2) Check hydraulic tubes and fittings for leakage and damage.

w9. M1089 RH 30K WINCH DOES NOT OPERATE (CONT)

KNOWN INFO
Hydraulic tank oil level OK. MAIN WINCH RH FREESPOOL switch to OFF. MAIN WINCH RH FREESPOOL switch OK. 30K winch pneumatic manifold solenoid valve OK. LH 30K winch operates. Hydraulic tubes and fittings OK.
POSSIBLE PROBLEMS
Faulty lower main valve assembly. Faulty pressure relief valve assembly. Faulty RH 30K winch assembly.

2.
Does underlift fold cylinder operate?

TEST OPTIONS
Operational Test
REASON FOR QUESTION
This question eliminates possible problems and determines where to continue troubleshooting.

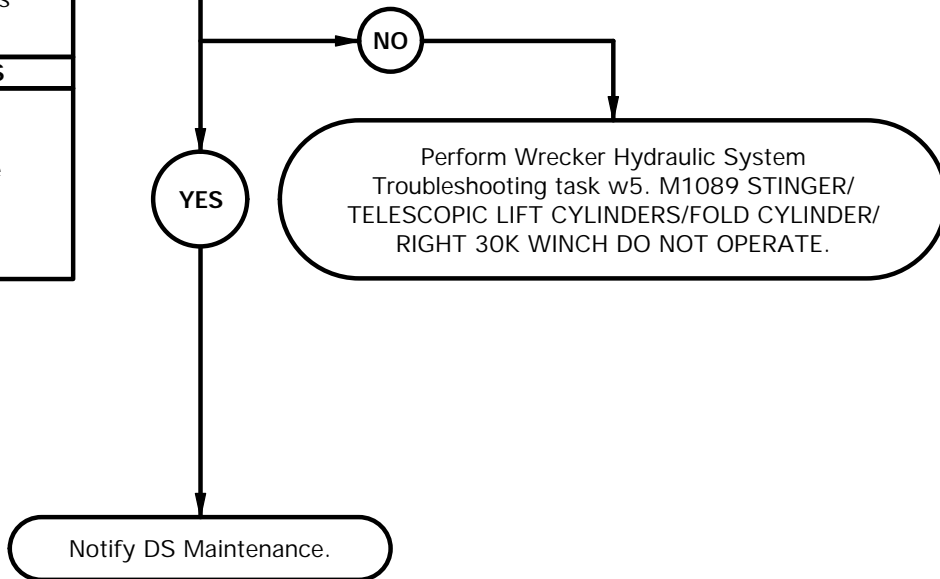

OPERATIONAL TEST

- (1) Attempt to operate underlift
(TM 9-2320-366-10-2).
- (2) If underlift does not operate, perform
Wrecker Hydraulic System Troubleshooting
task w5. M1089 STINGER/TELESCOPIC
LIFT CYLINDERS/FOLD CYLINDER/RIGHT
30K WINCH DO NOT OPERATE.
- (3) If underlift does operate, notify DS
Maintenance.

w10. M1089 MATERIAL HANDLING CRANE (MHC) HAND PUMP DOES NOT WORK	
INITIAL SETUP	
Equipment Conditions Engine shut down (TM 9-2320-366-10-1).	Tools and Special Tools Tool Kit, Genl Mech (Item 46, Appendix C) Pan, Drain (Item 24, Appendix C) Goggles, Industrial (Item 15, Appendix C)
	Materials/Parts Rag, Wiping (Item 50, Appendix D)

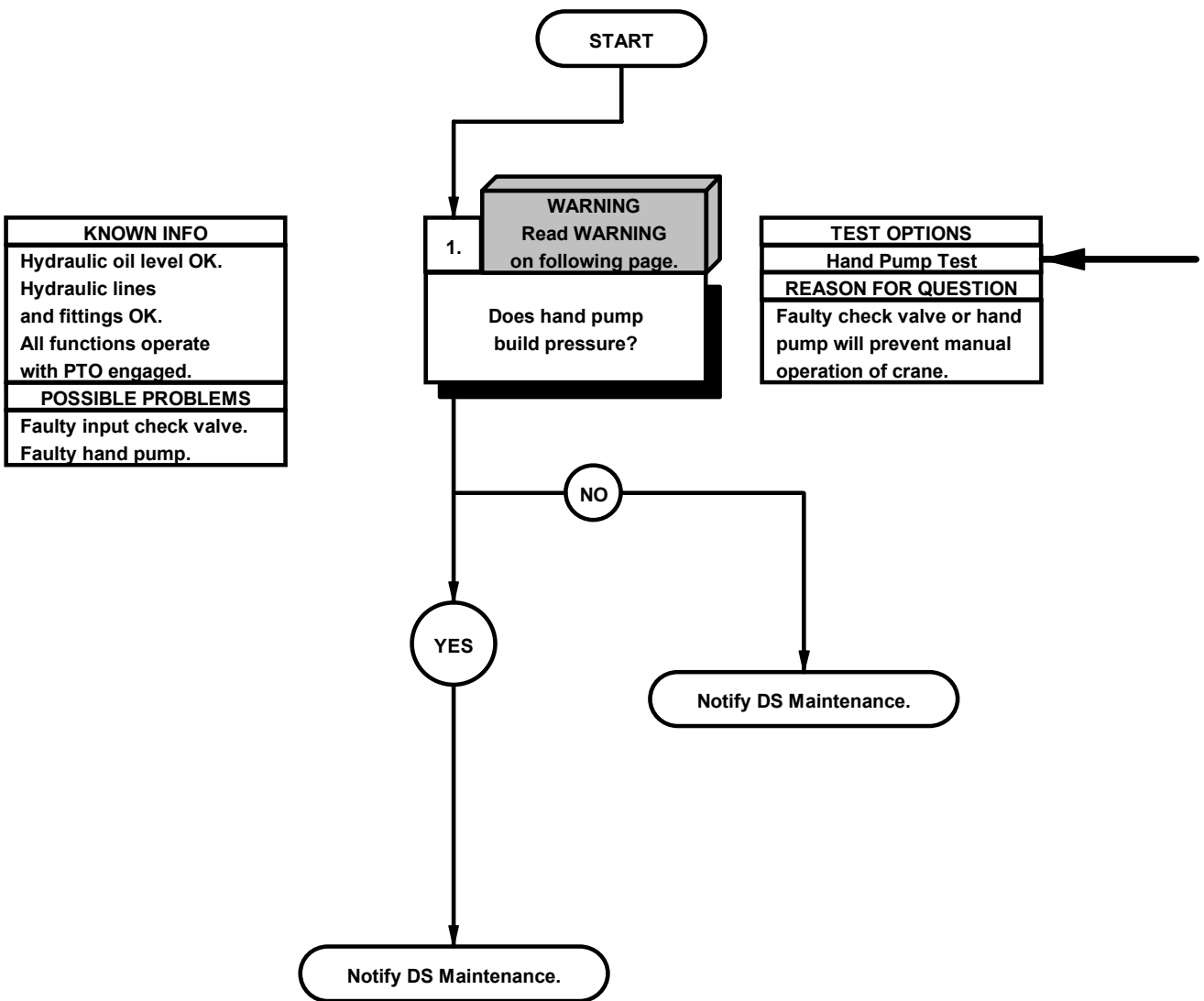

WARNING

- Drop hydraulic pressure to zero before disconnecting any hydraulic line. Failure to comply may result in injury to personnel.
- Wear approved eye protection when performing pressure checks. Failure to comply may result in oil getting into eyes. If oil contacts eyes, seek medical attention immediately.
- Fuel and oil are slippery and can cause falls. Wipe up spilled fuel or oil with rags. Failure to comply may result in injury to personnel.

HAND PUMP TEST

- (1) Disconnect hand pump delivery line from elbow at hand pump.
- (2) Place drain pan under port at pump to catch hydraulic fluid.
- (3) Pump hand pump (TM 9-2320-366-10-1).
- (4) Check if hydraulic fluid pumps out of port with each stroke.
- (5) If little or no hydraulic fluid pumps out, hand pump is faulty.
- (6) Connect delivery line to elbow at hand pump.
- (7) Remove drain pan.

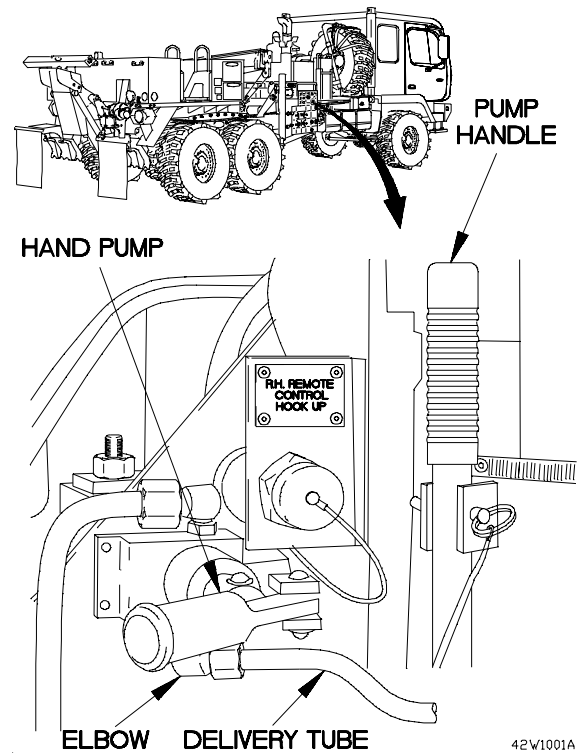

42W1001A

w11. NO SERVICE OR EXTERNAL HYDRAULIC POWER FROM M1089	
INITIAL SETUP	
Equipment Conditions Engine shut down (TM 9-2320-366-10-1).	Tools and Special Tools Tool Kit, Genl Mech (Item 46, Appendix C) Pan, Drain (Item 24, Appendix C) Goggles, Industrial (Item 15, Appendix C)
	Materials/Parts Rag, Wiping (Item 50, Appendix D) Lockwasher (6) (Item 100, Appendix G)

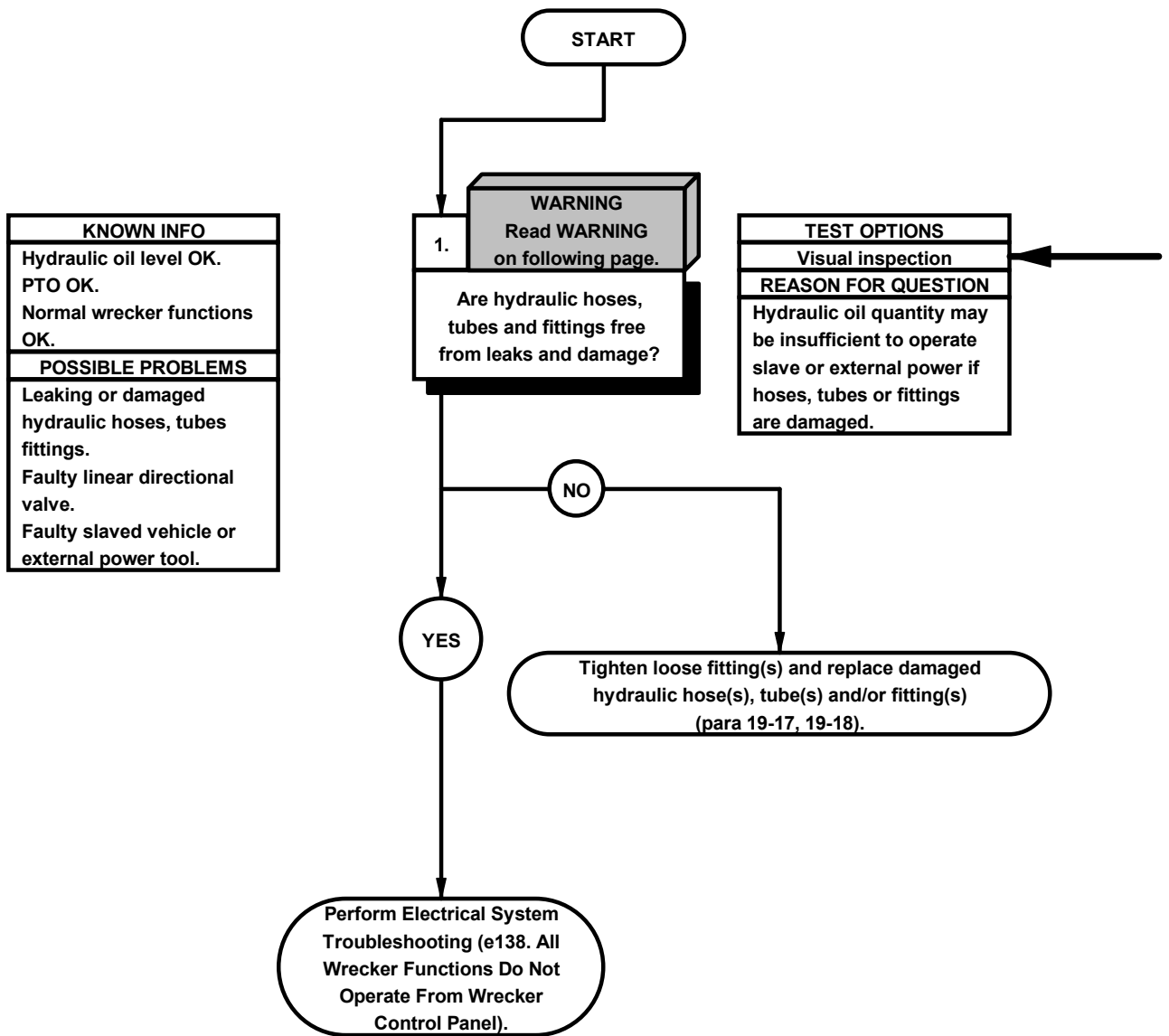

WARNING

- Drop hydraulic pressure to zero before disconnecting any hydraulic line. Failure to comply may result in injury to personnel.
- Wear approved eye protection when performing pressure checks. Failure to comply may result in oil getting into eyes. If oil contacts eyes, seek medical attention immediately.
- Fuel and oil are slippery and can cause falls. Wipe up spilled fuel or oil with rags. Failure to comply may result in injury to personnel.

- (1) Place drain pan under vehicle.
- (2) Remove four screws, lockwashers and washers from middle control panel cover. Discard lockwashers.
- (3) Remove two screws, washers, lockwashers, nuts and middle control panel cover from control panel. Discard lockwashers.
- (4) Check hydraulic hoses, tubes and fittings from linear directional valve to slave and external output ports.
- (5) Position middle control panel cover on control panel with two screws, washers and nuts.
- (6) Install four washers, lockwashers, and screws in middle control panel cover.

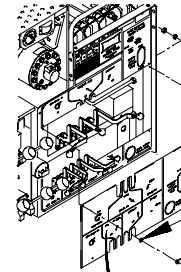
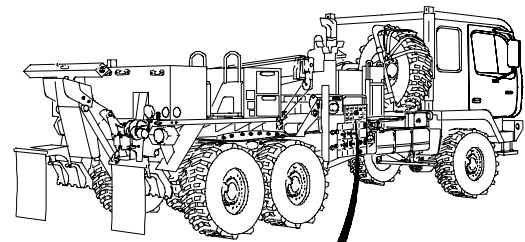

WASHER
LOCKWASHER
SCREW

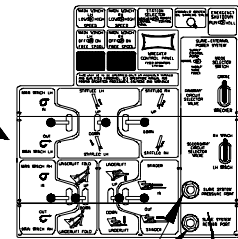

SLAVE POWER PORTS

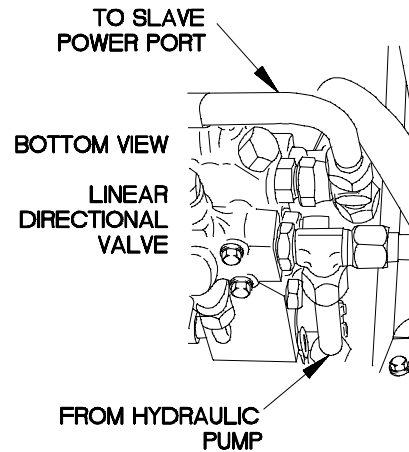

BOTTOM VIEW

LINEAR DIRECTIONAL VALVE

FROM HYDRAULIC PUMP

TO SLAVE POWER PORT

2-34. SPECIAL PURPOSE KIT TROUBLESHOOTING

This paragraph covers Special Purpose Kit Troubleshooting. The Special Purpose Kit Fault Index, Table 2-62, lists faults for the Special Purpose Kits of the vehicle.

Table 2-62. Special Purpose Kit Fault Index

Fault No.	Description	Page
x1.	Deleted	2-2272
x2.	Deleted	2-2274
x3.	Deleted	2-2280
x4.	Deleted	2-2290
x5.	Deleted	2-2296
x6.	Deleted	2-2298
x7.	Deleted	2-2304
x8.	Deleted	2-2310
x9.	Deleted	2-2314
x10.	Deleted	2-2324
x11.	Deleted	2-2326
x12.	Deleted	2-2332
x13.	Deleted	2-2344
x14.	Deleted	2-2354
x15.	Deleted	2-2356
x16.	Deleted	2-2362
x17.	Deleted	2-2368
x18.	Troop Transport Alarm Does Not Operate	2-2372
x19.	Light Material Handling Crane (LMHC) Does Not Operate	2-2382
x20.	Light Material Handling Crane (LMHC) Hoist In Does Not Operate	2-2400
x21.	Light Material Handling Crane (LMHC) Hoist Out Does Not Operate	2-2404

x18. TROOP TRANSPORT ALARM DOES NOT OPERATE	
INITIAL SETUP	
<p>Equipment Conditions Engine shut down (TM 9-2320-366-10-1).</p> <p>Personnel Required (2)</p>	<p>Tools and Special Tools Tool Kit, Genl Mech (Item 46, Appendix C) STE/ICE-R (Item 41, Appendix C) Multimeter, Digital (Item 22, Appendix C) Wrench, Torque, 0-200 lb-in. (Item 59, Appendix C) Wire, Elect, 50 ft (Item 71, Appendix D)</p> <p>References TM 9-4910-571-12&P</p>

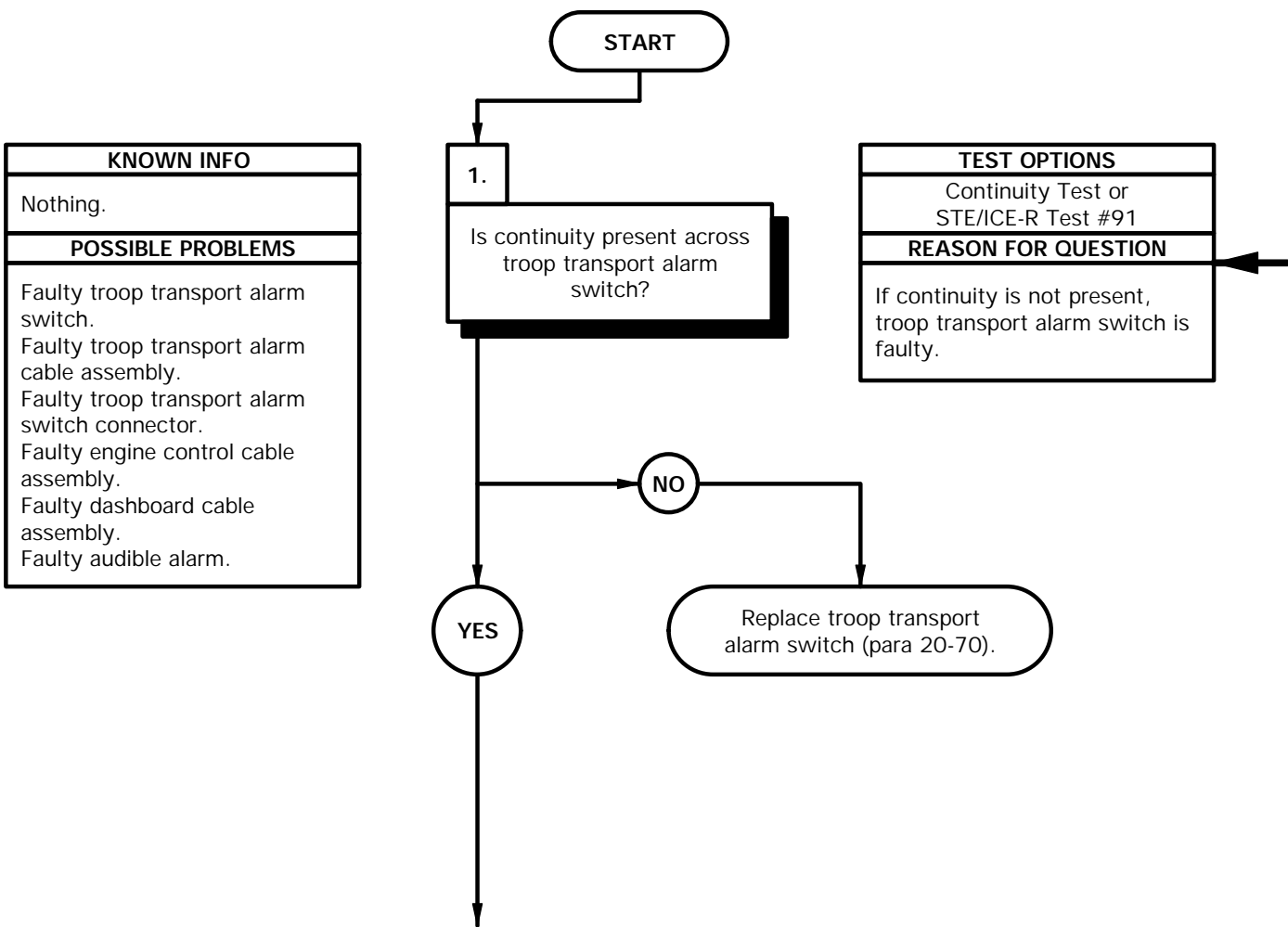

CONTINUITY TEST

- (1) Disconnect connector P921 from connector J921.
- (2) Set multimeter to ohms.
- (3) Connect positive (+) probe of multimeter to pin 1 of troop transport alarm switch.
- (4) Connect negative (-) probe of multimeter to pin 2 of troop transport alarm switch.
- (5) Press troop transport alarm switch and note reading on multimeter.
- (6) If continuity is not present, replace troop transport alarm switch (para 20-70).

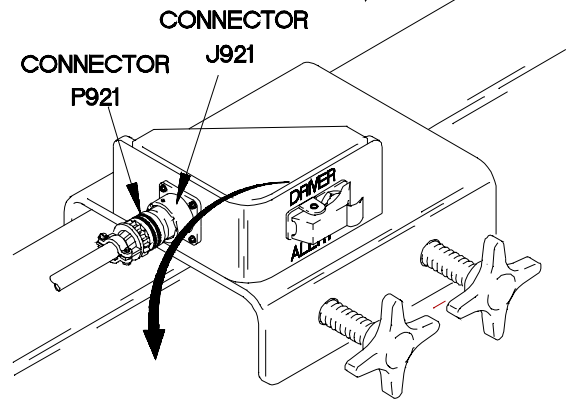
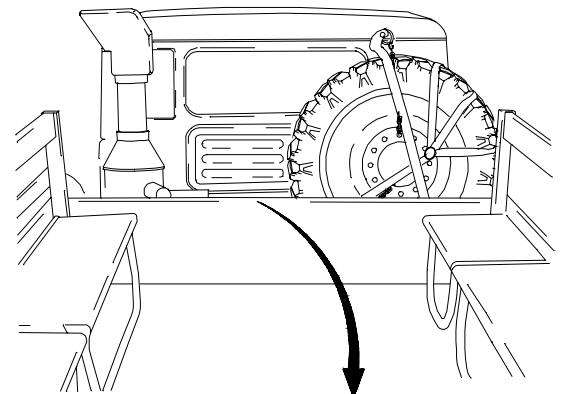

TROOP TRANSPORT ALARM SWITCH

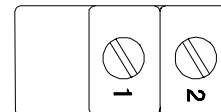

X2X23011

x18. TROOP TRANSPORT ALARM DOES NOT OPERATE (CONT)

KNOWN INFO
Troopseat alarm switch OK.
POSSIBLE PROBLEMS
Faulty troop transport alarm switch connector. Faulty troop transport alarm cable assembly. Faulty engine control cable assembly. Faulty dashboard cable assembly. Faulty audible alarm.

2.
Is continuity present from terminal lug TL164 to connector J921-A?

TEST OPTIONS
Continuity Test or STE/ICE-R #91
REASON FOR QUESTION
If continuity is not present, wire 32 is faulty.

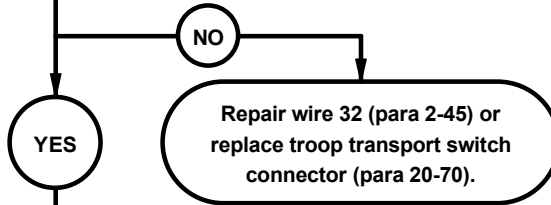

KNOWN INFO
Troop transport alarm switch OK.
POSSIBLE PROBLEMS
Faulty troop transport alarm switch connector. Faulty troop transport alarm cable assembly. Faulty engine control cable assembly. Faulty dashboard cable assembly. Faulty audible alarm.

3.
Is continuity present from terminal lug TL165 to connector J921-C?

TEST OPTIONS
Continuity Test or STE/ICE-R #91
REASON FOR QUESTION
If continuity is not present, wire 3028 is faulty.

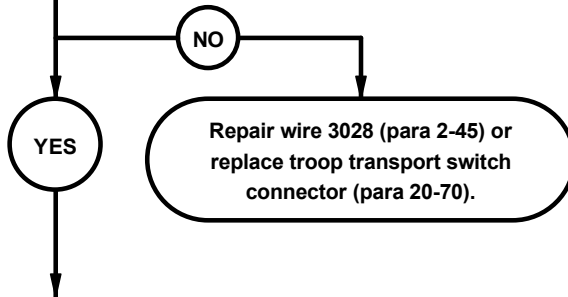

CONTINUITY TEST	
	(1) Set multimeter to ohms.
	(2) Connect positive (+) probe of multimeter to terminal lug TL164.
	(3) Connect negative (-) probe of multimeter to connector J921-A and note reading on multimeter.
	(4) If continuity is not present, repair wire 32 (para 2-45) or replace troop transport alarm switch connector (para 20-70).

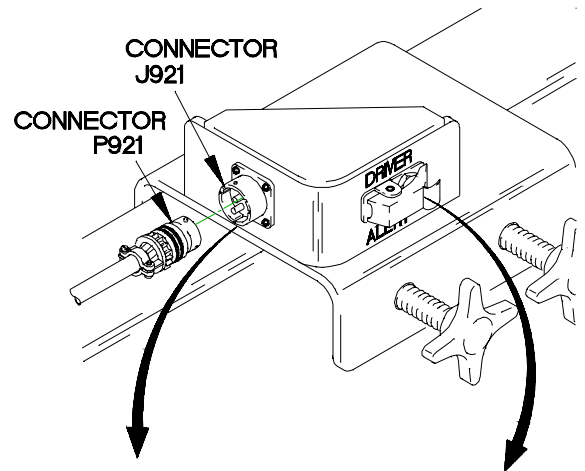

CONTINUITY TEST	
	(1) Set multimeter to ohms.
	(2) Connect positive (+) probe of multimeter to terminal lug TL165.
	(3) Connect negative (-) probe of multimeter to connector J921-C and note reading on multimeter.
	(4) If continuity is not present, repair wire 3028 (para 2-45) or replace troop transport alarm switch connector (para 20-70).

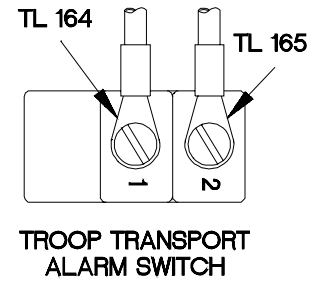
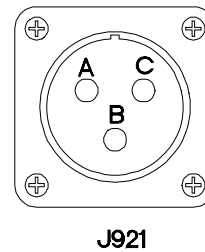

X2X23021

x18. TROOP TRANSPORT ALARM DOES NOT OPERATE (CONT)

KNOWN INFO
Troop transport alarm switch OK. Troop transport switch connector OK.
POSSIBLE PROBLEMS
Faulty troop transport alarm cable assembly. Faulty engine control cable assembly. Faulty dashboard cable assembly. Faulty audible alarm.

4.
Is continuity present from connector P921-A to connector J39-2?

TEST OPTIONS
Continuity Test or STE/ICE-R #91
REASON FOR QUESTION
If continuity is not present, wire 32 is faulty.

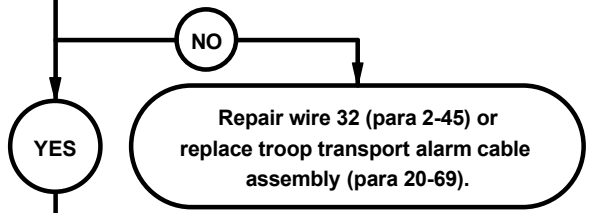

KNOWN INFO
Troop transport alarm switch OK. Troop transport alarm switch connector OK.
POSSIBLE PROBLEMS
Faulty troop transport alarm cable assembly. Faulty engine control cable assembly. Faulty dashboard cable assembly. Faulty audible alarm.

5.
Is continuity present from connector P921-C to connector J39-1?

TEST OPTIONS
Continuity Test or STE/ICE-R #91
REASON FOR QUESTION
If continuity is not present, wire 3028 is faulty.

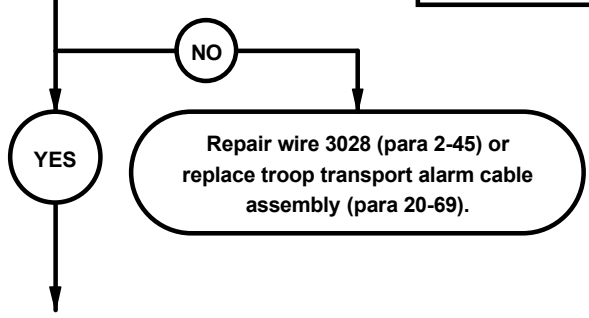

CONTINUITY TEST	
	(1) Set multimeter to ohms.
	(2) Disconnect connector clamp from connector J39.
	(3) Disconnect connector J39 from connector P39.
	(4) Connect positive (+) probe of multimeter to connector P921-A.
	(5) Connect negative (-) probe of multimeter to connector J39-2 and note reading on multimeter.
	(6) If continuity is not present, repair wire 32 (para 2-45) or replace troop transport alarm cable assembly (para 20-69).

CONTINUITY TEST	
	(1) Set multimeter to ohms.
	(2) Connect positive (+) probe of multimeter to connector P921-C.
	(3) Connect negative (-) probe of multimeter to connector J39-1 and note reading on multimeter.
	(4) If continuity is not present, repair wire 3028 (para 2-45) or replace troop transport alarm cable assembly (para 20-69).
	(5) Connect connector P921 to connector J921.

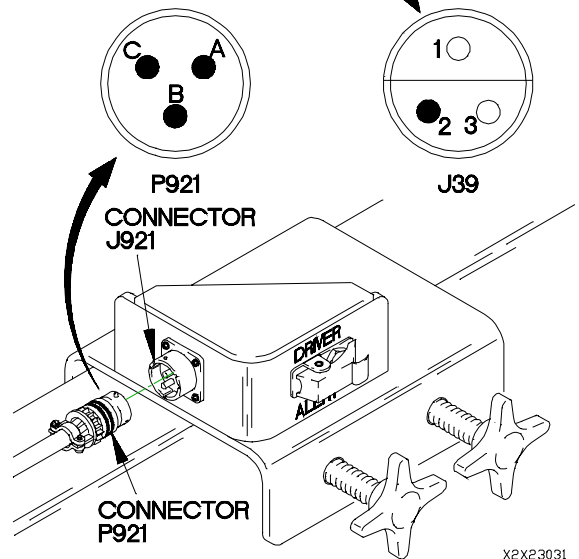
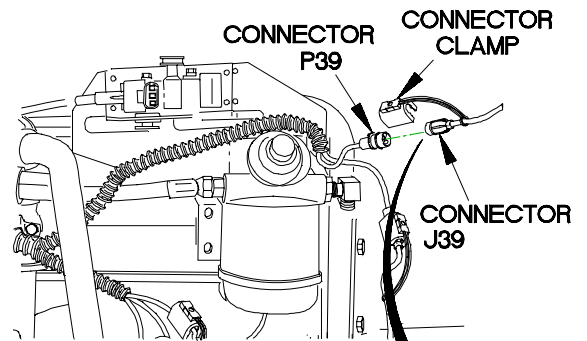

X2X23031

x18. TROOP TRANSPORT ALARM DOES NOT OPERATE (CONT)

KNOWN INFO
Troop transport alarm switch OK. Troop transport alarm switch connector OK. Troop transport alarm cable assembly OK.
POSSIBLE PROBLEMS
Faulty engine control cable assembly. Faulty dashboard cable assembly. Faulty audible alarm.

KNOWN INFO
Troop transport alarm switch OK. Troop transport alarm switch connector OK. Troop transport alarm cable assembly OK.
POSSIBLE PROBLEMS
Faulty engine control cable assembly. Faulty dashboard cable assembly. Faulty audible alarm.

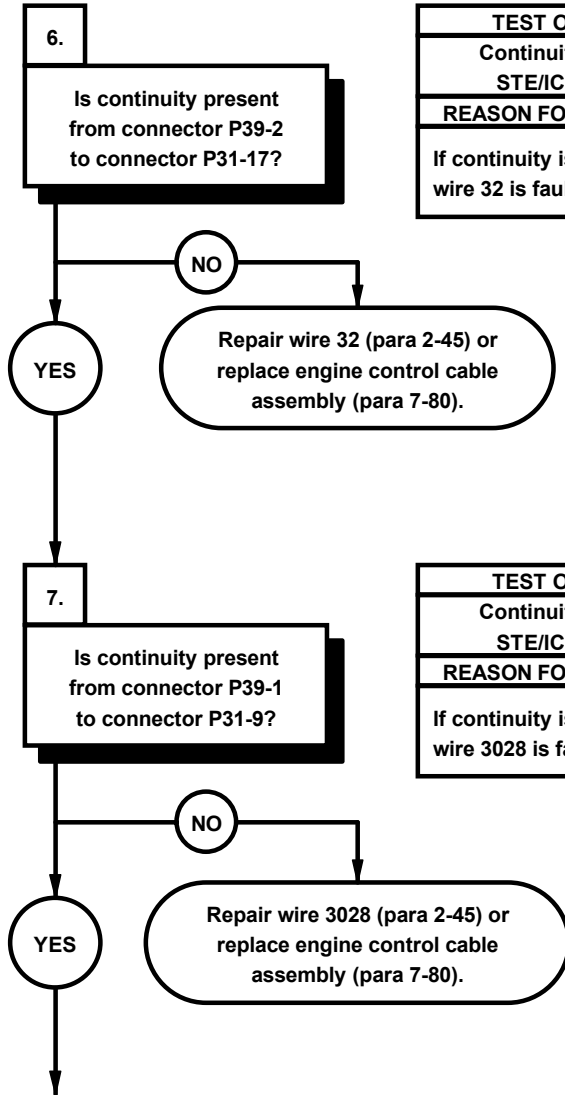

TEST OPTIONS
Continuity Test or STE/ICE-R #91
REASON FOR QUESTION
If continuity is not present, wire 32 is faulty.

TEST OPTIONS
Continuity Test or STE/ICE-R #91
REASON FOR QUESTION
If continuity is not present, wire 3028 is faulty.

CONTINUITY TEST

- (1) Lift instrument panel assembly outward to gain access (para 7-15).
- (2) Disconnect connector P31 from connector J31.
- (3) Set multimeter to ohms.
- (4) Connect positive (+) probe of multimeter to connector P39-2.
- (5) Connect negative (-) probe of multimeter to connector P31-17 and note reading on multimeter.
- (6) If continuity is not present, repair wire 32 (para 2-45) or replace engine control cable assembly (para 7-80).

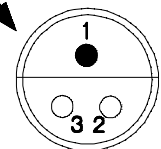
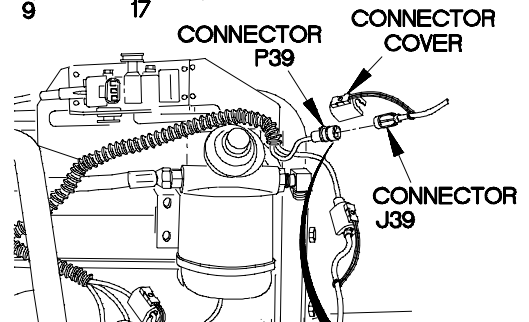
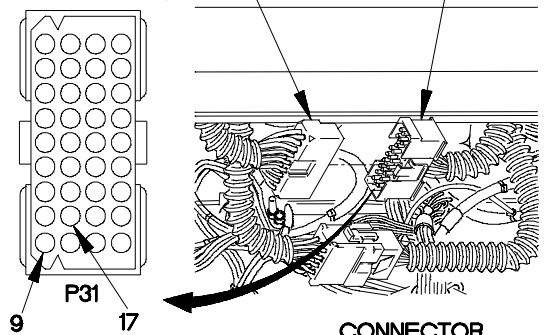
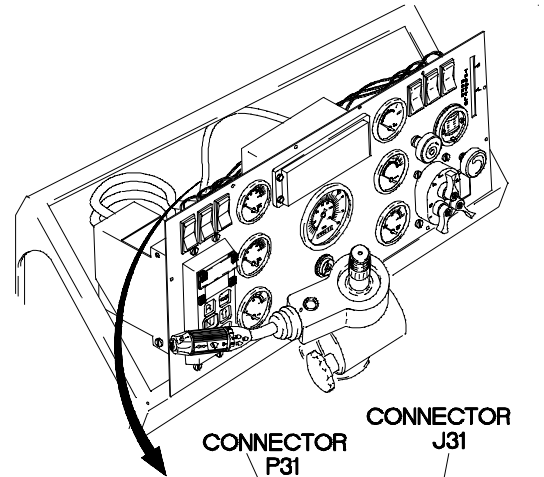

P39 X2x23041

CONTINUITY TEST

- (1) Set multimeter to ohms.
- (2) Connect positive (+) probe of multimeter to connector P39-1.
- (3) Connect negative (-) probe of multimeter to connector P31-9 and note reading on multimeter.
- (4) If continuity is not present, repair wire 3028 (para 2-45) or replace engine control cable assembly (para 7-80).
- (5) Connect connector P39 to connector J39.
- (6) Connect connector clamp to connector J39.

x18. TROOP TRANSPORT ALARM DOES NOT OPERATE (CONT)

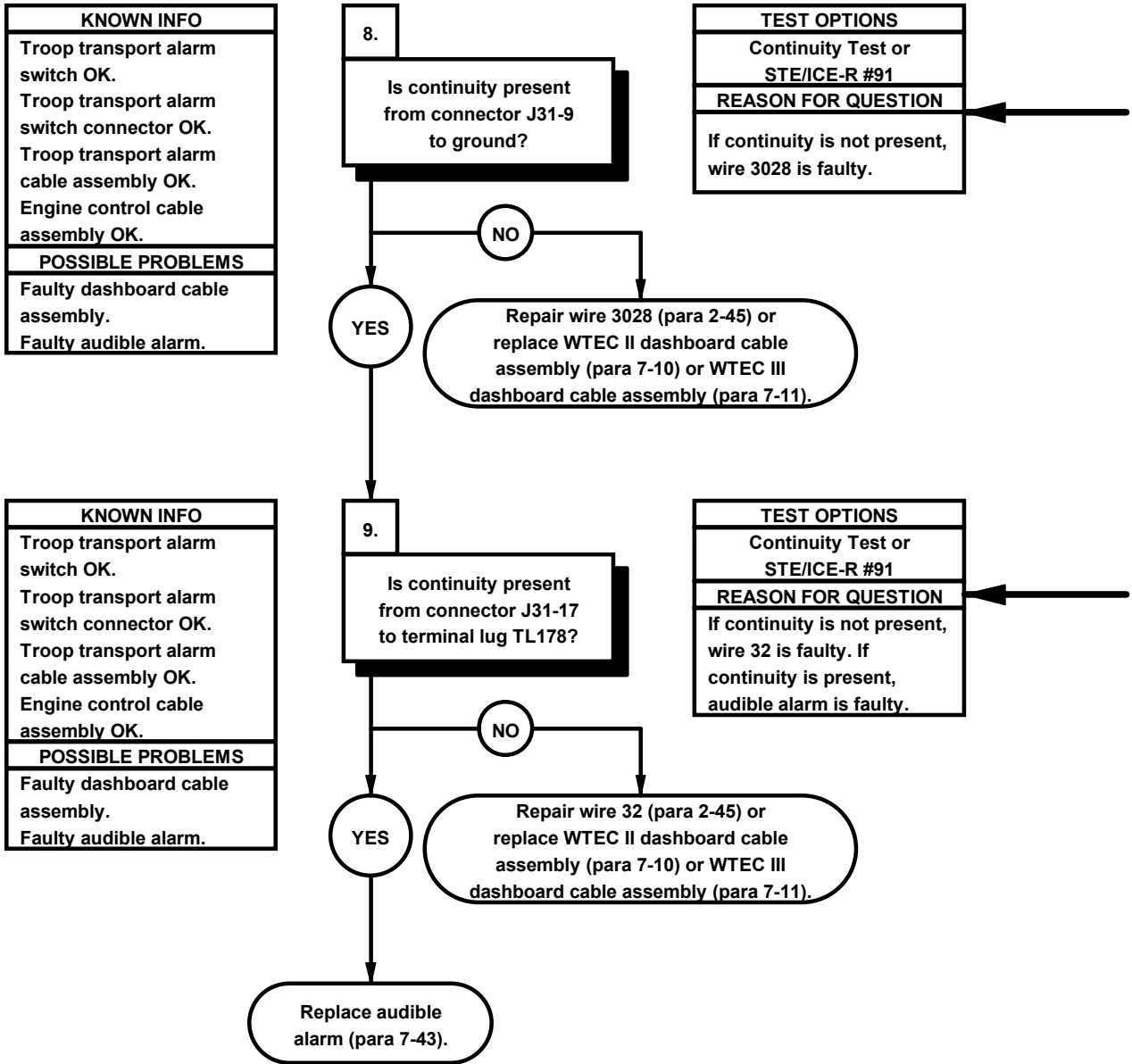

CONTINUITY TEST

- (1) Set multimeter to ohms.
- (2) Connect positive (+) probe of multimeter to connector J31-9.
- (3) Connect negative (-) probe of multimeter to ground and note reading on multimeter.
- (4) If continuity is not present, repair wire 3028 (para 2-45) or replace WTEC II dashboard cable assembly (para 7-10) or WTEC III dashboard cable assembly (para 7-11).

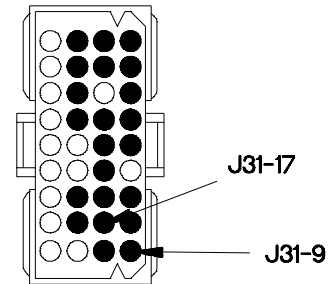

CONTINUITY TEST

- (1) Remove screw and terminal lug TL178 from audible alarm.
- (2) Set multimeter to ohms.
- (3) Connect positive (+) probe of multimeter to connector J31-17.
- (4) Connect negative (-) probe of multimeter to terminal lug TL178 and note reading on multimeter.
- (5) If continuity is not present, repair wire 32 (para 2-45) or replace WTEC II dashboard cable assembly (para 7-10) or WTEC III dashboard cable assembly (para 7-11).
- (6) If continuity is present, replace audible alarm (para 7-43).
- (7) Install terminal lug TL178 on audible alarm with screw.
- (8) Connect connector P31 to connector J31.
- (9) Install instrument panel assembly (para 7-15).

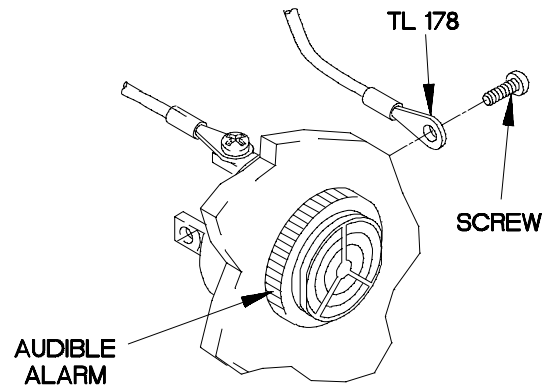

X2x23051

x19. LIGHT MATERIAL HANDLING CRANE (LMHC) DOES NOT OPERATE	
INITIAL SETUP	
Equipment Conditions Engine shut down (TM 9-2320-366-10-1).	Tools and Special Tools Tool Kit, Genl Mech (Item 46, Appendix C) STE/ICE-R (Item 41, Appendix C) Multimeter, Digital (Item 22, Appendix C)
Personnel Required (2)	References TM 9-4910-571-12&P

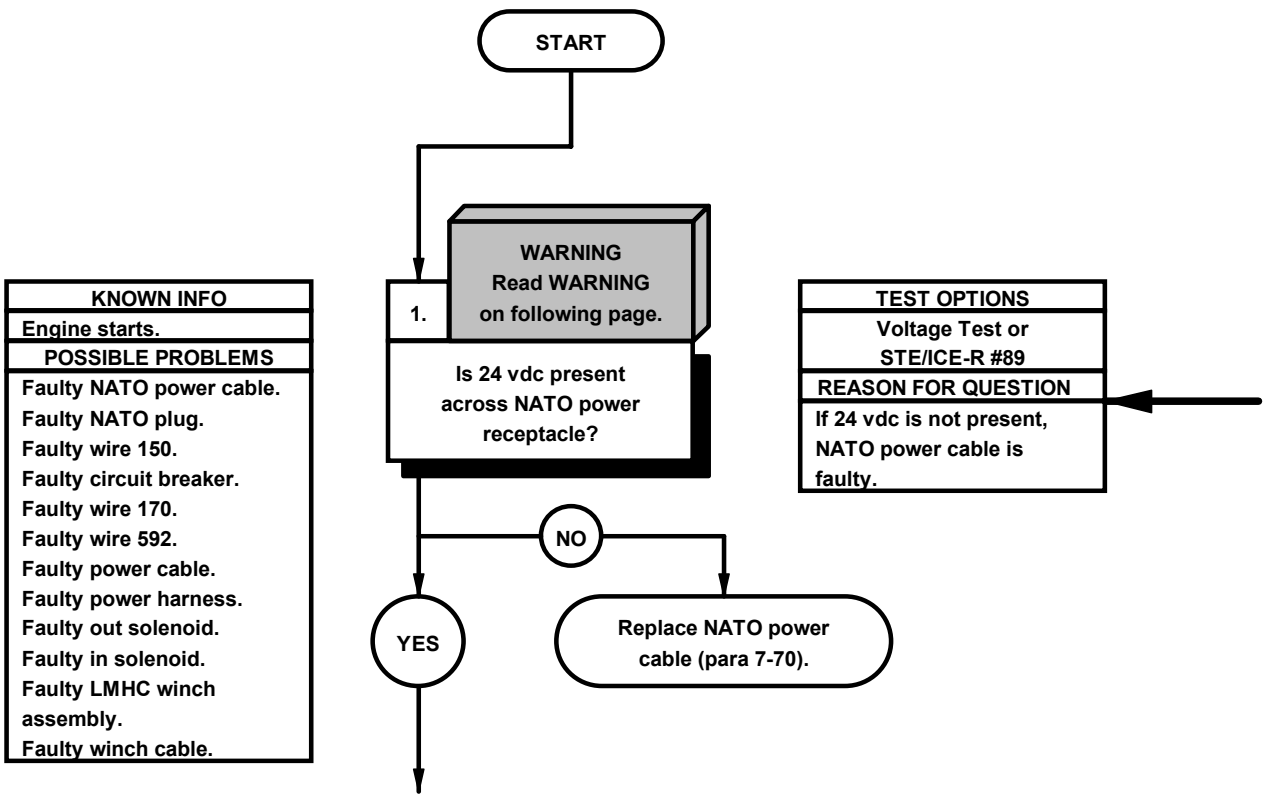

WARNING

Remove rings, bracelets, watches, necklaces, and any other jewelry before working around vehicle. Jewelry can catch on equipment and cause injury or short across electrical circuit and cause severe burns or electrical shock. Batteries can explode from a spark. Battery acid is harmful to skin and eyes. Always wear eye protection when working with batteries.

VOLTAGE TEST

- (1) Disconnect NATO plug from NATO power cable receptacle.
- (2) Set multimeter to volts dc.
- (3) Connect positive (+) probe of multimeter to inside of NATO power cable receptacle.
- (4) Connect negative (-) probe of multimeter to outside of NATO power cable receptacle and note reading on multimeter.
- (5) If 24 vdc is not present, replace NATO power cable (para 7-70).

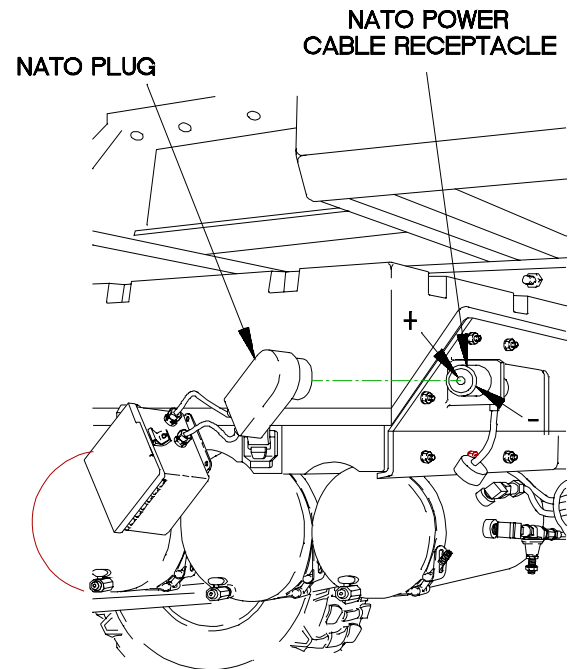

X2X24011

x19. LIGHT MATERIAL HANDLING CRANE (LMHC) DOES NOT OPERATE (CONT)

KNOWN INFO
Engine starts. NATO power cable OK.
POSSIBLE PROBLEMS
Faulty NATO plug. Faulty wire 150. Faulty circuit breaker. Faulty wire 170. Faulty wire 592. Faulty power cable. Faulty power harness. Faulty out solenoid. Faulty in solenoid. Faulty LMHC winch assembly. Faulty winch cable.

KNOWN INFO
Engine starts. NATO power cable OK.
POSSIBLE PROBLEMS
Faulty NATO plug. Faulty wire 150. Faulty circuit breaker. Faulty wire 170. Faulty wire 592. Faulty power cable. Faulty power harness. Faulty out solenoid. Faulty in solenoid. Faulty LMHC winch assembly. Faulty winch cable.

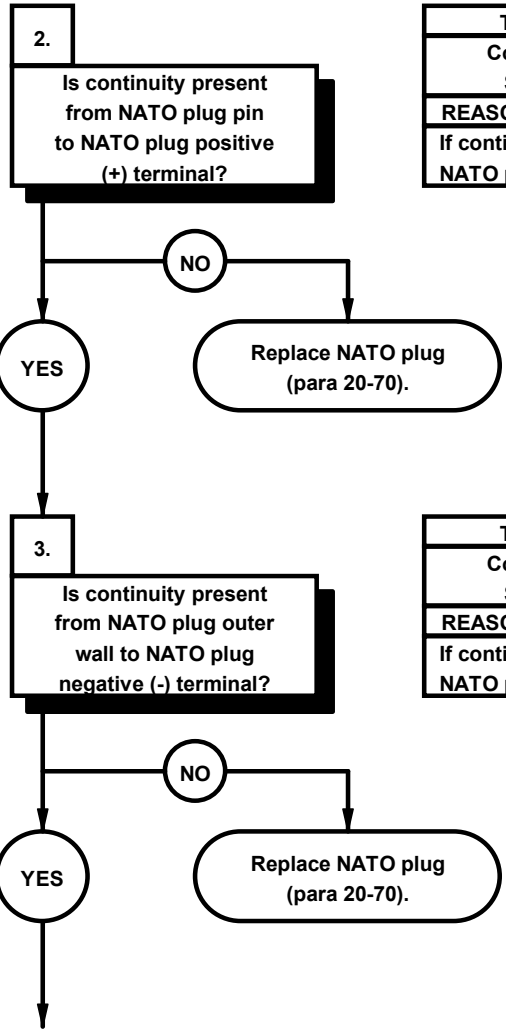

TEST OPTIONS
Continuity Test or STE/ICE-R #91
REASON FOR QUESTION
If continuity is not present, NATO plug is faulty.

TEST OPTIONS
Continuity Test or STE/ICE-R #91
REASON FOR QUESTION
If continuity is not present, NATO plug is faulty.

- | CONTINUITY TEST | |
|-----------------|---|
| | (1) Remove eight screws, cover, and retainer from NATO plug. |
| | (2) Set multimeter to ohms. |
| | (3) Connect positive (+) probe of multimeter to NATO plug pin. |
| | (4) Connect negative (-) probe of multimeter to NATO plug positive (+) terminal lug and note reading on multimeter. |
| | (5) If continuity is not present, replace NATO plug (para 20-70). |

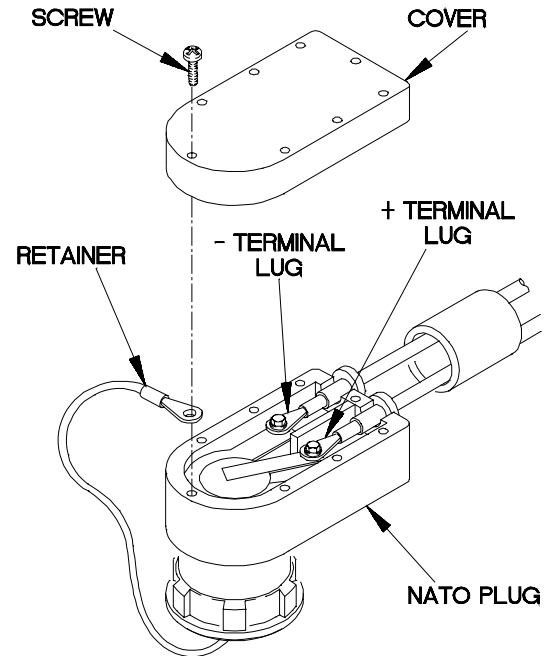

- | CONTINUITY TEST | |
|-----------------|---|
| | (1) Set multimeter to ohms. |
| | (2) Connect positive (+) probe of multimeter to NATO plug outer wall. |
| | (3) Connect negative (-) probe of multimeter to NATO plug negative (-) terminal lug and note reading on multimeter. |
| | (4) If continuity is not present, replace NATO plug (para 20-70). |

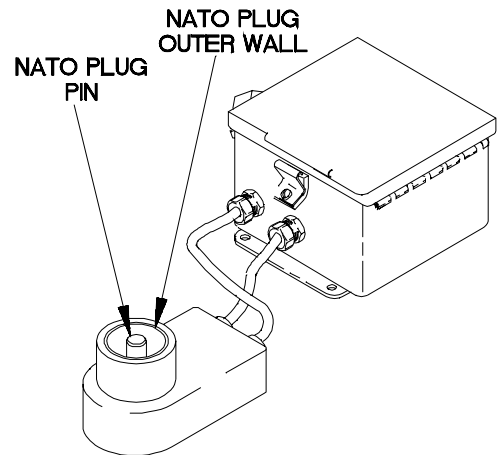

X2X24021

x19. LIGHT MATERIAL HANDLING CRANE (LMHC) DOES NOT OPERATE (CONT)

KNOWN INFO
Engine starts. NATO power cable OK. NATO plug OK.
POSSIBLE PROBLEMS
Faulty wire 170. Faulty circuit breaker. Faulty wire 150. Faulty wire 592. Faulty power cable. Faulty power harness. Faulty out solenoid. Faulty in solenoid. Faulty LMHC winch assembly. Faulty winch cable.

KNOWN INFO
Engine starts. NATO power cable OK. NATO plug OK. Wire 170 OK.
POSSIBLE PROBLEMS
Faulty wire 150. Faulty circuit breaker. Faulty wire 592. Faulty power cable. Faulty power harness. Faulty out solenoid. Faulty in solenoid. Faulty LMHC winch assembly. Faulty winch cable.

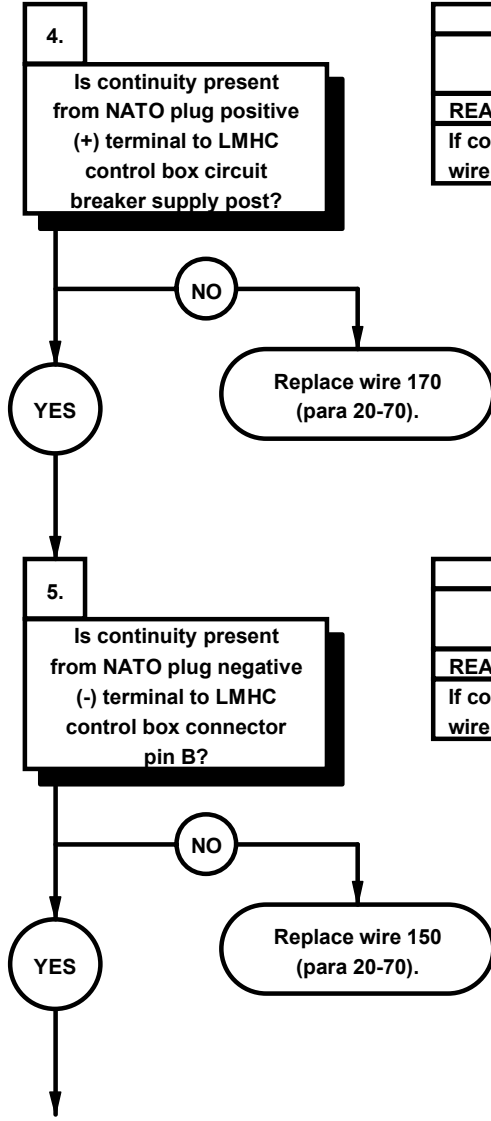

TEST OPTIONS
Continuity Test or STE/ICE-R #91
REASON FOR QUESTION
If continuity is not present, wire 170 is faulty.

TEST OPTIONS
Continuity Test or STE/ICE-R #91
REASON FOR QUESTION
If continuity is not present, wire 150 is faulty.

CONTINUITY TEST	
	(1) Open cover on LMHC control box.
	(2) Set multimeter to ohms.
	(3) Connect positive (+) probe of multimeter to NATO plug positive (+) terminal.
	(4) Connect negative (-) probe of multimeter to LMHC control box circuit breaker supply post and note reading on multimeter.
	(5) If continuity is not present, replace wire 170 (para 20-70).

CONTINUITY TEST	
	(1) Disconnect LMHC control box power cable from LMHC control box connector.
	(2) Set multimeter to ohms.
	(3) Connect positive (+) probe of multimeter to NATO plug negative (-) terminal.
	(4) Connect negative (-) probe of multimeter to LMHC control box connector pin B and note reading on multimeter.
	(5) If continuity is not present, replace wire 150 (para 20-70).
	(6) Install cover and retainer on NATO plug with eight screws.

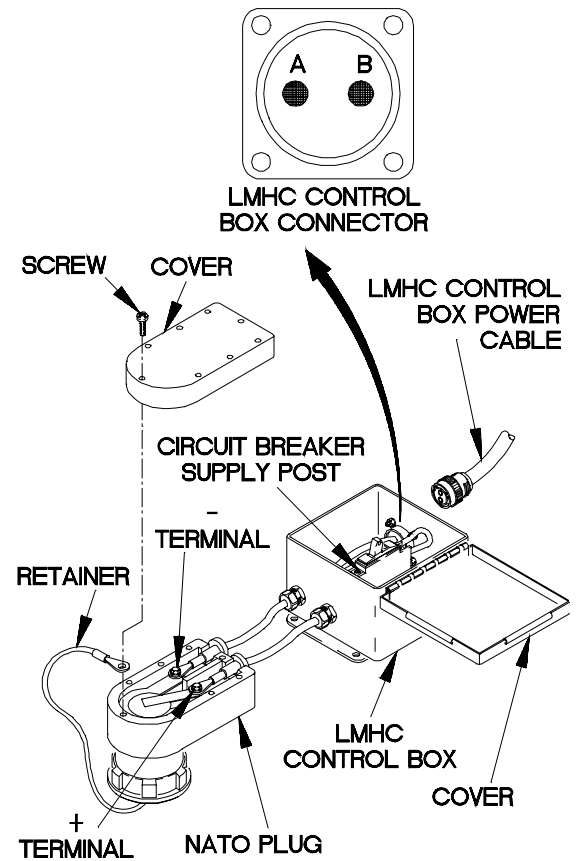

X2X24031

x19. LIGHT MATERIAL HANDLING CRANE (LMHC) DOES NOT OPERATE (CONT)

KNOWN INFO
Engine starts. NATO power cable OK. NATO plug OK. Wire 170 OK. Wire 150 OK.
POSSIBLE PROBLEMS
Faulty circuit breaker. Faulty wire 592. Faulty power cable. Faulty power harness. Faulty out solenoid. Faulty in solenoid. Faulty LMHC winch assembly. Faulty winch cable.

KNOWN INFO
Engine starts. NATO power cable OK. NATO plug OK. Wire 170 OK. Wire 150 OK. Circuit breaker OK.
POSSIBLE PROBLEMS
Faulty wire 592. Faulty power cable. Faulty power harness. Faulty out solenoid. Faulty in solenoid. Faulty LMHC winch assembly. Faulty winch cable.

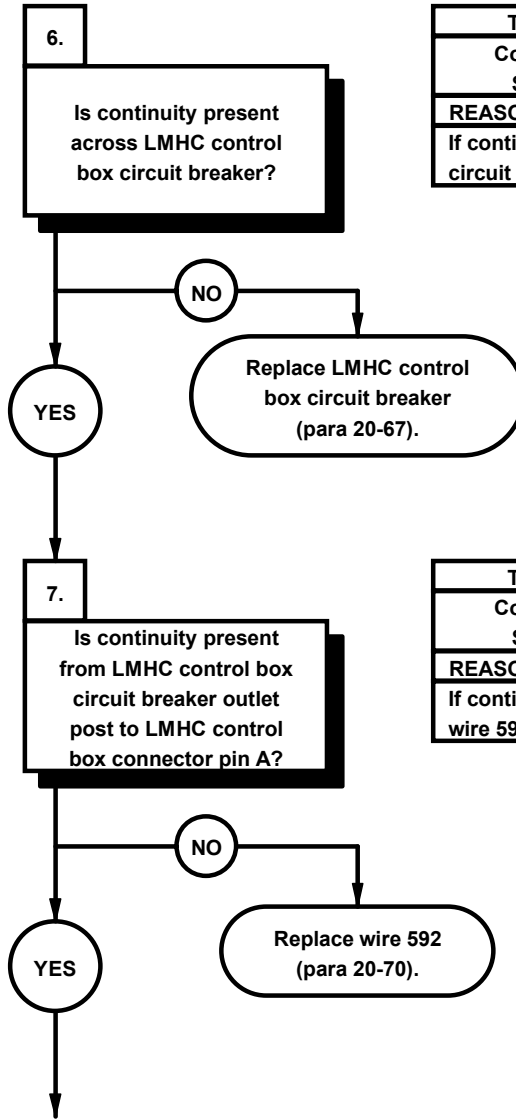

TEST OPTIONS
Continuity Test or STE/ICE-R #91
REASON FOR QUESTION
If continuity is not present, circuit breaker is faulty.

TEST OPTIONS
Continuity Test or STE/ICE-R #91
REASON FOR QUESTION
If continuity is not present, wire 592 is faulty.

CONTINUITY TEST

- (1) Set multimeter to ohms.
- (2) Connect positive (+) probe of multimeter to one end of LMHC control box circuit breaker.
- (3) Connect negative (-) probe of multimeter to other end of LMHC control box circuit breaker.
- (4) Position LMHC control box circuit breaker to ON and note reading on multimeter.
- (5) If continuity is not present, replace LMHC control box circuit breaker (para 20-67).
- (6) Position LMHC control box circuit breaker to OFF.

CONTINUITY TEST

- (1) Set multimeter to ohms.
- (2) Connect positive (+) probe of multimeter to LMHC control box circuit breaker outlet post.
- (3) Connect negative (-) probe of multimeter to LMHC control box connector pin A and note reading on multimeter.
- (4) If continuity is not present, replace wire 592 (para 20-70).
- (5) Close cover on LMHC control box.
- (6) Connect LMHC control box power cable to LMHC control box connector.

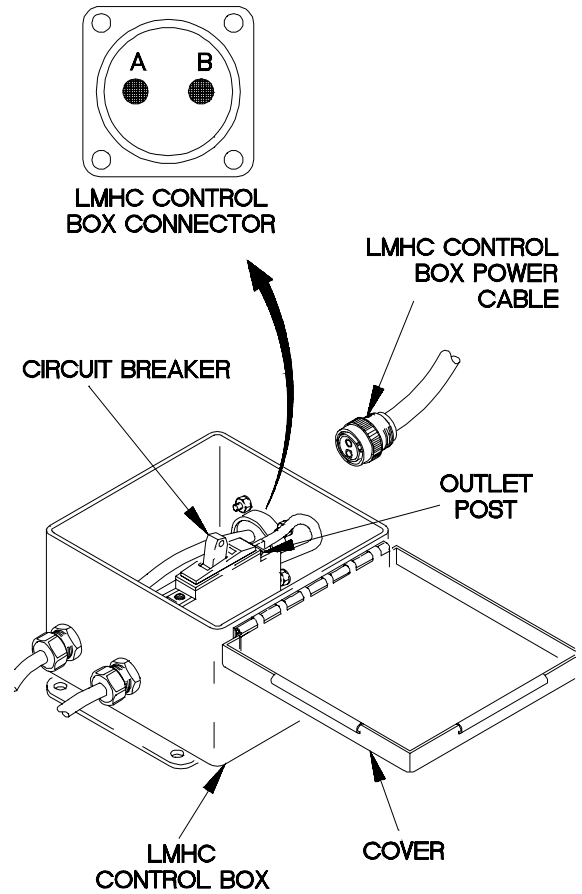

X2X27011

x19. LIGHT MATERIAL HANDLING CRANE (LMHC) DOES NOT OPERATE (CONT)

KNOWN INFO
Engine starts. NATO power cable OK. NATO plug OK. Wire 170 OK. Wire 150 OK. Circuit breaker OK. Wire 592 OK.
POSSIBLE PROBLEMS
Faulty power cable. Faulty power harness. Faulty out solenoid. Faulty in solenoid. Faulty LMHC winch assembly. Faulty winch cable.

KNOWN INFO
Engine starts. NATO power cable OK. NATO plug OK. Wire 170 OK. Wire 150 OK. Circuit breaker OK. Wire 592 OK.
POSSIBLE PROBLEMS
Faulty power cable. Faulty power harness. Faulty out solenoid. Faulty in solenoid. Faulty LMHC winch assembly. Faulty winch cable.

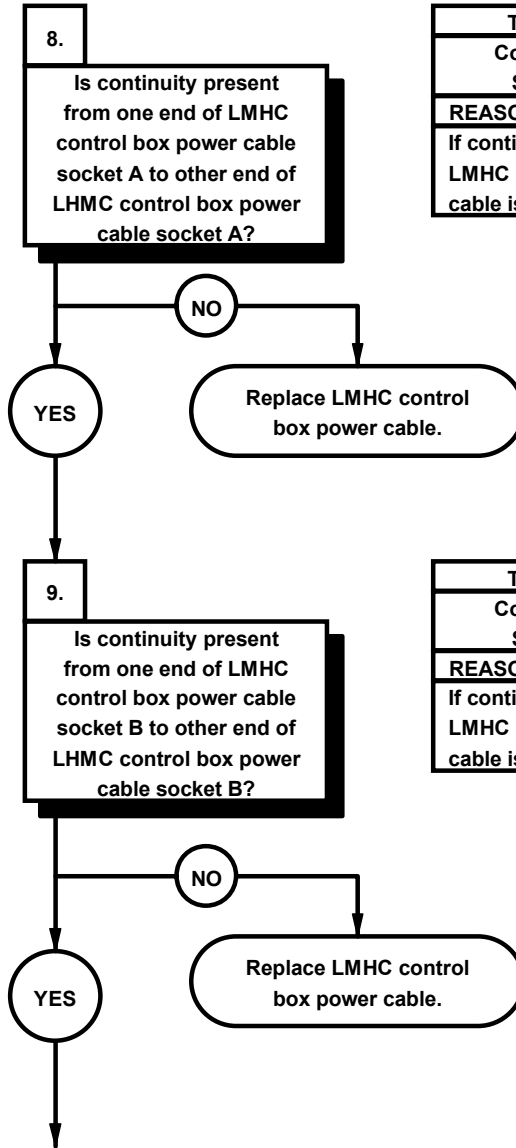

TEST OPTIONS
Continuity Test or STE/ICE-R #91
REASON FOR QUESTION
If continuity is not present, LMHC control box power cable is faulty.

TEST OPTIONS
Continuity Test or STE/ICE-R #91
REASON FOR QUESTION
If continuity is not present, LMHC control box power cable is faulty.

CONTINUITY TEST	
—	<ol style="list-style-type: none"> (1) Disconnect LMHC control power cable from LMHC winch assembly power connector. (2) Set multimeter to ohms. (3) Connect positive (+) probe of multimeter to one end of LMHC control box power cable socket A. (4) Connect negative (-) probe of multimeter to other end of LMHC control box power cable socket A and note reading on multimeter. (5) If continuity is not present, replace LMHC control box power cable.

CONTINUITY TEST	
—	<ol style="list-style-type: none"> (1) Set multimeter to ohms. (2) Connect positive (+) probe of multimeter to LMHC control box power cable socket B. (3) Connect negative (-) probe of multimeter to LMHC control box power cable socket B and note reading on multimeter. (4) If continuity is not present, replace LMHC control box power cable.

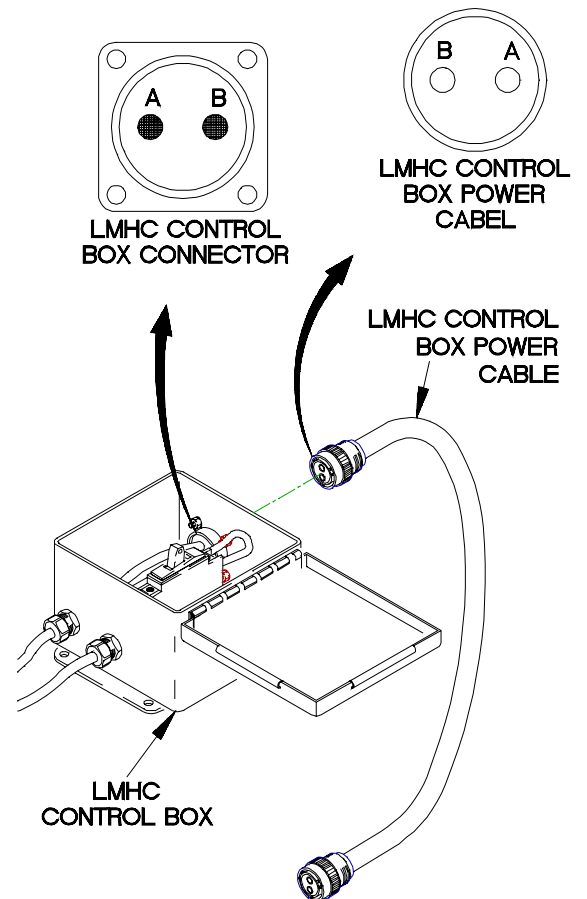

X2X24041

x19. LIGHT MATERIAL HANDLING CRANE (LMHC) DOES NOT OPERATE (CONT)

KNOWN INFO
Engine starts. NATO power cable OK. NATO plug OK. Wire 170 OK. Wire 150 OK. Circuit breaker OK. Wire 592 OK. Power cable OK.
POSSIBLE PROBLEMS
Faulty power harness. Faulty out solenoid. Faulty in solenoid. Faulty LMHC winch assembly. Faulty winch cable.

KNOWN INFO
Engine starts. NATO power cable OK. NATO plug OK. Wire 170 OK. Wire 150 OK. Circuit breaker OK. Wire 592 OK. Power cable OK.
POSSIBLE PROBLEMS
Faulty out solenoid. Faulty power harness. Faulty in solenoid. Faulty LMHC winch assembly. Faulty winch cable.

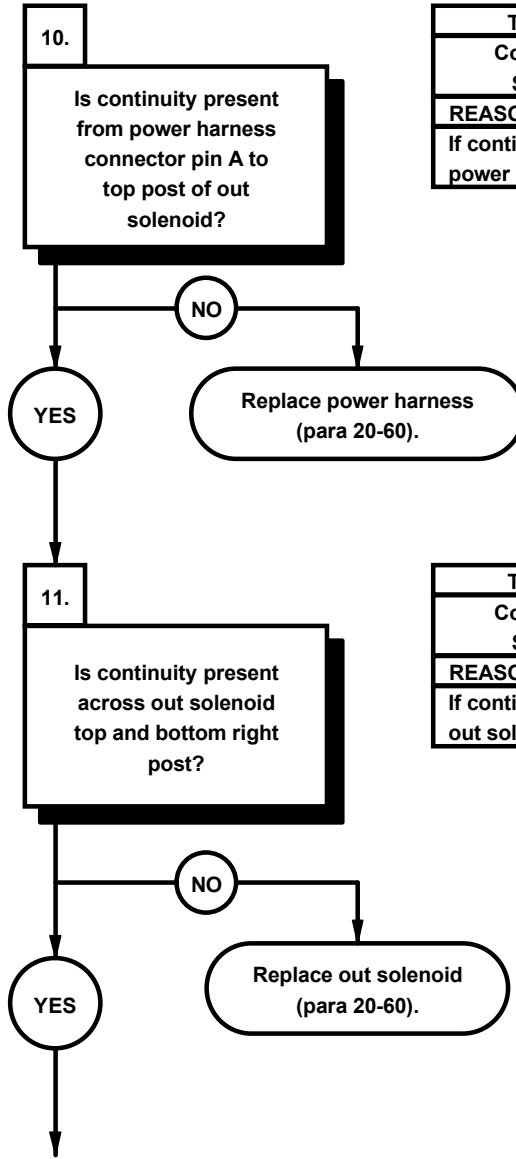

TEST OPTIONS
Continuity Test or STE/ICE-R #91
REASON FOR QUESTION
If continuity is not present, power harness is faulty.

TEST OPTIONS
Continuity Test or STE/ICE-R #91
REASON FOR QUESTION
If continuity is not present, out solenoid is faulty.

CONTINUITY TEST

- (1) Remove 18 screws and cover from base plate.
- (2) Set multimeter to ohms.
- (3) Connect positive (+) probe of multimeter to power harness connector pin A.
- (4) Connect negative (-) probe of multimeter to top post of out solenoid and note reading on multimeter.
- (5) If continuity is not present, replace power harness (para 20-60).

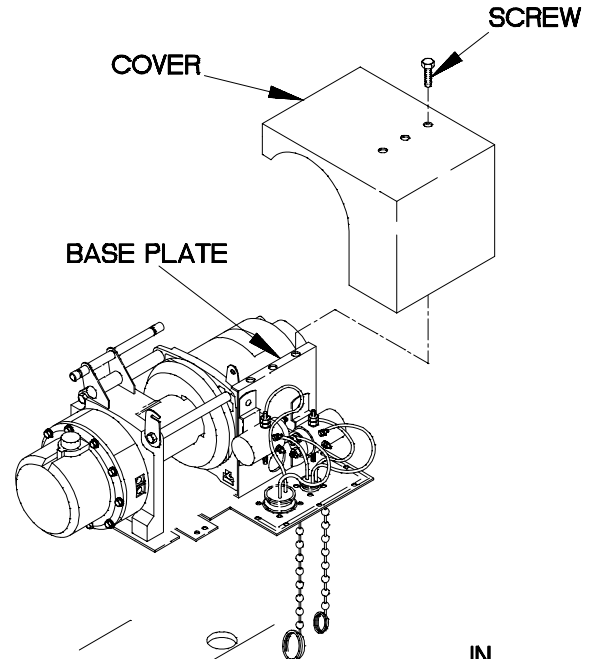

CONTINUITY TEST

- (1) Set multimeter to ohms.
- (2) Connect positive (+) probe of multimeter to top right post of out solenoid.
- (3) Connect negative (-) probe of multimeter to bottom right post of out solenoid and note reading on multimeter.
- (4) If continuity is not present, replace out solenoid (para 20-60).

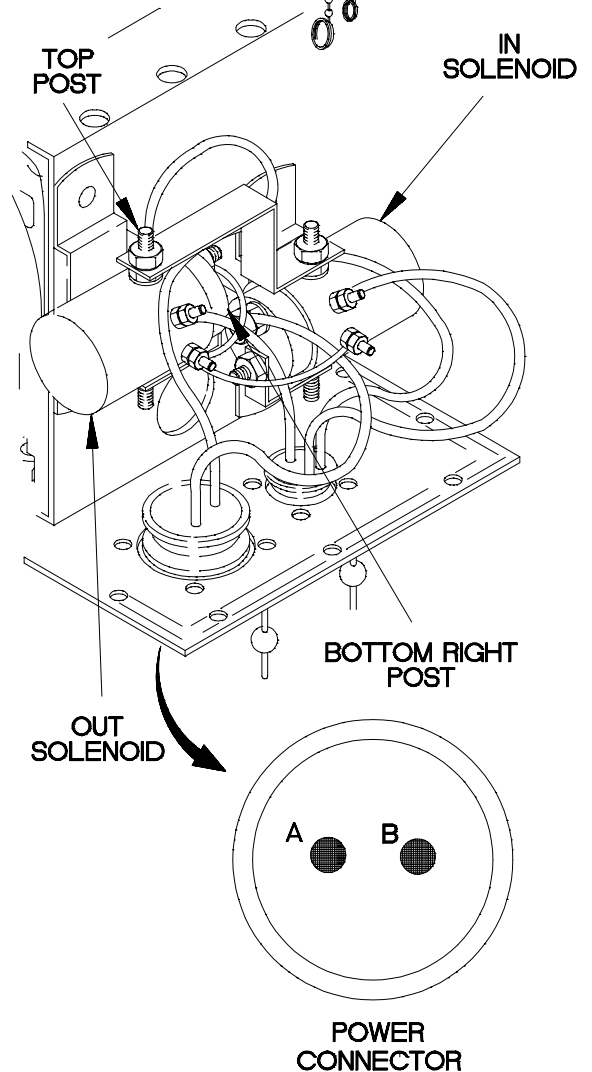

X2x25011

x19. LIGHT MATERIAL HANDLING CRANE (LMHC) DOES NOT OPERATE (CONT)

KNOWN INFO
Engine starts. NATO power cable OK. NATO plug OK. Wire 170 OK. Wire 150 OK. Circuit breaker OK. Wire 592 OK. Power cable OK. Out solenoid OK.
POSSIBLE PROBLEMS
Faulty power harness. Faulty in solenoid. Faulty LMHC winch assembly. Faulty winch cable.

KNOWN INFO
Engine starts. NATO power cable OK. NATO plug OK. Wire 170 OK. Wire 150 OK. Circuit breaker OK. Wire 592 OK. Power cable OK. Out solenoid OK.
POSSIBLE PROBLEMS
Faulty power harness. Faulty in solenoid. Faulty LMHC winch assembly. Faulty winch cable.

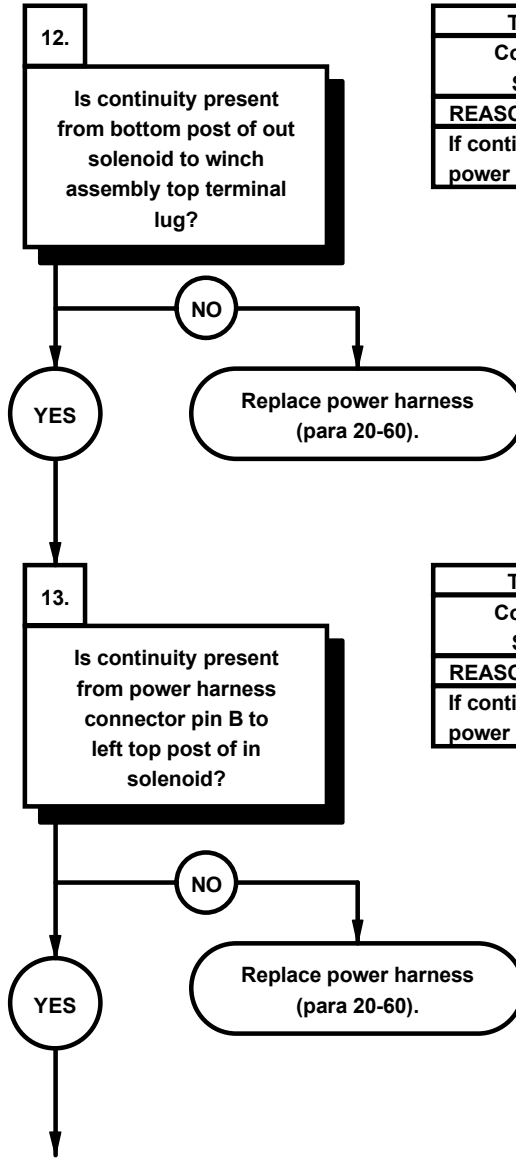

TEST OPTIONS
Continuity Test or STE/ICE-R #91
REASON FOR QUESTION
If continuity is not present, power harness is faulty.

TEST OPTIONS
Continuity Test or STE/ICE-R #91
REASON FOR QUESTION
If continuity is not present, power harness is faulty.

CONTINUITY TEST	
	(1) Set multimeter to ohms.
	(2) Connect positive (+) probe of multimeter to bottom post of out solenoid.
	(3) Connect negative (-) probe of multimeter to winch assembly top terminal lug and note reading on multimeter.
	(4) If continuity is not present, replace power harness (para 20-60).

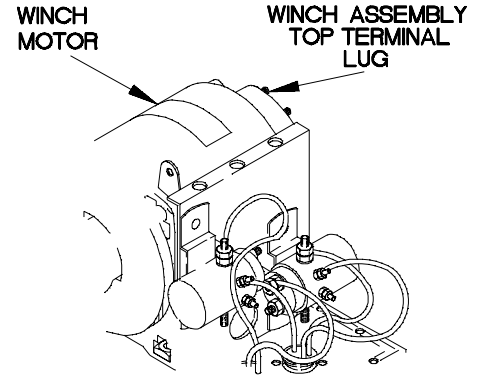

CONTINUITY TEST	
	(1) Set multimeter to ohms.
	(2) Connect positive (+) probe of multimeter to power harness connector pin B.
	(3) Connect negative (-) probe of multimeter to left top post of in solenoid and note reading on multimeter.
	(4) If continuity is not present, replace power harness (para 20-60).

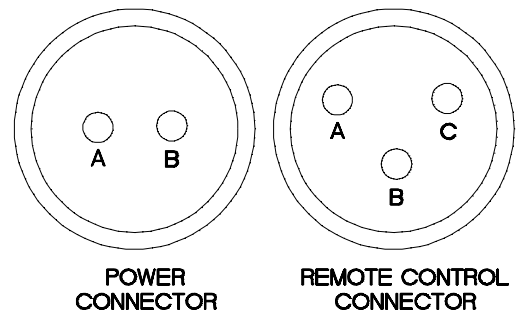
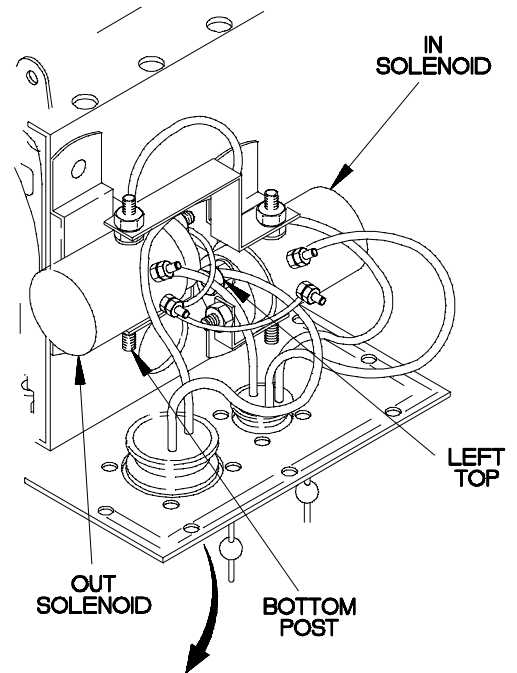

X2x2502A

x19. LIGHT MATERIAL HANDLING CRANE (LMHC) DOES NOT OPERATE (CONT)

KNOWN INFO
Engine starts. NATO power cable OK. NATO plug OK. Wire 170 OK. Wire 150 OK. Circuit breaker OK. Wire 592 OK. Power cable OK. Out solenoid OK.
POSSIBLE PROBLEMS
Faulty in solenoid. Faulty power harness. Faulty LMHC winch assembly. Faulty winch cable.

KNOWN INFO
Engine starts. NATO power cable OK. NATO plug OK. Wire 170 OK. Wire 150 OK. Circuit breaker OK. Wire 592 OK. Power cable OK. Out solenoid OK. In solenoid OK.
POSSIBLE PROBLEMS
Faulty power harness. Faulty LMHC winch assembly. Faulty winch cable.

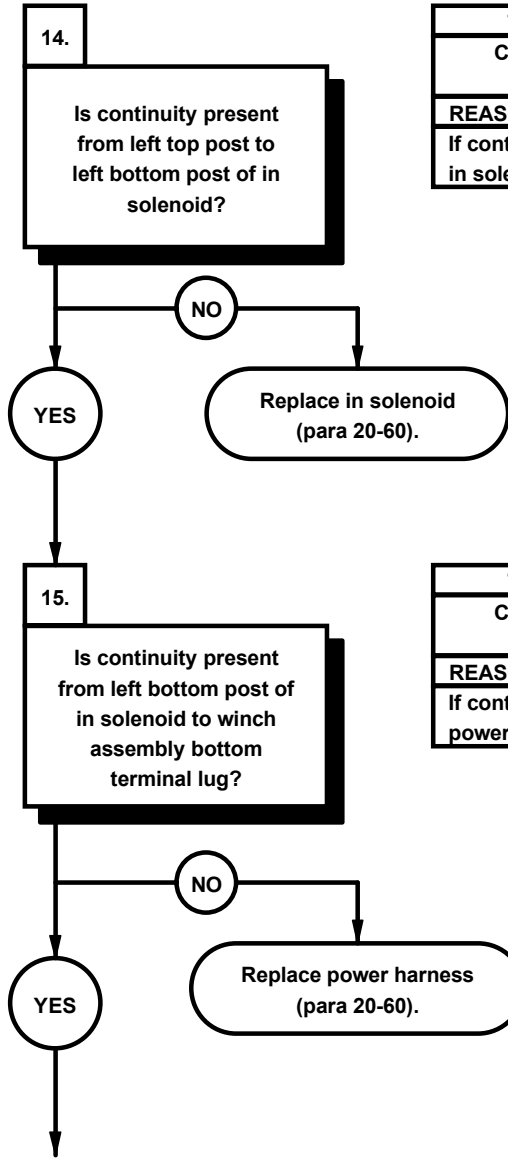

TEST OPTIONS
Continuity Test or STE/ICE-R #91
REASON FOR QUESTION
If continuity is not present, in solenoid is faulty.

TEST OPTIONS
Continuity Test or STE/ICE-R #91
REASON FOR QUESTION
If continuity is not present, power harness is faulty.

CONTINUITY TEST

- (1) Set multimeter to ohms.
- (2) Connect positive (+) probe of multimeter to left top post of in solenoid.
- (3) Connect negative (-) probe of multimeter to left bottom post of in solenoid and note reading on multimeter.
- (4) If continuity is not present, replace in solenoid (para 20-60).

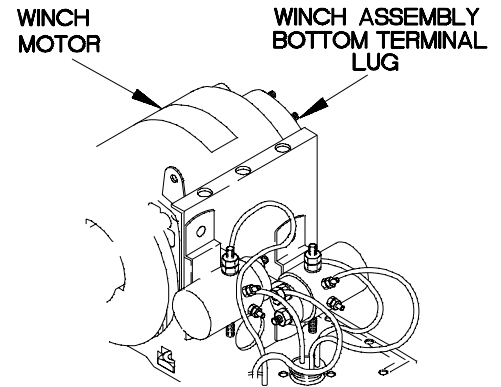

CONTINUITY TEST

- (1) Set multimeter to ohms.
- (2) Connect positive (+) probe of multimeter to left bottom post of in solenoid.
- (3) Connect negative (-) probe of multimeter to winch assembly bottom terminal lug and note reading on multimeter.
- (4) If continuity is not present, replace power harness (para 20-60).

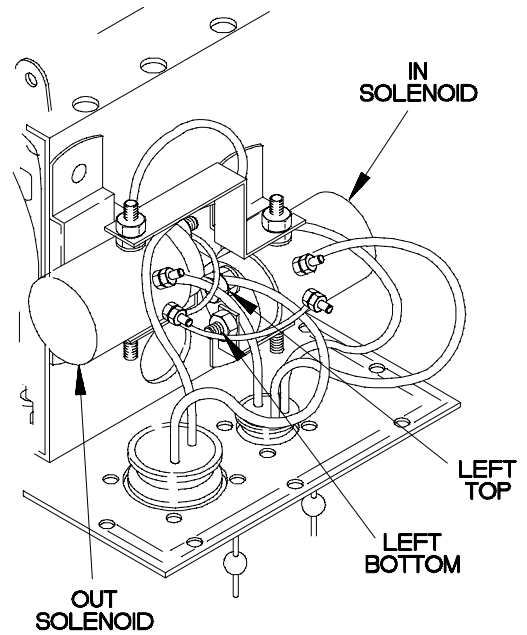

X2x25031

x19. LIGHT MATERIAL HANDLING CRANE (LMHC) DOES NOT OPERATE (CONT)

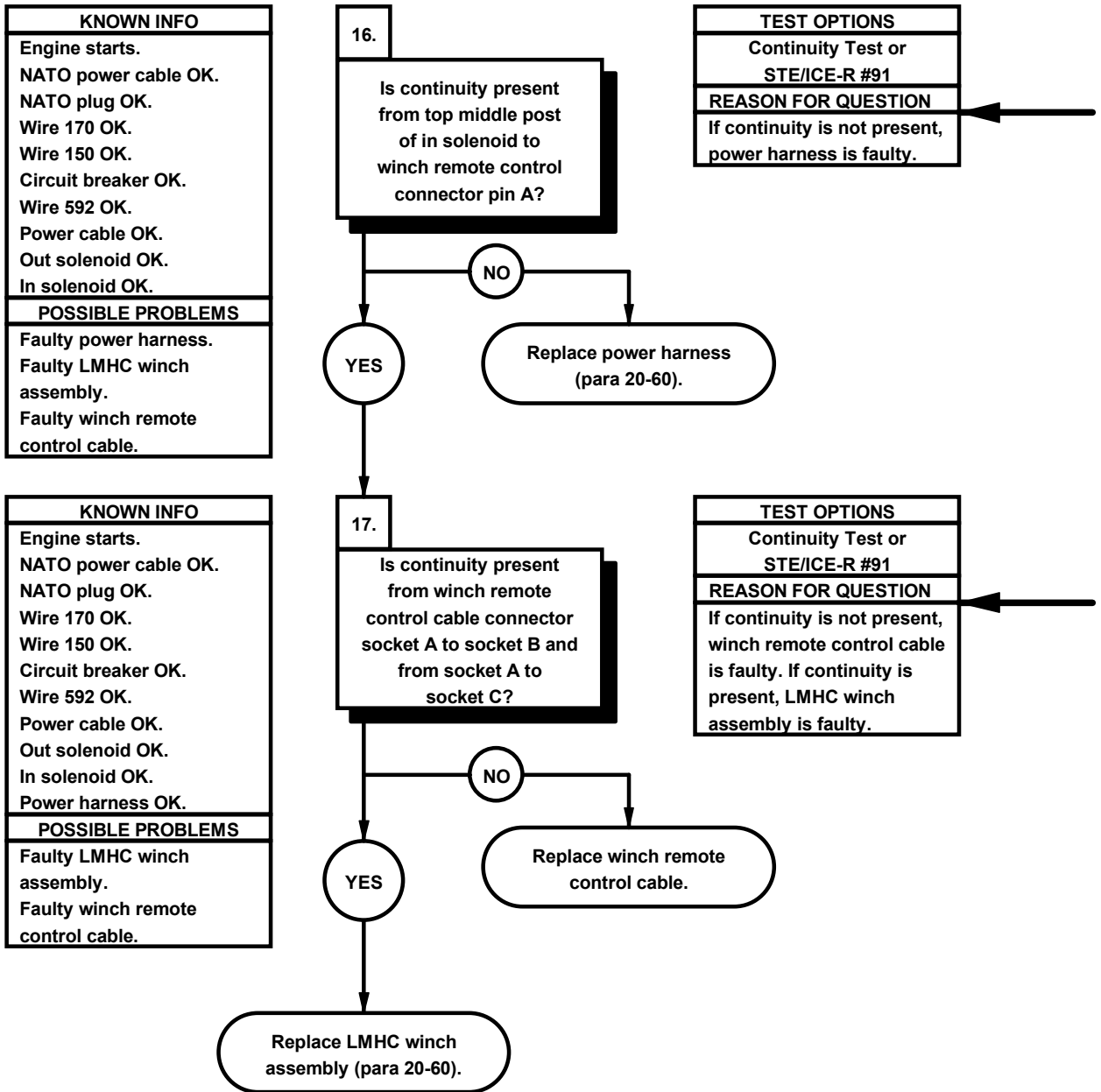

CONTINUITY TEST
(1) Disconnect winch remote control cable from winch remote control connector.
(2) Set multimeter to ohms.
(3) Connect positive (+) probe of multimeter to top middle post of in solenoid.
(4) Connect negative (-) probe of multimeter to winch remote control connector pin A and note reading on multimeter.
(5) If continuity is not present, replace power harness (para 20-60).

CONTINUITY TEST
(1) Set multimeter to ohms.
(2) Connect positive (+) probe of multimeter to winch remote control cable connector socket A.
(3) Connect negative (-) probe of multimeter to winch remote control cable connector socket B.
(4) Position winch remote control switch to OUT and note reading on multimeter.
(5) Connect positive (+) probe of multimeter to winch remote control cable connector socket A.
(6) Connect negative (-) probe of multimeter to winch remote control cable connector socket C.
(7) Position winch remote control switch to in and note reading on multimeter.
(8) If continuity is not present, replace winch remote control cable.
(9) If continuity is present, replace LMHC winch assembly (para 20-60).
(10) Connect LMHC control power cable to LMHC winch assembly power connector.
(11) Connect winch remote control cable to winch remote control connector.
(12) Install cover on base plate with 18 screws.

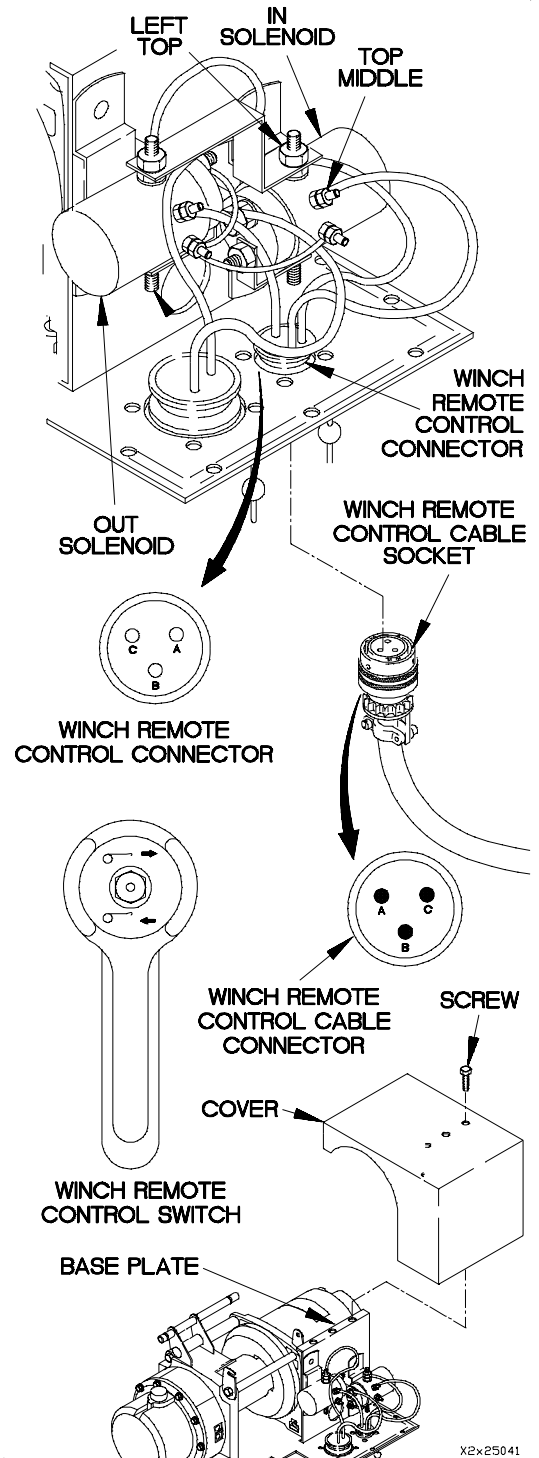

X2x25041

x20. LIGHT MATERIAL HANDLING CRANE (LMHC) HOIST IN DOES NOT OPERATE	
INITIAL SETUP	
Equipment Conditions Engine shut down (TM 9-2320-366-10-1).	Tools and Special Tools Tool Kit, Genl Mech (Item 46, Appendix C) STE/ICE-R (Item 41, Appendix C) Multimeter, Digital (Item 22, Appendix C)
Personnel Required (2)	References TM 9-4910-571-12&P

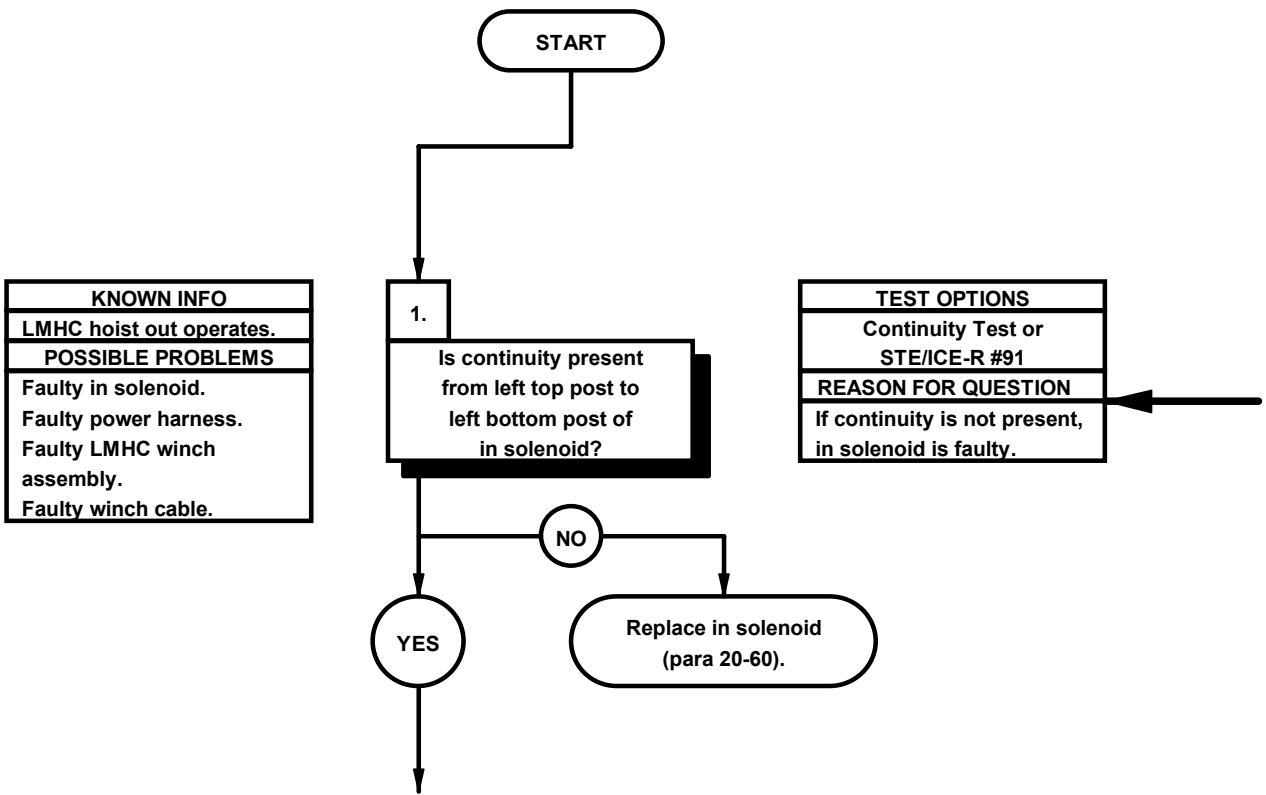

CONTINUITY TEST

- (1) Remove 18 screws and cover from base plate.
- (2) Set multimeter to ohms.
- (3) Connect positive (+) probe of multimeter to left top post of in solenoid.
- (4) Connect negative (-) probe of multimeter to left bottom post of in solenoid and note reading on multimeter.
- (5) If continuity is not present, replace in solenoid (para 20-60).

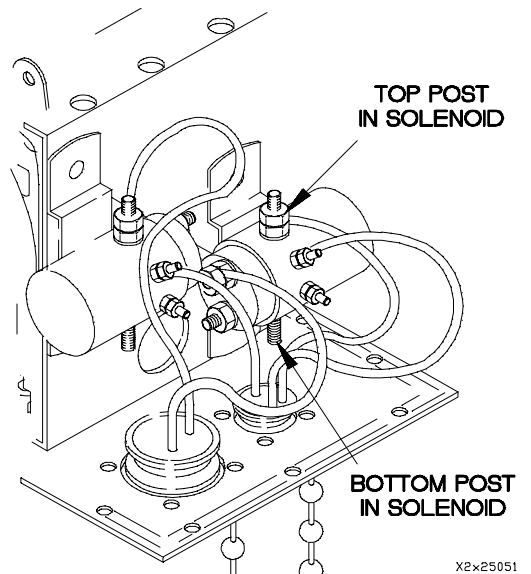
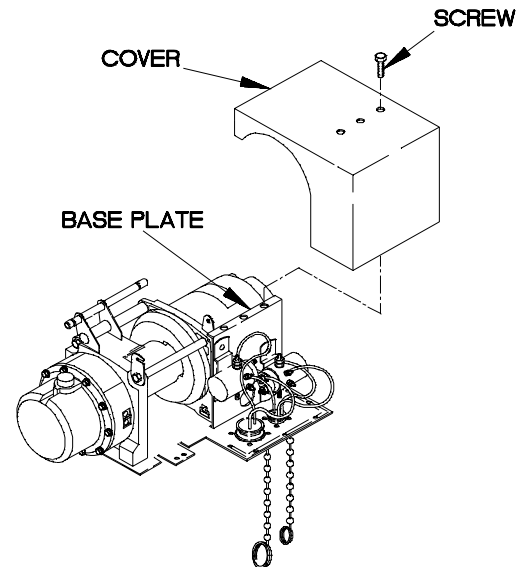

X2x25051

x20. LIGHT MATERIAL HANDLING CRANE (LMHC) HOIST IN DOES NOT OPERATE (CONT)

KNOWN INFO
LMHC hoist out operates. In solenoid OK.
POSSIBLE PROBLEMS
Faulty power harness. Faulty LMHC winch assembly. Faulty winch cable.

2.
Is continuity present from middle top post of in solenoid to LMHC remote control connector pin C?

TEST OPTIONS
Continuity Test or STE/ICE-R #91
REASON FOR QUESTION
If continuity is not present, power harness is faulty.

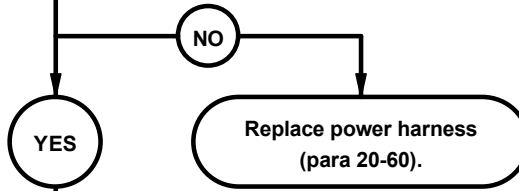

KNOWN INFO
LMHC hoist out operates. In solenoid OK. Power harness OK.
POSSIBLE PROBLEMS
Faulty LMHC winch assembly. Faulty winch cable.

3.
Is continuity present from winch remote control cable socket A to socket C?

TEST OPTIONS
Continuity Test or STE/ICE-R #91
REASON FOR QUESTION
If continuity is not present, winch remote control cable is faulty. If continuity is present, LMHC winch assembly is faulty.

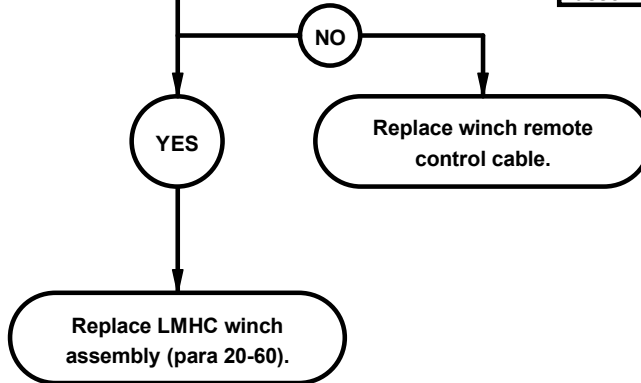

CONTINUITY TEST

- (1) Disconnect winch remote control cable from winch remote control connector.
- (2) Set multimeter to ohms.
- (3) Connect positive (+) probe of multimeter to left middle post of in solenoid.
- (4) Connect negative (-) probe of multimeter to winch remote control connector pin C and note reading on multimeter.
- (5) If continuity is not present, replace power harness (para 20-60).

CONTINUITY TEST

- (1) Set multimeter to ohms.
- (2) Connect positive (+) probe of multimeter to winch remote control cable socket A.
- (3) Connect negative (-) probe of multimeter to winch remote control cable socket C.
- (4) Position winch remote control switch to in and note reading on multimeter.
- (5) If continuity is not present, replace winch remote control cable.
- (6) If continuity is present, replace LMHC winch assembly (para 20-60).
- (7) Connect winch remote control cable to winch remote control connector.
- (8) Install cover on base plate with 18 screws.

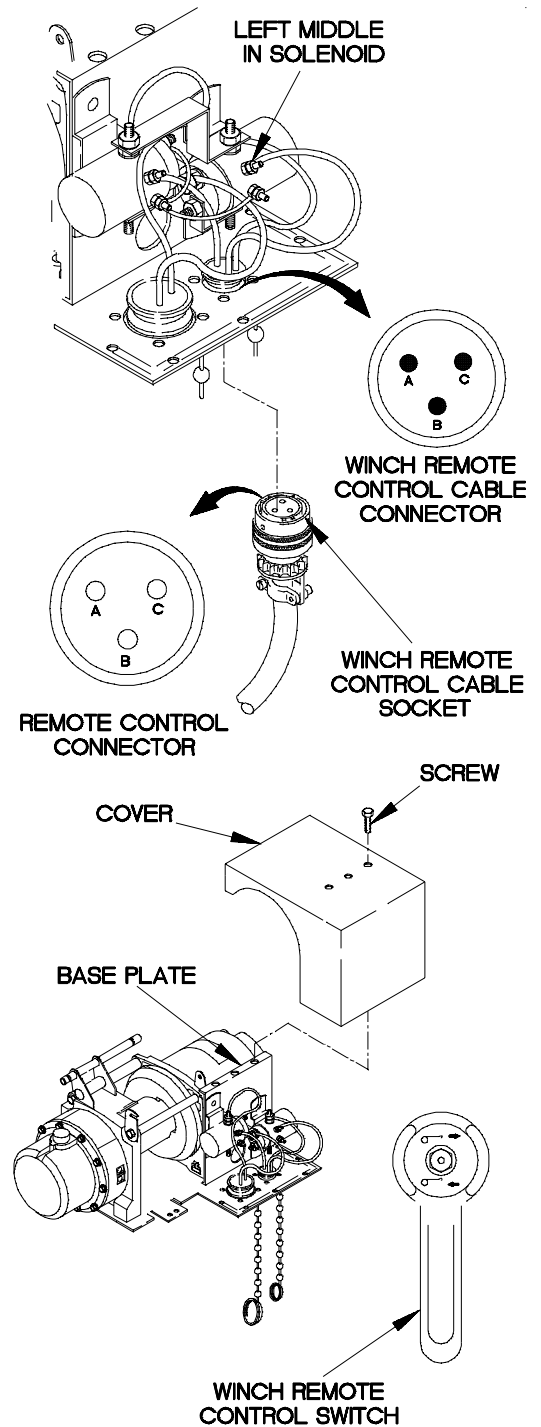

X2x25061

x21. LIGHT MATERIAL HANDLING CRANE (LMHC) HOIST OUT DOES NOT OPERATE	
INITIAL SETUP	
Equipment Conditions Engine shut down (TM 9-2320-366-10-1).	Tools and Special Tools Tool Kit, Genl Mech (Item 46, Appendix C) STE/ICE-R (Item 41, Appendix C) Multimeter, Digital (Item 22, Appendix C)
Personnel Required (2)	References TM 9-4910-571-12&P

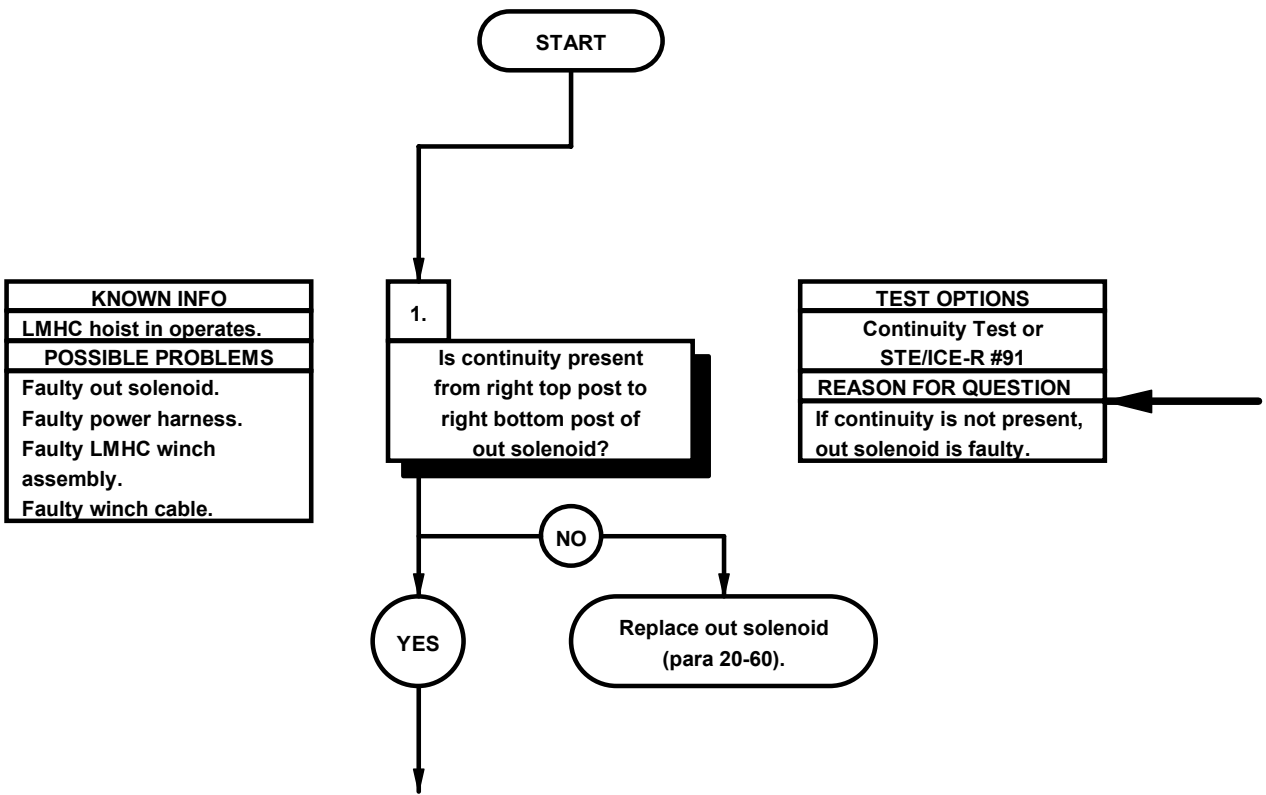

- | CONTINUITY TEST | |
|------------------------|---|
| (1) | Remove 18 screws and cover from base plate. |
| (2) | Set multimeter to ohms. |
| (3) | Connect positive (+) probe of multimeter to right top post of out solenoid. |
| (4) | Connect negative (-) probe of multimeter to right bottom post of out solenoid and note reading on multimeter. |
| (5) | If continuity is not present, replace out solenoid (para 20-60). |

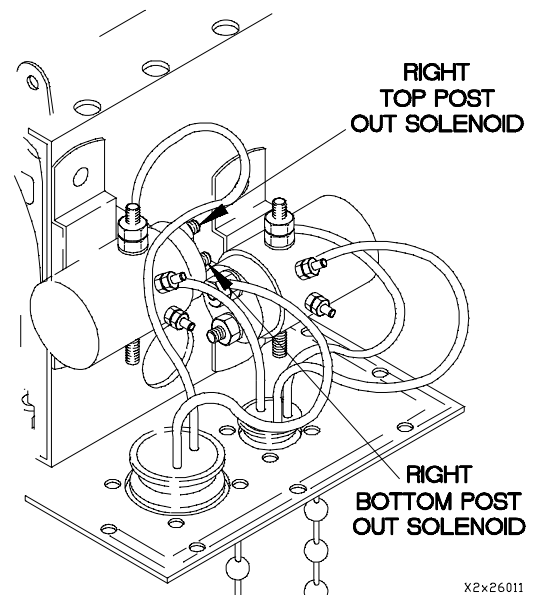
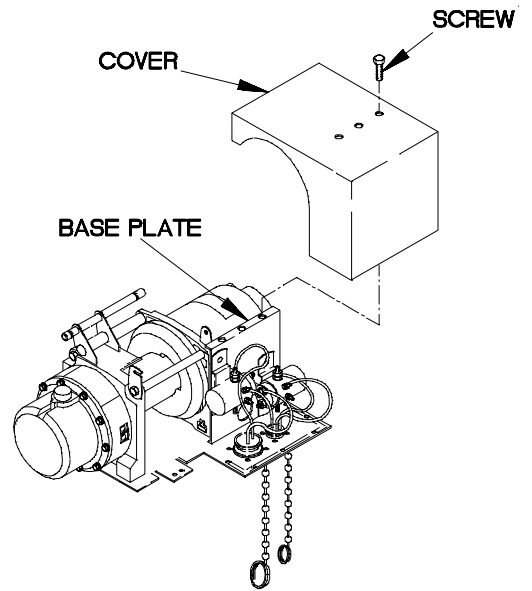

X2x26011

x21. LIGHT MATERIAL HANDLING CRANE (LMHC) HOIST OUT DOES NOT OPERATE (CONT)

KNOWN INFO
LMHC hoist in operates. Out solenoid OK.
POSSIBLE PROBLEMS
Faulty power harness. Faulty LMHC winch assembly. Faulty winch cable.

2.
Is continuity present from middle top post of out solenoid to LMHC remote control connector pin B?

TEST OPTIONS
Continuity Test or STE/ICE-R #91
REASON FOR QUESTION
If continuity is not present, power harness is faulty.

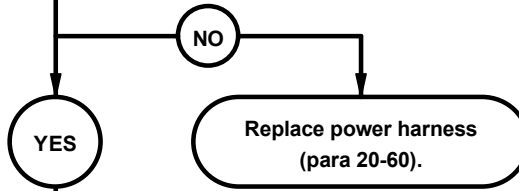

KNOWN INFO
LMHC hoist in operates. Out solenoid OK. Power harness OK.
POSSIBLE PROBLEMS
Faulty LMHC winch assembly. Faulty winch cable.

3.
Is continuity present from winch remote control cable socket A to socket B?

TEST OPTIONS
Continuity Test or STE/ICE-R #91
REASON FOR QUESTION
If continuity is not present, winch remote control cable is faulty. If continuity is present, LMHC winch assembly is faulty.

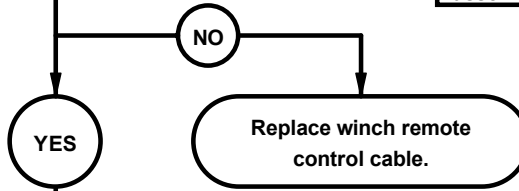

Replace LMHC winch assembly (para 20-60).

CONTINUITY TEST

- (1) Disconnect winch remote control cable from winch remote control connector.
- (2) Set multimeter to ohms.
- (3) Connect positive (+) probe of multimeter to right middle post of out solenoid.
- (4) Connect negative (-) probe of multimeter to winch remote control connector pin B and note reading on multimeter.
- (5) If continuity is not present, replace power harness (para 20-60).

CONTINUITY TEST

- (1) Set multimeter to ohms.
- (2) Connect positive (+) probe of multimeter to winch remote control cable socket A.
- (3) Connect negative (-) probe of multimeter to winch remote control cable socket B.
- (4) Position winch remote control switch to out and note reading on multimeter.
- (5) If continuity is not present, replace winch remote control cable.
- (6) If continuity is present, replace LMHC winch assembly (para 20-60).
- (7) Connect winch remote control cable to winch remote control connector.
- (8) Install cover on base plate with 18 screws.

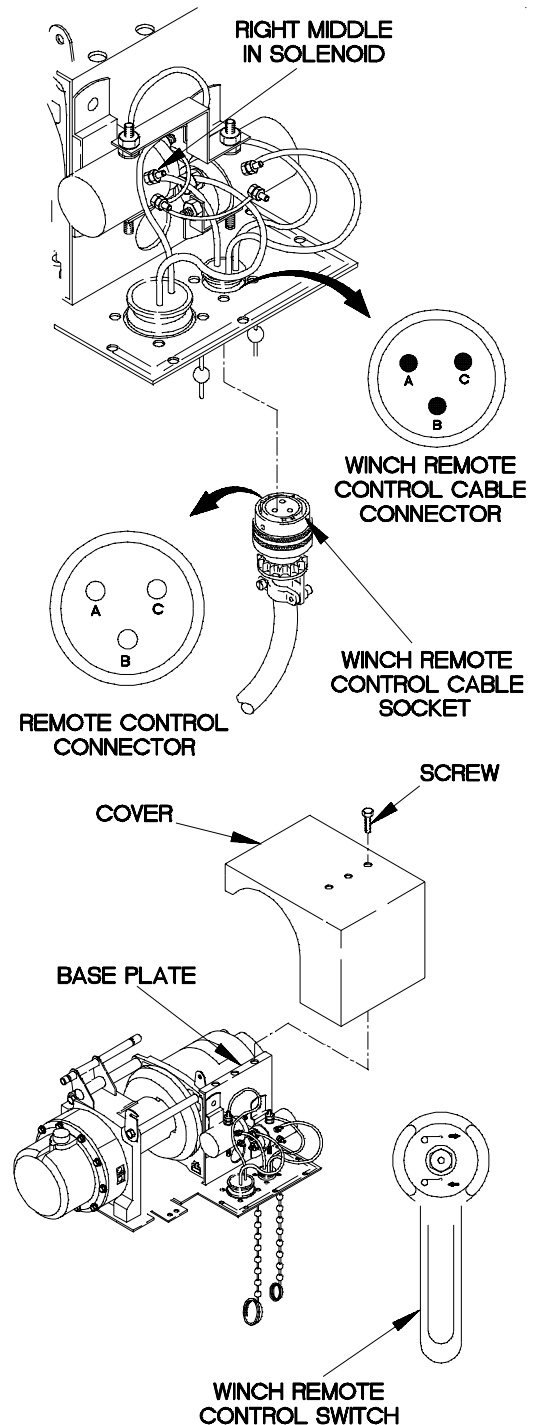

X2x26031

2-35. M1084/M1086 MATERIAL HANDLING CRANE (MHC) HYDRAULIC TROUBLESHOOTING

This paragraph covers M1084/M1086 Material Handling Crane (MHC) Hydraulic Troubleshooting. The M1084/ M1086 Material Handling Crane (MHC) Hydraulic Fault Index, Table 2-63, lists faults for the M1084/M1086 MHC Hydraulic system.

Table 2-63. M1084/M1086 Material Handling Crane (MHC) Hydraulic Fault Index

Fault No.	Description	Page
y1.	M1084/M1086 Material Handling Crane (MHC) Hand Pump Does Not Work	2-2410

y1. M1084/M1086 MATERIAL HANDLING CRANE (MHC) HAND PUMP DOES NOT WORK	
INITIAL SETUP	
Equipment Conditions Engine shut down (TM 9-2320-366-10-1).	Tools and Special Tools Tool Kit, Genl Mech (Item 46, Appendix C) Pan, Drain (Item 24, Appendix C) Goggles, Industrial (Item 15, Appendix C)
	Materials/Parts Rag, Wiping (Item 50, Appendix D)

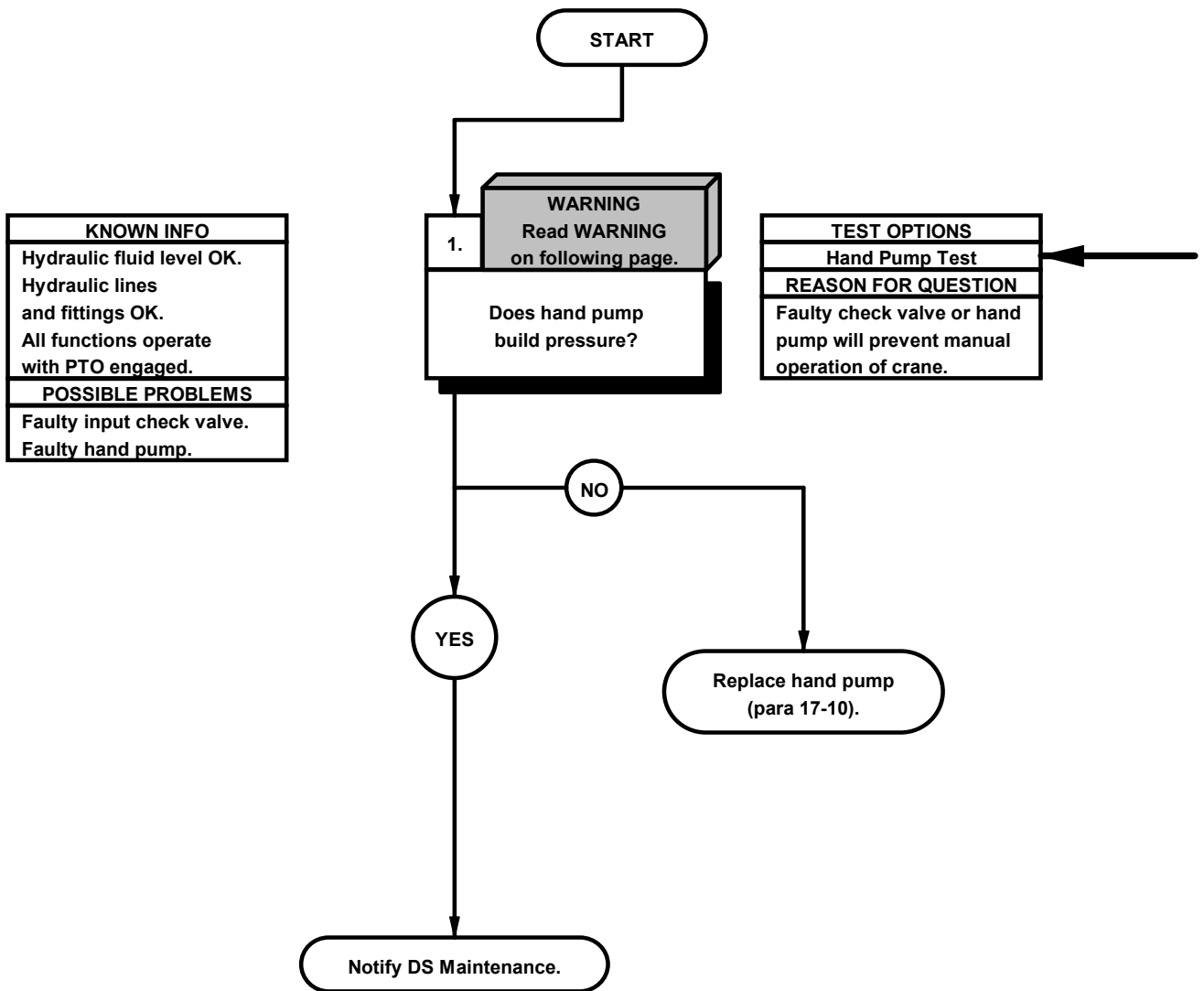

WARNING

- Drop hydraulic pressure to zero before disconnecting any hydraulic line. Failure to comply may result in injury to personnel.
- Wear approved eye protection when performing pressure checks. Failure to comply may result in oil getting into eyes. If oil contacts eyes, seek medical attention immediately.
- Fuel and oil are slippery and can cause falls. Wipe up spilled fuel or oil with rags. Failure to comply may result in injury to personnel.

HAND PUMP TEST

- (1) Disconnect hand pump delivery line from elbow at hand pump.
- (2) Place drain pan under port at pump to catch hydraulic fluid.
- (3) Pump hand pump (TM 9-2320-366-10-1).
- (4) Check if hydraulic fluid pumps out of port with each stroke.
- (5) If little or no fluid pumps out, replace hand pump (para 17-10).
- (6) Connect delivery line to elbow at hand pump.
- (7) Remove drain pan.

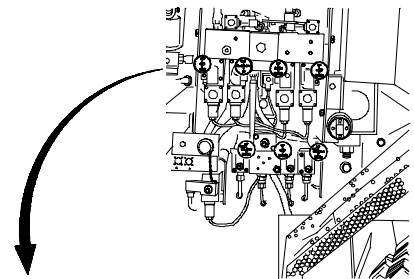
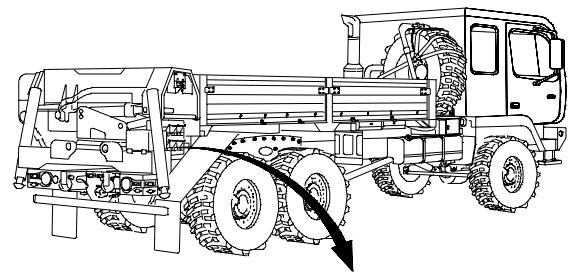

HAND PUMP

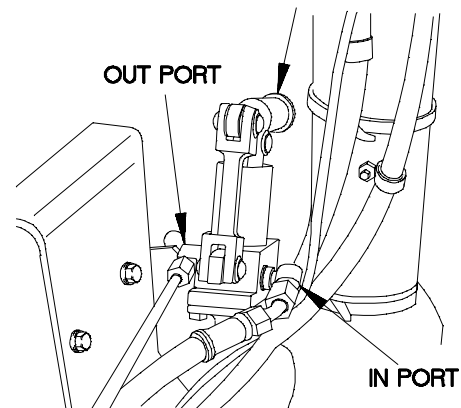

42y0101a

2-36. CAB AND SPARE TIRE RETAINER TROUBLESHOOTING

This paragraph covers Cab and Spare Tire Retainer Troubleshooting. The Cab and Spare Tire Retainer Fault Index, Table 2-64, lists faults for the cab and spare tire retainer of the vehicle.

Table 2-64. Cab and Spare Tire Retainer Fault Index

Fault No.	Description	Page
z1.	Cab Does Not Raise	2-2414
z2.	Cab Does Not Lower	2-2414.8
z3.	Spare Tire Retainer Does Not Raise	2-2416
z4.	Spare Tire Retainer Does Not Lower	2-2416.6

z1. CAB DOES NOT RAISE

INITIAL SETUP

Equipment Condition

Engine shut down (TM 9-2320-366-10-1).
Air tanks drained (TM 9-232-366-10-1).

Personnel Required

(2)

Material/Parts

Rag, Wiping (Item 50, Appendix D)
Filter Element, Fluid (Item 21.1, Appendix G)

Tools and Special Tools

Tool Kit, Genl Mech (Item 46, Appendix C)
STE/ICE-R (Item 41, Appendix C)
Pan, Drain (Item 24, Appendix C)
Goggles, Industrial (Item 15, Appendix C)
Transmitter, Pressure (Item 1, Appendix J)
Wrench, Torque, 0-200 lb-in. (Item 59, Appendix C)
Key, Socket Head Screw (Item 38.1, Appendix B)

References

TM 9-4910-571-12&P

NOTE

On vehicles S/N 0001 through 7558, the hydraulic manifold, P/N 12420621, was not originally equipped with an orifice filter. Orifice filter, P/N 117073098-000, however, may have been installed during previous maintenance to the hydraulic manifold.

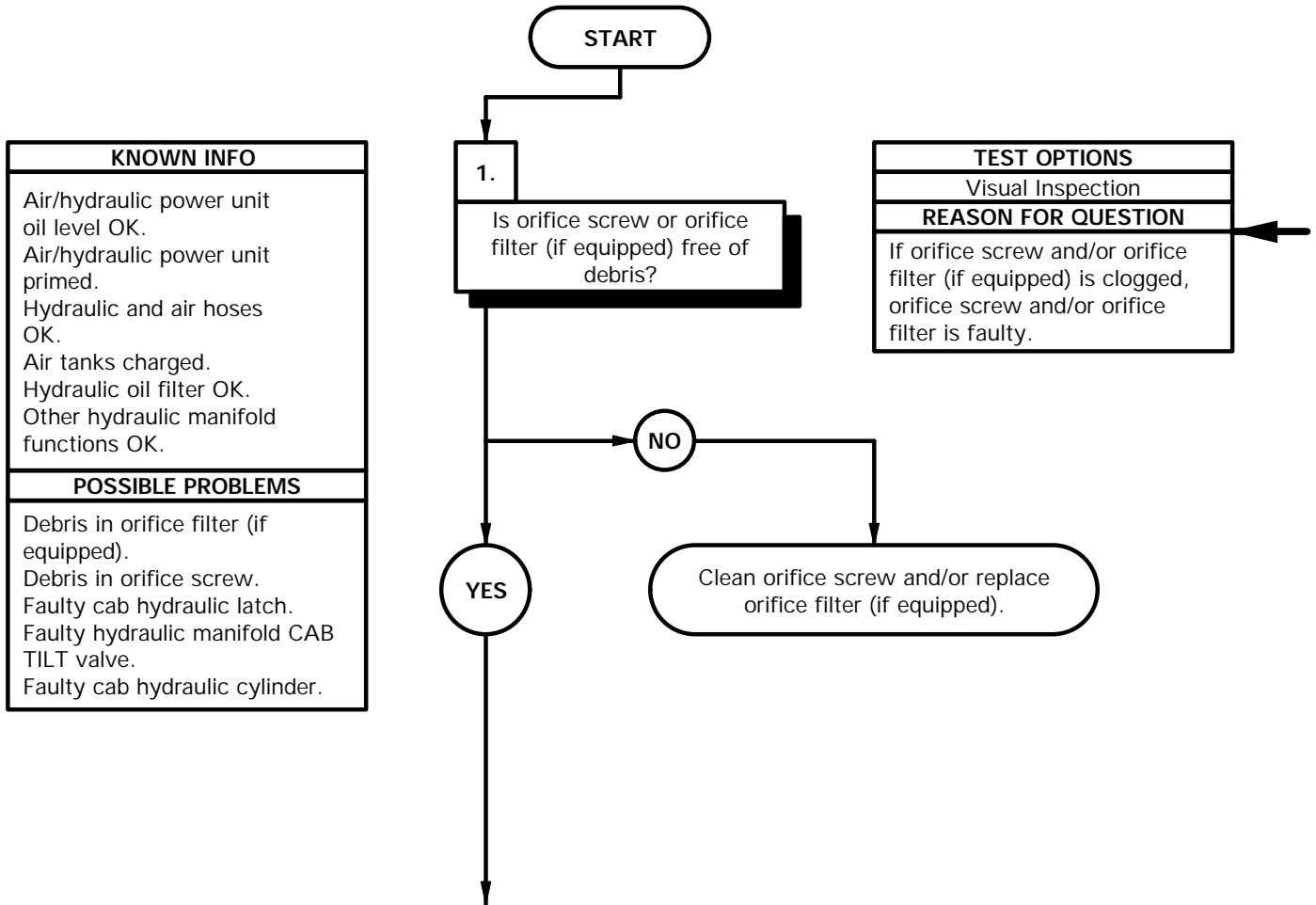

WARNING

Drop hydraulic pressure to zero before disconnecting any hydraulic hoses. Failure to comply may result in injury to personnel.

Hydraulic fluid (MIL-H-5606) is TOXIC. Wear protective goggles and gloves; use only in well ventilated area; avoid contact with skin, eyes, and clothes. Skin and clothing that come into contact with hydraulic fluid should be washed immediately. Saturated clothing should be removed immediately. Failure to comply may result in injury to personnel.

Compressed air used for cleaning purposes will not exceed 30 psi (270 kPa). Use only with effective chip guarding and personal protective equipment (goggles, shields, gloves, etc.). Failure to comply may result in injury to personnel.

NOTE

Perform steps (1) through (12) on hydraulic manifolds installed on vehicles S/N 001 through 7558.

- (1) Remove pin from hydraulic manifold cover and lower cover.
- (2) Cycle FUNCTION SELECT knob through all settings.
- (3) Cycle CAB TILT knob through both selector settings.
- (4) Remove screw, knob, and CAB TILT valve from hydraulic manifold.
- (5) Remove orifice filter (if equipped) from hydraulic manifold.
- (6) If debris is present in orifice filter, replace orifice filter.
- (7) Remove orifice screw from hydraulic manifold.
- (8) If debris is present in orifice screw, clean orifice screw with compressed air.

NOTE

If no orifice filter was previously installed, orifice filter will be installed at this time.

- (9) Install orifice screw and orifice filter in hydraulic manifold.
- (10) Position CAB TILT valve and knob on hydraulic manifold with screw.
- (11) Tighten screw to 5-15 lb-in. (1-2 N-m).
- (12) Close hydraulic manifold cover and install pin.

Cont. on page 2-2414.3.

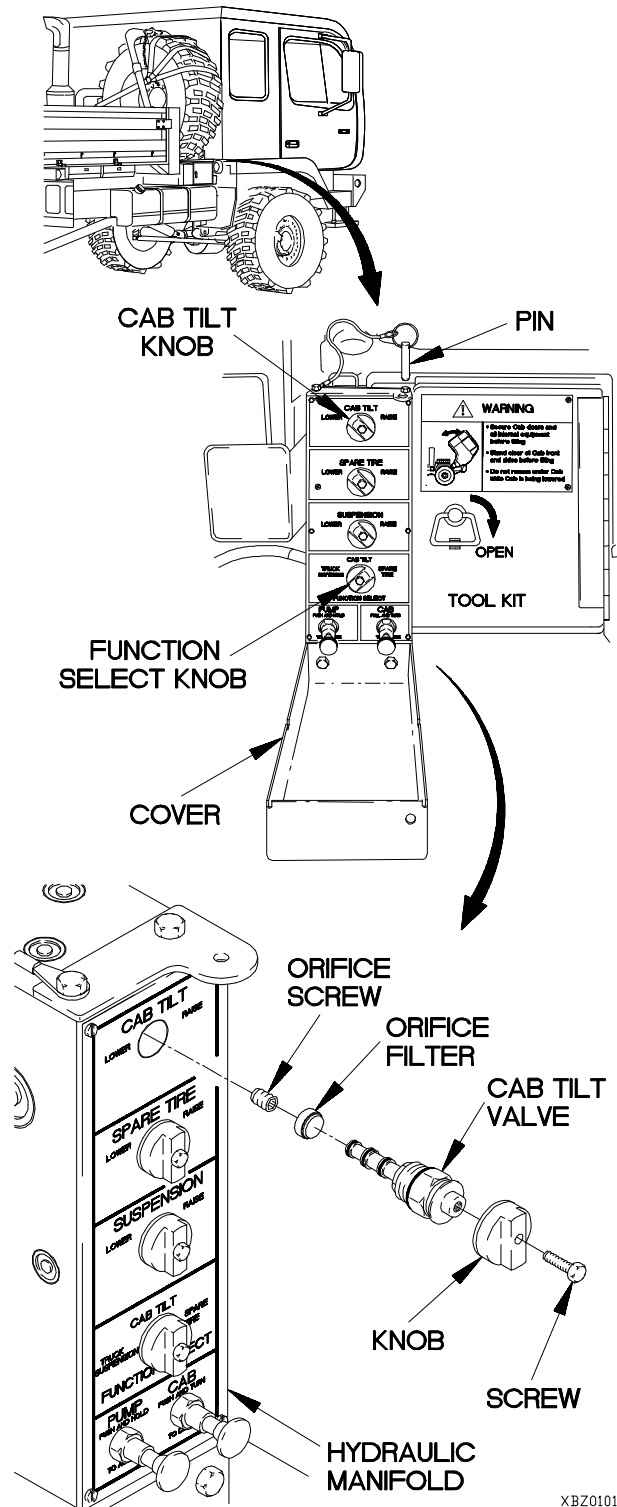

XBZ0101B

Cont. from page 2-2414.1.

WARNING

Drop hydraulic pressure to zero before disconnecting any hydraulic hoses. Failure to comply may result in injury to personnel.

Hydraulic fluid (MIL-H-5606) is TOXIC. Wear protective goggles and gloves; use only in well ventilated area; avoid contact with skin, eyes, and clothes. Skin and clothing that come into contact with hydraulic fluid should be washed immediately. Saturated clothing should be removed immediately. Failure to comply may result in injury to personnel.

Compressed air used for cleaning purposes will not exceed 30 psi (270 kPa). Use only with effective chip guarding and personal protective equipment (goggles, shields, gloves, etc.). Failure to comply may result in injury to personnel.

NOTE

Perform steps (13) through (25) on hydraulic manifolds installed on vehicles S/N 7559 and higher or on vehicles where hydraulic manifolds have two valves on left side.

- (13) Remove pin from hydraulic manifold cover and lower cover.
- (14) Cycle FUNCTION SELECT knob through all settings.
- (15) Cycle CAB TILT knob through both selector settings.
- (16) Remove nut, knob, spring, spacer, retainer ring, and rubber sleeve from CAB TILT valve.
- (17) Remove CAB TILT valve from hydraulic manifold.
- (18) Remove orifice filter from hydraulic manifold.
- (19) If debris is present in orifice filter, replace orifice filter.
- (20) Remove orifice screw from hydraulic manifold.
- (21) If debris is present in orifice screw, clean orifice screw with compressed air.
- (22) Install orifice screw and orifice filter in hydraulic manifold.
- (23) Install CAB TILT valve in hydraulic manifold.
- (24) Install rubber sleeve, retainer ring, spacer, spring, knob, and nut on hydraulic manifold.
- (25) Close hydraulic manifold cover and install pin.

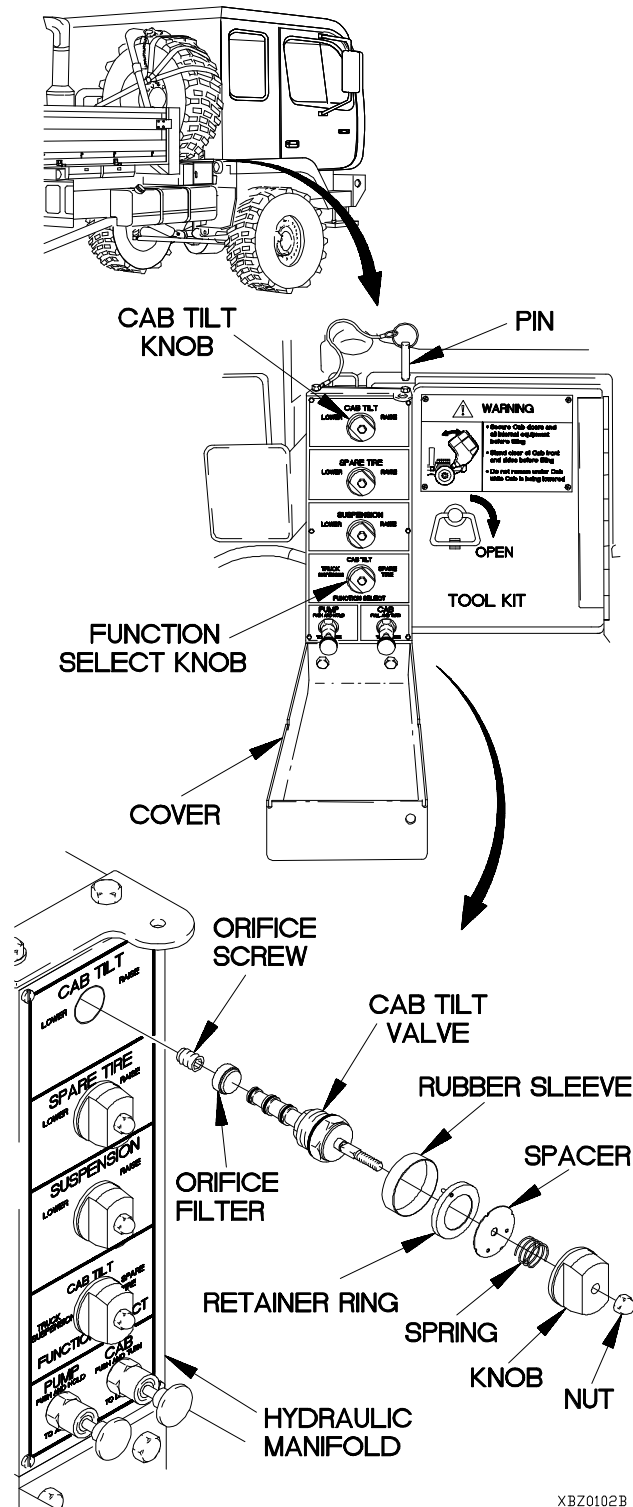

XBZ0102B

z1. CAB DOES NOT RAISE (CONT)

KNOWN INFO
Air/hydraulic power unit oil level OK. Air/hydraulic power unit primed. Hydraulic and air hoses OK. Air tanks charged. Hydraulic oil filter OK. Other hydraulic manifold functions OK. Orifice filter OK. Orifice screw OK.
POSSIBLE PROBLEMS
Faulty cab hydraulic latch. Faulty hydraulic manifold CAB TILT valve. Faulty cab hydraulic cylinder.

2.
Is cab hydraulic latch adjusted properly?

TEST OPTIONS
Visual Inspection
REASON FOR QUESTION
If cab hydraulic latch is not adjusted properly, cab hydraulic latch is faulty.

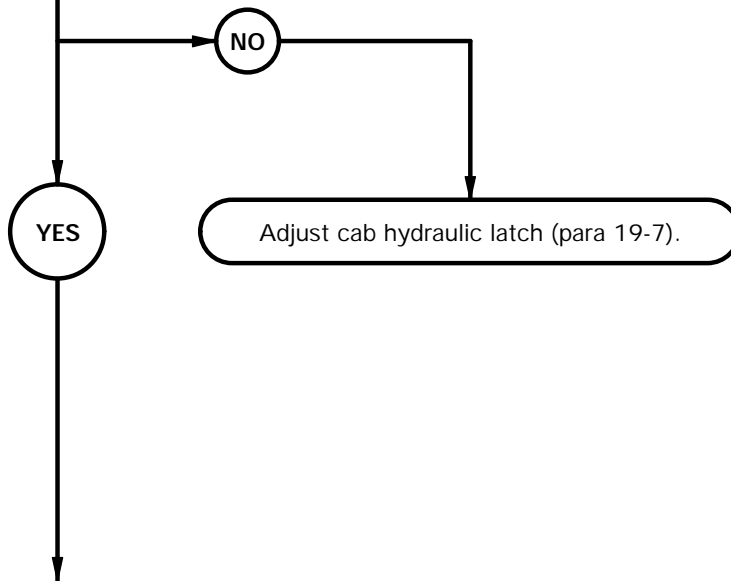

- (1) Start engine and charge air tanks (TM 9-2320-366-10-1).
- (2) Position CAB TILT knob to RAISE.
- (3) Position FUNCTION SELECT knob to CAB TILT.
- (4) Check to see if cab hydraulic latch indicator button is in the unlatched position.
- (5) If cab hydraulic latch indicator button does not unlatch, adjust cab hydraulic latch (para 19-7).

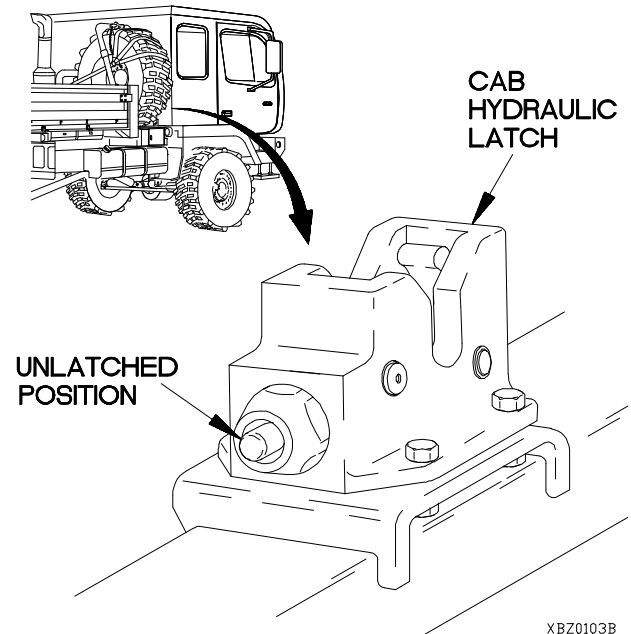
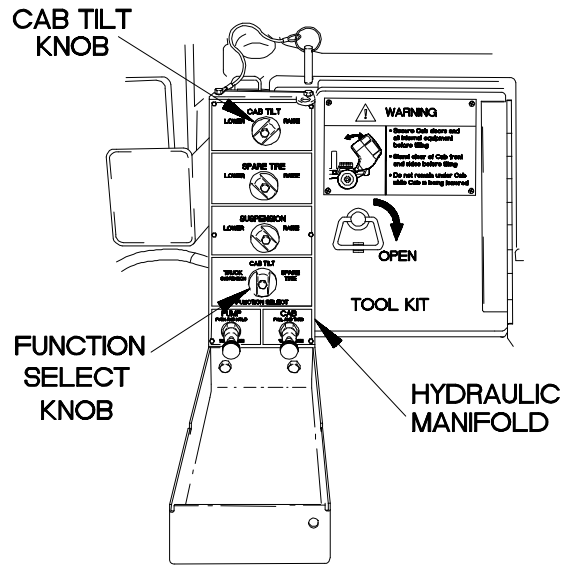

XBZ0103B

z1. CAB DOES NOT RAISE (CONT)

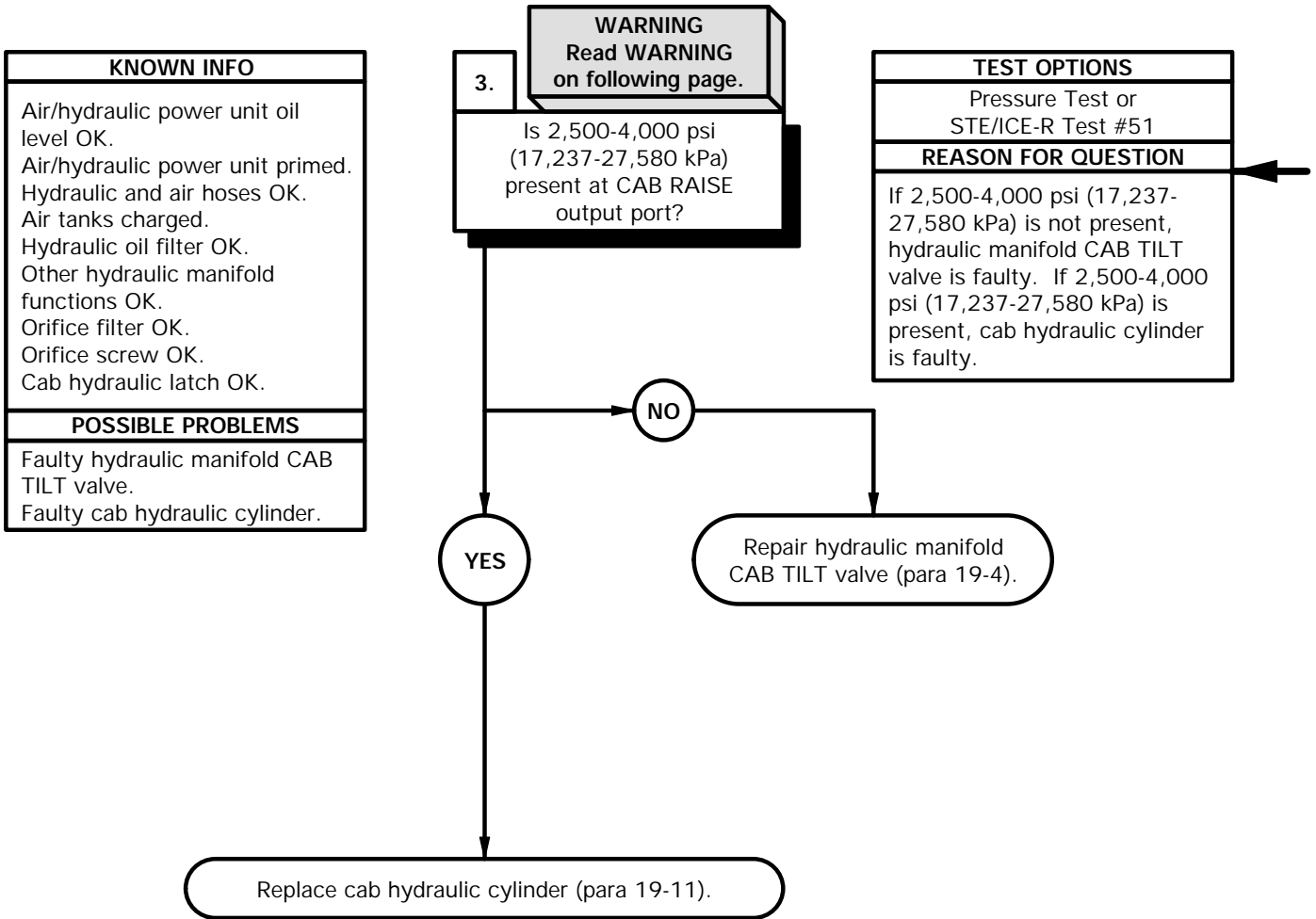

WARNING

Drop hydraulic pressure to zero before disconnecting any hydraulic hoses. Failure to comply may result in injury to personnel.

Hydraulic fluid (MIL-H-5606) is TOXIC. Wear protective goggles and gloves; use only in well ventilated area; avoid contact with skin, eyes, and clothes. Skin and clothing that come into contact with hydraulic fluid should be washed immediately. Saturated clothing should be removed immediately. Failure to comply may result in injury to personnel.

PRESSURE TEST

- (1) Position drain pan under cab hydraulic cylinder.
- (2) Disconnect CAB RAISE pressure hose from cab hydraulic cylinder output port.
- (3) Connect STE/ICE-R to CAB RAISE pressure hose.
- (4) Start engine and charge air tanks (TM 9-2320-366-10-1).
- (5) Position CAB TILT knob to RAISE.
- (6) Position FUNCTION SELECT knob to CAB TILT.
- (7) Push and hold PUMP plunger button and perform STE-ICE-R Test #51 (TM 9-4910-571-12&P).
- (8) If pressure is not 2,500-4,000 psi (17,237-27,580 kPa), repair hydraulic manifold CAB TILT valve (para 19-4).
- (9) If pressure is 2,500-4,000 psi (17,237-27,580 kPa), replace cab hydraulic cylinder (para 19-11).
- (10) Drain air tanks (TM 9-2320-366-10-1).
- (11) Disconnect STE/ICE-R from pressure hose.
- (12) Connect pressure hose to cab hydraulic cylinder output port.

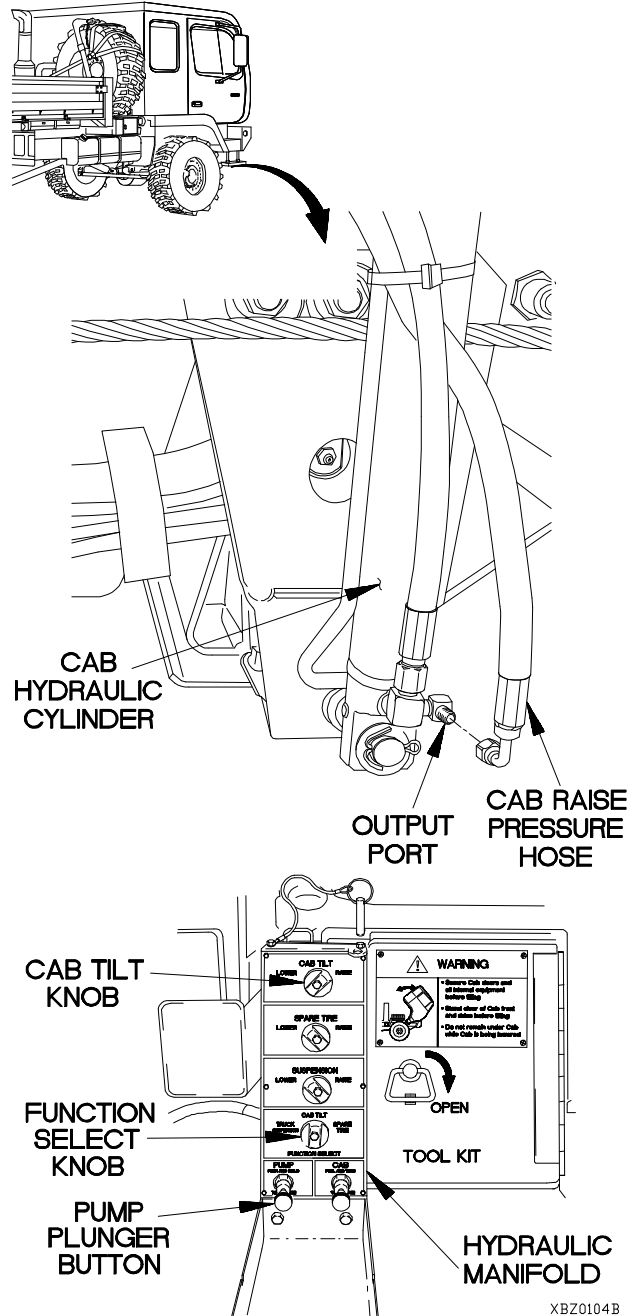

z2. CAB DOES NOT LOWER

INITIAL SETUP

Equipment Condition

Engine shut down (TM 9-2320-366-10-1).
Air tanks drained (TM 9-232-366-10-1).

Personnel Required

(2)

Material/Parts

Rag, Wiping (Item 50, Appendix D)
Filter Element, Fluid (Item 21.1, Appendix G)

Tools and Special Tools

Tool Kit, Genl Mech (Item 46, Appendix C)
STE/ICE-R (Item 41, Appendix C)
Pan, Drain (Item 24, Appendix C)
Goggles, Industrial (Item 15, Appendix C)
Transmitter, Pressure (Item 1, Appendix J)
Wrench, Torque, 0-200 lb-in. (Item 59, Appendix C)
Key, Socket Head Screw (Item 38.1, Appendix B)

References

TM 9-4910-571-12&P

NOTE

On vehicles S/N 0001 through 7558, the hydraulic manifold, P/N 12420621, was not originally equipped with an orifice filter. Orifice filter, P/N 117073098-000, however, may have been installed during previous maintenance to the hydraulic manifold.

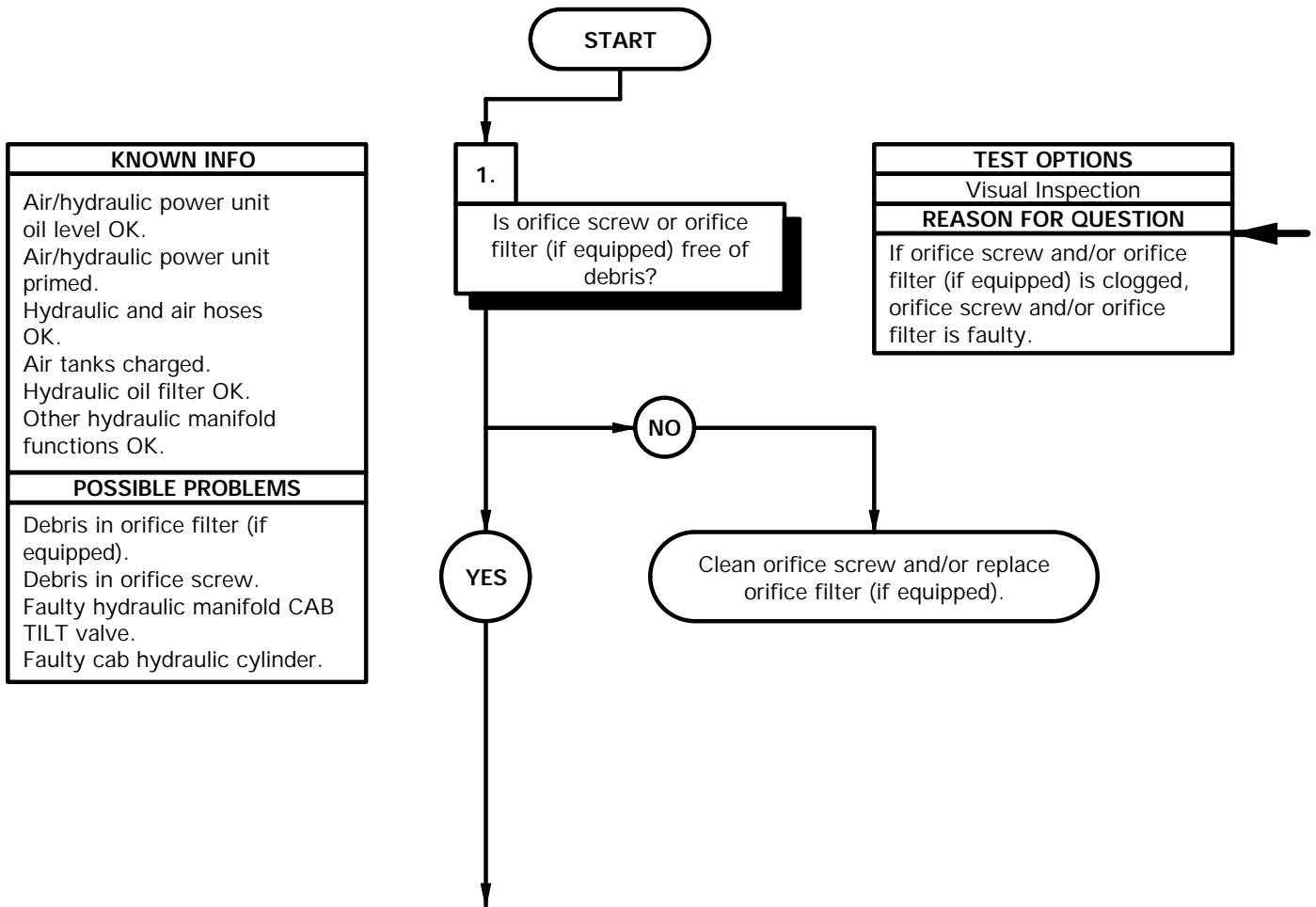

WARNING

Drop hydraulic pressure to zero before disconnecting any hydraulic hoses. Failure to comply may result in injury to personnel.

Hydraulic fluid (MIL-H-5606) is TOXIC. Wear protective goggles and gloves; use only in well ventilated area; avoid contact with skin, eyes, and clothes. Skin and clothing that come into contact with hydraulic fluid should be washed immediately. Saturated clothing should be removed immediately. Failure to comply may result in injury to personnel.

Compressed air used for cleaning purposes will not exceed 30 psi (270 kPa). Use only with effective chip guarding and personal protective equipment (goggles, shields, gloves, etc.). Failure to comply may result in injury to personnel.

NOTE

Perform steps (1) through (12) on hydraulic manifolds installed on vehicles S/N 001 through 7558.

- (1) Remove pin from hydraulic manifold cover and lower cover.
- (2) Cycle FUNCTION SELECT knob through all settings.
- (3) Cycle CAB TILT knob through both selector settings.
- (4) Remove screw, knob, and CAB TILT valve from hydraulic manifold.
- (5) Remove orifice filter (if equipped) from hydraulic manifold.
- (6) If debris is present in orifice filter, replace orifice filter.
- (7) Remove orifice screw from hydraulic manifold.
- (8) If debris is present in orifice screw, clean orifice screw with compressed air.

NOTE

If no orifice filter was previously installed, orifice filter will be installed at this time.

- (9) Install orifice screw and orifice filter in hydraulic manifold.
- (10) Position CAB TILT valve and knob on hydraulic manifold with screw.
- (11) Tighten screw to 5-15 lb-in. (1-2 N-m).
- (12) Close hydraulic manifold cover and install pin.

Cont. on page 2-2414.11.

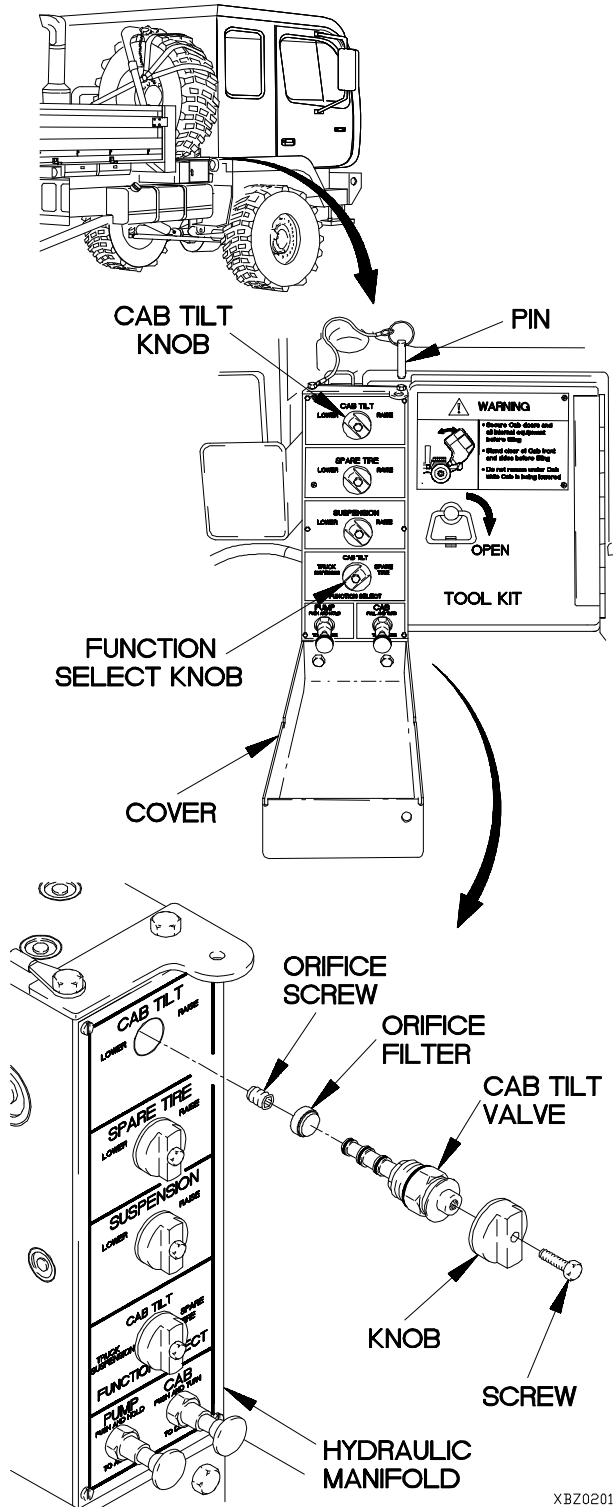

XBZ0201B

Cont. from page 2-2414.9.

WARNING

Drop hydraulic pressure to zero before disconnecting any hydraulic hoses. Failure to comply may result in injury to personnel.

Hydraulic fluid (MIL-H-5606) is TOXIC. Wear protective goggles and gloves; use only in well ventilated area; avoid contact with skin, eyes, and clothes. Skin and clothing that come into contact with hydraulic fluid should be washed immediately. Saturated clothing should be removed immediately. Failure to comply may result in injury to personnel.

Compressed air used for cleaning purposes will not exceed 30 psi (270 kPa). Use only with effective chip guarding and personal protective equipment (goggles, shields, gloves, etc.). Failure to comply may result in injury to personnel.

NOTE

Perform steps (13) through (25) on hydraulic manifolds installed on vehicles S/N 7559 and higher or on vehicles where hydraulic manifolds have two valves on left side.

- (13) Remove pin from hydraulic manifold cover and lower cover.
- (14) Cycle FUNCTION SELECT knob through all settings.
- (15) Cycle CAB TILT knob through both selector settings.
- (16) Remove nut, knob, spring, spacer, retainer ring, and rubber sleeve from CAB TILT valve.
- (17) Remove CAB TILT valve from hydraulic manifold.
- (18) Remove orifice filter from hydraulic manifold.
- (19) If debris is present in orifice filter, replace orifice filter.
- (20) Remove orifice screw from hydraulic manifold.
- (21) If debris is present in orifice screw, clean orifice screw with compressed air.
- (22) Install orifice screw and orifice filter in hydraulic manifold.
- (23) Install CAB TILT valve in hydraulic manifold.
- (24) Install rubber sleeve, retainer ring, spacer, spring, knob, and nut on hydraulic manifold.
- (25) Close hydraulic manifold cover and install pin.

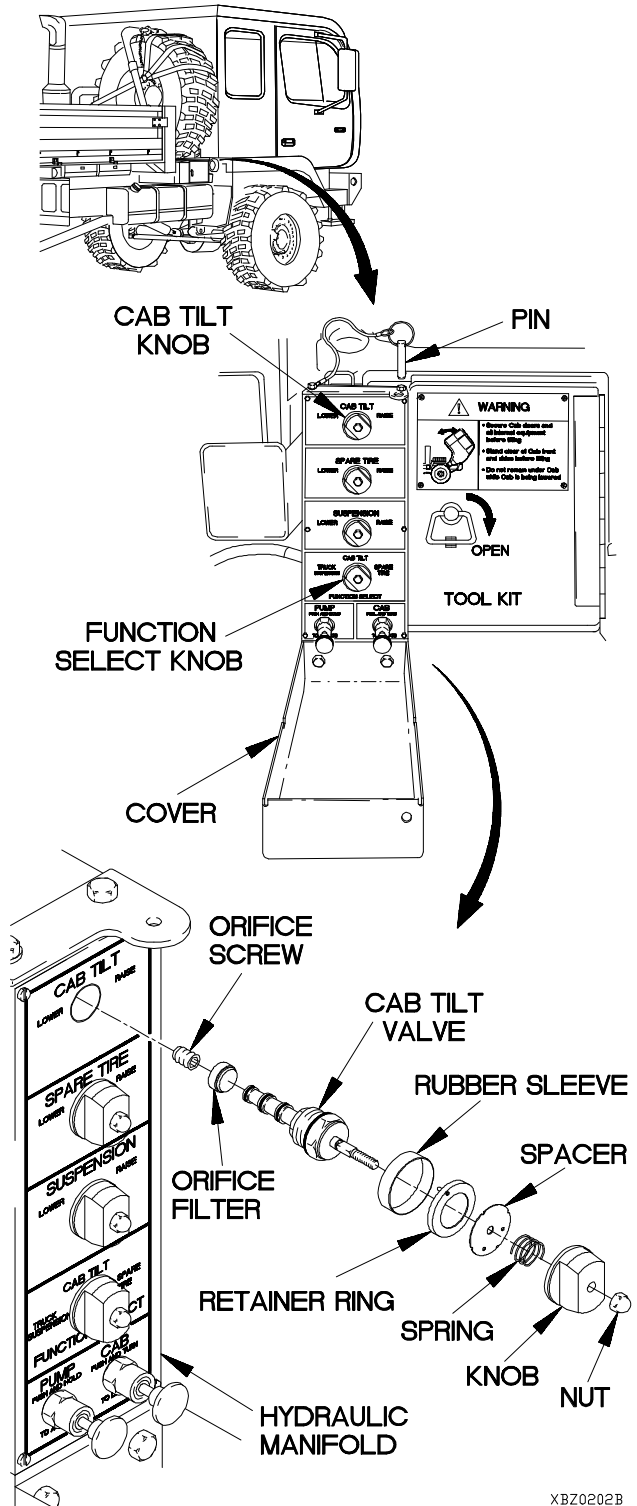

XBZ0202B

z2. CAB DOES NOT LOWER (CONT)

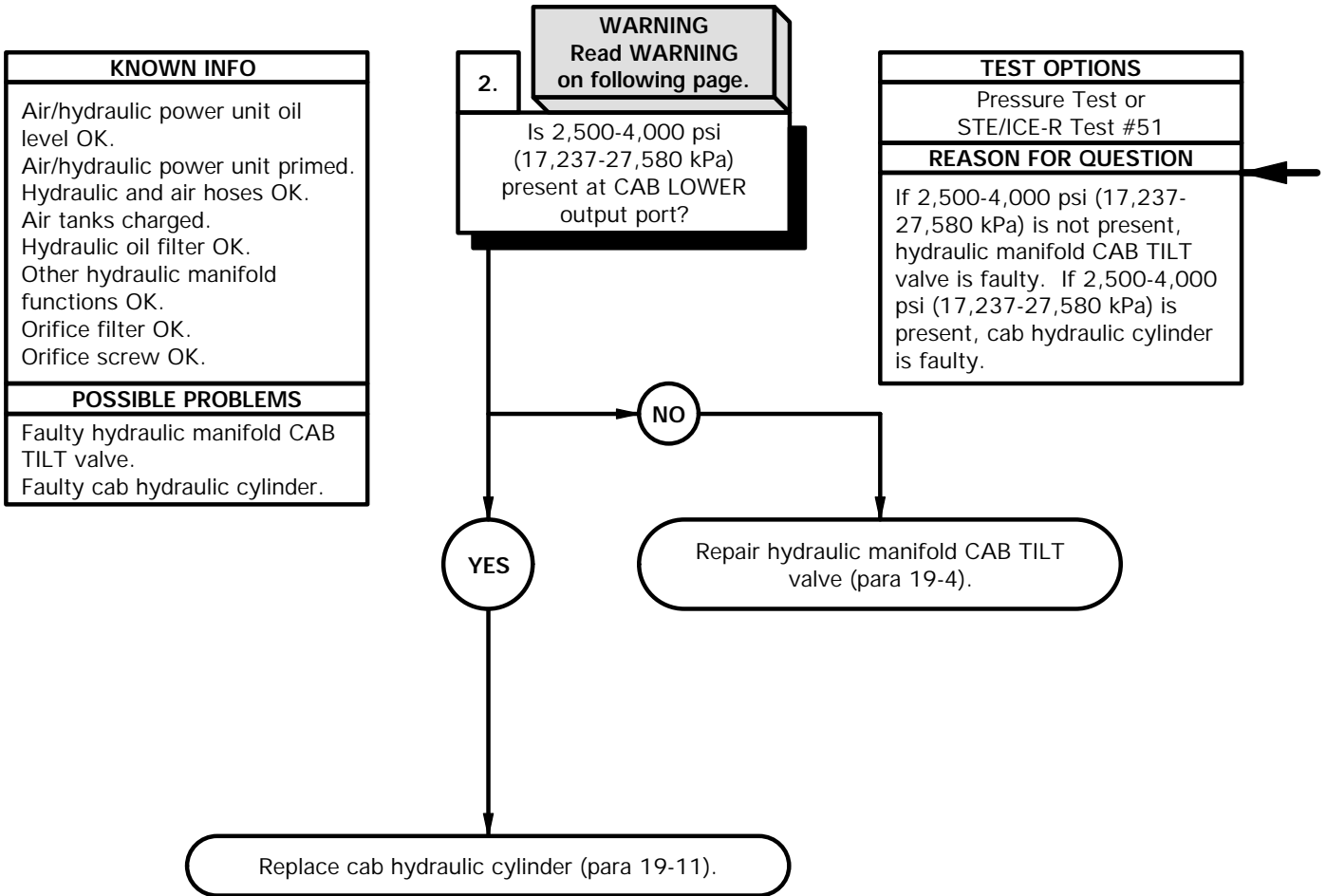

WARNING

Drop hydraulic pressure to zero before disconnecting any hydraulic hoses. Failure to comply may result in injury to personnel.

Hydraulic fluid (MIL-H-5606) is TOXIC. Wear protective goggles and gloves; use only in well ventilated area; avoid contact with skin, eyes, and clothes. Skin and clothing that come into contact with hydraulic fluid should be washed immediately. Saturated clothing should be removed immediately. Failure to comply may result in injury to personnel.

PRESSURE TEST

- (1) Position drain pan under cab hydraulic cylinder.
- (2) Disconnect CAB LOWER pressure hose from cab hydraulic cylinder output port.
- (3) Connect STE/ICE-R to CAB LOWER pressure hose.
- (4) Start engine and charge air tanks (TM 9-2320-366-10-1).
- (5) Position CAB TILT knob to LOWER.
- (6) Position FUNCTION SELECT knob to CAB TILT.
- (7) Push and hold PUMP plunger button and perform STE-ICE-R Test #51 (TM 9-4910-571-12&P).
- (8) If pressure is not 2,500-4,000 psi (17,237-27,580 kPa), repair hydraulic manifold CAB TILT valve (para 19-4).
- (9) If pressure is 2,500-4,000 psi (17,237-27,580 kPa), replace cab hydraulic cylinder (para 19-11).
- (10) Drain air tanks (TM 9-2320-366-10-1).
- (11) Disconnect STE/ICE-R from pressure hose.
- (12) Connect pressure hose to cab hydraulic cylinder output port.

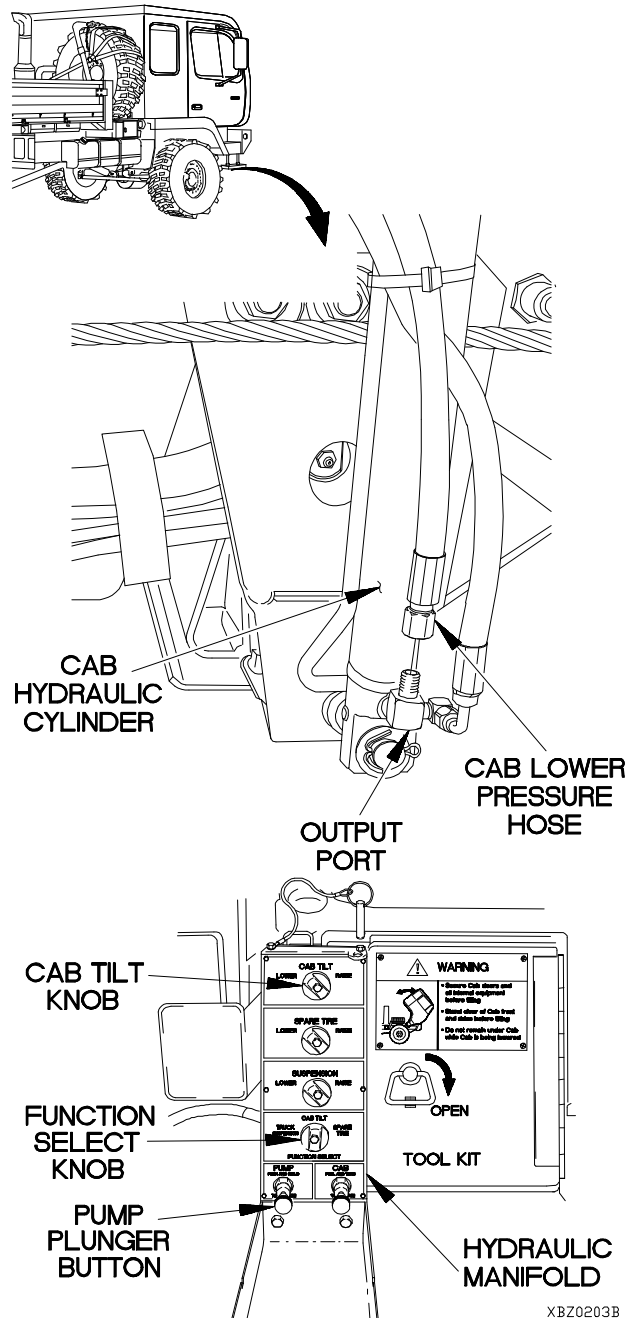

z3. SPARE TIRE RETAINER DOES NOT RAISE

INITIAL SETUP

Equipment Condition

Engine shut down (TM 9-2320-366-10-1).
Air tanks drained (TM 9-232-366-10-1).

Personnel Required

(2)

Material/Parts

Rag, Wiping (Item 50, Appendix D)
Filter, Element, Fluid (Item 21.1, Appendix G)

Tools and Special Tools

Tool Kit, Genl Mech (Item 46, Appendix C)
STE/ICE-R (Item 41, Appendix C)
Pan, Drain (Item 24, Appendix C)
Goggles, Industrial (Item 15, Appendix C)
Transmitter, Pressure (Item 1, Appendix J)
Wrench, Torque, 0-200 lb-in. (Item 59, Appendix C)
Key, Socket Head Screw (Item 38.1, Appendix B)

References

TM 9-4910-571-12&P

NOTE

On vehicles S/N 0001 through 7558, the hydraulic manifold, P/N 12420621, was not originally equipped with an orifice filter. Orifice filter, P/N 117073098-000, however, may have been installed during previous maintenance to the hydraulic manifold.

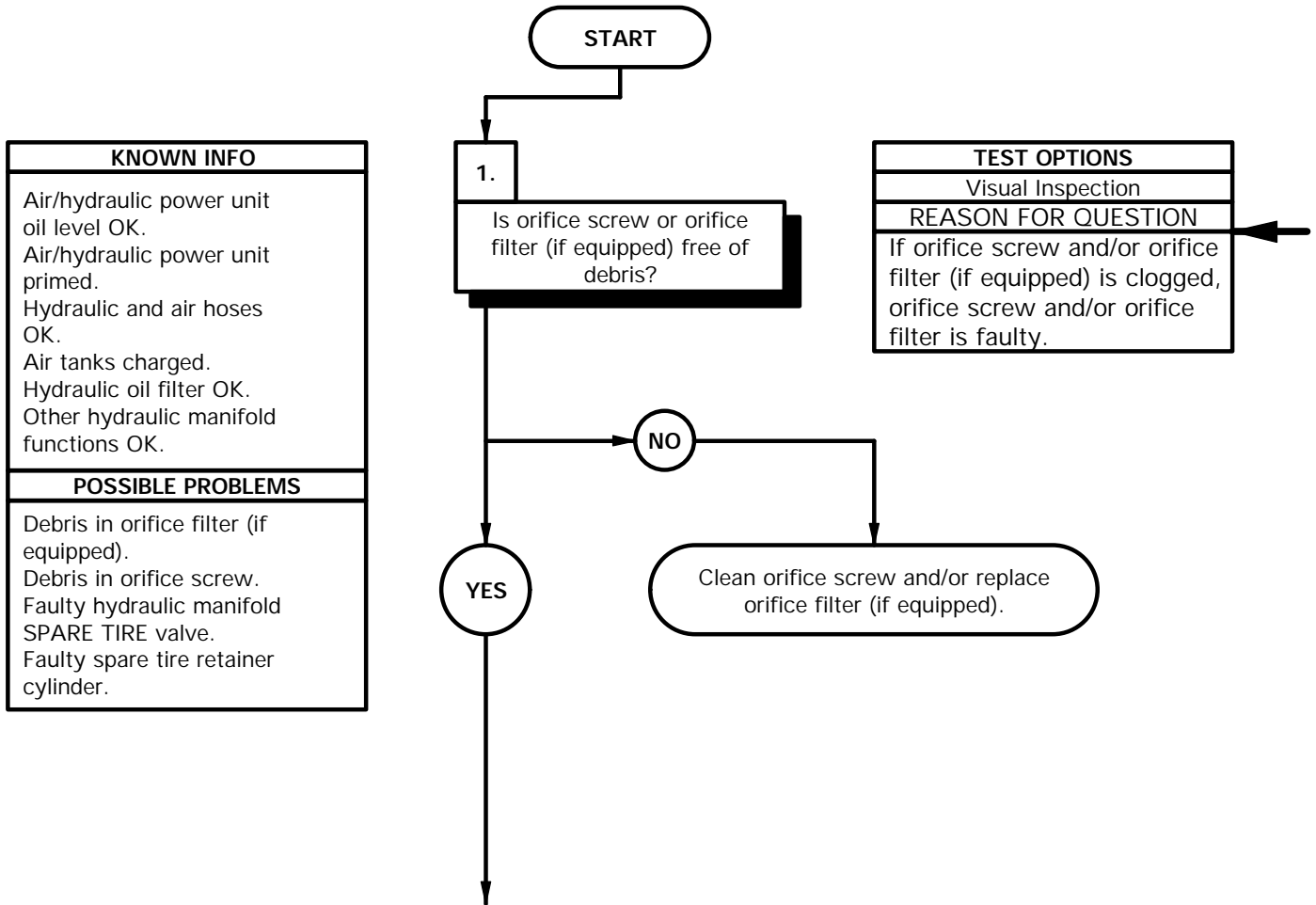

WARNING

Drop hydraulic pressure to zero before disconnecting any hydraulic hoses. Failure to comply may result in injury to personnel.

Hydraulic fluid (MIL-H-5606) is TOXIC. Wear protective goggles and gloves; use only in well ventilated area; avoid contact with skin, eyes, and clothes. Skin and clothing that come into contact with hydraulic fluid should be washed immediately. Saturated clothing should be removed immediately. Failure to comply may result in injury to personnel.

Compressed air used for cleaning purposes will not exceed 30 psi (270 kPa). Use only with effective chip guarding and personal protective equipment (goggles, shields, gloves, etc.). Failure to comply may result in injury to personnel.

NOTE

Perform steps (1) through (12) on hydraulic manifolds installed on vehicles S/N 001 through 7558.

- (1) Remove pin from hydraulic manifold cover and raise cover.
- (2) Cycle FUNCTION SELECT knob through all settings.
- (3) Cycle SPARE TIRE knob through both selector settings.
- (4) Remove screw, knob, and SPARE TIRE valve from hydraulic manifold.
- (5) Remove orifice filter (if equipped) from hydraulic manifold.
- (6) If debris is present in orifice filter, replace orifice filter.
- (7) Remove orifice screw from hydraulic manifold.
- (8) If debris is present in orifice screw, clean orifice screw with compressed air.

NOTE

If no orifice filter was previously installed, orifice filter will be installed at this time.

- (9) Install orifice screw and orifice filter in hydraulic manifold.
- (10) Position SPARE TIRE valve and knob on hydraulic manifold with screw.
- (11) Tighten screw to 5-15 lb-in. (1-2 N-m).
- (12) Close hydraulic manifold cover and install pin.

Cont. on page 2-2416.3.

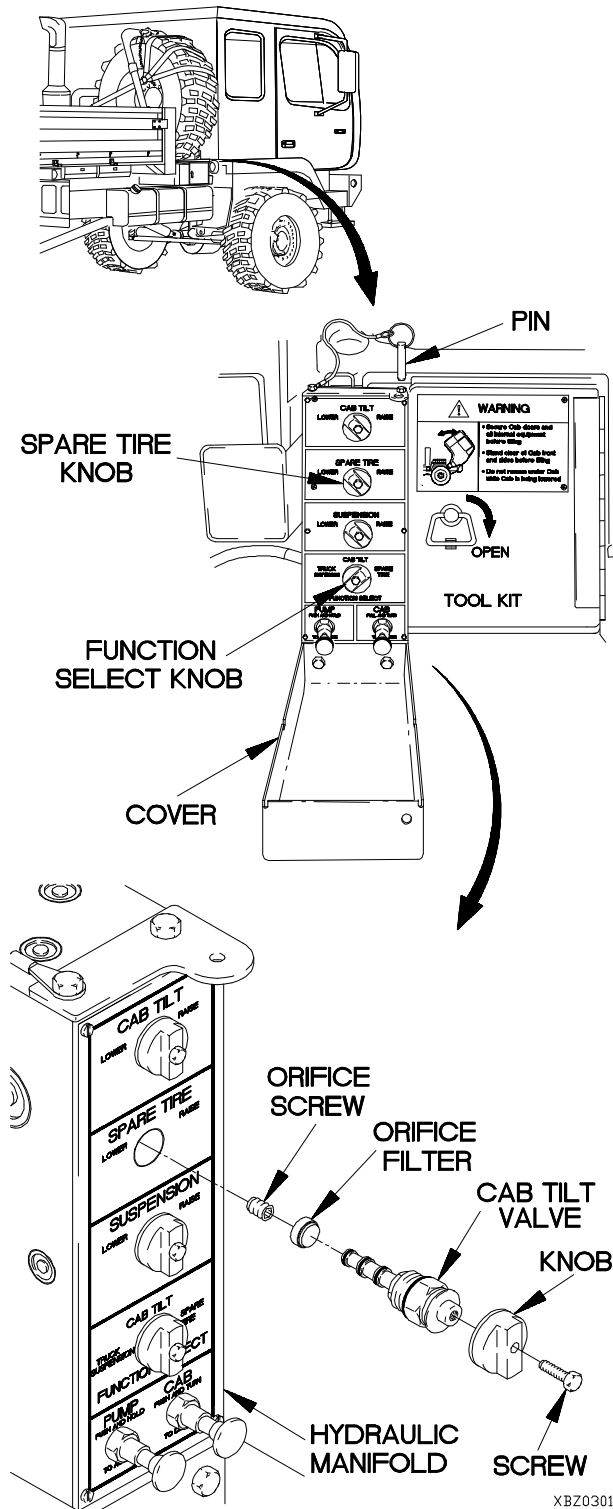

XBZ0301B

Cont. from page 2-2416.1.

WARNING

Drop hydraulic pressure to zero before disconnecting any hydraulic hoses. Failure to comply may result in injury to personnel.

Hydraulic fluid (MIL-H-5606) is TOXIC. Wear protective goggles and gloves; use only in well ventilated area; avoid contact with skin, eyes, and clothes. Skin and clothing that come into contact with hydraulic fluid should be washed immediately. Saturated clothing should be removed immediately. Failure to comply may result in injury to personnel.

Compressed air used for cleaning purposes will not exceed 30 psi (270 kPa). Use only with effective chip guarding and personal protective equipment (goggles, shields, gloves, etc.). Failure to comply may result in injury to personnel.

NOTE

Perform steps (13) through (25) on hydraulic manifolds installed on vehicles S/N 7559 and higher or on vehicles where hydraulic manifolds have two valves on left side.

- (13) Remove pin from hydraulic manifold cover and raise cover.
- (14) Cycle FUNCTION SELECT knob through all settings.
- (15) Cycle SPARE TIRE knob through both selector settings.
- (16) Remove nut, knob, spring, spacer, retainer ring, and rubber sleeve from SPARE TIRE valve.
- (17) Remove SPARE TIRE valve from hydraulic manifold.
- (18) Remove orifice filter from hydraulic manifold.
- (19) If debris is present in orifice filter, replace orifice filter.
- (20) Remove orifice screw from hydraulic manifold.
- (21) If debris is present in orifice screw, clean orifice screw with compressed air.
- (22) Install orifice screw and orifice filter in hydraulic manifold.
- (23) Install SPARE TIRE valve in hydraulic manifold.
- (24) Install rubber sleeve, retainer ring, spacer, spring, knob, and nut on hydraulic manifold.
- (25) Close hydraulic manifold cover and install pin.

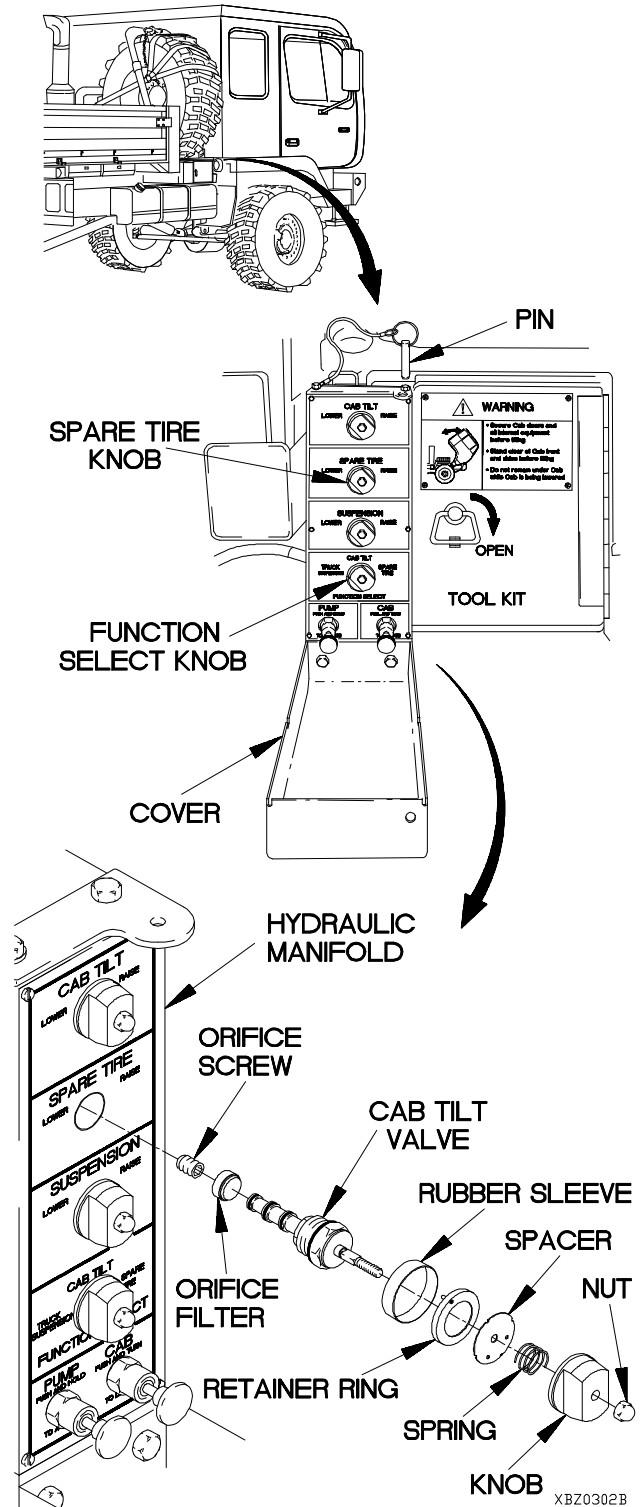

z3. SPARE TIRE RETAINER DOES NOT RAISE (CONT)

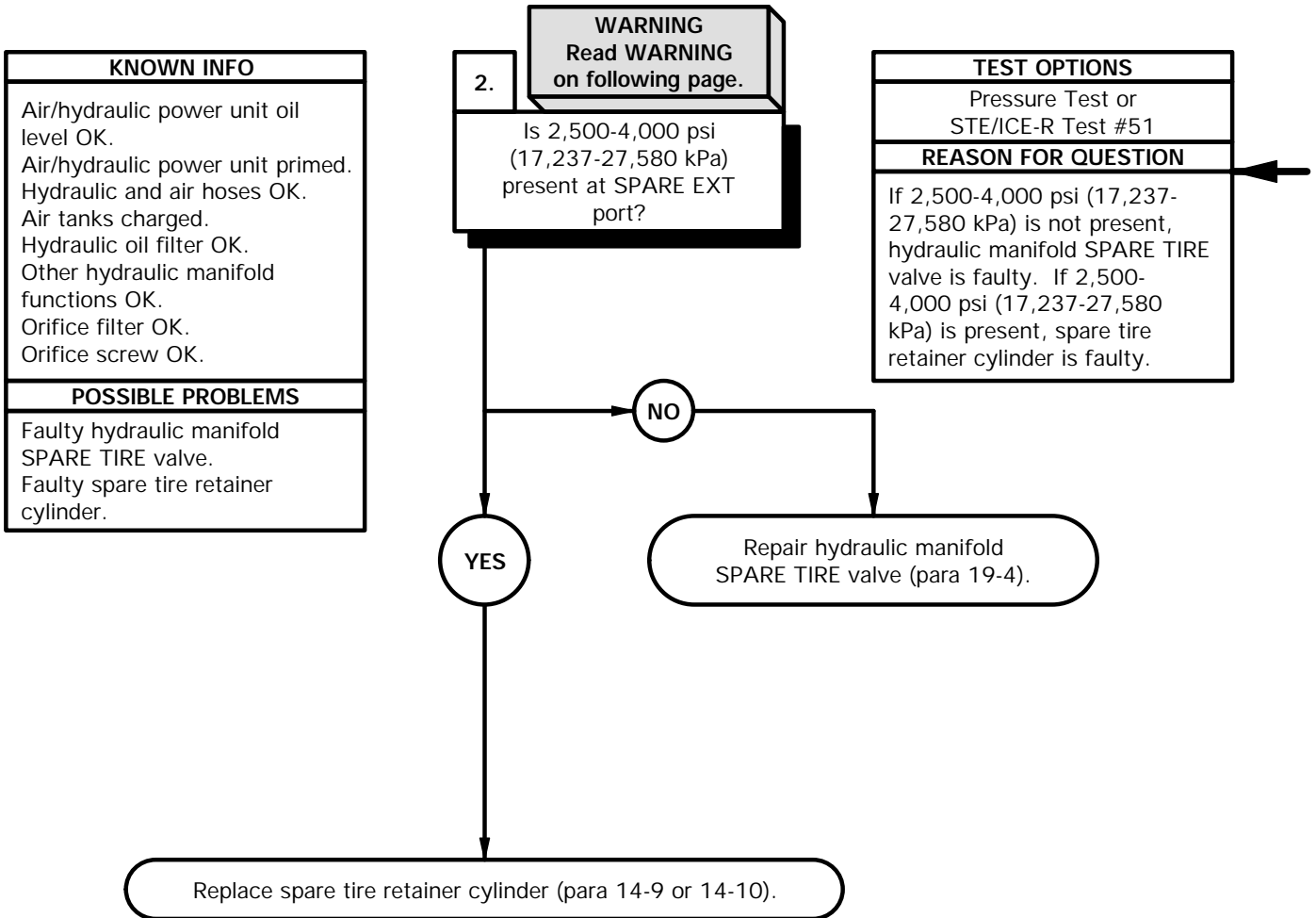

WARNING

Drop hydraulic pressure to zero before disconnecting any hydraulic hoses. Failure to comply may result in injury to personnel.

Hydraulic fluid (MIL-H-5606) is TOXIC. Wear protective goggles and gloves; use only in well ventilated area; avoid contact with skin, eyes, and clothes. Skin and clothing that come into contact with hydraulic fluid should be washed immediately. Saturated clothing should be removed immediately. Failure to comply may result in injury to personnel.

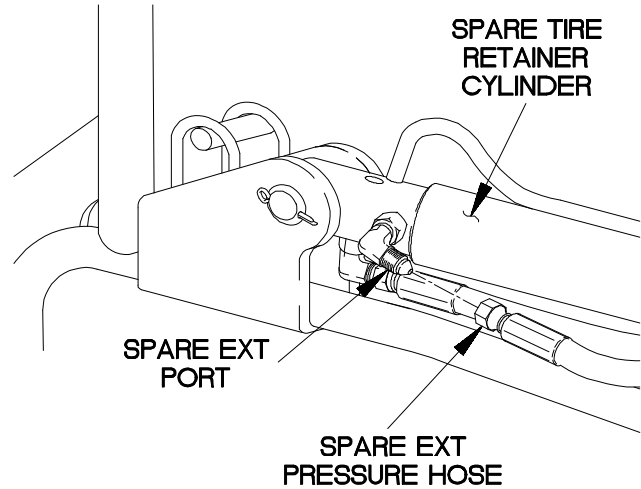

PRESSURE TEST

- (1) Position drain pan under spare tire retainer cylinder.
- (2) Disconnect SPARE EXT pressure hose from spare tire retainer cylinder port.
- (3) Connect STE/ICE-R to SPARE EXT pressure hose.
- (4) Start engine and charge air tanks (TM 9-2320-366-10-1).
- (5) Position SPARE TIRE knob to RAISE.
- (6) Position FUNCTION SELECT knob to SPARE TIRE.
- (7) Push and hold PUMP plunger button and perform STE-ICE-R Test #51 (TM 9-4910-571-12&P).
- (8) If pressure is not 2,500-4,000 psi (17,237-27,580 kPa), repair hydraulic manifold SPARE TIRE valve (para 19-4).
- (9) If pressure is 2,500-4,000 psi (17,237-27,580 kPa), replace spare tire retainer cylinder (para 14-9 or 14-10).
- (10) Drain air tanks (TM 9-2320-366-10-1).
- (11) Disconnect STE/ICE-R from pressure hose.
- (12) Connect pressure hose to spare tire retainer cylinder port.

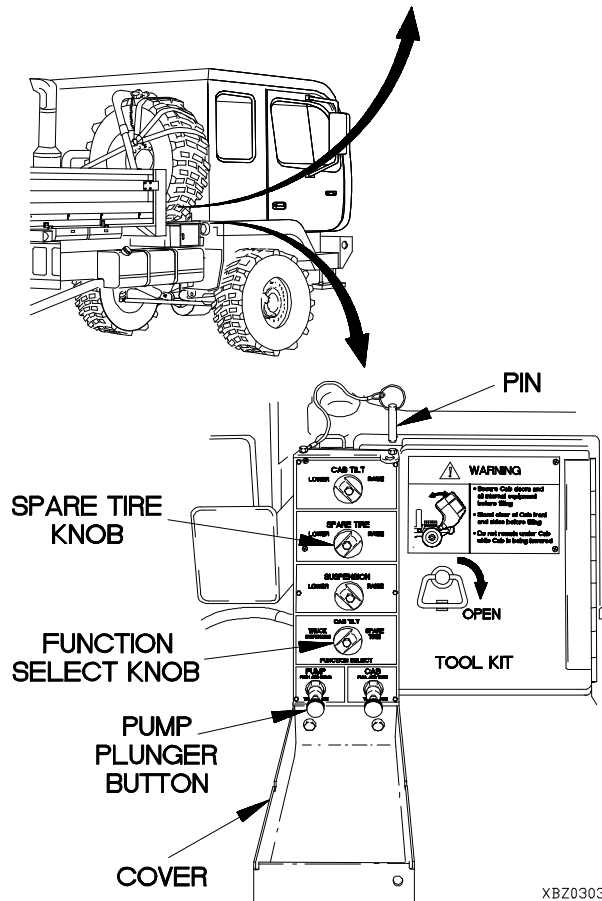

XBZ0303B

z4. SPARE TIRE RETAINER DOES NOT LOWER

INITIAL SETUP

Equipment Condition

Engine shut down (TM 9-2320-366-10-1).
Air tanks drained (TM 9-232-366-10-1).

Personnel Required

(2)

Material/Parts

Rag, Wiping (Item 50, Appendix D)
Filter Element, Fluid (Item 21.1, Appendix G)

Tools and Special Tools

Tool Kit, Genl Mech (Item 46, Appendix C)
STE/ICE-R (Item 41, Appendix C)
Pan, Drain (Item 24, Appendix C)
Goggles, Industrial (Item 15, Appendix C)
Transducer, 10,000 PSI (Item 1, Appendix J)
Wrench, Torque, 0-200 lb-in. (Item 59, Appendix C)
Key, Socket Head Screw (Item 38.1, Appendix B)

References

TM 9-4910-571-12&P

NOTE

On vehicles S/N 0001 through 7558, the hydraulic manifold, P/N 12420621, was not originally equipped with an orifice filter. Orifice filter, P/N 117073098-000, however, may have been installed during previous maintenance to the hydraulic manifold.

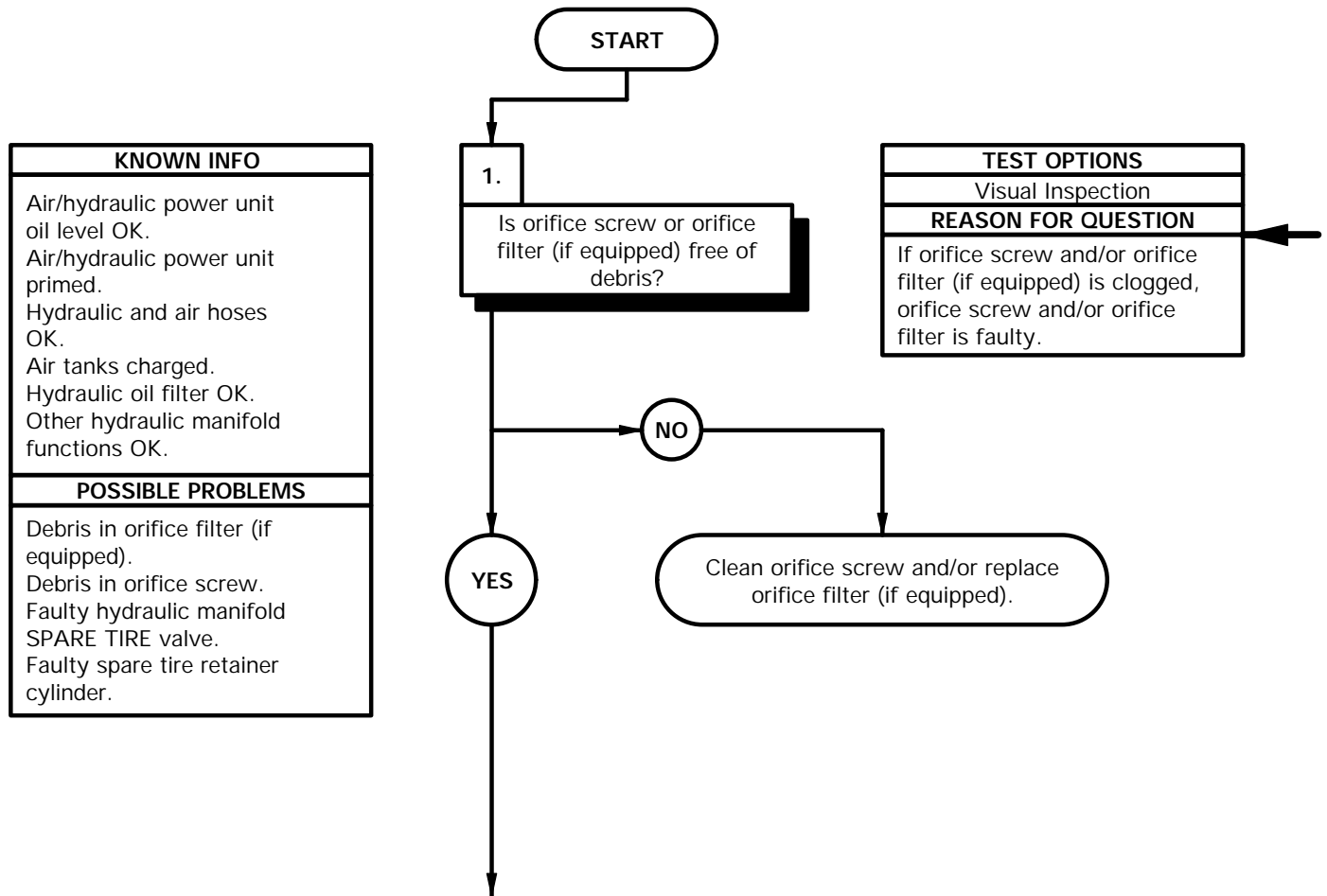

WARNING

Drop hydraulic pressure to zero before disconnecting any hydraulic hoses. Failure to comply may result in injury to personnel.

Hydraulic fluid (MIL-H-5606) is TOXIC. Wear protective goggles and gloves; use only in well ventilated area; avoid contact with skin, eyes, and clothes. Skin and clothing that come into contact with hydraulic fluid should be washed immediately. Saturated clothing should be removed immediately. Failure to comply may result in injury to personnel.

Compressed air used for cleaning purposes will not exceed 30 psi (270 kPa). Use only with effective chip guarding and personal protective equipment (goggles, shields, gloves, etc.). Failure to comply may result in injury to personnel.

NOTE

Perform steps (1) through (12) on hydraulic manifolds installed on vehicles S/N 001 through 7558.

- (1) Remove pin from hydraulic manifold cover and lower cover.
- (2) Cycle FUNCTION SELECT knob through all settings.
- (3) Cycle SPARE TIRE knob through both selector settings.
- (4) Remove screw, knob, and SPARE TIRE valve from hydraulic manifold.
- (5) Remove orifice filter (if equipped) from hydraulic manifold.
- (6) If debris is present in orifice filter, replace orifice filter.
- (7) Remove orifice screw from hydraulic manifold.
- (8) If debris is present in orifice screw, clean orifice screw with compressed air.

NOTE

If no orifice filter was previously installed, orifice filter will be installed at this time.

- (9) Install orifice screw and orifice filter in hydraulic manifold.
- (10) Position SPARE TIRE valve and knob on hydraulic manifold with screw.
- (11) Tighten screw to 5-15 lb-in. (1-2 N-m).
- (12) Close hydraulic manifold cover and install pin.

Cont. on page 2-2416.9.

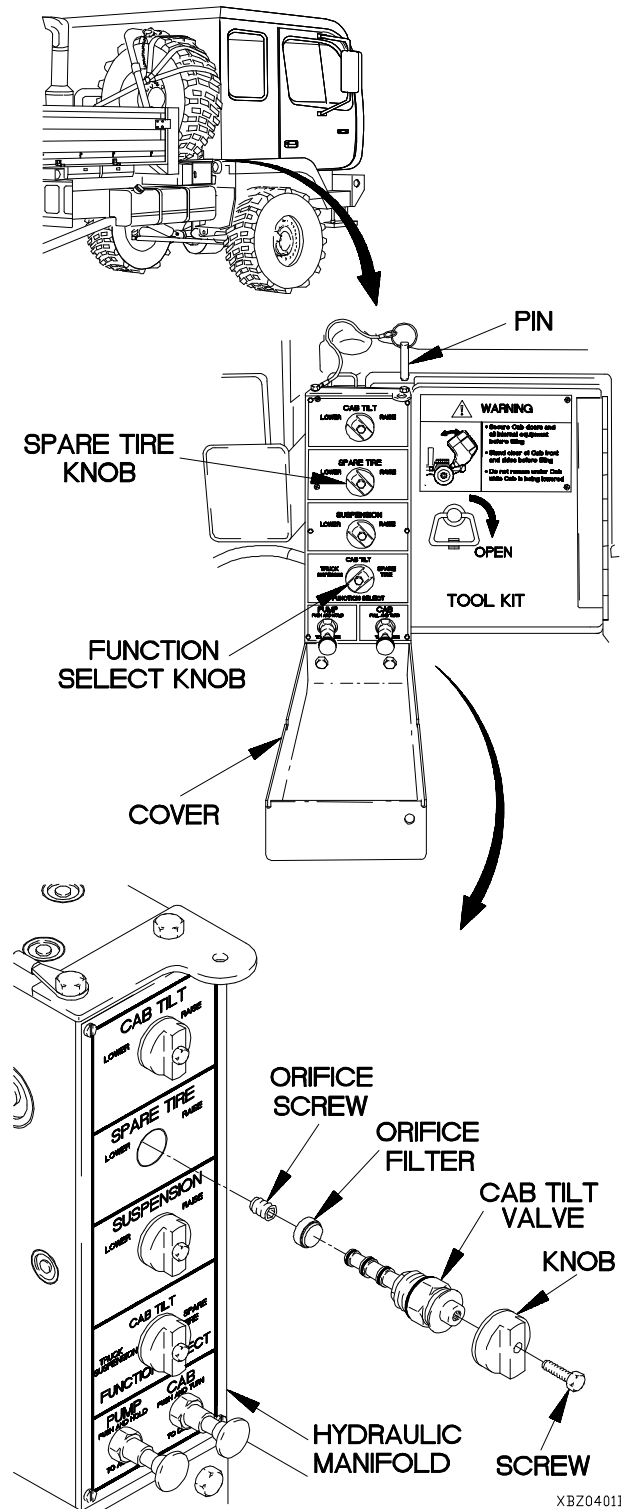

XBZ0401B

Cont. from page 2-2416.7.

WARNING

Drop hydraulic pressure to zero before disconnecting any hydraulic hoses. Failure to comply may result in injury to personnel.

Hydraulic fluid (MIL-H-5606) is TOXIC. Wear protective goggles and gloves; use only in well ventilated area; avoid contact with skin, eyes, and clothes. Skin and clothing that come into contact with hydraulic fluid should be washed immediately. Saturated clothing should be removed immediately. Failure to comply may result in injury to personnel.

Compressed air used for cleaning purposes will not exceed 30 psi (270 kPa). Use only with effective chip guarding and personal protective equipment (goggles, shields, gloves, etc.). Failure to comply may result in injury to personnel.

NOTE

Perform steps (13) through (25) on hydraulic manifolds installed on vehicles S/N 7559 and higher or on vehicles where hydraulic manifolds have two valves on left side.

- (13) Remove pin from hydraulic manifold cover and lower cover.
- (14) Cycle FUNCTION SELECT knob through all settings.
- (15) Cycle SPARE TIRE knob through both selector settings.
- (16) Remove nut, knob, spring, spacer, retainer ring, and rubber sleeve from SPARE TIRE valve.
- (17) Remove SPARE TIRE valve from hydraulic manifold.
- (18) Remove orifice filter from hydraulic manifold.
- (19) If debris is present in orifice filter, replace orifice filter.
- (20) Remove orifice screw from hydraulic manifold.
- (21) If debris is present in orifice screw, clean orifice screw with compressed air.
- (22) Install orifice screw and orifice filter in hydraulic manifold.
- (23) Install SPARE TIRE valve in hydraulic manifold.
- (24) Install rubber sleeve, retainer ring, spacer, spring, knob, and nut on hydraulic manifold.
- (25) Close hydraulic manifold cover and install pin.

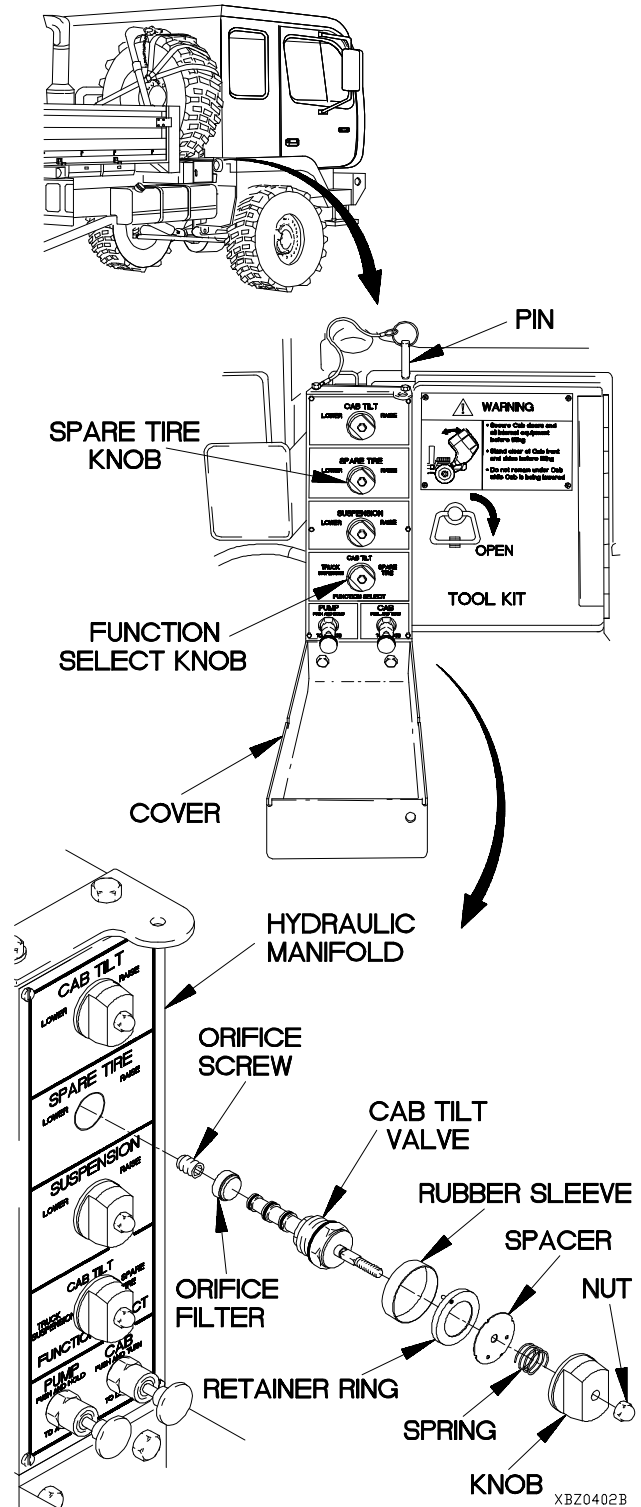

z4. SPARE TIRE RETAINER DOES NOT LOWER (CONT)

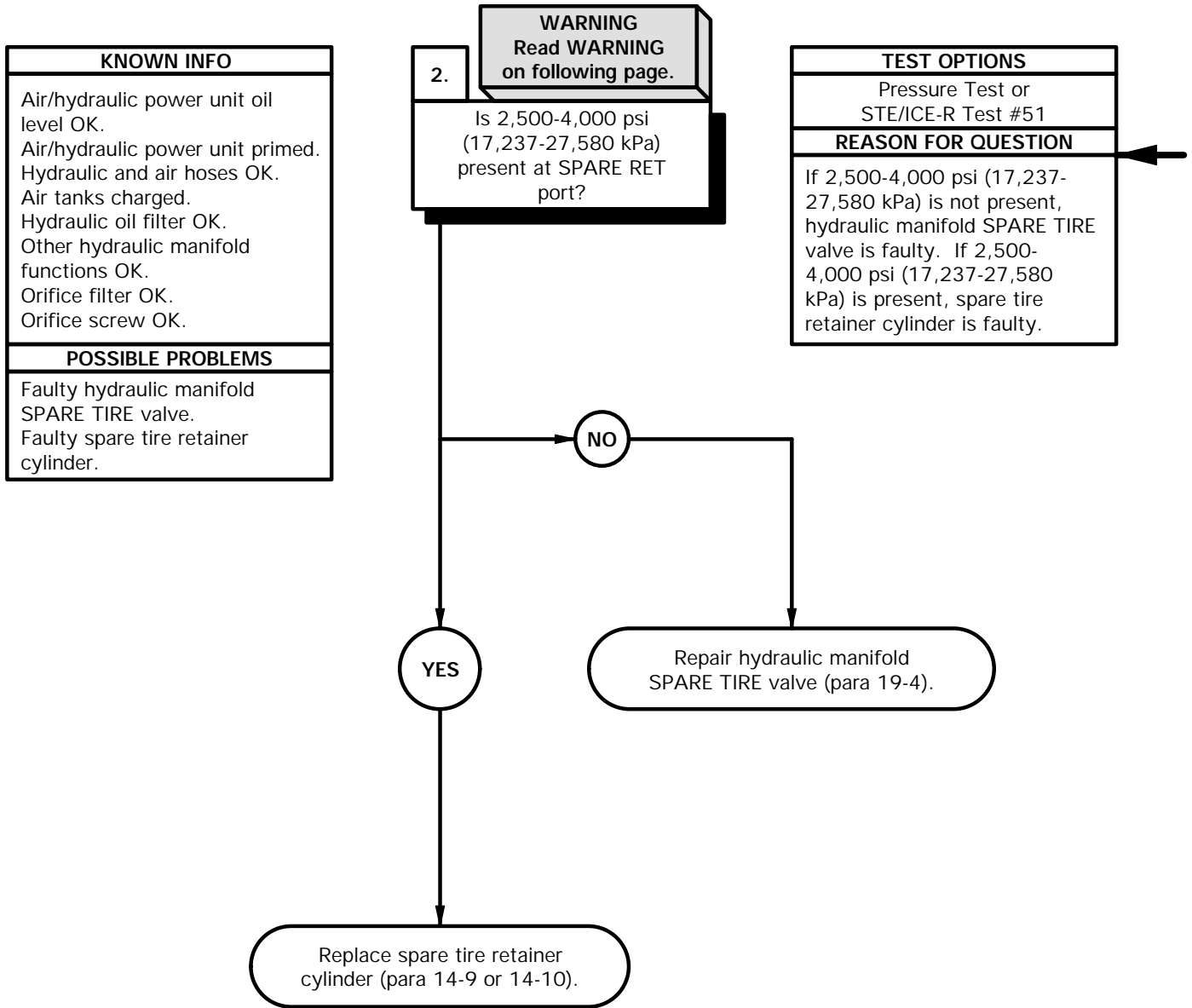

WARNING

Drop hydraulic pressure to zero before disconnecting any hydraulic hoses. Failure to comply may result in injury to personnel.

Hydraulic fluid (MIL-H-5606) is TOXIC. Wear protective goggles and gloves; use only in well ventilated area; avoid contact with skin, eyes, and clothes. Skin and clothing that come into contact with hydraulic fluid should be washed immediately. Saturated clothing should be removed immediately. Failure to comply may result in injury to personnel.

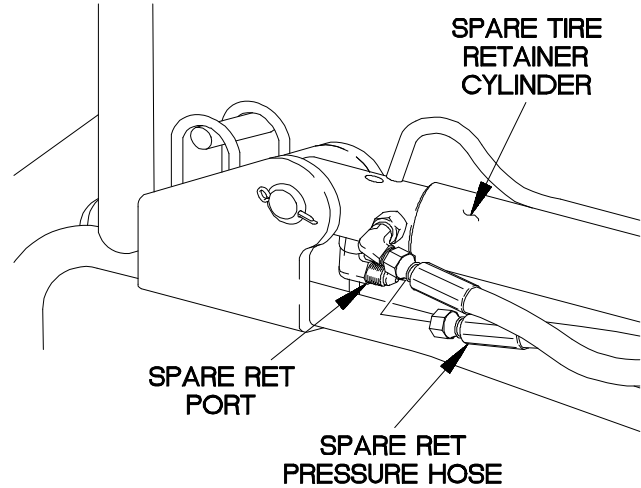

PRESSURE TEST

- (1) Position drain pan under spare tire retainer cylinder.
- (2) Disconnect SPARE RET pressure hose from spare tire retainer cylinder port.
- (3) Connect STE/ICE-R to SPARE RET pressure hose.
- (4) Start engine and charge air tanks (TM 9-2320-366-10-1).
- (5) Position SPARE TIRE knob to LOWER.
- (6) Position FUNCTION SELECT knob to SPARE TIRE.
- (7) Push and hold PUMP plunger button and perform STE-ICE-R Test #51 (TM 9-4910-571-12&P).
- (8) If pressure is not 2,500-4,000 psi (17,237-27,580 kPa), repair hydraulic manifold SPARE TIRE valve (para 19-4).
- (9) If pressure is 2,500-4,000 psi (17,237-27,580 kPa), replace spare tire retainer cylinder (para 14-9 or 14-10).
- (10) Drain air tanks (TM 9-2320-366-10-1).
- (11) Disconnect STE/ICE-R from pressure hose.
- (12) Connect pressure hose to spare tire retainer cylinder port.

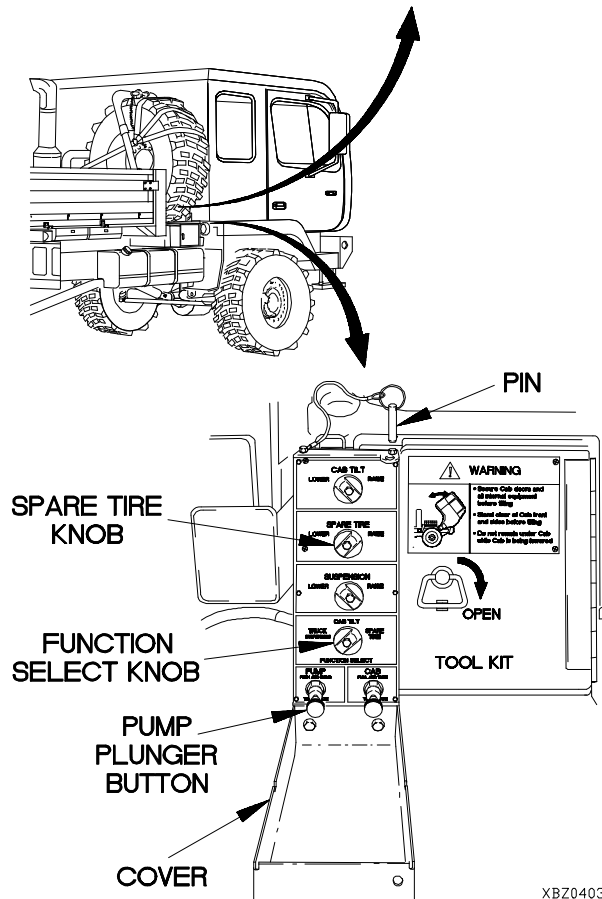

XBZ0403B

2-37. M1089 AIR SYSTEM TROUBLESHOOTING

This paragraph covers M1089 Air System Troubleshooting. The M1089 Air System Fault Index, Table 2-65, lists faults for the M1089 air system of the vehicle.

Table 2-65. M1089 Air System Fault Index

Fault No.	Description	Page
aa1.	M1089 LH or RH 30K Winch Does Not Pay-In	2-2420
aa2.	Main Winch LH FreeSpool Does Not Operate	2-2422
aa3.	Main Winch RH FreeSpool Does Not Operate	2-2426
aa4.	Main Winch LH and RH FreeSpool(s) Do Not Operate	2-2428
aa5.	M1089 LH or RH 30K Winch Cable Drum Tensioner Does Not Operate	2-2430
aa6.	One Wrecker Function Does Not Operate From Wrecker Remote Control	2-2432

aa1. M1089 LH OR RH 30K WINCH DOES NOT PAY-IN

INITIAL SETUP

Equipment Conditions

Engine shut down (TM 9-2320-366-10-1).
Air tanks drained (TM 9-2320-366-10-1).

Tools and Special Tools

Tool Kit, Genl Mech (Item 46, Appendix C)
Goggles, Industrial (Item 15, Appendix C)

Personnel Required

(2)

NOTE

Perform Electrical System Troubleshooting e138A. M1089 LH or RH 30K Winch Does Not Pay-In prior to beginning this task.

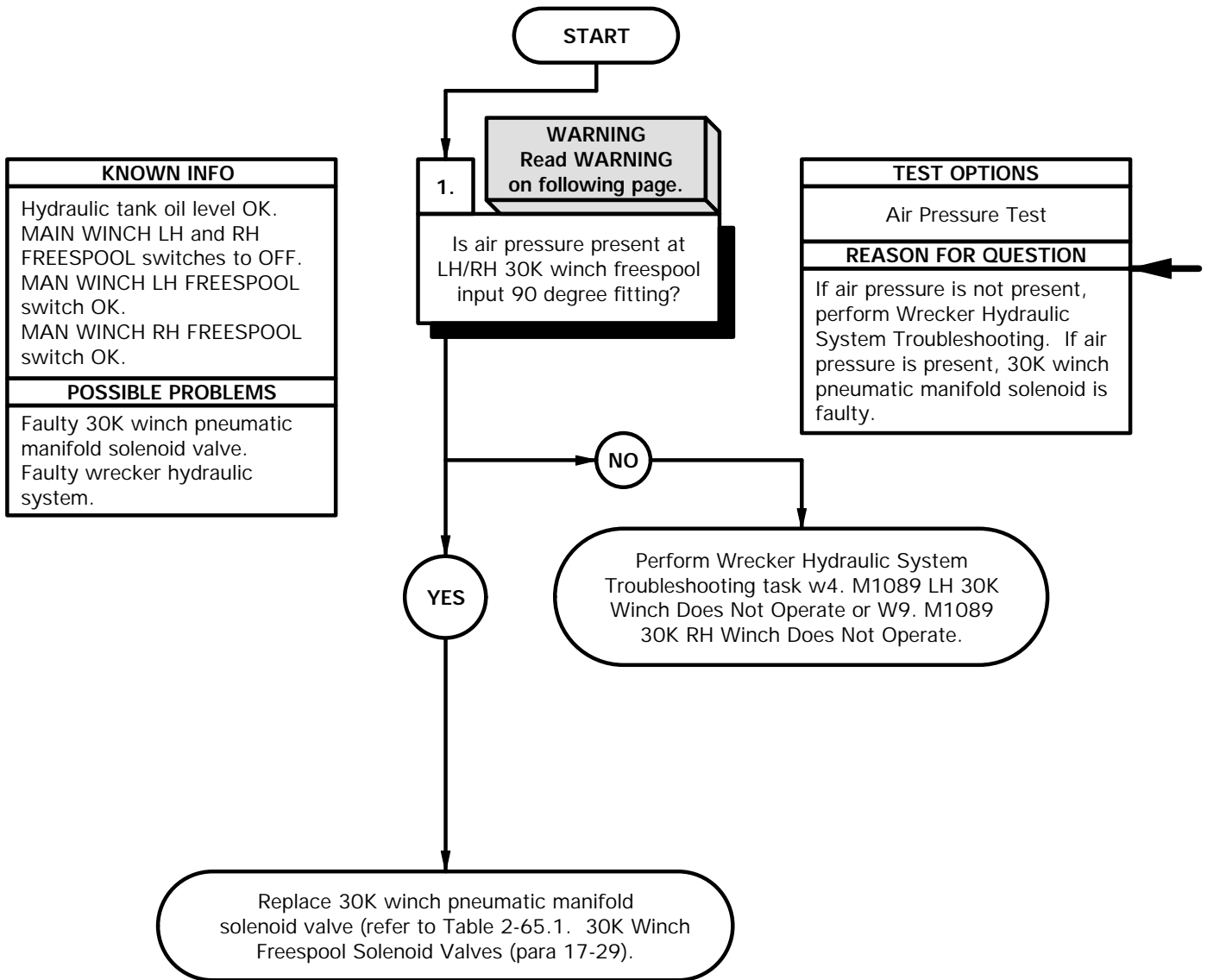

WARNING

Wear protective goggles to protect against possible injury from releases of high pressure air. Failure to comply may result in injury to personnel.

AIR PRESSURE TEST

NOTE

LH and RH air hose are removed the same way. LH hose shown.

- (1) Disconnect air hose from LH/RH 30K winch freespool input 90 degree fitting.
- (2) Start engine (TM 9-2320-366-10-1).
- (3) If air pressure is not present at air hose, perform Wrecker Hydraulic System Troubleshooting task w4. M1089 LH 30K Winch Does Not Operate or w9. M1089 RH 30K Winch Does Not Operate.
- (4) If air pressure is present at air hose, replace 30K winch pneumatic manifold solenoid valve (refer to Table 2-65.1. 30K Winch Freespool Solenoid Valves) (para 17-29).
- (5) Shut down engine (TM 9-2320-366-10-1).
- (6) Connect air hose to LH/RH 30K winch free spool input 90 degree fitting.

Table 2-65.1. 30K Winch Freespool Solenoid Valves

30K Winch	Solenoid
LH	L19
RH	L17

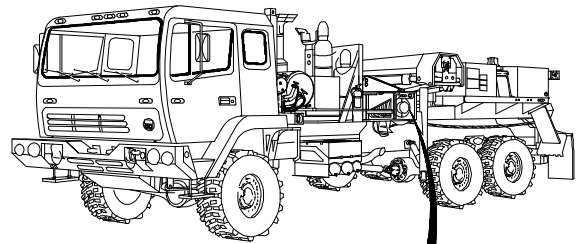

LH 30K WINCH FREESPOOL INPUT 90 DEGREE FITTING

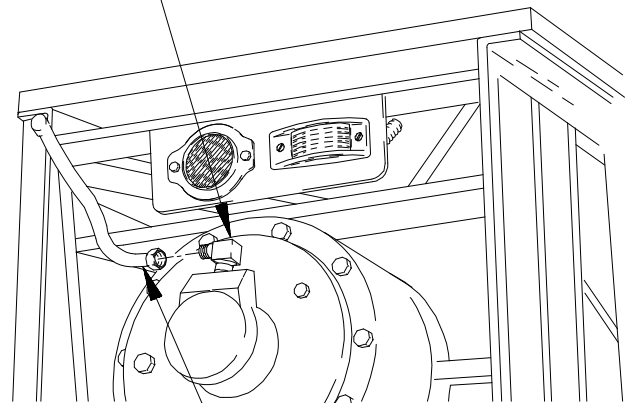

AIR HOSE

XBAA101B

aa2. MAIN WINCH LH FREESPOOL DOES NOT OPERATE

INITIAL SETUP

Equipment Conditions

Engine shut down (TM 9-2320- 366-10-1).
Air tanks drained (TM 9-2320-366-10-1).

Personnel Required

(2)

Tools and Special Tools

Tool Kit, Genl Mech (Item 46, Appendix C)
STE/ICE-R (Item 41, Appendix C)
M1089 30K Winch Pneumatic Test Adapter (Item 25, Appendix E)
Goggles, Industrial (Item 15, Appendix C)

References

TM 9-4910-571-12&P

NOTE

Perform Electrical System Troubleshooting task e140. Main Winch LH or RH Freespool Switch Does Not Operate prior to beginning this task.

KNOWN INFO
LH 30K winch operates. STATION SELECTOR switch to WRECKER CONTROL PANEL. MODE SELECTOR SWITCH to NORMAL. MAIN WINCH LH SPEED switch operates. RH 30K winch freespools. MAIN WINCH LH FREESPOOL switch OK. M1089 control panel wiring harness OK. Terminal block jumper OK.
POSSIBLE PROBLEMS
Faulty 30K winch pneumatic manifold solenoid L19. Faulty air hose. Faulty LH 30K winch assembly.

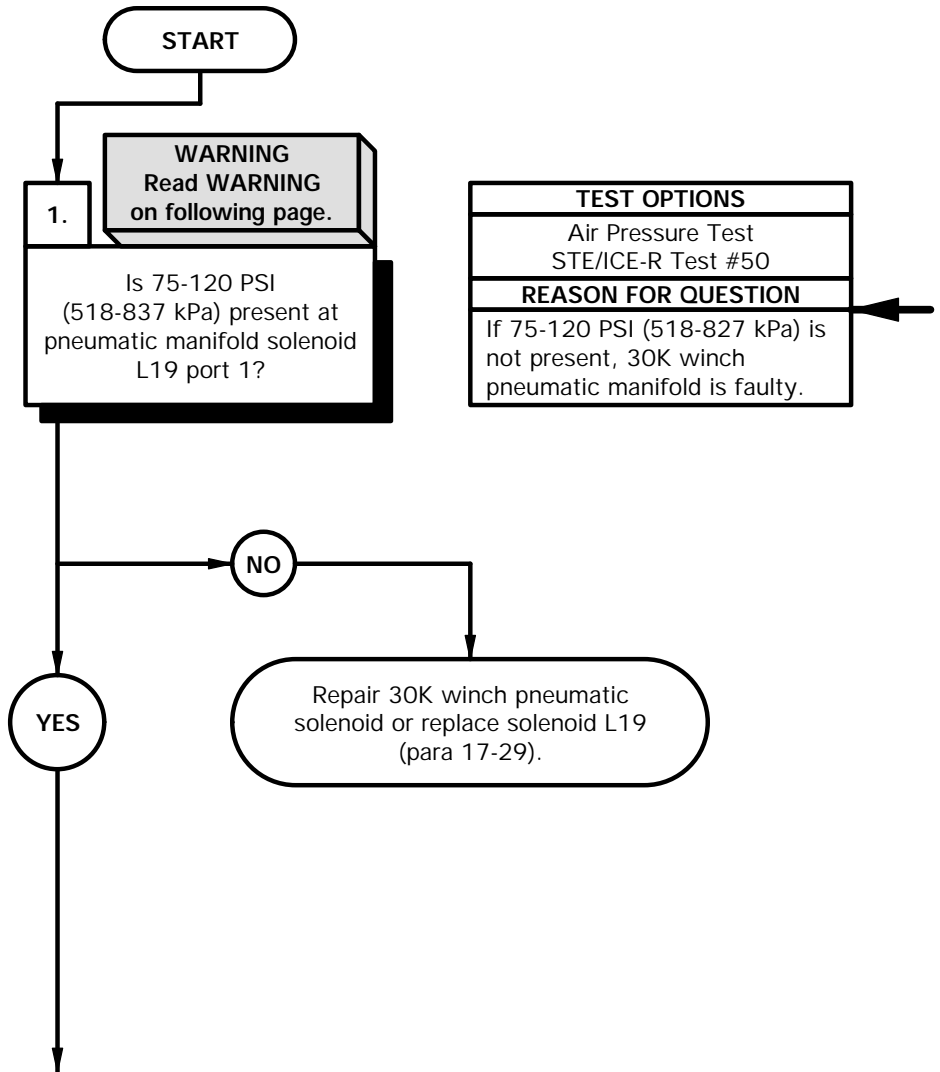

WARNING

Wear protective goggles to protect against possible injury from release of high pressure air. Failure to comply may result in injury to personnel.

NOTE

Tag air hose and connection point prior to disconnecting

AIR PRESSURE TEST STE/ICE-R TEST #50

- (1) Open LH and RH catwalks.
- (2) Disconnect air hose from pneumatic manifold solenoid L19 port 1.
- (3) Remove tube nipple from M1089 30K winch pneumatic test adapter.
- (4) Connect M1089 30K winch pneumatic test adapter on pneumatic manifold solenoid L19 port 1.
- (5) Install STE/ICE-R 0-1000 PSI transducer on M1089 30K winch pneumatic test adapter.
- (6) Start engine (TM 9-2320-366-10-1) and allow vehicle to build air pressure.
- (7) Position MAIN WINCH LH FREESPOOL switch to ON.
- (8) Perform STE/ICE-R Test #50 and note reading on STE/ICE-R.
- (9) If 75-120 PSI (518-827 kPa) is not present, repair 30K winch pneumatic solenoid or replace solenoid L19 (para 17-29).
- (10) Shutdown engine (TM 9-2320-366-10-1).
- (11) Drain air tanks (TM 9-2320-366-10-1).
- (12) Position MAIN WINCH LH FREESPOOL switch to OFF.
- (13) Disconnect M1089 30K winch pneumatic test adapter from pneumatic solenoid L19 port 1.
- (14) Connect air hose to pneumatic solenoid L19 port 1.
- (15) Close LH and RH catwalks.

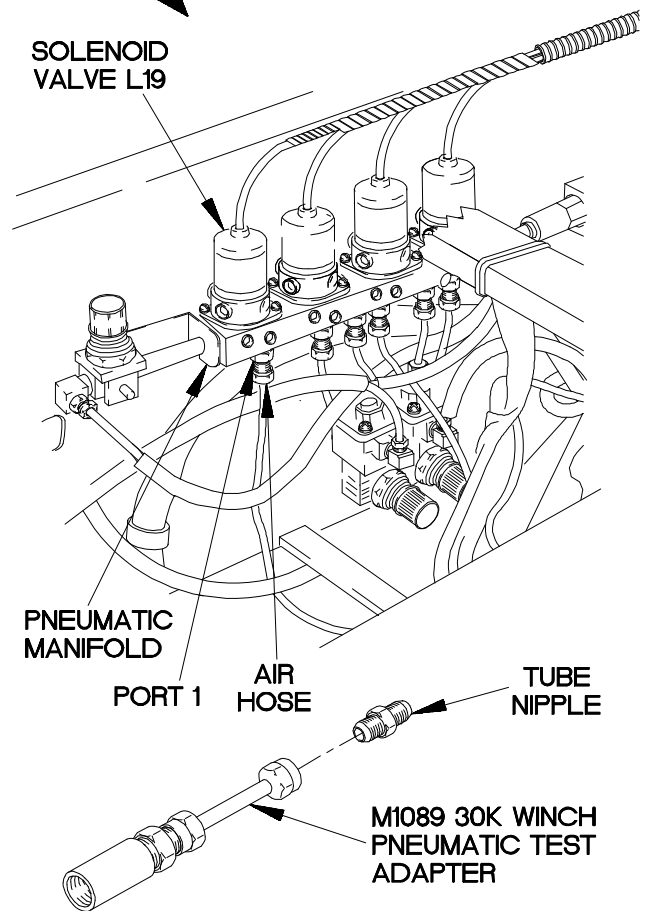
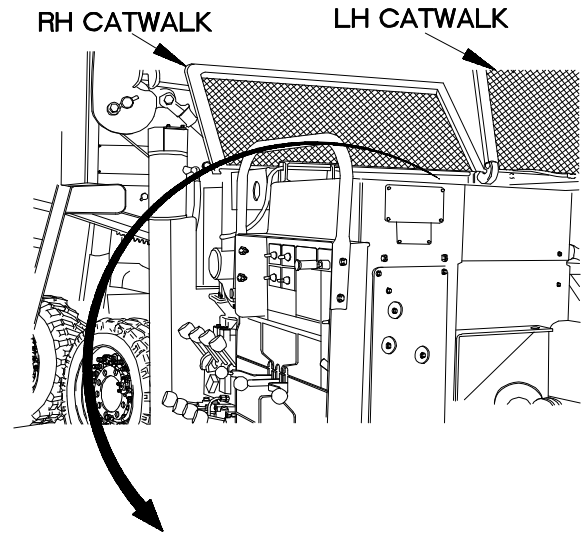

4BAA201B

aa2. MAIN WINCH LH FREESPOOL DOES NOT OPERATE (CONT)

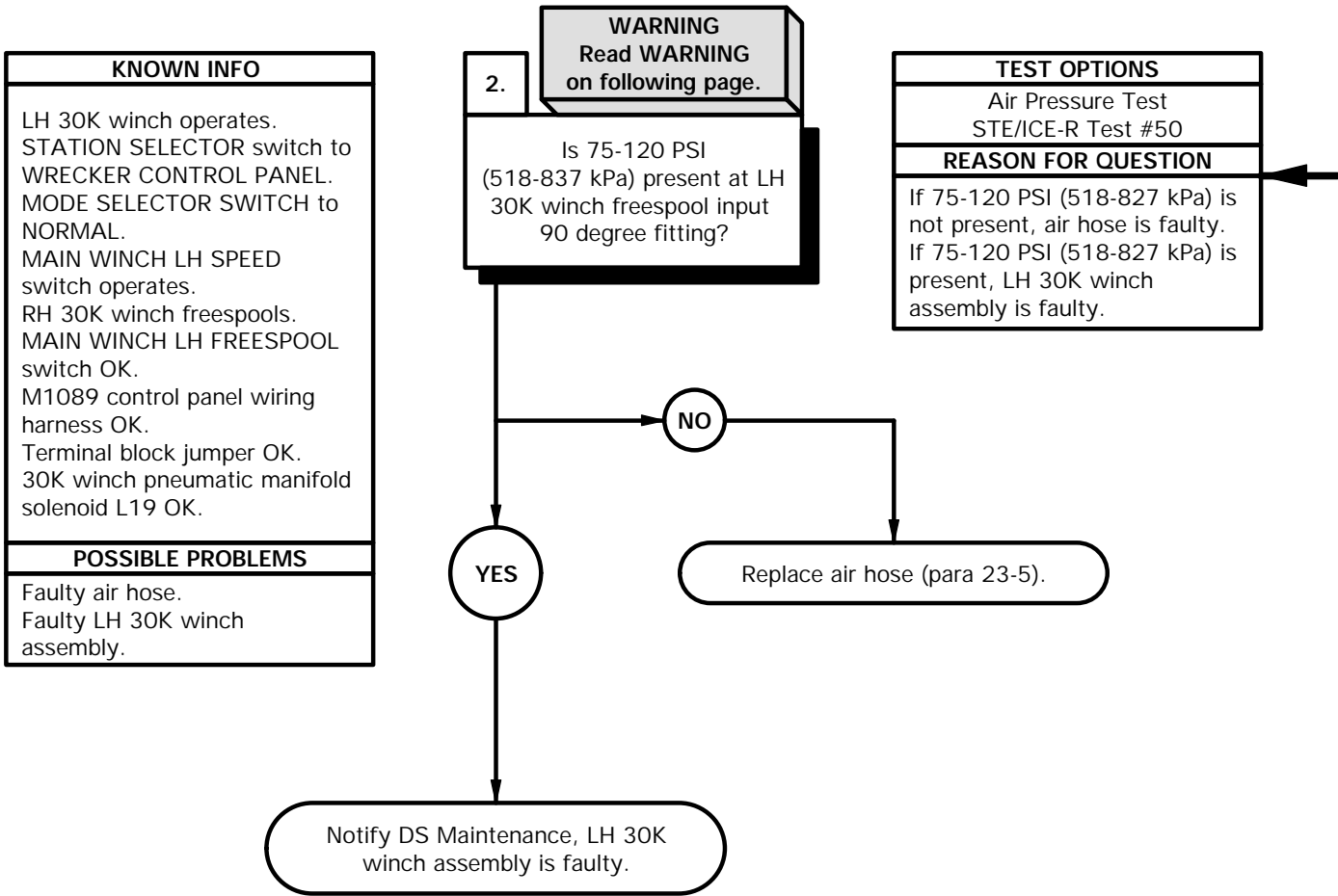

WARNING

Wear protective goggles to protect against possible injury from release of high pressure air. Failure to comply may result in injury to personnel.

NOTE

Tag air hose and connection point prior to disconnecting

AIR PRESSURE TEST STE/ICE-R TEST #50

- (1) Disconnect air hose from LH 30K winch freespool input 90 degree fitting.
- (2) Install tube nipple on M1089 30K winch pneumatic test adapter.
- (3) Connect air hose to M1089 30K winch pneumatic test adapter.
- (4) Start engine (TM 9-2320-366-10-1) and allow vehicle to build air pressure.
- (5) Position MAIN WINCH LH FREESPOOL switch to ON.
- (6) Perform STE/ICE-R Test #50 and note reading on STE/ICE-R.
- (7) If 75-120 PSI (518-827 kPa) is not present, replace air hose (para 23-5).
- (8) If 75-120 PSI (518-827 kPa) is present, notify DS Maintenance, LH 30K winch assembly is faulty.
- (9) Shutdown engine (TM 9-2320-366-10-1).
- (10) Drain air tanks (TM 9-2320-366-10-1).
- (11) Position MAIN WINCH LH FREESPOOL switch to OFF.
- (12) Remove STE/ICE-R 0-1000 PSI transducer from test adapter.
- (13) Disconnect air hose from M1089 30K winch pneumatic test adapter.
- (14) Connect air hose to LH 30K winch free spool 90 degree fitting.

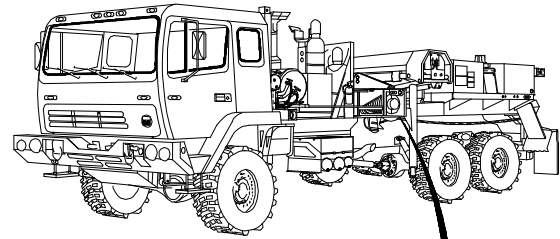

LH 30K WINCH FREESPOOL INPUT 90 DEGREE FITTING

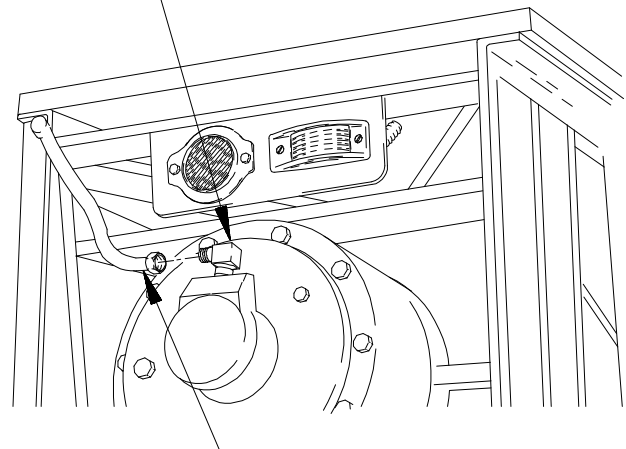

AIR HOSE

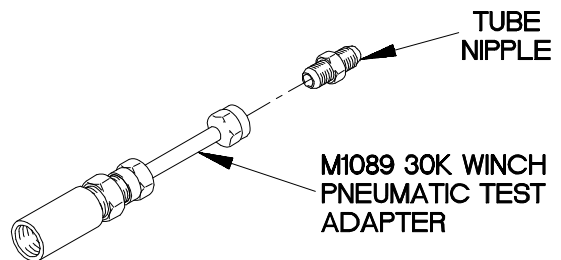

TUBE NIPPLE

M1089 30K WINCH PNEUMATIC TEST ADAPTER

4BAA202B

aa3. MAIN WINCH RH FREESPOOL DOES NOT OPERATE

INITIAL SETUP

Equipment Conditions

Engine shut down (TM 9-2320- 366-10-1).
Air tanks drained (TM 9-2320-366-10-1).

Personnel Required

(2)

Tools and Special Tools

Tool Kit, Genl Mech (Item 46, Appendix C)
STE/ICE-R (Item 41, Appendix C)
M1089 30K Winch Pneumatic Test Adapter (Item 25, Appendix E)
Goggles, Industrial (Item 15, Appendix C)

References

TM 9-4910-571-12&P

NOTE

Perform Electrical System Troubleshooting task e140. Main Winch LH or RH Freespool Switch Does Not Operate prior to beginning this task.

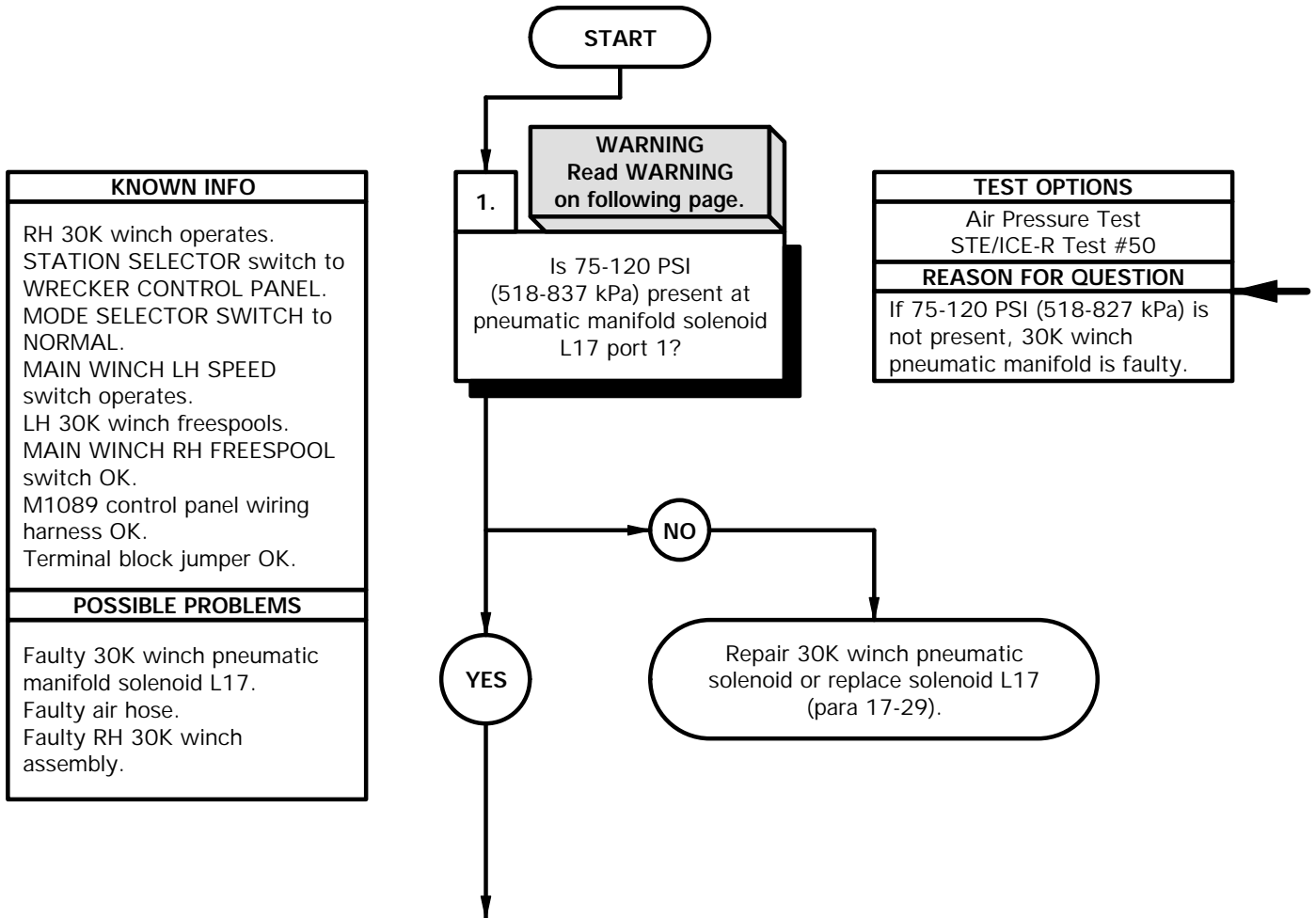

WARNING

Wear protective goggles to protect against possible injury from release of high pressure air. Failure to comply may result in injury to personnel.

NOTE

Tag air hose and connection point prior to disconnecting

AIR PRESSURE TEST STE/ICE-R TEST #50

- (1) Open LH and RH catwalks.
- (2) Disconnect air hose from pneumatic manifold solenoid L17 port 1.
- (3) Remove tube nipple from M1089 30K winch pneumatic test adapter.
- (4) Connect M1089 30K winch pneumatic test adapter on pneumatic manifold solenoid L17 port 1.
- (5) Install STE/ICE-R 0-1000 PSI transducer on M1089 30K winch pneumatic test adapter.
- (6) Start engine (TM 9-2320-366-10-1) and allow vehicle to build air pressure.
- (7) Position MAIN WINCH RH FREESPOOL switch to ON.
- (8) Perform STE/ICE-R Test #50 and note reading on STE/ICE-R.
- (9) If 75-120 PSI (518-827 kPa) is not present, repair 30K winch pneumatic solenoid or replace solenoid L17 (para 17-29).
- (10) Shutdown engine (TM 9-2320-366-10-1).
- (11) Drain air tanks (TM 9-2320-366-10-1).
- (12) Position MAIN WINCH RH FREESPOOL switch to OFF.
- (13) Disconnect M1089 30K winch pneumatic test adapter from pneumatic solenoid L19 port 1.
- (14) Connect air hose to pneumatic solenoid L17 port 1.
- (15) Close LH and RH catwalks.

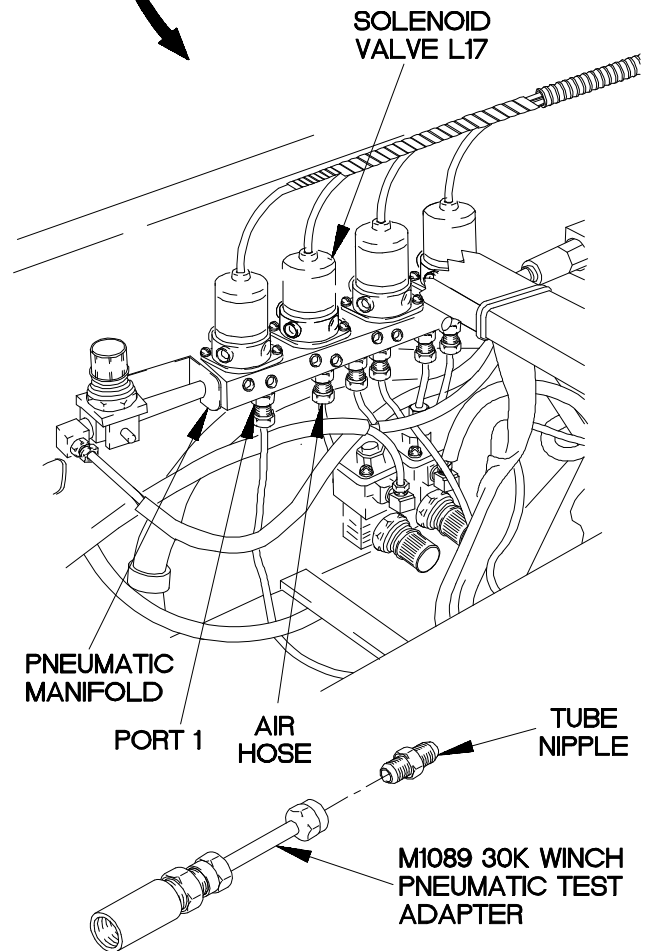
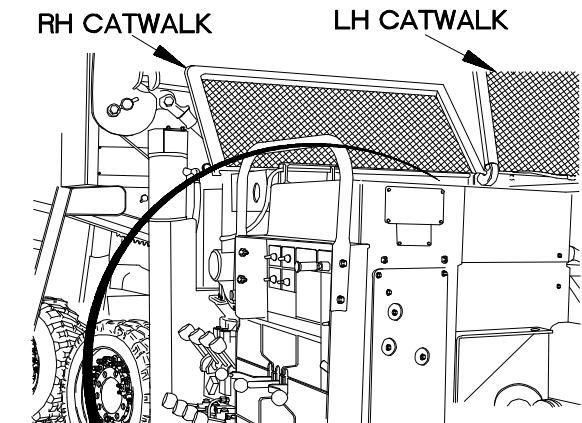

4BAA301B

aa3. MAIN WINCH RH FREESPOOL DOES NOT OPERATE (CONT)

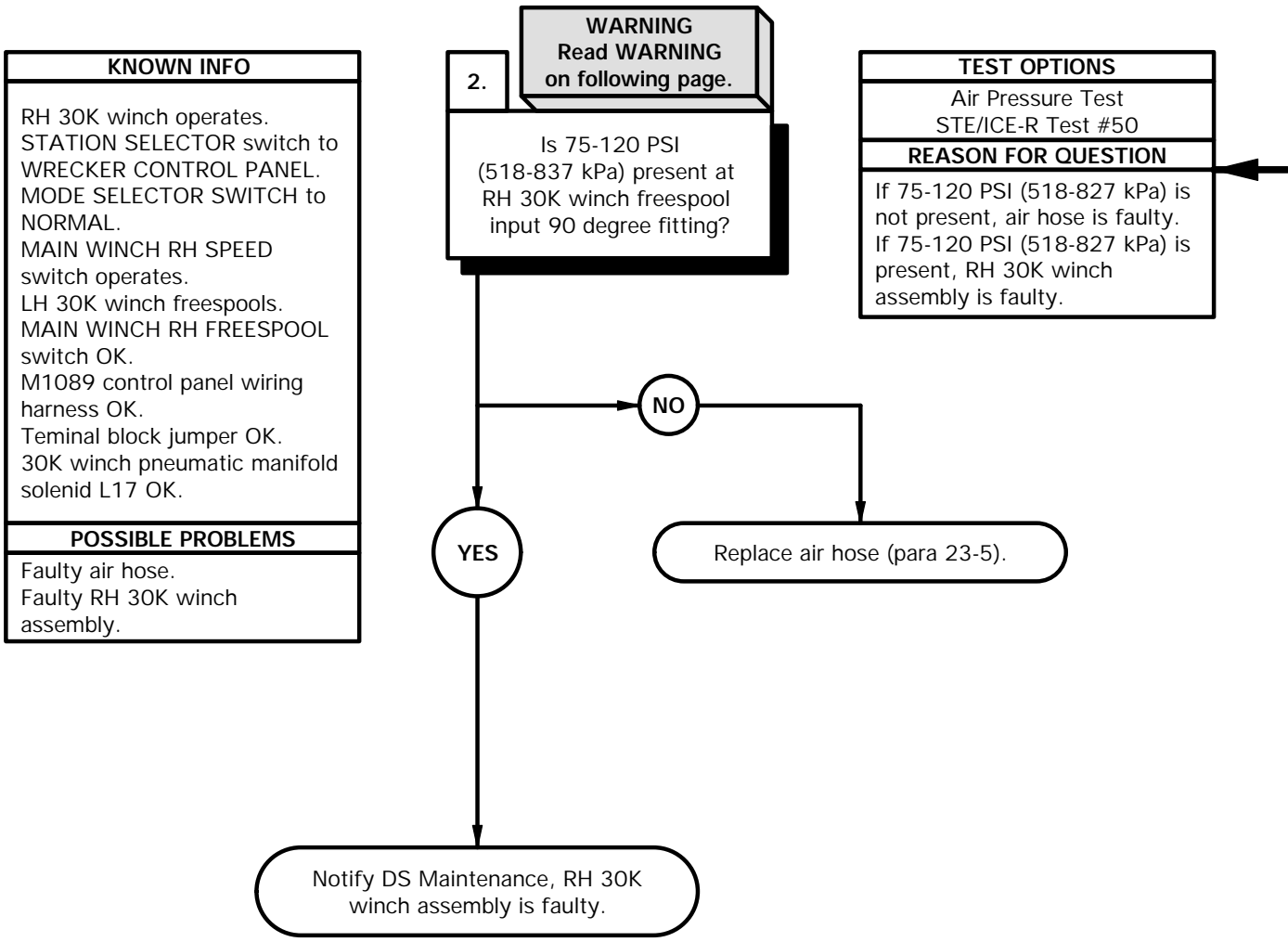

WARNING

Wear protective goggles to protect against possible injury from release of high pressure air. Failure to comply may result in injury to personnel.

NOTE

Tag air hose and connection point prior to disconnecting

AIR PRESSURE TEST STE/ICE-R TEST #50

- (1) Disconnect air hose from RH 30K winch freespool input 90 degree fitting.
- (2) Install tube nipple on M1089 30K winch pneumatic test adapter.
- (3) Connect air hose to M1089 30K winch pneumatic test adapter.
- (4) Start engine (TM 9-2320-366-10-1) and allow vehicle to build air pressure.
- (5) Position MAIN WINCH RH FREESPOOL switch to ON.
- (6) Perform STE/ICE-R Test #50 and note reading on STE/ICE-R.
- (7) If 75-120 PSI (518-827 kPa) is not present, replace air hose (para 23-5).
- (8) If 75-120 PSI (518-827 kPa) is present, notify DS Maintenance, RH 30K winch assembly is faulty.
- (9) Shutdown engine (TM 9-2320-366-10-1).
- (10) Drain air tanks (TM 9-2320-366-10-1).
- (11) Position MAIN WINCH RH FREESPOOL switch to OFF.
- (12) Remove STE/ICE-R 0-1000 PSI transducer from M1089 30K winch pneumatic test adapter.
- (13) Disconnect air hose from M1089 30K winch pneumatic test adapter.
- (14) Connect air hose to RH 30K winch free spool 90 degree fitting.

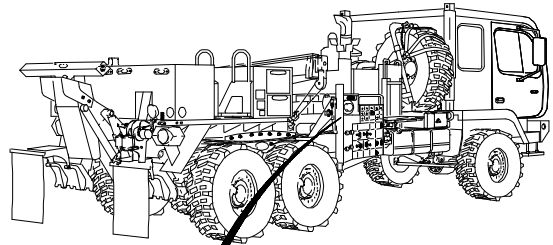

RH 30K WINCH FREESPOOL INPUT 90 DEGREE FITTING

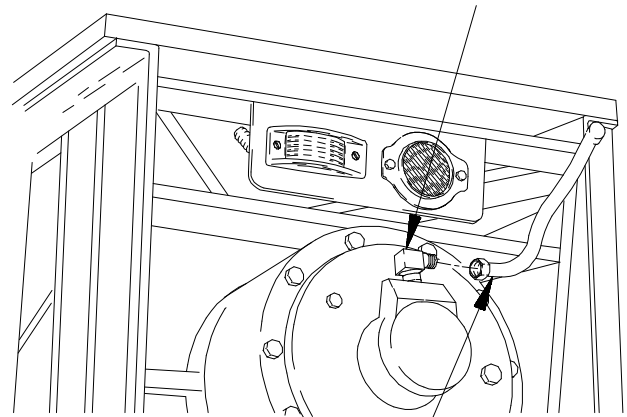

AIR HOSE

TUBE NIPPLE

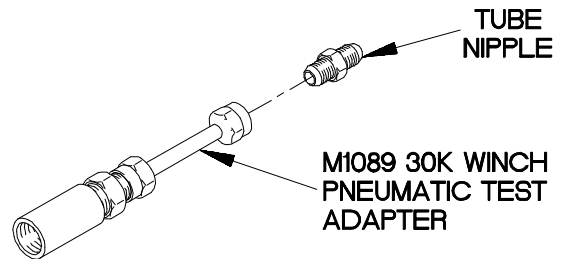

M1089 30K WINCH PNEUMATIC TEST ADAPTER

4BAA302B

aa4. MAIN WINCH LH AND RH FREESPOOLS DO NOT OPERATE

INITIAL SETUP

Equipment Conditions

Engine shut down (TM 9-2320- 366-10-1).
Air tanks drained (TM 9-2320-366-10-1).

Personnel Required
(2)

References

TM 9-4910-571-12&P

Tools and Special Tools

Tool Kit, Genl Mech (Item 46, Appendix C)
STE/ICE-R (Item 41, Appendix C)
M1089 30K Winch Pneumatic Test Adapter (Item 25, Appendix E)
M1089 30K Winch Test Adapter (Item 7, Appendix E)
Goggles, Industrial (Item 15, Appendix C)

Material/Parts

Tape, Antiseizing (Item 66, Appendix D)

NOTE

Perform Electrical System Troubleshooting task e140. Main Winch LH or RH Freespool Switch Does Not Operate prior to beginning this task.

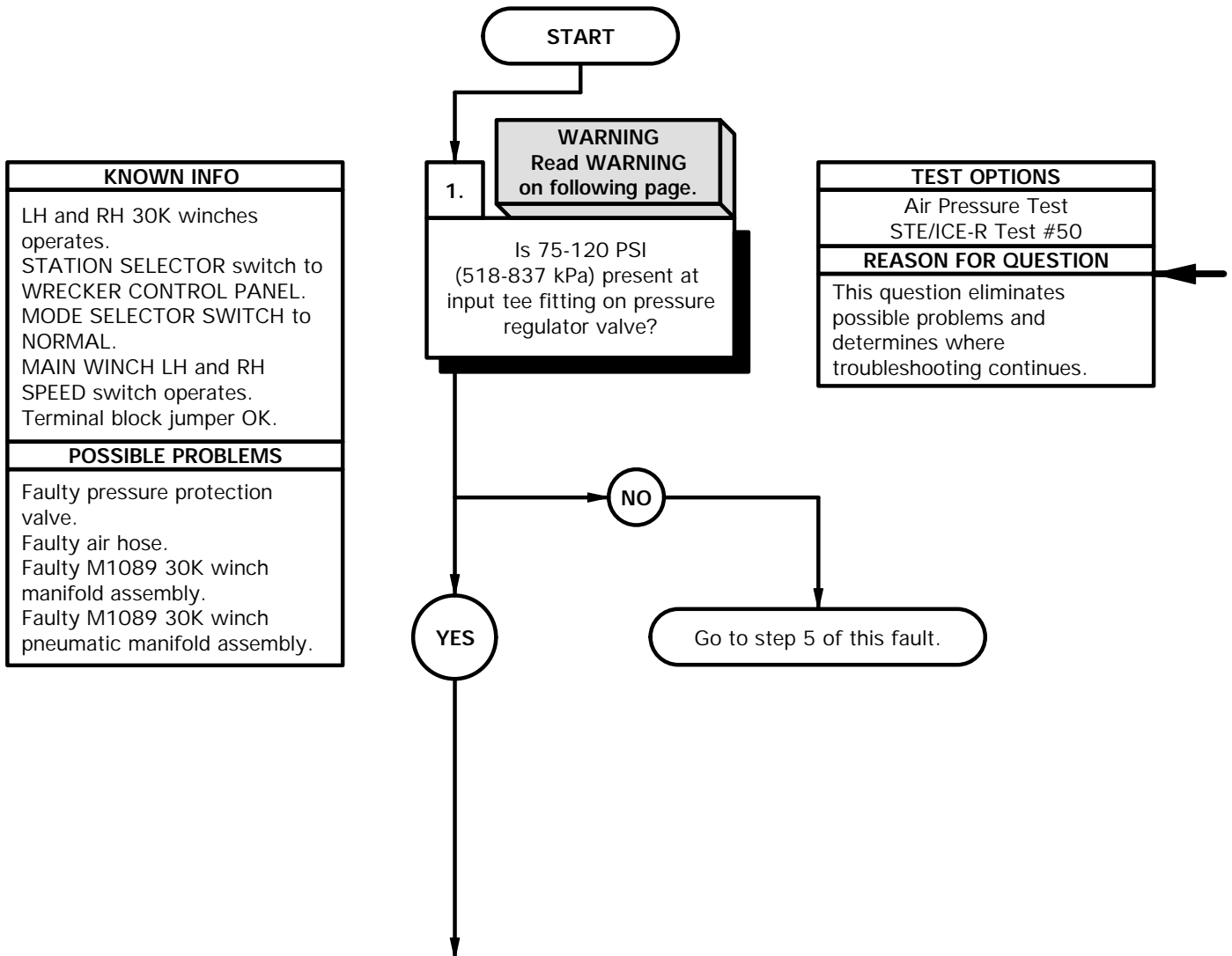

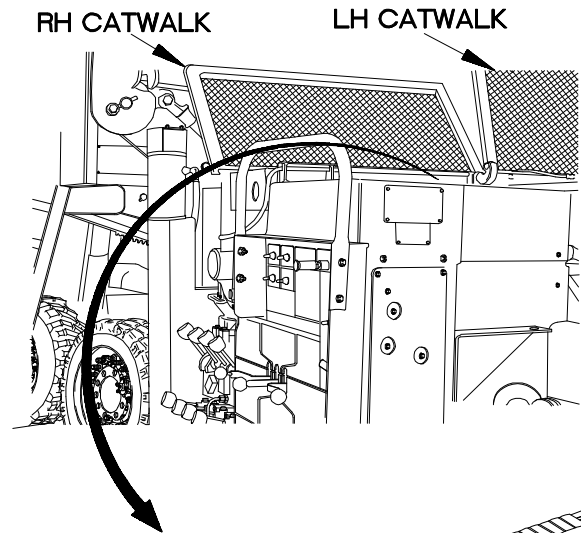

WARNING

Wear protective goggles to protect against possible injury from release of high pressure air. Failure to comply may result in injury to personnel.

NOTE

Tag air hose and connection point prior to disconnecting

- AIR PRESSURE TEST STE/ICE-R TEST #50**
- (1) Open LH and RH catwalks.
 - (2) Disconnect input air hose from input tee fitting on pressure regulator.
 - (3) Connect input air hose to M1089 30K winch pneumatic test adapter.
 - (4) Install STE/ICE-R 0-1000 PSI transducer on M1089 30K winch pneumatic test adapter.
 - (5) Start engine (TM 9-2320-366-10-1).
 - (6) Perform STE/ICE-R Test #50 and note reading on STE/ICE-R.
 - (7) If 75-120 PSI (518-827 kPa) is not present, go to step 5 of this fault.
 - (8) Shut down engine (TM 9-2320-366-10-1).
 - (9) Drain air tanks (TM 9-2320-366-10-1).
 - (10) Disconnect input air hose from M1089 30K winch pneumatic test adapter.

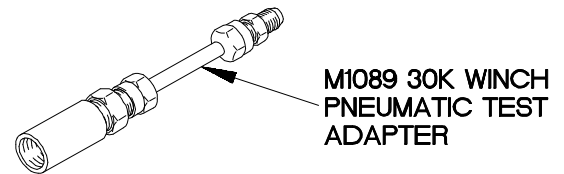
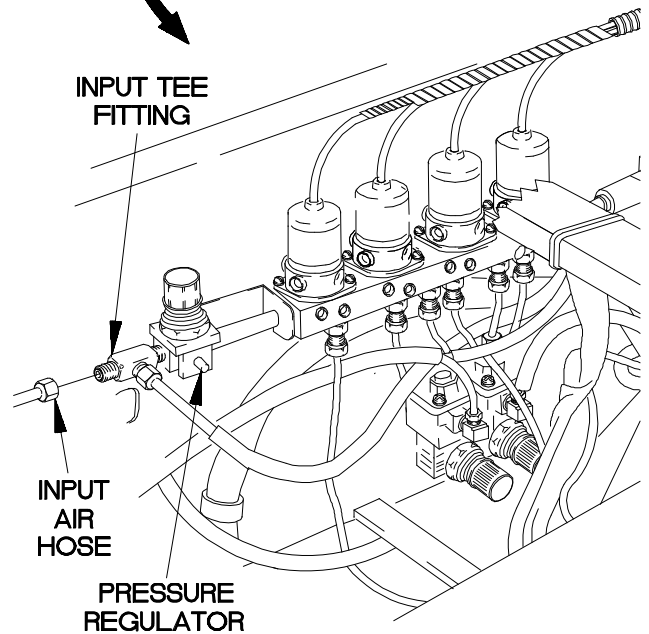

4BAA401B

aa4. MAIN WINCH LH AND RH FREESPOOLS DO NOT OPERATE (CONT)

NOTE

Ensure that pressure regulator valve is fully open by lifting knob and turning clockwise.

KNOWN INFO
LH and RH 30K winches operates. STATION SELECTOR switch to WRECKER CONTROL PANEL. MODE SELECTOR SWITCH to NORMAL. MAIN WINCH LH and RH SPEED switch operates. Terminal block jumper OK. Pressure protection valve OK.
POSSIBLE PROBLEMS
Faulty air hose. Faulty M1089 30K winch manifold assembly. Faulty M1089 30K winch pneumatic manifold assembly.

2.

WARNING
Read **WARNING** on following page.

Is 75-120 PSI (518-827 kPa) present through M1089 30K winch pneumatic manifold?

TEST OPTIONS
Air Pressure Test STE/ICE-R Test #50
REASON FOR QUESTION
If 75-120 PSI (518-827 kPa) is not present, M1089 30K winch pneumatic manifold is faulty.

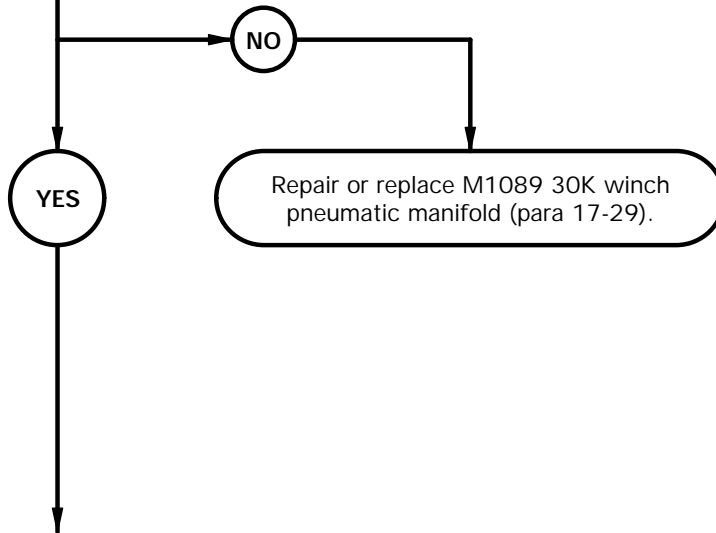

WARNING

Wear protective goggles to protect against possible injury from release of high pressure air. Failure to comply may result in injury to personnel.

NOTE

Tag air hose and connection point prior to disconnecting

AIR PRESSURE TEST STE/ICE-R TEST #50

- (1) Remove STE/ICE-R 0-1000 PSI transducer from M1089 30K winch pneumatic tester.
- (2) Connect M1089 30K winch test adapter to input tee fitting.
- (3) Install STE/ICE-R 0-1000 PSI transducer in M1089 30K winch test adapter.
- (4) Connect input air hose to M1089 30K winch test adapter.
- (5) Disconnect air hose from input tee fitting.
- (6) Remove tube nipple from M1089 30K winch pneumatic test adapter.
- (7) Connect M1089 30K winch pneumatic test adapter to input tee fitting.

NOTE

Apply antiseizing tape to first two to five threads of plug prior to installation.

- (8) Install plug in M1089 30K winch pneumatic test adapter.
- (9) Start engine (TM9-2320-366-10-1) and allow vehicle to build air pressure.
- (10) Perform STE/ICE-R Test #50 and note reading on STE/ICE-R.
- (11) If 75-120 PSI (518-827 kPa) is not present, repair or replace M1089 30K winch pneumatic manifold (para 17-29).
- (12) Shut down engine (TM 902320-366-10-1).
- (13) Drain air tanks (TM9-2320-366-10-1).
- (14) Remove plug from M1089 30K winch pneumatic test adapter.
- (15) Disconnect M1089 30K winch pneumatic test adapter from input tee fitting.
- (16) Install tube nipple on 30K winch pneumatic test adapter.
- (17) Connect air hose to input tee fitting.
- (18) Disconnect input air hose from M1089 30K winch test adapter.
- (19) Remove STE/ICE-R 0-1000 PSI transducer from M1089 30K winch test adapter.
- (20) Disconnect M1089 30K winch test adapter from input tee fitting.
- (21) Connect input air hose to input tee fitting.

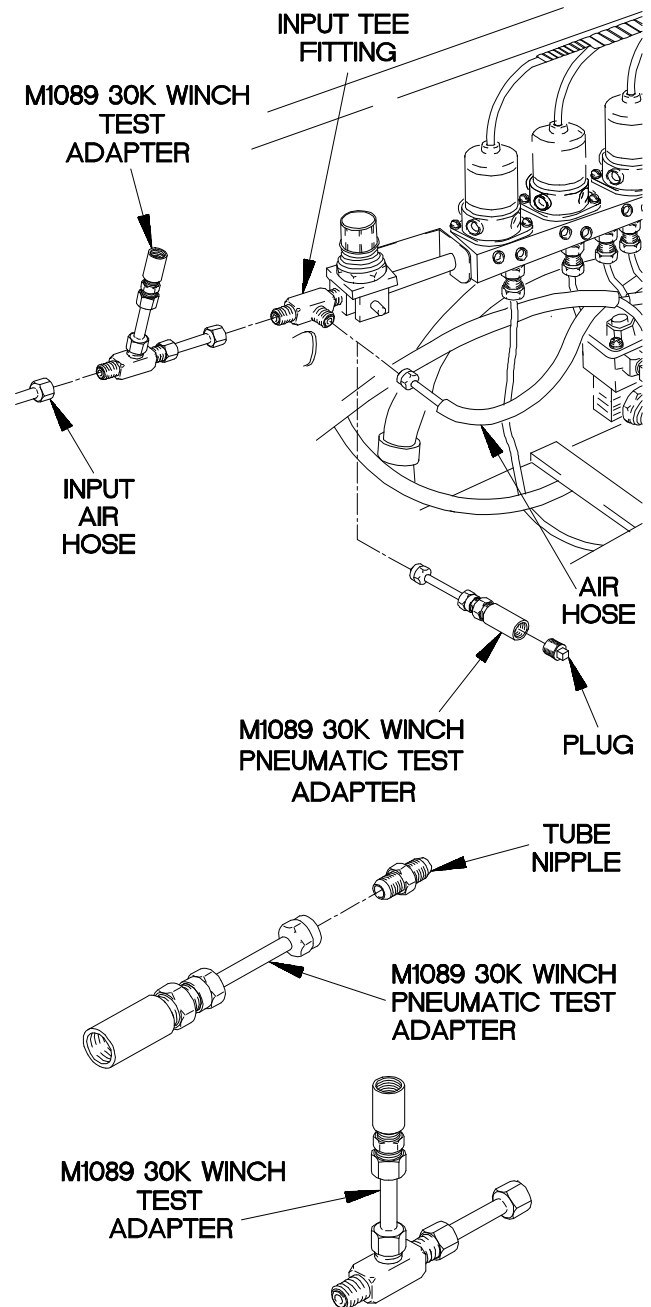

4BAA402B

aa4. MAIN WINCH LH AND RH FREESPOOLS DO NOT OPERATE (CONT)

KNOWN INFO
LH and RH 30K winches operates. STATION SELECTOR switch to WRECKER CONTROL PANEL. MODE SELECTOR SWITCH to NORMAL. MAIN WINCH LH and RH SPEED switch operates. Terminal block jumper OK. Pressure protection valve OK.
POSSIBLE PROBLEMS
Faulty air hose. Faulty M1089 30K winch manifold assembly. Faulty M1089 30K winch pneumatic manifold assembly.

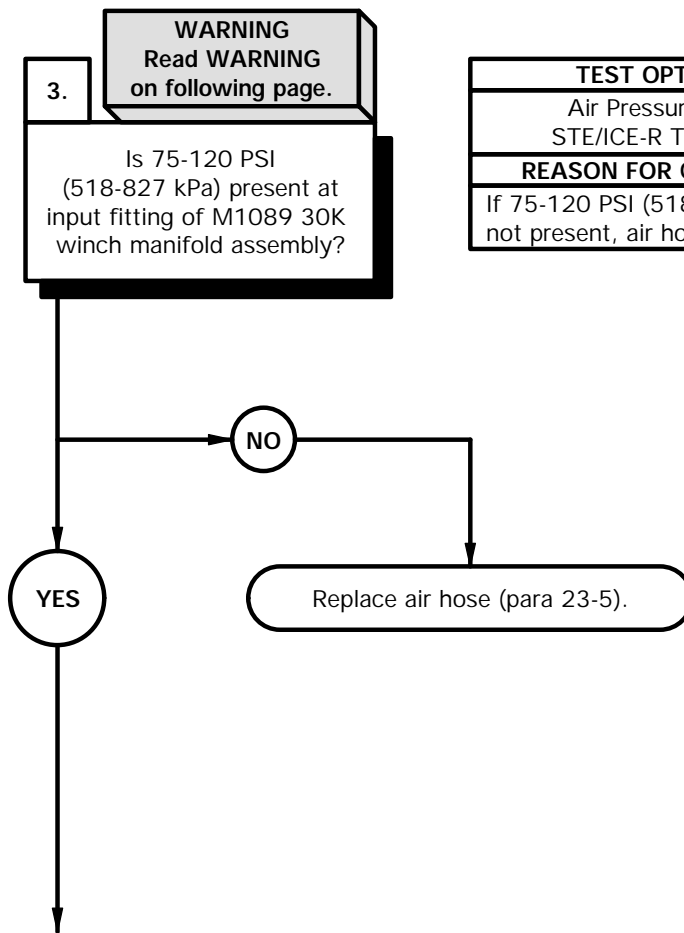

WARNING

Wear protective goggles to protect against possible injury from release of high pressure air. Failure to comply may result in injury to personnel.

NOTE

Tag air hose and connection point prior to disconnecting

AIR PRESSURE TEST STE/ICE-R TEST #50

- (1) Remove wrecker control panel top cover (para 14-4).
- (2) Disconnect air hose from input fitting of 30K winch manifold assembly.
- (3) Connect air hose to M1089 30K winch pneumatic test adapter.
- (4) Install STE/ICE-R 0-1000 PSI transducer in M1089 30K winch pneumatic test adapter.
- (5) Start engine (TM9-2320-366-10-1) and allow vehicle to build air pressure.
- (6) Perform STE/ICE-R Test #50 and note reading on STE/ICE-R.
- (7) If 75-120 PSI (518-827 kPa) is not present, replace air hose (para 23-5).
- (8) Shut down engine (TM 902320-366-10-1).
- (9) Drain air tanks (TM9-2320-366-10-1).
- (10) Remove STE/ICE-R 0-1000 PSI transducer from M1089 30K winch pneumatic test adapter.
- (11) Disconnect air hose from M1089 30K winch pneumatic test adapter.

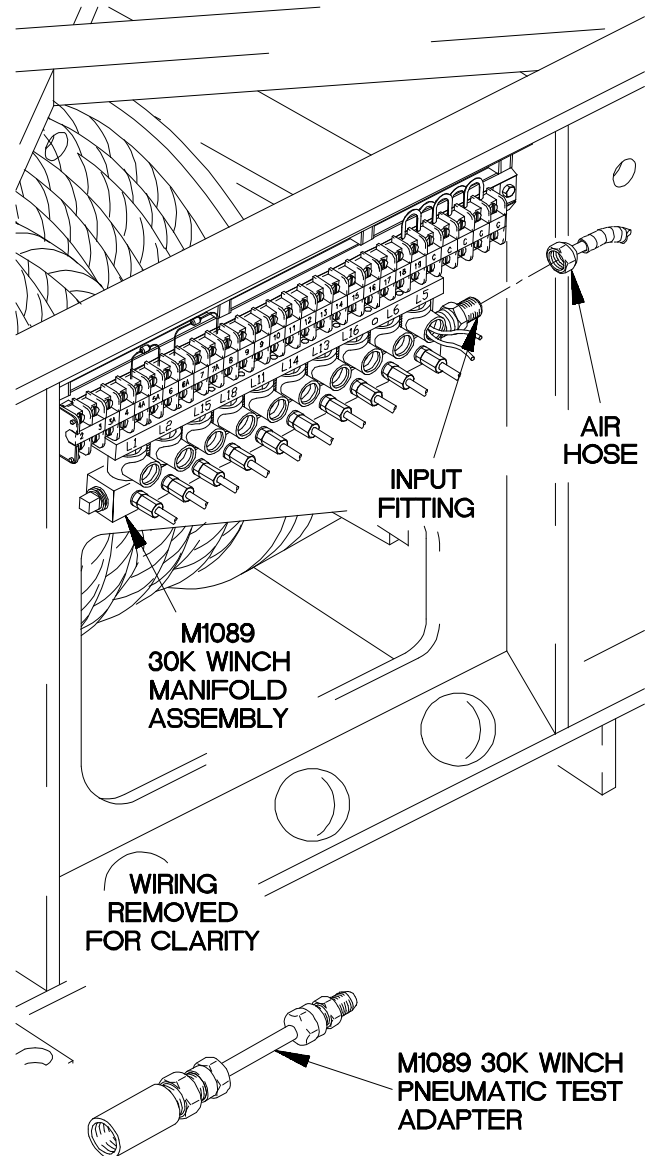

4BA403B

aa4. MAIN WINCH LH AND RH FREESPOOLS DO NOT OPERATE (CONT)

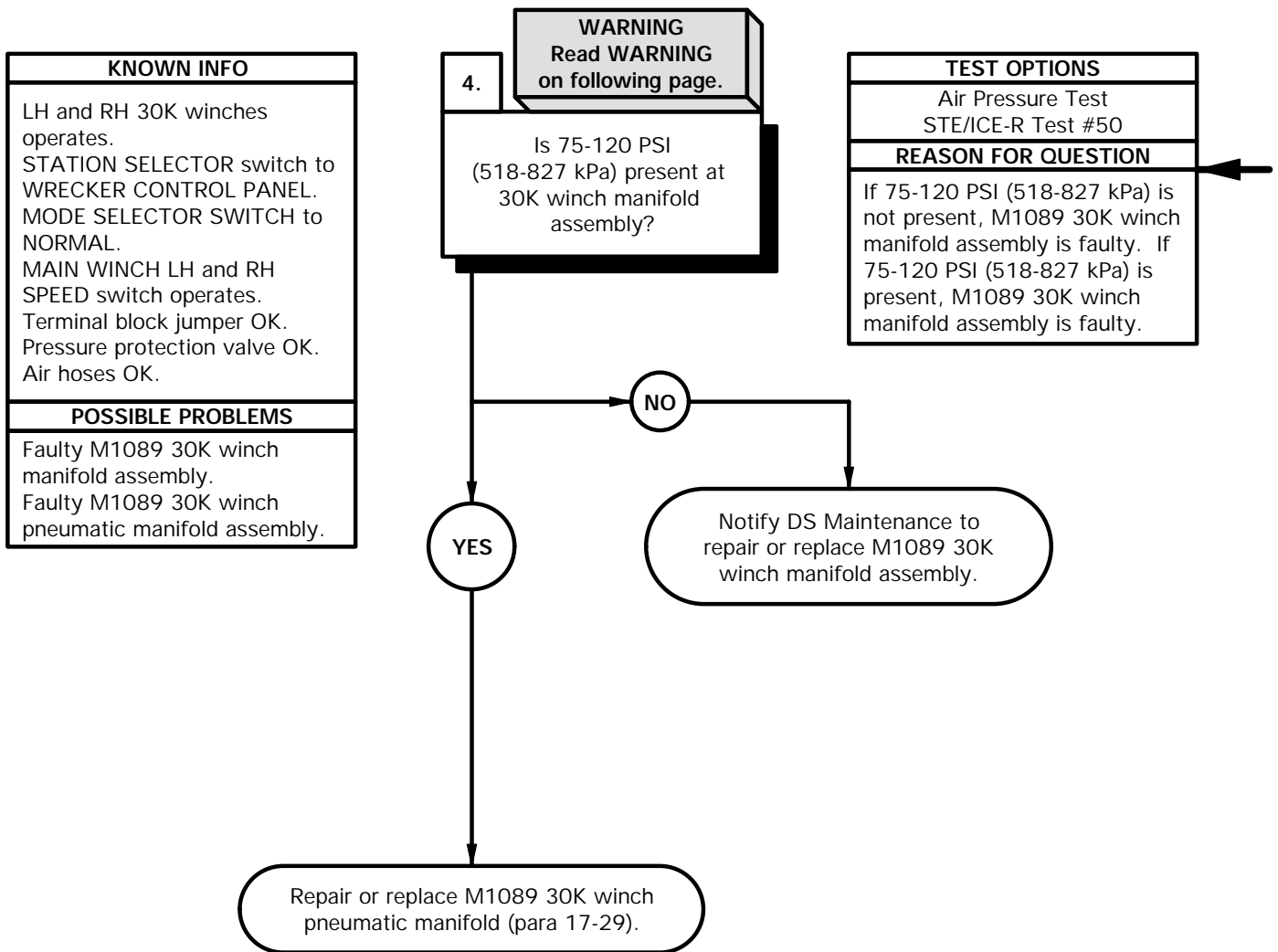

WARNING

Wear protective goggles to protect against possible injury from release of high pressure air. Failure to comply may result in injury to personnel.

NOTE

Tag air hose and connection point prior to disconnecting

AIR PRESSURE TEST STE/ICE-R TEST #50

- (1) Connect M1089 30K winch test adapter to input fitting.
- (2) Connect air hose to M1089 30K winch test adapter.
- (3) Install STE/ICE-R 0-1000 PSI transducer in M1089 30K winch test adapter.
- (4) Start engine (TM9-2320-366-10-1) and allow vehicle to build air pressure.
- (5) Perform STE/ICE-R Test #50 and note reading on STE/ICE-R.
- (6) If 75-120 PSI (518-827 kPa) is not present, notify DS Maintenance to repair or replace M1089 30K winch manifold assembly.
- (7) If 75-120 PSI (518-827 kPa) is present, repair or replace M1089 30K winch pneumatic manifold assembly (para 17-29).
- (8) Shut down engine (TM 902320-366-10-1).
- (9) Drain air tanks (TM9-2320-366-10-1).
- (10) Remove STE/ICE-R 0-1000 PSI transducer from M1089 30K winch test adapter.
- (11) Disconnect air hose from M1089 30K winch test adapter.
- (12) Disconnect M1089 30K winch test adapter from input fitting.
- (13) Connect air hose to input fitting on M1089 30K winch manifold assembly.
- (14) Close LH and RH catwalks.
- (15) Install wrecker control panel top cover (para 14-4).

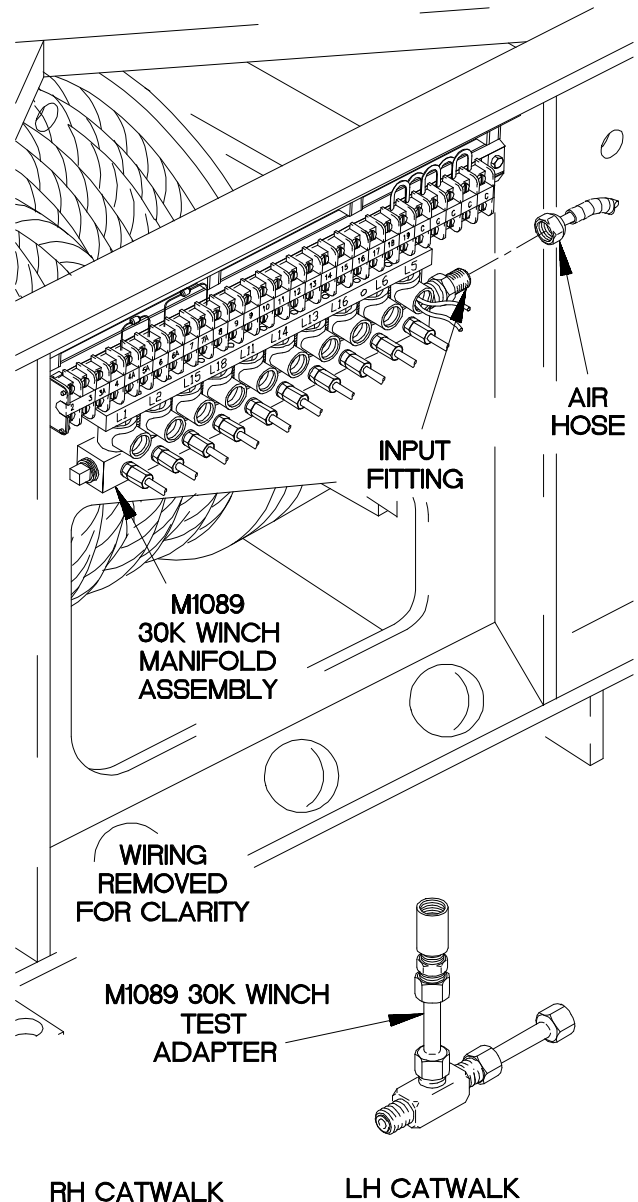

4BAA404B

aa4. MAIN WINCH LH AND RH FREESPOOLS DO NOT OPERATE (CONT)

KNOWN INFO
LH and RH 30K winches operates. STATION SELECTOR switch to WRECKER CONTROL PANEL. MODE SELECTOR SWITCH to NORMAL. MAIN WINCH LH and RH SPEED switch operates. Terminal block jumper OK.
POSSIBLE PROBLEMS
Faulty pressure protection valve. Faulty air hose.

5. **WARNING**
Read **WARNING** on following page.

Is 75-120 PSI (518-827 kPa) present at 90 degree fitting of pressure protection valve?

TEST OPTIONS
Air Pressure Test STE/ICE-R Test #50
REASON FOR QUESTION
If 75-120 PSI (518-827 kPa) is not present, pressure protection valve is faulty. If 75-120 PSI (518-827 kPa) is present, air hose is faulty.

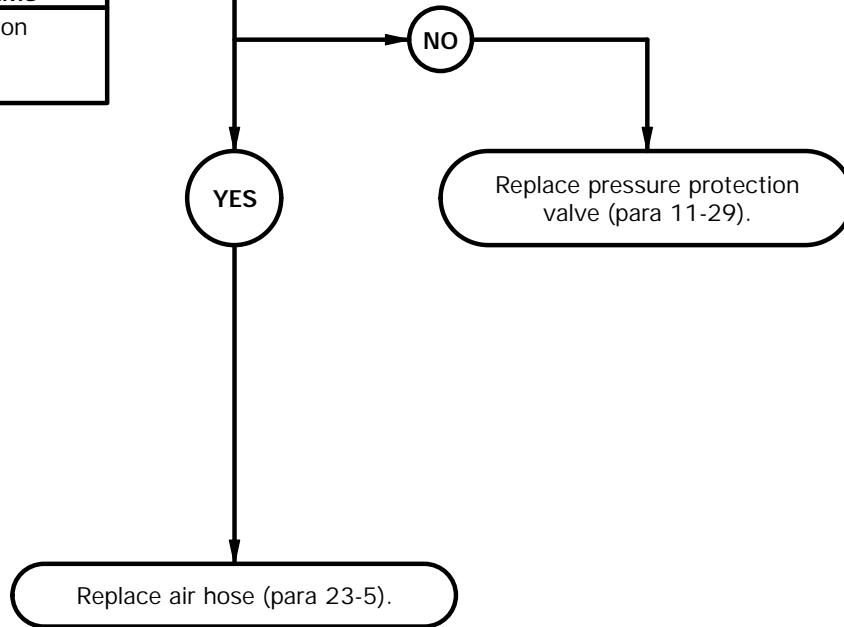

WARNING

Wear protective goggles to protect against possible injury from release of high pressure air. Failure to comply may result in injury to personnel.

NOTE

Tag air hose and connection point prior to disconnecting

AIR PRESSURE TEST STE/ICE-R TEST #50

- (1) Disconnect air hose from 90 degree fitting of pressure protection valve.
- (2) Remove tube nipple from M1089 30K winch pneumatic test adapter.
- (3) Connect M1089 30K winch pneumatic test adapter to 90 degree fitting of pressure protection valve.
- (4) Start engine (TM9-2320-366-10-1) and allow vehicle to build air pressure.
- (5) Perform STE/ICE-R Test #50 and note reading on STE/ICE-R.
- (6) If 75-120 PSI (518-827 kPa) is not present, replace pressure protection valve (para 11-29).
- (7) If 75-120 PSI (518-827 kPa) is present, replace air hose (para 23-5).
- (8) Shut down engine (TM 902320-366-10-1).
- (9) Drain air tanks (TM9-2320-366-10-1).
- (10) Remove STE/ICE-R 0-1000 PSI transducer from M1089 30K winch pneumatic test adapter.
- (11) Disconnect M1089 30K winch pneumatic test adapter from 90 degree fitting of pressure protection valve.
- (12) Connect air hose to 90 degree fitting of pressure protection valve.
- (13) Connect input air hose to input tee fitting.
- (14) Close LH and RH catwalks.
- (15) Install tube nipple on 30K winch pneumatic test adapter.

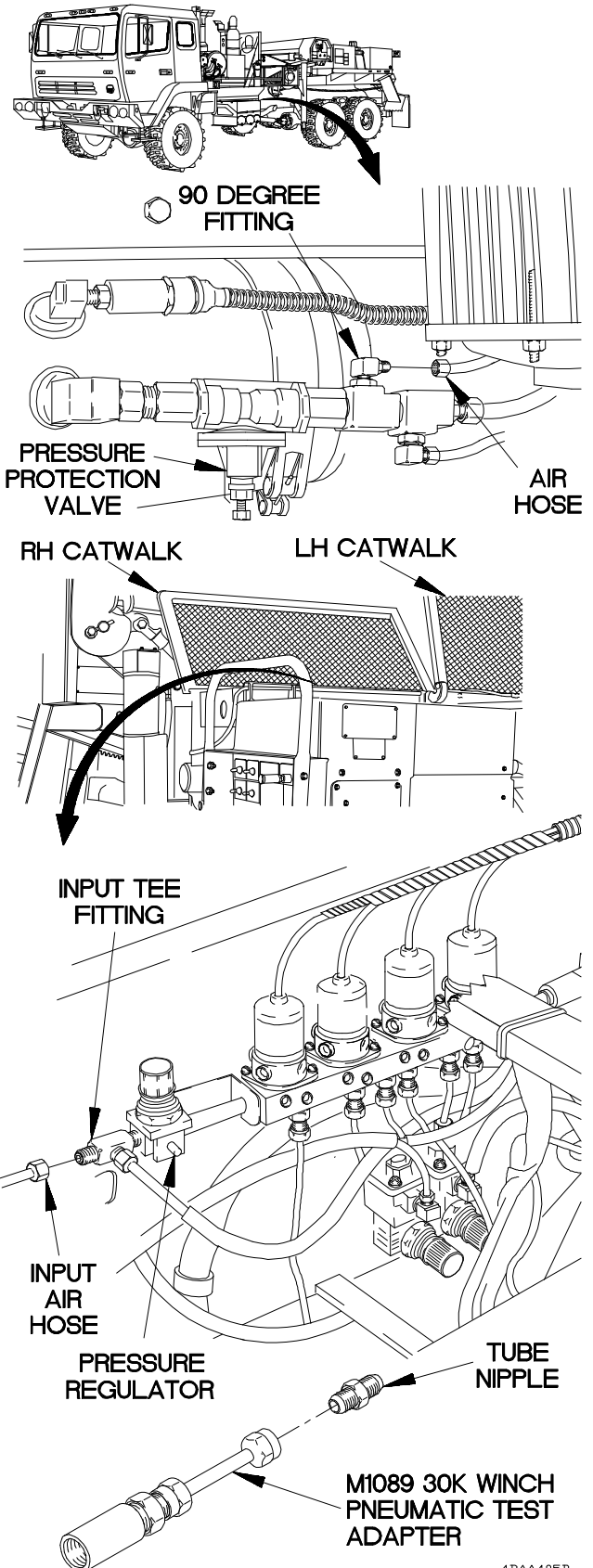

4BAA405B

aa5. M1089 LH OR RH 30K WINCH CABLE DRUM TENSIONER DOES NOT OPERATE

INITIAL SETUP

Equipment Conditions

Engine shut down (TM 9-2320-366-10-1).
 Air tanks drained (TM 9-2320-366-10-1).
 M1089 control panel covers removed (para 17-20)
 (RH side).

Personnel Required

(2)

References

TM 9-4910-571-12&P

Tools and Special Tools

Tool Kit, Genl Mech (Item 46, Appendix C)
 STE/ICE-R (Item 41, Appendix C)
 M1089 30K Winch Pneumatic Test Adapter
 (Item 25, Appendix E)
 Goggles, Industrial (Item 15, Appendix C)
 Nut, Self-Locking (2) (Item 133, Appendix G)
 Sealing Compound (Item 58, Appendix D)

NOTE

M1089 LH and RH 30K winch cable drum tensioners are tested the same way. LH side shown.

KNOWN INFO
Main winch LH/RH freespools.
POSSIBLE PROBLEMS
Faulty M1089 LH/RH 30K winch cable tensioner. Faulty 30K winch pneumatic manifold solenoid L8/L4. Faulty M1089 LH/RH 30K winch pneumatic valve assembly. Faulty air hose.

1. **WARNING**
 Read **WARNING** on following page.

Is 55-65 PSI (380-448 kPa) present at output 90 degree fitting of shuttle valve?

TEST OPTIONS
Air Pressure Test STE/ICE-R Test #50
REASON FOR QUESTION
This question eliminates possible problems and determines where troubleshooting continues.

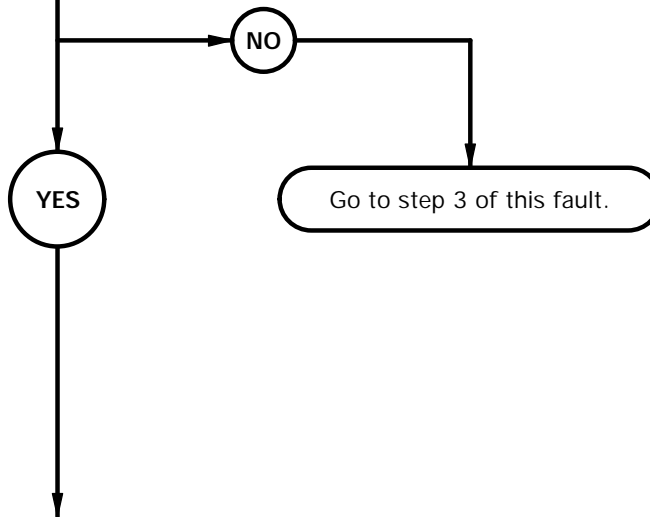

WARNING

Wear protective goggles to protect against possible injury from release of high pressure air. Failure to comply may result in injury to personnel.

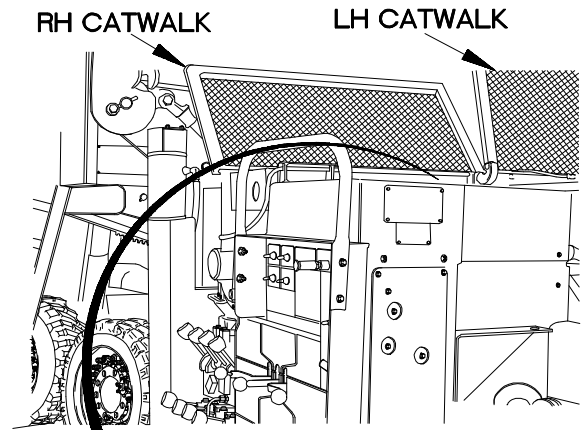

AIR PRESSURE TEST

- (1) Open LH and RH catwalks.
- (2) Disconnect air hose from output 90 degree fitting of shuttle valve.
- (3) Remove tube nipple from M1089 30K winch pneumatic test adapter.
- (4) Connect M1089 30K winch pneumatic test adapter to output 90 degree fitting of shuttle valve.
- (5) Install STE/ICE-R 0-1000 PSI transducer on M1089 30K winch pneumatic test adapter.
- (6) Start engine (TM 9-2320-366-10-1) and allow vehicle to build air pressure.
- (7) Perform STE/ICE-R Test #50 and note reading on STE/ICE-R.
- (8) If 55-65 PSI (340-448 kPa) is not present, go to step 3 of this fault.
- (9) Shut down engine (TM 9-2320-366-10-1).
- (10) Drain air tanks (TM9-2320-366-10-1).

NOTE

Air pressure trapped in wrecker air system will be released when disconnecting M1089 30K winch pneumatic test adapter from output 90 degree fitting.

- (11) Disconnect M1089 30K winch pneumatic test adapter from output 90 degree fitting of shuttle valve.
- (12) Connect air hose to output 90 degree fitting of shuttle valve.
- (13) Install tube nipple on M1089 30K winch pneumatic test adapter.

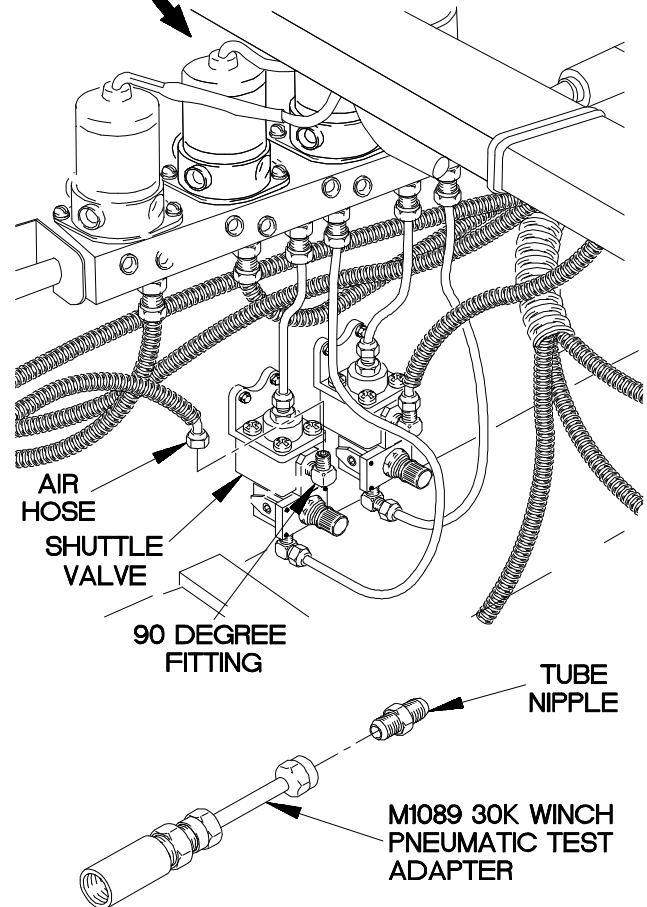

4BAA501B

aa5. M1089 LH OR RH 30K WINCH CABLE DRUM TENSIONER DOES NOT OPERATE (CONT)

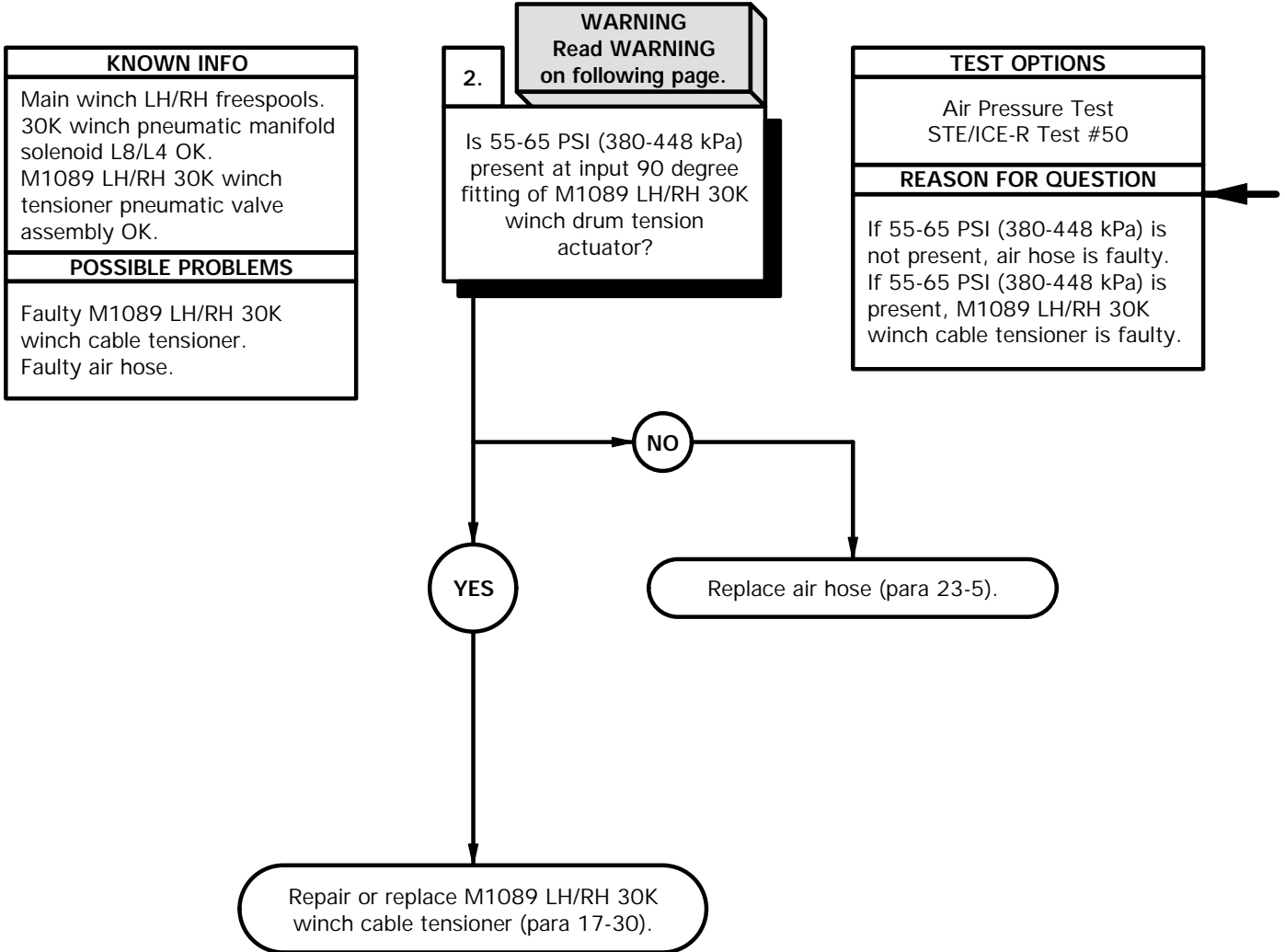

WARNING

Wear protective goggles to protect against possible injury from release of high pressure air. Failure to comply may result in injury to personnel.

AIR PRESSURE TEST

- (1) Disconnect air hose from input 90 degree fitting of M1089 LH/RH 30K winch drum tension actuator.
- (2) Connect air hose to M1089 30K winch pneumatic test adapter.
- (3) Start engine (TM 9-2320-366-10-1) and allow vehicle to build air pressure.
- (4) Perform STE/ICE-R Test #50 and note reading on STE/ICE-R.
- (5) If 55-65 PSI (380-448 kPa) is not present, replace air hose (para 23-5).
- (6) If 55-65 PSI (380-448 kPa) is present, repair or replace M1089 LH/RH 30K winch cable tensioner (para 17-30).
- (7) Shut down engine (TM 9-2320-366-10-1).
- (8) Drain air tanks (TM9-2320-366-10-1).

NOTE

Air pressure trapped in wrecker air system will be released when disconnecting air hose from M1089 30K winch pneumatic test adapter.

- (9) Disconnect air hose from M1089 30K winch pneumatic test adapter.
- (10) Connect air hose to input 90 degree fitting of M1089 LH/RH 30K winch drum tension actuator.
- (11) Close LH and RH catwalks.

NOTE

Perform step (12) for M1089 RH 30K winch cable drum tensioner.

- (12) Install M1089 control panel covers (para 17-20).

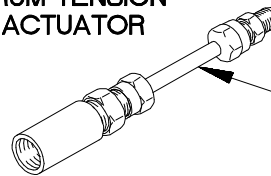
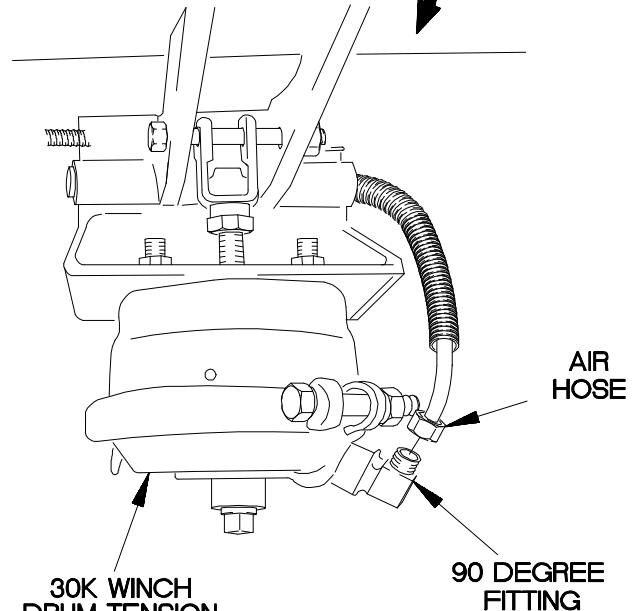

M1089 30K WINCH PNEUMATIC TEST ADAPTER

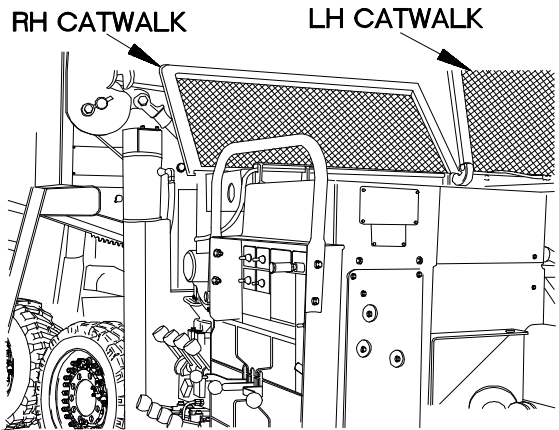

4BA502B

aa5. M1089 LH OR RH 30K WINCH CABLE DRUM TENSIONER DOES NOT OPERATE (CONT)

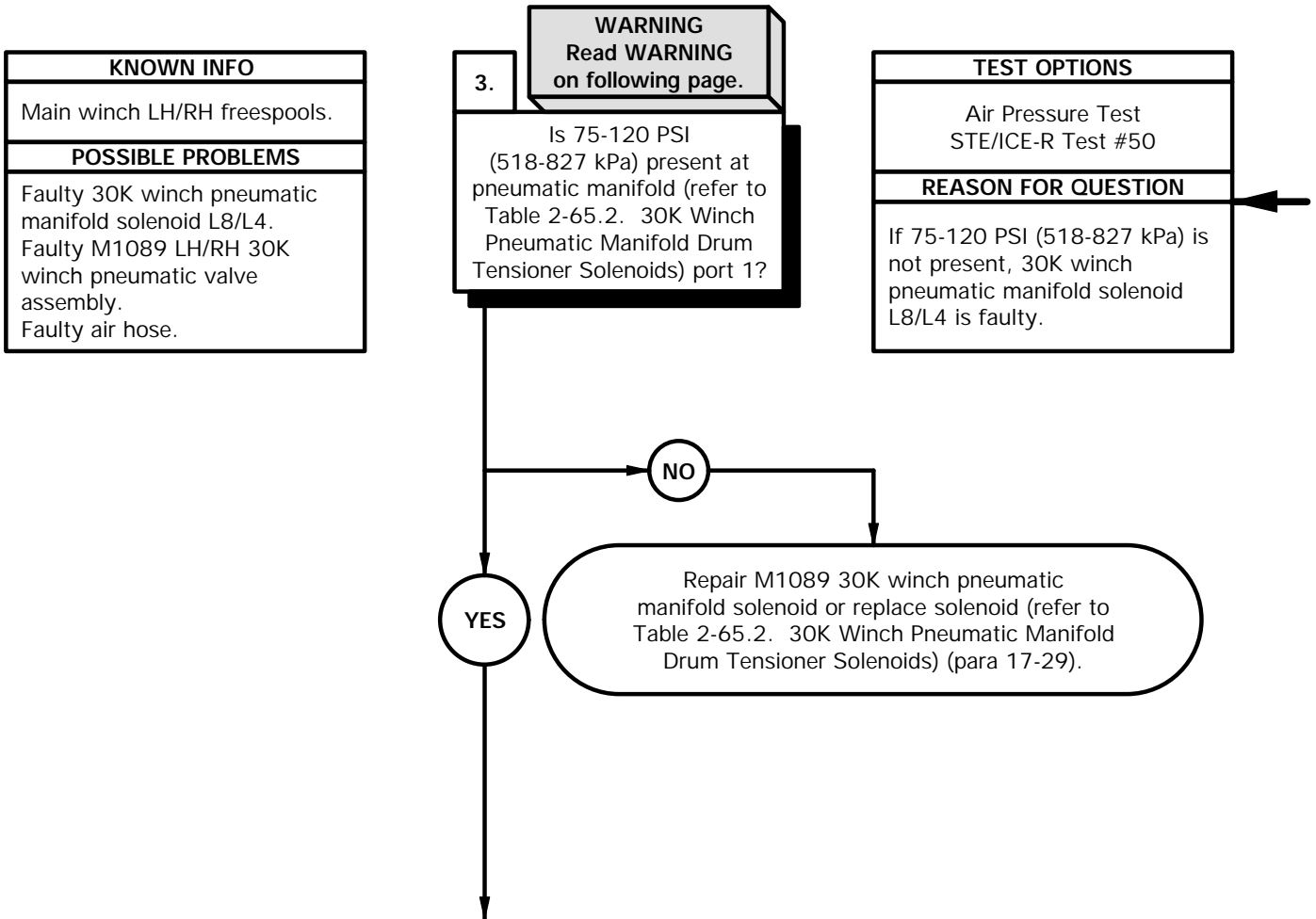

WARNING

Wear protective goggles to protect against possible injury from release of high pressure air. Failure to comply may result in injury to personnel.

AIR PRESSURE TEST

- (1) Disconnect air hose from pneumatic manifold (refer to Table 2-65.2. 30K Winch Pneumatic Manifold Drum Tensioner Solenoids) solenoid port 1.
- (2) Remove tube nipple from M1089 30K winch pneumatic test adapter.
- (3) Connect M1089 30K winch pneumatic test adapter to pneumatic manifold (refer to Table 2-65.2. 30K Winch Pneumatic Manifold Drum Tensioner Solenoids) solenoid port 1.
- (4) Start engine (TM 9-2320-366-10-1) and allow vehicle to build air pressure.
- (5) Perform STE/ICE-R Test #50 and note reading on STE/ICE-R.
- (6) If 75-120 PSI (518-827 kPa) is not present, repair M1089 30K winch pneumatic manifold solenoid or replace solenoid (refer to Table 2-65.2. 30K Winch Pneumatic Manifold Drum Tensioner Solenoids) (para 17-29).
- (7) Shut down engine (TM 9-2320-366-10-1).
- (8) Drain air tanks (TM9-2320-366-10-1).

NOTE

Air pressure trapped in wrecker air system will be released when disconnecting M1089 30K winch pneumatic test adapter from solenoid port 1.

- (9) Disconnect M1089 30K winch pneumatic test adapter from pneumatic manifold (refer to Table 2-65.2. 30K Winch Pneumatic Manifold Drum Tensioner Solenoids) solenoid port 1.
- (10) Connect air hose to pneumatic manifold (refer to Table 2-65.2. 30K Winch Pneumatic Manifold Drum Tensioner Solenoids) solenoid port 1.
- (11) Install tube nipple on M1089 30K winch pneumatic test adapter.

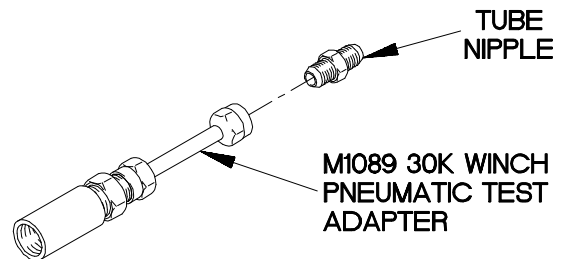
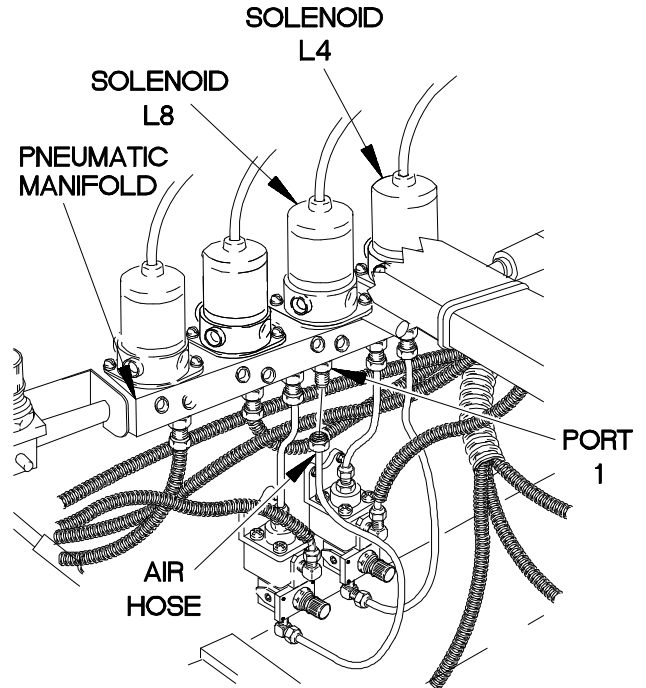

4ba.a503b

Table 2-65.2. 30K Winch Pneumatic Manifold Drum Tensioner Solenoids

Side	Solenoid
LH	L8
RH	L4

aa5. M1089 LH OR RH 30K WINCH CABLE DRUM TENSIONER DOES NOT OPERATE (CONT)

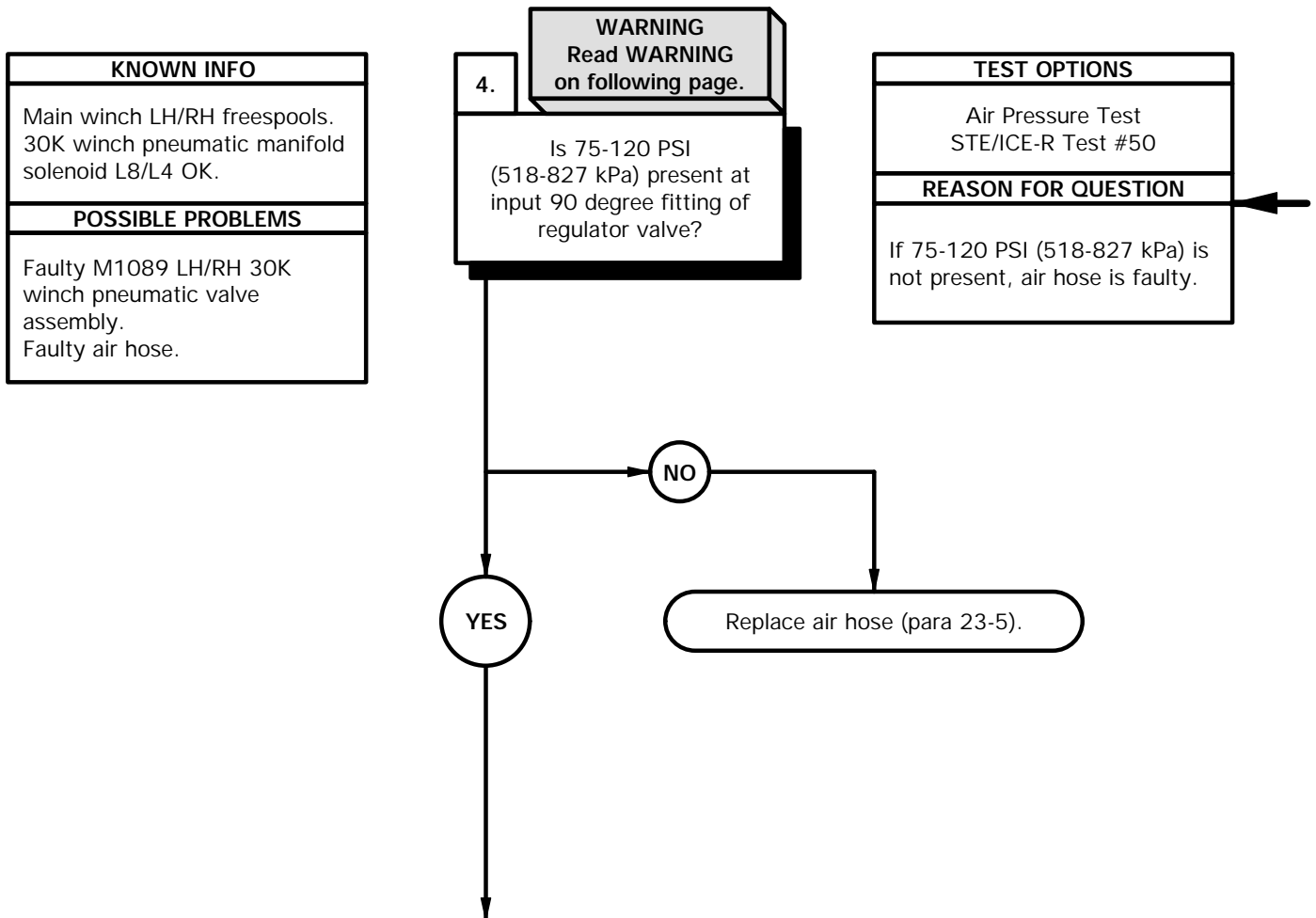

WARNING

Wear protective goggles to protect against possible injury from release of high pressure air. Failure to comply may result in injury to personnel.

AIR PRESSURE TEST

NOTE

Tag air hose and connection point prior to disconnecting.

- (1) Disconnect input air hose from input 90 degree fitting of regulator valve.
- (2) Connect input air hose to M1089 30K winch pneumatic test adapter.
- (3) Start engine (TM 9-2320-366-10-1) and allow vehicle to build air pressure.
- (4) Perform STE/ICE-R Test #50 and note reading on STE/ICE-R.
- (5) If 75-120 PSI (518-827 kPa) is not present, replace air hose (para 23-5).
- (6) Shut down engine (TM 9-2320-366-10-1).
- (7) Drain air tanks (TM9-2320-366-10-1).

NOTE

Air pressure trapped in wrecker air system will be released when disconnecting input air hose from M1089 30K winch pneumatic test adapter.

- (8) Disconnect input air hose from M1089 30K winch pneumatic test adapter.
- (9) Remove STE/ICE-R 0-1000 PSI transducer from M1089 30K winch pneumatic test adapter.

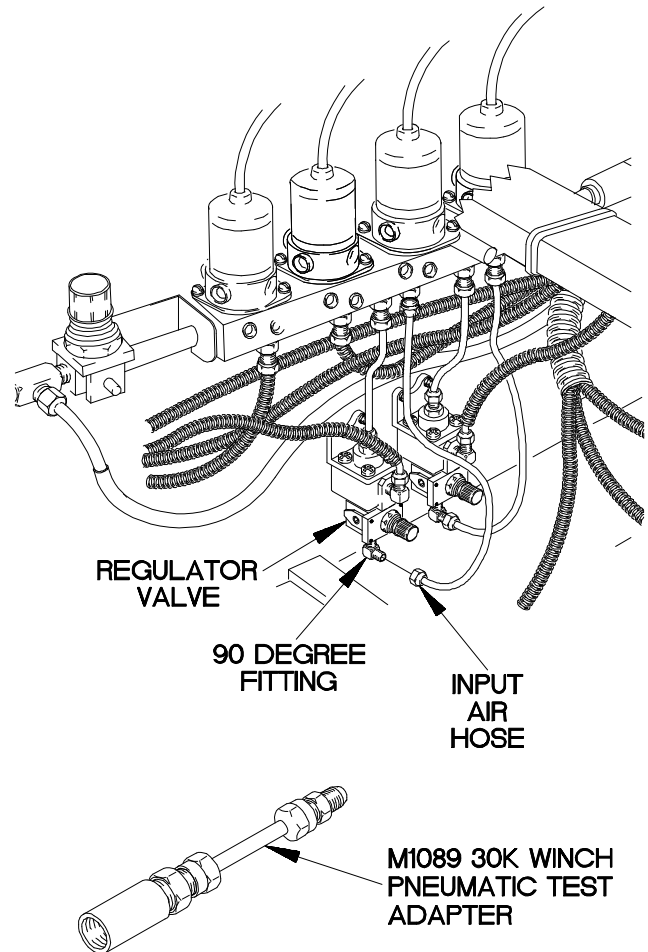

4ba.a.504b

aa5. M1089 LH OR RH 30K WINCH CABLE DRUM TENSIONER DOES NOT OPERATE (CONT)

KNOWN INFO
Main winch LH/RH freespools. 30K winch pneumatic manifold solenoid L8/L4 OK. Air hoses OK.
POSSIBLE PROBLEMS
Faulty M1089 LH/RH 30K winch pneumatic valve assembly.

5.
Is 55-65 PSI (380-440 kPa) present at output 90 degree fitting of regulator valve?

TEST OPTIONS
Air Pressure Test STE/ICE-R Test #50
REASON FOR QUESTION
If 55-65 PSI (380-440 kPa) is not present, regulator valve is faulty. If 55-65 PSI (380-440 kPa) is present, shuttle valve is faulty.

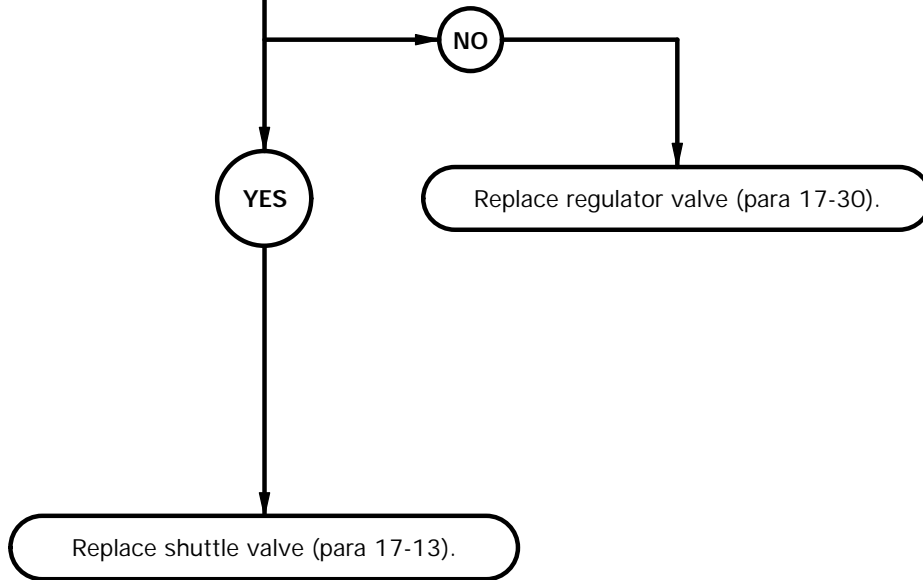

AIR PRESSURE TEST

NOTE

Tag air hoses and connection points prior to disconnecting.

- (1) Disconnect air hose from adapter fitting on shuttle valve.
- (2) Disconnect air hose from 90 degree fitting on shuttle valve.
- (3) Remove two self-locking nuts, washers, screws, and shuttle valve from bulkhead. Discard self-locking nuts.
- (4) Position shuttle valve in vise.
- (5) Remove regulator valve from pipe nipple.
- (6) Install STE/ICE-R 0-1000 PSI pressure transducer in output port of regulator valve.
- (7) Connect input air hose to input 90 degree fitting of regulator valve.
- (8) Start engine (TM 9-2320-366-10-1) and allow vehicle to build air pressure.
- (9) Perform STE/ICE-R Test #50 and note reading on STE/ICE-R.
- (10) If 55-65 PSI (380-440 kPa) is not present, perform step (18) through (22).
- (11) If 55-65 PSI (380-440 kPa) is present, replace shuttle valve (para 17-30).
- (12) Shut down engine (TM 9-2320-366-10-1).
- (13) Drain air tanks (TM 9-2320-366-10-1).
- (14) Disconnect input air hose from output 90 degree fitting of regulator valve.
- (15) Remove STE/ICE-R 0-1000 PSI transducer from output port of regulator valve.
- (16) Close LH and RH catwalks.

NOTE

Perform step (17) for M1089 RH 30K winch cable drum tensioner.

- (17) Install M1089 control panel covers (para 17-20).
- (18) Pull out and turn knob on regulator valve fully counter clockwise.
- (19) Pull out and turn knob on regulator valve clockwise until STE/ICE-R shows between 55-65 PSI (380-440 kPa).
- (20) If 55-65 PSI (380-440 kPa) is present after adjustment, perform steps (23) through (30).
- (21) If 55-65 PSI (380-440 kPa) is still not present after adjustment, replace regulator valve (para 17-30).
- (22) Perform steps (12) through (17).
- (23) Shut down engine (TM 9-2320-366-10-1).
- (24) Drain air tanks (TM 9-2320-366-10-1).
- (25) Disconnect input air hose from input 90 degree fitting of regulator valve.

AIR PRESSURE TEST (Cont)

- (26) Remove STE/ICE-R 0-1000 PSI transducer from output port of regulator valve.
- (27) Apply sealing compound to threads of pipe nipple.
- (28) Install regulating valve on pipe nipple.
- (29) Install 30K winch tension Pneumatic valve assembly (para 17-30).
- (30) Close LH and RH catwalks.

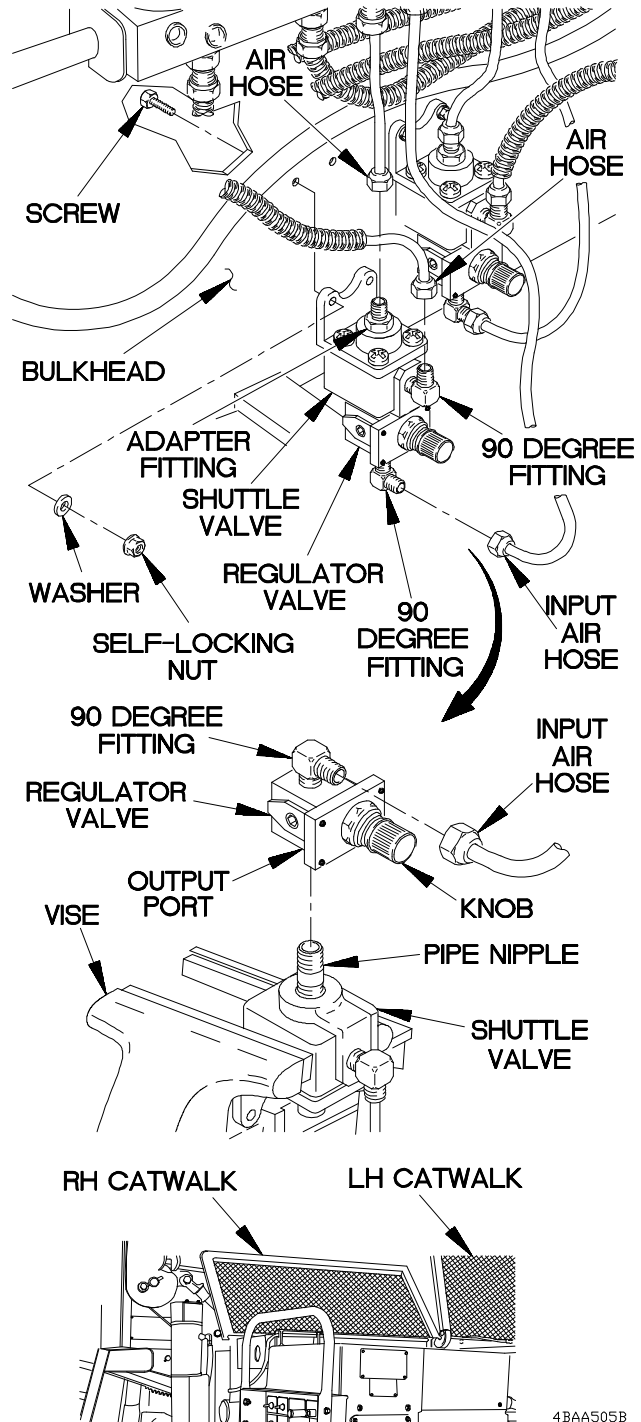

4BAA505B

aa6. ONE WRECKER FUNCTION DOES NOT OPERATE FROM WRECKER REMOTE CONTROL

INITIAL SETUP

Equipment Conditions

Engine shut down (TM 9-2320-366-10-1).
 Top control panel cover removed (para 17-20).
 Front middle and lower panel covers removed (para 17-20).
 Air tanks drained (TM 9-2320-366-10-1).

Tools and Special Tools

Tool Kit, Genl Mech (Item 46, Appendix C)
 STE/ICE-R (Item 41, Appendix C)
 Multimeter, Digital (Item 22, Appendix C)
 M1089 Solenoid Test Adapter (Item 8, Appendix E)
 Goggles, Industrial (Item 15, Appendix C)

Personnel Required

(2)

References

TM 9-4910-571-12&P

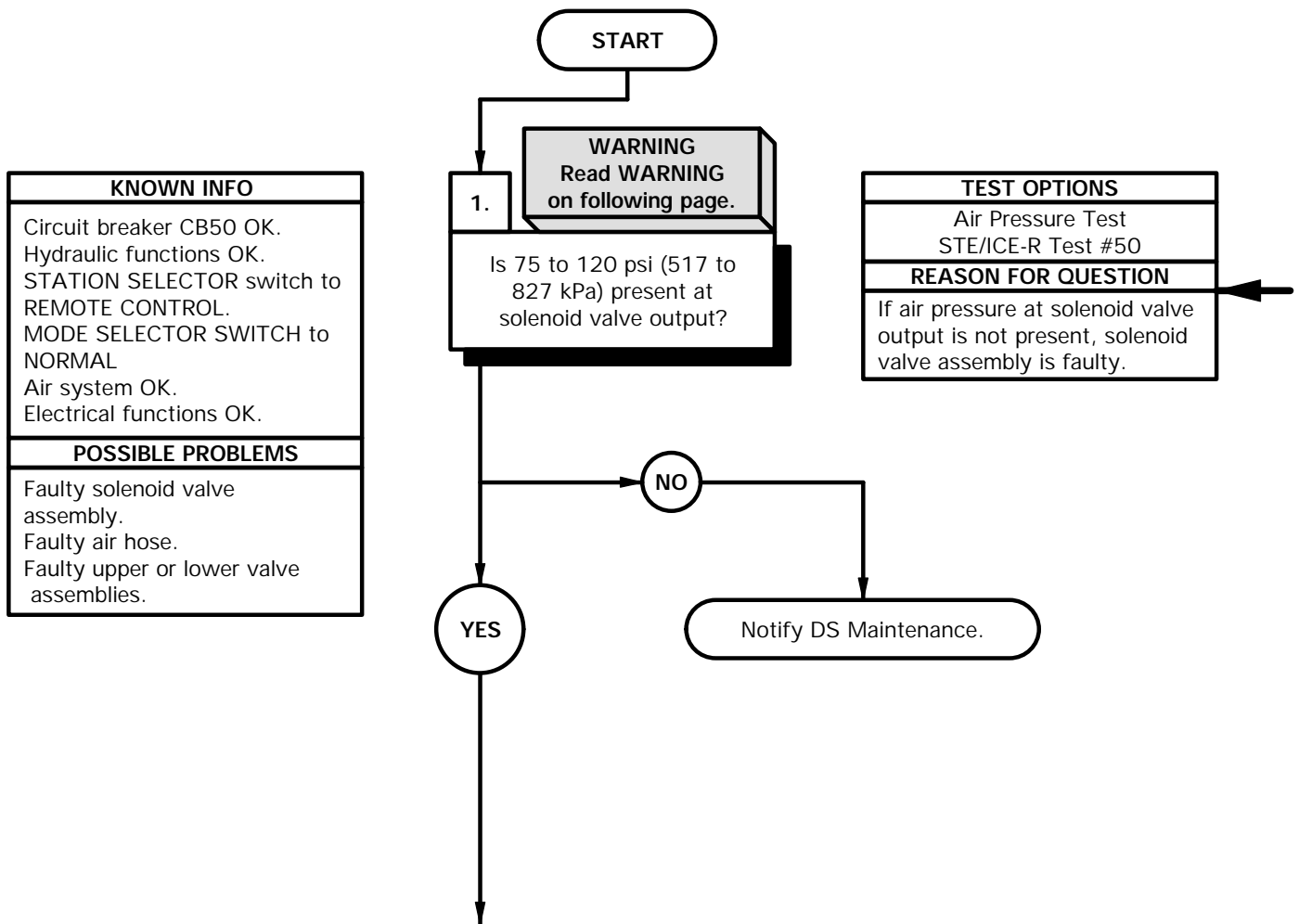

WARNING

Wear protective goggles to protect against possible injury from release of high pressure air. Failure to comply may result in injury to personnel.

NOTE

Tag air hose and connection point prior to disconnecting.

AIR PRESSURE TEST STE/ICE-R TEST #50

- (1) Disconnect air hose from solenoid valve listed in Table 2-66. Wrecker Function Solenoid Valves and Actuators.
- (2) Install test adapter on solenoid valve.
- (3) Install STE/ICE-R 0-1000 psi transducer on test adapter.
- (4) Start engine (TM 9-2320-366-10-1).
- (5) Position WRECKER REMOTE CONTROL switch listed in Table 2-66. Wrecker Function Solenoid Valve.
- (6) Perform STE/ICE-R Test #50 and note reading on STE/ICE-R.
- (7) If 75 to 120 psi (517 to 827 kPa) is not present, notify DS Maintenance.
- (8) Shut down engine (TM 9-2320-366-10-1).
- (9) Drain air tanks (TM 9-2320-366-10-1).
- (10) Remove STE/ICE-R and test adapter from solenoid valve.
- (11) Install air hose on solenoid valve.

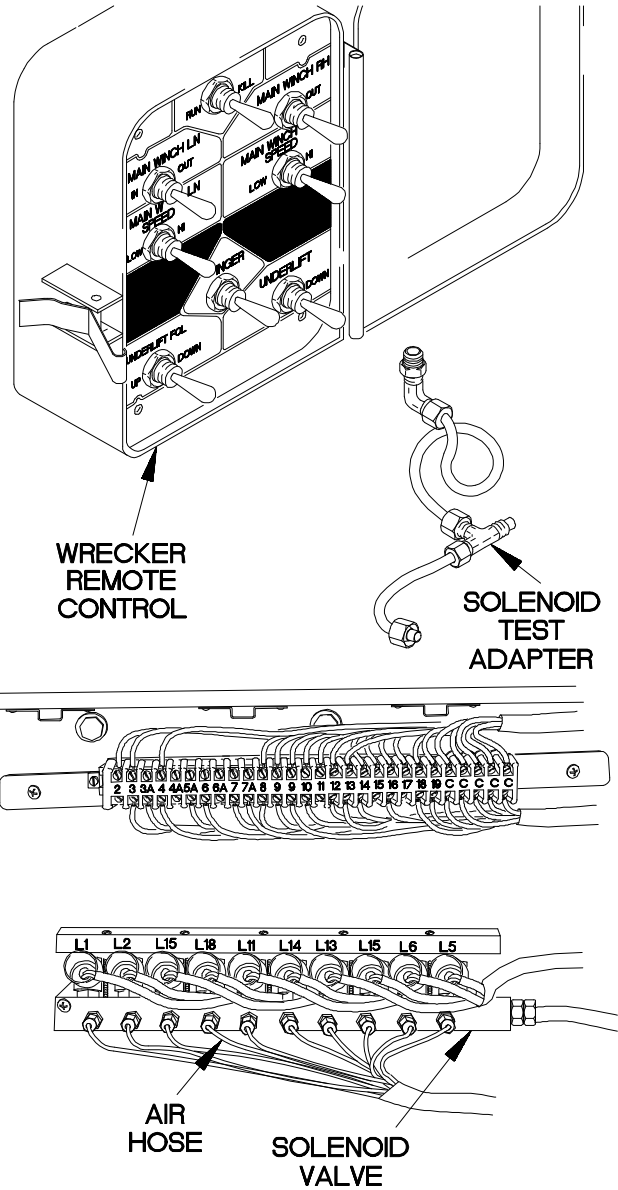

4B0a101b

Table 2-66. Wrecker Function Solenoid Valves and Actuators

Function	Wrecker Remote Control Switch Position	Actuator and Solenoid Valve	Upper or Lower Valve Actuator Air Hose Position
Underlift Fold Up	Up	L18	Lower Front
Underlift Fold Down	Down	L15	Lower Rear
Stinger In	In	L16	Lower Front
Stinger Out	Out	L13	Lower Rear
Underlift Up	Up	L14	Lower Front
Underlift Down	Down	L11	Lower Rear
Main Winch LH In	In	L6	Upper Front
Main Winch LH Out	Out	L5	Upper Rear
Main Winch RH In	In	L2	Lower Front
Main Winch RH Out	Out	L1	Lower Rear

aa6. ONE WRECKER FUNCTION DOES NOT OPERATE FROM WRECKER REMOTE CONTROL (CONT)

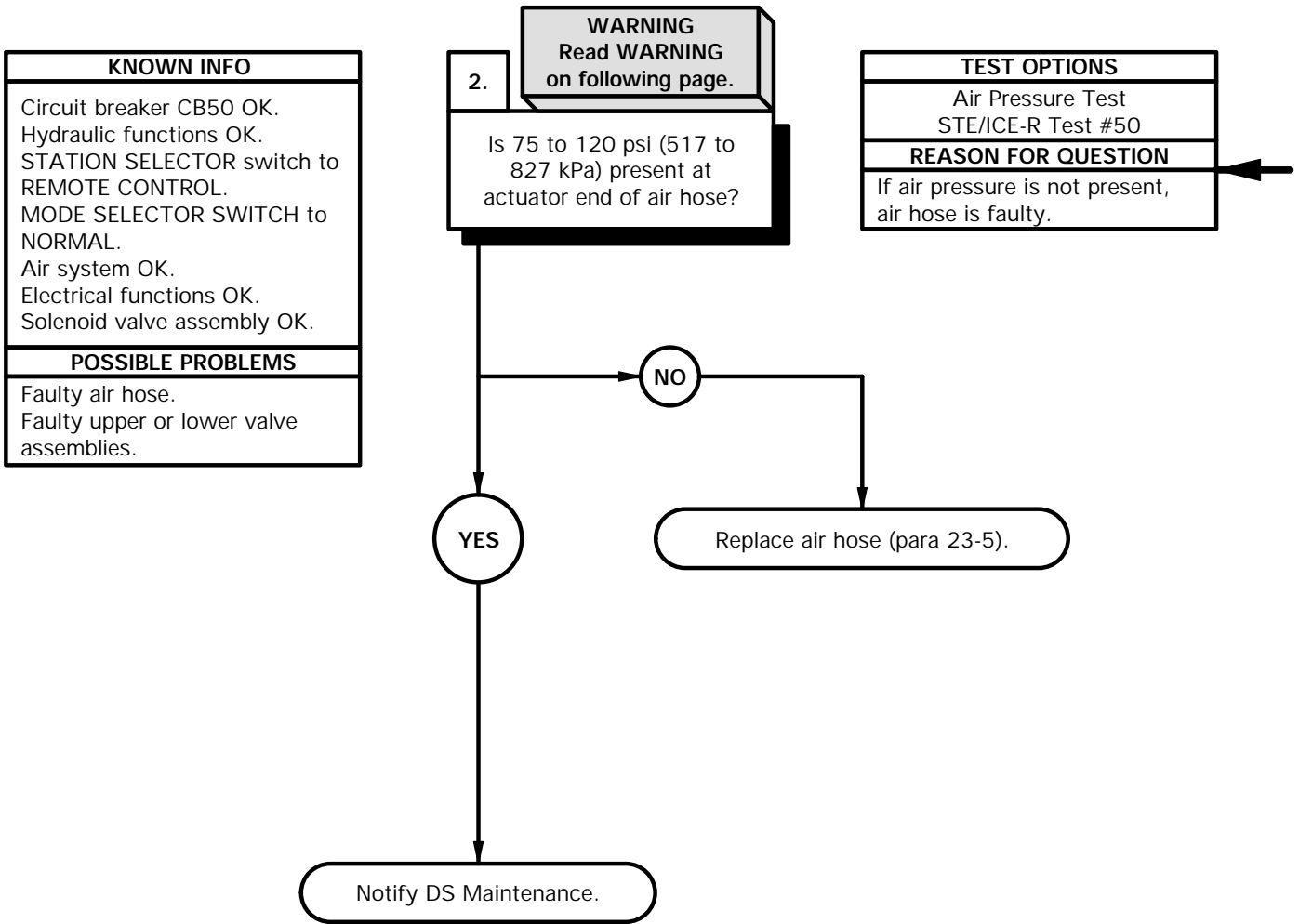

WARNING

Wear protective goggles to protect against possible injury from release of high pressure air. Failure to comply may result in injury to personnel.

NOTE

Tag air hose and connection point prior to disconnecting.

AIR PRESSURE TEST STE/ICE-R TEST #50

- (1) Disconnect air hose from actuator listed in Table 2-66. Wrecker Function Solenoid Valves and Actuators.
- (2) Install test adapter on solenoid valve.
- (3) Install STE/ICE-R 0-1000 psi transducer on test adapter.
- (4) Start engine (TM 9-2320-366-10-1).
- (5) Position WRECKER REMOTE CONTROL switch listed in Table 2-67. Wrecker Function Actuator.
- (6) Perform STE/ICE-R Test #50 and note reading on STE/ICE-R.
- (7) If 75 to 120 psi (517 to 827 kPa) is not present, replace air hose (para 23-5).
- (8) If 75 to 120 psi (517 to 827 kPa) is present, notify DS Maintenance.
- (9) Shut down engine (TM 9-2320-366-10-1).
- (10) Drain air tanks (TM 9-2320-366-10-1).
- (11) Remove STE/ICE-R and test adapter from solenoid valve.
- (12) Install air hose on actuator.
- (13) Install front middle and lower panel covers (para 17-20).
- (14) Install top control panel cover (para 17-20).

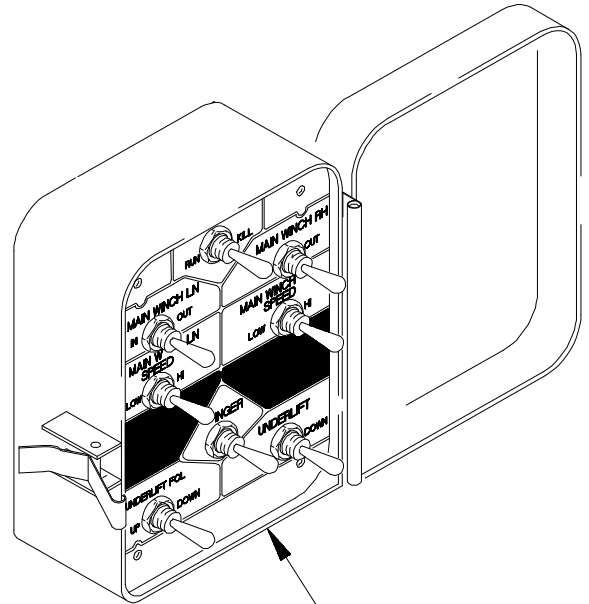

WRECKER REMOTE CONTROL

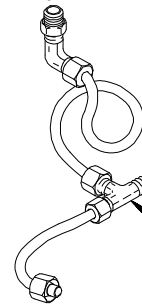

SOLENOID TEST ADAPTER

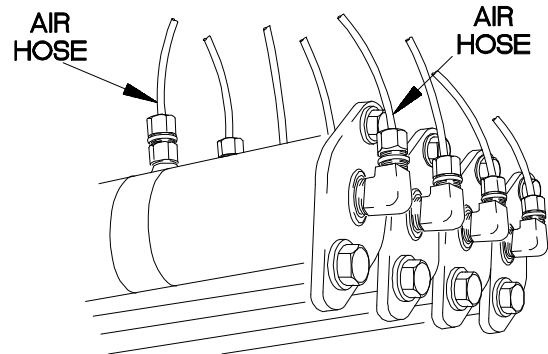

AIR HOSE

AIR HOSE

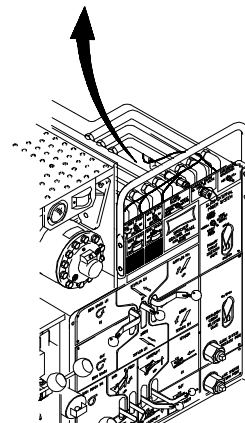

4B a.102b

2-38. FRAME TROUBLESHOOTING

This paragraph covers Frame Troubleshooting. The Frame Fault Index, Table 2-68, lists faults for the frame of the vehicle.

Table 2-68. Frame Fault Index

Fault No.	Description	Page
ab1.	Tires Continue to Wear After Front End Alignment and/or Vehicle Drives Sideways Down Road	2-2436

ab1. TIRES CONTINUE TO WEAR AFTER FRONT END ALIGNMENT AND/OR VEHICLE DRIVES SIDWAYS DOWN ROAD	
INITIAL SETUP	
Equipment Conditions Engine shut down (TM 9-2320-366-10-1).	Tools and Special Tools Tool Kit, Genl Mech (Item 46, Appendix C)
Personnel Required (4)	

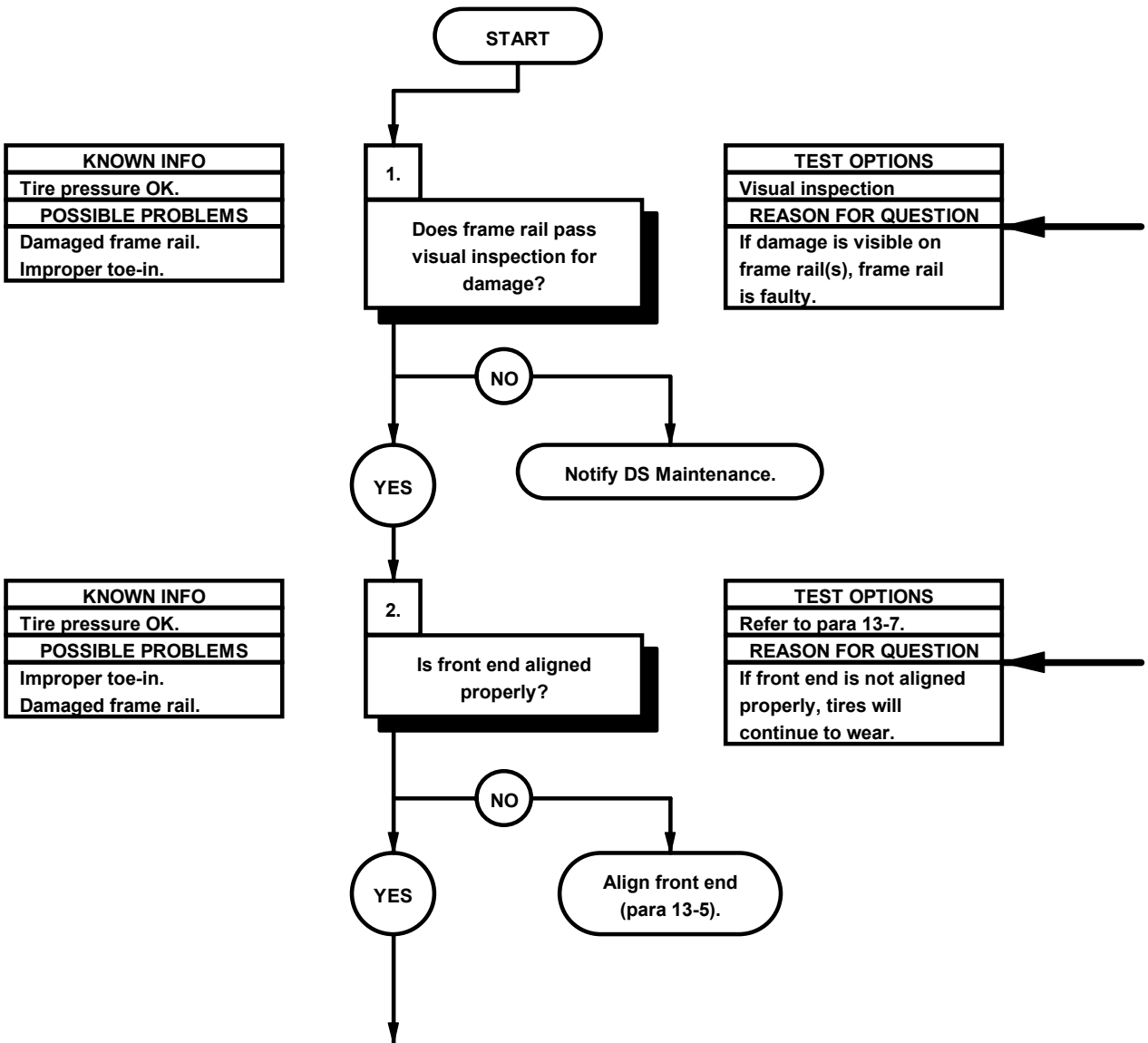

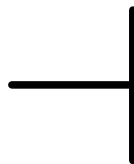

Inspect frame rails and cross members for visible damage. If frame rail(s) and/or cross member(s) show any evidence of damage or bends, notify DS Maintenance.

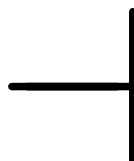

Perform front end alignment and verify proper toe-in (para 13-5).

ab1. TIRES CONTINUE TO WEAR AFTER FRONT END ALIGNMENT AND/OR VEHICLE DRIVES SIDWAYS DOWN ROAD (CONT)

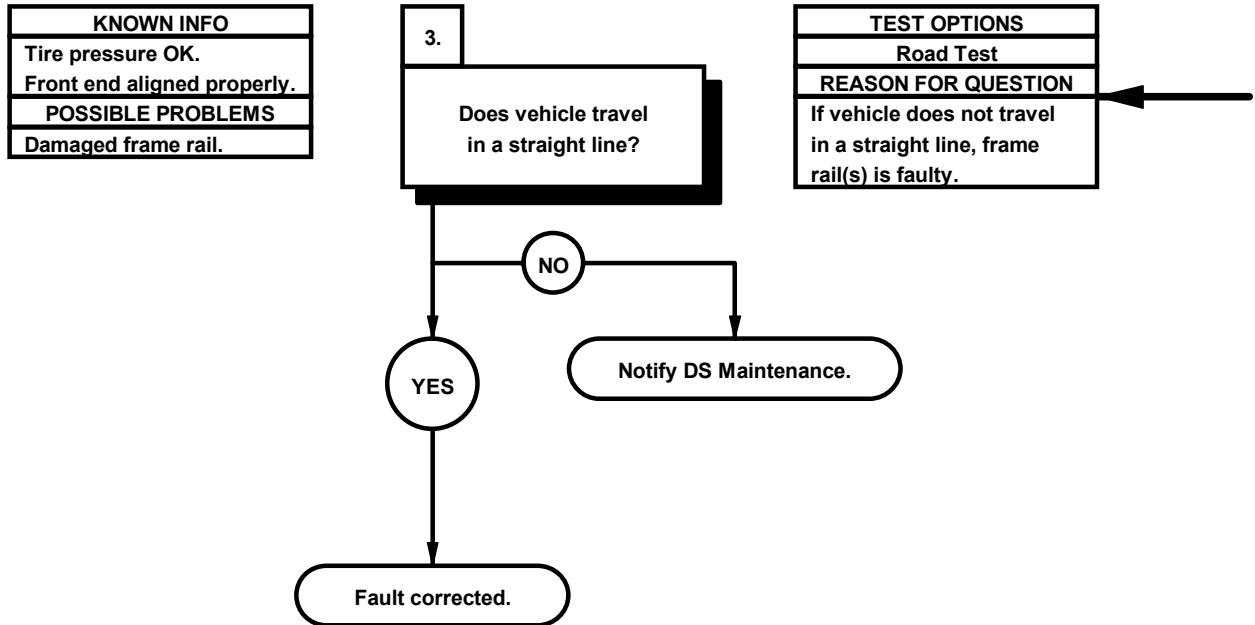

ROAD TEST

- (1) Road test vehicle with additional vehicle following.
- (2) Have following vehicle monitor path of lead vehicle.
- (3) If front of vehicle can be seen while in direct line of rear of vehicle, notify DS Maintenance.

Section V. MAINTENANCE PROCEDURES

2-39. MAINTENANCE INTRODUCTION

This section provides general procedures to be followed for the Unit Maintenance level as specified in the Maintenance Allocation Chart (MAC). When a special procedure is used, the detailed procedure will be in the section covering that component.

2-40. GROUND HANDLING

- a. **Towing.** Two towing eyes are located at front and two located at rear of vehicle.
- b. **Parking.** Parking brakes are designed to hold GVW on a minimum of 7-9 percent grade, pointing either uphill or downhill per Federal Motor Carrier Safety Regulation 393.41.
- c. **Mooring and Transporting.** For forward, aft, lateral and upward movements, vehicle has four tiedown rings. Refer to TM 9-2320-366-10-2 for mooring condition and tiedown locations.
- d. **Hoisting.** Sling assemblies and towing eyes used for hoisting are found on the vehicle.

2-41. GENERAL REMOVAL INSTRUCTIONS

- a. **Work Required.** Remove parts if repair or replacement is required. Do not disassemble a component any further than needed.
- b. **Preparation.** Before removal of any electrical, hydraulic, or air system components, ensure system component is not energized or pressurized. Disconnect battery ground cables. Relieve air system pressure. Before removal of fasteners (nuts, locknuts) remove any paint on threads to prevent binding of fastener.
- c. **Identification.** To ease assembly and installation, tag and mark shims, connectors, wires and mating ends of lines before disconnecting them. Identify similar parts to ensure correct assembly.
- d. **Position of Valves.** Before removing valve handles, mark or diagram their positions when open and closed. This will help during assembly.
- e. **Tire Removal.** Before removing any tires, position jackstands under axles, walking beams or frame. This will secure the vehicle for safe tire removal.
- f. **Location.** Before removing cable ties, cushion clamps, hoses, tubing, wiring, etc., note the location, position and routing to ensure correct assembly.

2-41. GENERAL REMOVAL INSTRUCTIONS (CONT)

g. Data Plate Removal.

WARNING

Wear appropriate eye protection when removing rivets. Failure to comply may result in injury to personnel.

CAUTION

Use appropriate size drill bit when removing rivets. Failure to comply may cause damage to equipment.

Remove rivets and data plate from vehicle.

h. Rivnut Removal.

WARNING

Wear appropriate eye protection when removing rivets. Failure to comply may result in injury to personnel.

CAUTION

Use appropriate size drill bit when removing rivets. Failure to comply may cause damage to equipment.

Remove rivets and rivnut from vehicle.

2-42. GENERAL DISASSEMBLY INSTRUCTIONS

a. Cleanliness. Work area must be as clean as possible to prevent contamination to components.

CAUTION

Self-locking fasteners that are loosened must be replaced, not tightened.

b. Locking Parts. Replace all lockwashers, cotter pins and self-locking nuts at time of reassembly.

c. Expendable Parts. All gaskets, packings, and seals removed during repair must be discarded and replaced with new parts.

d. Removing Seals. Be sure all traces of oil, gaskets, and sealants are removed from components. When possible, use wood or plastic probes and scrapers to prevent damage to machined surfaces.

CAUTION

Do not use tape to close off fuel or oil openings. Sticky surface of tape can mix with fuel and oil and cause engine malfunctions.

e. Parts Protection. To keep dust, dirt, moisture, and other objects out of internal parts of systems or components, cap or tape all open tubes, hoses, air lines, fittings and component openings as soon as part is removed. Wrap all removed parts in clean paper or dip parts in preservation oil.

2-43. GENERAL CLEANING INSTRUCTIONS**WARNING**

- **Dry Cleaning Solvent (P-D-680) is TOXIC and flammable. Wear protective goggles and gloves; use only in well ventilated area; avoid contact with skin, eyes, and clothes, and do not breathe vapors. Keep away from heat or flame. Never smoke when using solvent; the flashpoint for Type I Dry Cleaning Solvent is 100 degrees F (38 degrees C) and for Type II is 130 degrees F (50 degrees C). Failure to comply may result in serious injury or death to personnel.**
- **If personnel become dizzy while using Dry Cleaning Solvent, immediately get fresh air and medical help. If solvent contacts skin or clothes, flush with cold water. If solvent contacts eyes, immediately flush eyes with water and get immediate medical attention. Failure to comply may result in injury to personnel.**
- **Never use fuel to clean parts. Fuel is highly flammable. Serious injury or death could result if fuel ignites during cleaning.**

a. Cleaning Solvents. Use only approved cleaning solvents to clean parts. Dry Cleaning Solvent P-D-680 (Item 65, Appendix D) is commonly used. Always work in a well-ventilated area.

WARNING

Compressed air used for cleaning purposes will not exceed 30 psi (207 kPa). Use only with effective chip guarding and personal protective equipment (goggles/shield, gloves, etc). Failure to comply may result in injury to personnel.

b. Removing Deposits. Soak parts in Dry Cleaning Solvent P-D-680 (Item 65, Appendix D), and wash away deposits by flushing or spraying. When necessary, brush with a soft bristle brush (not wire) moistened in solvent. Use compressed air to dry parts, except bearings, after cleaning. Bearings must drip and air dry.

c. Tools. Do not use wire brushes, abrasive wheels, or compounds to clean parts unless specifically approved in the detailed procedures. Parts may be scratched or altered and may weaken a highly stressed part.

d. Ball and Roller Bearings. When cleaning ball or roller bearings, place them in a basket and suspend them in a container of Dry Cleaning Solvent P-D-680 (Item 65, Appendix D). If needed, use a brush to remove caked grease, chips, etc. Avoid rotating bearing before solid particles are removed to prevent damaging races and balls. When bearings have been cleaned, coat them lightly with lubricating oil (Item 42, Appendix D) to remove solvent.

2-43. GENERAL CLEANING INSTRUCTIONS (CONT)

CAUTION

Do not clean tires, lubricant seals, rubber hoses, or electrical components with solvent mixture. Failure to comply may result in damage to equipment.

e. Rubber Parts. Do not clean preformed packings or other rubber parts in Dry Cleaning Solvent. Wipe parts clean with a dry wiping rag (Item 50, Appendix D).

WARNING

Steam cleaning creates hazardous noise levels and severe burn potential. Eye, skin, and ear protection is required. Failure to comply may result in injury to personnel.

CAUTION

Steam cleaning may cause water to enter the transmission Electronic Control Unit (ECU) connector. Failure to dry off connector after steam cleaning may result in bad ECU codes.

f. Exterior Parts. Steam clean all exterior parts thoroughly before removing. This will make inspection and disassembly easier.

WARNING

Solvents used with a spray gun must be used in a spray booth with filter. Face shield must be used by personnel operating spray gun. Failure to comply may result in injury to personnel.

g. Engine, Cab, and Body. Use a spray gun and solvent mixture for cleaning exterior of engine, cab, and body. Allow mixture to remain on item surface for 10 minutes before rinsing. Rinse with hot water under 80 to 120 psi (550 to 830 kPa), if available. An ordinary garden hose with nozzle may be used if other equipment is not available. Rinse thoroughly.

CAUTION

To prevent corrosion, parts should be dipped in rust preventive within two hours of degreasing. Failure to comply may result in damage to equipment.

h. Degreasing Machine. A degreasing machine may be used to remove heavy grease and oil from metal parts.

WARNING

- **Dry Cleaning Solvent (P-D-680) is TOXIC and flammable. Wear protective goggles and gloves; use only in well ventilated area; avoid contact with skin, eyes, and clothes, and do not breathe vapors. Keep away from heat or flame. Never smoke when using solvent; the flashpoint for Type I Dry Cleaning Solvent is 100 degrees F (38 degrees C) and for Type II is 130 degrees F (50 degrees C). Failure to comply may result in serious injury or death to personnel.**
 - **If personnel become dizzy while using Dry Cleaning Solvent, immediately get fresh air and medical help. If solvent contacts skin or clothes, flush with cold water. If solvent contacts eyes, immediately flush eyes with water and get immediate medical attention. Failure to comply may result in injury to personnel.**
 - **Never use fuel to clean parts. Fuel is highly flammable. Serious injury or death could result if fuel ignites during cleaning.**
- i. **Passages.** After degreasing, check all oil passages and cavities for dirt or blockage before coating with lubricating oil (Item 42, Appendix D). Run a thin, flexible wire through oil passages to make sure they are not clogged. Use a pressure spray gun and Dry Cleaning Solvent P-D-680 (Item 65, Appendix D) to clean dirty passages.
- j. **Electrical Parts.** Electrical parts; such as coils, junction blocks, and switches; should not be soaked or sprayed with cleaning solutions. Clean these parts with a clean wiping rag (Item 50, Appendix D) moistened with Dry Cleaning Solvent P-D-680 (Item 65, Appendix D).

CAUTION

Do not use soap or alkalis for cleaning tank interiors. Failure to comply may result in damage to equipment.

- k. **Fuel Tank.** Pay special attention to all warnings and cautions when working on vehicle fuel tank. Fuel tanks should be flushed, using a spray gun and Dry Cleaning Solvent P-D-680 (Item 65, Appendix D).

WARNING

Battery acid (electrolyte) is extremely harmful. Always wear safety goggles and rubber gloves and do not smoke when performing maintenance on batteries. Injury will result if acid contacts skin or eyes. Wear rubber apron to prevent clothing being damaged.

- l. **Battery.** Exterior surfaces of the electrical system and battery should be cleaned with a weak solution of baking soda and water. Apply solution with a bristle brush to remove any corrosion. Pay special attention to all warnings and cautions when working on batteries.
- m. **Hydraulic System.** When cleaning hydraulic system parts use Dry Cleaning Solvent P-D-680 (Item 65, Appendix D). Clean and dry parts thoroughly to make sure no residue remains. If a coating of preservative is required before assembly, apply a light film of lubricating oil (Item 42, Appendix D).

2-44. GENERAL INSPECTION INSTRUCTIONS

- a. **Cleaning.** Clean all parts before inspection. Check for defects such as physical distortion, wear, cracks, and pitting.
- b. **Sealing Surfaces.** Inspect all surfaces in contact with gaskets, packings, or seals for nicks and burrs. If any defect is found, remove it before assembly.
- c. **Bearings.** Inspect bearings for rusted or pitted balls, races, or separators. Inspect balls and races for brinelling, abrasion, and serious discoloration. The following are conditions for bearing rejection:
 - (1) Cuts or grooves parallel to ball or roller rotation.
 - (2) Fatigue pits (not minor machine marks or scratches).
 - (3) Cracks.
- d. **Gears and Splined Shafts.** Inspect gears and splined shafts for wear, pittings, rolling, peening, scoring, burning, brinnelling and fatigue cracks.
- e. **Tubing and Hoses.** Inspect all hose surfaces for broken or frayed fabric. Check for breaks caused by sharp kinks or contact with other parts of the vehicle. Inspect copper tubing lines for kinks. Inspect fitting threads and mating surfaces for damage. Replace any defective part. After assembly and during initial vehicle operation period, check for leaks.
- f. **Electrical Parts.** Inspect all wiring harnesses and cable assemblies for broken, chafed, or burned wiring. Inspect all terminal connectors for loose connections and broken parts.
- g. **Metal Parts.** Visually inspect all castings and weldments for cracks. Parts that carry a great load should receive magnetic particle inspection. Critical non-ferrous parts may be inspected with fluorescent penetrant.
- h. **Drain Plugs.** When removing drain plugs from transmission, engine, hydraulic system components, or axle differential and planetary hubs, check amount of sediment on plugs. Accumulations of grit or fine metal particles may indicate actual or potential component failure. A few fine particles are normal. This inspection helps to determine if there are defective parts prior to internal inspection of the component and to predict degradation of the equipment.

2-45. GENERAL REPAIR INSTRUCTIONS

- a. **Burrs.** Remove burrs from surface teeth with a fine-cut file or crocus cloth.
- b. **Exterior Parts.** Chassis and exterior painted parts may be resurfaced when paint is damaged, or where parts have been repaired (TB 43-0242).

NOTE

Polished and machined steel parts not protected by cadmium, tin, copper, or other plating or surface treatment require protection. Bare metal parts must be free of moisture when protective coating is applied.

- c. **Protecting Parts.** Protect bare steel surfaces from rust when not actually undergoing repair work. Dip parts in, or spray them with, corrosion preventive compound (Item 18, Appendix D). Aluminum parts may require protection in atmospheres having a high salt content.

- d. Screws, Nuts and Fittings.** Replace any screw, nut, or fitting with damaged threads. Inspect tapped holes for thread damage. If cross-threading is evident retap the hole for the next oversize screw or stud. If the retapping will weaken the part, or if the cost of the part makes retapping impractical, replace the part. Chasing the threads with proper size tap or die may be adequate.
- e. Stud Installation.** When installing studs use a proper driver. A worn stud driver may damage the end thread. Then a chasing die must be used before a nut can be screwed on. This procedure will remove cadmium plating and allow corrosion. Before installing a stud, inspect the hole for chips. Blow out foreign matter and start stud by hand. Before final insertion, coat threads with a film of antiseize compound (Item 13, Appendix D). Install stud to proper "setting height", which is the total projecting length.
- f. Dents.** Straighten minor body dents by tapping with a soft-faced hammer while using a wooden block backing.
- g. Sheet Metal Repair.** Repair minor skin cracks by installing patches.
- h. Wire Repair.** Replace all broken, worn, or burned electrical wiring. Wires with several broken strands must be replaced. Broken strands will increase the resistance of the wire and impair efficiency of electrical components, especially the ignition system. Wire numbers must be permanently identified on any new wiring.
- i. Repair of Wires with Female Sockets.** Strip insulation from wire to equal depth of terminal well. Slide shell and sleeve over wire insulation. Insert wire into terminal well. Crimp terminal well on wire. Slide sleeve and shell over terminal.
- j. Repair of Wires with Male Plugs.** Strip insulation from wire to equal depth of terminal well. Slide shell over wire insulation. Insert wire into terminal well. Crimp terminal well on wire. Place slotted washer over crimped terminal well. Slide shell over slotted washer and terminal.
- k. Repair of Wires with Terminals of Various Configurations.** Strip insulation from wire to equal depth of terminal well. Slide insulator over insulation. Insert wire into terminal well. Crimp terminal well on wire. Slide insulator over crimped terminal well.
- l. Repair of Cables with Multiple Conductor Receptacle Connectors.** Remove insulation sleeving from cable. Discard insulation sleeving. Extract electrical contact from receptacle body. Strip insulation from wire to equal depth of well in electrical contact. Position insulation sleeving on cable. Crimp electrical contact on wire. Install electrical contact in receptacle body. Heat shrink insulation sleeving.
- m. Repair of Cables with Multiple Conductor Plug Connectors.** Remove insulation sleeving from cable. Discard insulation sleeving. Extract electrical contact from plug body. Strip insulation from wire to equal depth of well in electrical contact. Position insulation sleeving on cable. Crimp electrical contact on wire. Install electrical contact in plug body. Heat shrink insulation sleeving.
- n. Repair of Cables with Multiple Conductor Mate-N-Lock Series Connectors.** Remove electrical contact from connector body. Strip insulation equal to depth of well on electrical contact. Position wire end in electrical contact. Crimp electrical contact on wire end. Install electrical contact in connector body. Remove electrical contact from connector body. Strip insulation equal to depth of well on electrical contact. Position wire end in electrical contact. Crimp electrical contact on wire end. Install electrical contact in connector body.
- o. Repair of Cables with Multi-Conductor Metri-Pack Series Connectors.** Extract electrical contact from connector body. Strip insulation from wire to equal depth of well in electrical contact. Crimp electrical contact on wire. Install electrical contact in connector body.
- p. Repair of Cables with Multi-Conductor Sure-Seal Series Plug and Receptacle Connectors.** Remove insulation sleeving from connector body. Discard insulation sleeving. Extract electrical contact from connector body. Strip insulation from wire to equal depth of well in electrical contact. Position insulation sleeving on cable. Crimp electrical contact in connector body. Heat shrink insulation sleeving.

q. Repair of Cables with MIL-SPEC Solder-Type Terminal Connectors. Loosen two retaining screws on cable clamp. Remove cable clamp from connector body. Desolder wire from electrical contact. Remove wire from electrical contact. Strip insulation from wire to equal depth of well in electrical contact. Position wire in electrical contact. Solder wire to electrical contact. Install cable clamp on connector body with two retaining screws.

2-46. GENERAL ASSEMBLY INSTRUCTIONS

- a. Preparation.** Remove protective grease coatings from new parts before installation.
- b. Preformed Packing Installation.** Lubricate all preformed packings with a thin coat of lubricating oil (Item 42, Appendix D) before installing. To install a preformed packing, first clean the groove, then stretch packing and place into position. Place component on flat surface and uniformly press packing into position.
- c. Pipe Joints and Fittings.** Use antiseize compound (Item 13, Appendix D) or antiseizing tape (Item 66, Appendix D) to join pipes and fittings.
- d. Oil Seals.** Coat oil seals evenly with oil or grease before installing. Install oil seals with seal lip facing toward lubricant, applying an even force to outer edge of seal. If oil seals are to be installed over keyed or splined shafts, use a guide to prevent sharp edge of keyway or splines from cutting the leather or neoprene seal. Construct guides of very thin gauge sheet metal and shape to the required diameter. Make certain guide edges are not sharp and are bent slightly inward so they do not cut the seal.
- e. Bearings and Shafts.** When mounting bearings on shafts always apply force to the inner races. When mounting bearings into housing always apply the force to the outer race.
- f. Bearing Lubrication.** Lubricate bearings before assembly with lubricant used in the related housing or container to provide the first run-in until lubricant from the system can reach the bearings.

WARNING

On direct contact, uncured silicone sealant irritates eyes. In case of contact, flush eyes with water and seek medical attention. In case of skin contact, wipe off and flush with water. Failure to comply may result in injury to personnel.

g. Silicone Sealant. Silicone sealant is often used instead of a gasket to seal mating parts. The mating parts must be clean, dry, and free of oil or grease for proper adhesion. After silicone sealant has been applied, the mating parts must be assembled immediately. Silicone sealant starts to set-up in 15 minutes and takes 24 hours to completely dry. Excess silicone sealant should be wiped off after assembling the mating parts.

2-46. GENERAL ASSEMBLY INSTRUCTIONS (CONT)

h. Gaskets. Remove all traces of previous gasket and sealant before installing new gasket. Coat both sides of gasket with sealant to provide added sealing.

2-47. GENERAL INSTALLATION INSTRUCTIONS

a. Preparation. When unpacking items, remove all packing material, barrier paper, tape, plastic bags, protective caps and protective grease coatings. Handle and store removed components carefully.

CAUTION

Use sealing compound sparingly and only on threads. Do not apply compound to hose connections. Failure to comply may result in damage to equipment.

b. Sealing Compounds. Use only the sealing compounds specified in each maintenance task.

c. Torquing. Tighten bolts, screws, nuts, and fittings as required in each maintenance task or in Appendix F.

d. Identification Tags. Put hoses, tubes, lines, and electrical wiring in place by matching identification tags and markings on equipment.

e. Hoses, Air Lines and Wiring. After installing hoses, air lines and wiring, ensure that they do not contact moving parts or component edges. Secure in place, out of the way, with cable ties and cushion clamps.

f. Data Plate Installation.

Install data plate on vehicle with rivets.

g. Rivnut Installation.

Install rivnut on vehicle with rivets.

2-48. PREPARATION FOR STORAGE OR SHIPMENT INTRODUCTION

a. This section gives instructions for making the vehicle ready for shipment or storage.

b. Refer to AR 750-1 for detailed administrative storage instructions.

c. Refer to TB 9-2300-422-20 for security procedures.

2-49. PREPARATION FOR STORAGE OR SHIPMENT

a. Perform Preventive Maintenance Checks and Services (PMCS) listed in Table 2-1.

b. Correct all deficiencies noted during inspection, if facilities are available. If repairs are required, beyond the scope of Unit Maintenance, refer the deficiencies to Direct Support or General Support Maintenance.

2-50. STORAGE MAINTENANCE PROCEDURES

- a. Provide access to the vehicle during storage.

CAUTION

Ensure tires are not resting on surfaces containing grease or oil. Failure to comply may result in damage to equipment.

- b. Do not block wheels, but do be sure tires are not resting on surfaces containing grease or oil.
- c. Perform complete lubrication in accordance with TM 9-2320-366-10-1 and Appendix H.
- d. If possible, store vehicles close together, out of direct sunlight and away from electrical or generating equipment.
- e. Ensure the fuel tank contains at least 20 gallons (75.7 liters) of treated fuel. The fuel should be treated with Biobor J.F. The addition of 3 teaspoons of Biobor to 20 gallons of fuel will provide adequate protection against fungus growth. When storing a vehicle in freezing conditions, the addition of 3 ounces of isopropyl alcohol to every 20 gallons of diesel fuel will help prevent fuel-line freeze up.
- f. **Monthly Storage Maintenance Instructions.**
- (1) Conduct visual inspection of vehicle. Check lubricant, battery electrolyte, coolant level, and tire pressures. Correct any discrepancies.
 - (2) Inspect oil can points. Lubricate if necessary.
 - (3) Start engine and idle for 10 minutes. After 10 minutes of engine idle, operate engine for 5 minutes at 1500 rpm or until engine water temperature reaches 180 degrees F. Shift transmission slowly through all gear selector positions. Return transmission to neutral.
 - (4) Move vehicle 30 feet forward and reverse.
 - (5) Idle engine 10 minutes before shutdown.
 - (6) Check grease coating on all chromium plated and unpainted surfaces. If grease was wiped from chromium plates or unpainted surfaces when vehicle was moved, recoat these surfaces.
- g. **Quarterly Storage Maintenance Instructions.**
- (1) Move vehicle at least 1/4 mile. While driving, shift transmission through all gear ranges.
 - (2) Exercise all auxiliary equipment and winch. While operating winch or crane, lubricate hoist and cables.
- h. **Yearly Storage Maintenance Instructions.**
- (1) Clean exterior, engine, and undercarriage. Clean interior of cab. Wash any oil or grease from tires.
 - (2) Visually inspect vehicle. Check lubricant levels and tire pressures. Correct all discrepancies.
 - (3) Lubricate chassis, auxiliary equipment, winch, hoist cable, and oil can points.

CHAPTER 3 ENGINE MAINTENANCE

RESTRICTED MAINTENANCE NOTICE

Units not authorized SC 4910-95-CL-A72 (SHOP EQUIPMENT, COMMON NO. 2) in their T.O.E. may be unable to perform some of the maintenance tasks described in this chapter. If the required tools are not authorized, the equipment must be submitted to DS Maintenance for repair.

Section I. INTRODUCTION	3-1
3-1. INTRODUCTION	3-1
Section II. MAINTENANCE PROCEDURES	3-2
3-2. LIFTING PLATE REPLACEMENT	3-2
3-3. VALVE COVER AND GASKET REPLACEMENT	3-6
3-4. ENGINE OIL FILTER REPLACEMENT	3-10
3-5. CRANKCASE BREATHER REPLACEMENT	3-13
3-6. ENGINE AND TRANSMISSION OIL SAMPLING VALVES REPLACEMENT	3-15
3-7. ENGINE OIL FILL TUBE REPLACEMENT	3-19

Section I. INTRODUCTION

3-1. INTRODUCTION

This chapter contains maintenance instructions for replacing engine components authorized by the Maintenance Allocation Chart (MAC) at the Unit Maintenance level.

Section II. MAINTENANCE PROCEDURES

3-2. LIFTING PLATE REPLACEMENT

This task covers:

- a. Removal
- b. Installation
- c. Follow-On Maintenance

INITIAL SETUP

Equipment Conditions

- Engine shut down (TM 9-2320-366-10-1).
- Cab raised (TM 9-2320-366-10-1).

Tools and Special Tools

- Tool Kit, Genl Mech (Item 46, Appendix C)
- Goggles, Industrial (Item 15, Appendix C)
- Wrench, Torque, 0-175 lb-ft (Item 58, Appendix C)
- Container (40 qt (38 L) capacity)

WARNING

- Coolant may be very hot and under pressure from engine operation. Ensure engine is cool before performing maintenance. Failure to comply may result in injury to personnel.
- Wear appropriate eye protection when working under vehicle due to the possibility of falling debris. Failure to comply may result in injury to personnel.

a. Removal.

- (1) Remove radiator cap (1) from radiator overflow tank (2).
- (2) Position container under radiator draincock (3).
- (3) Open radiator draincock (3) and drain approximately five gallons (19 L) of coolant.
- (4) Close radiator draincock (3).

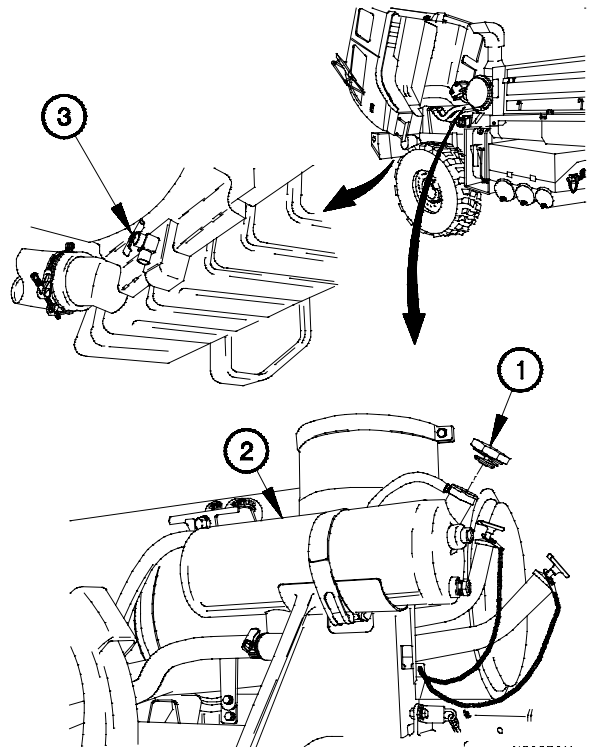

XC02R011

- (5) Disconnect air compressor inlet coolant tube (4) from fitting (5) on thermostat housing (6).

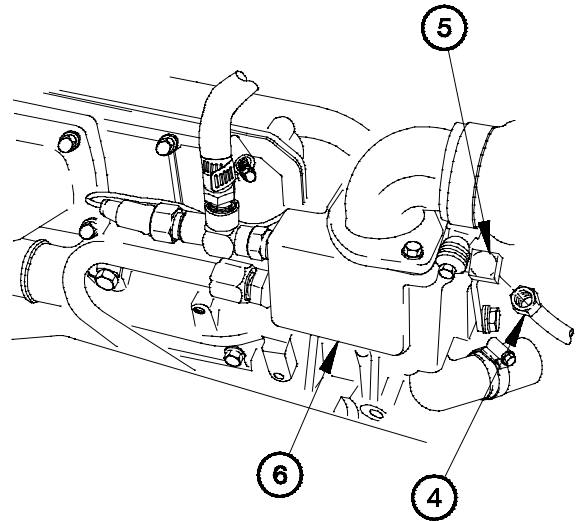

XC02R021

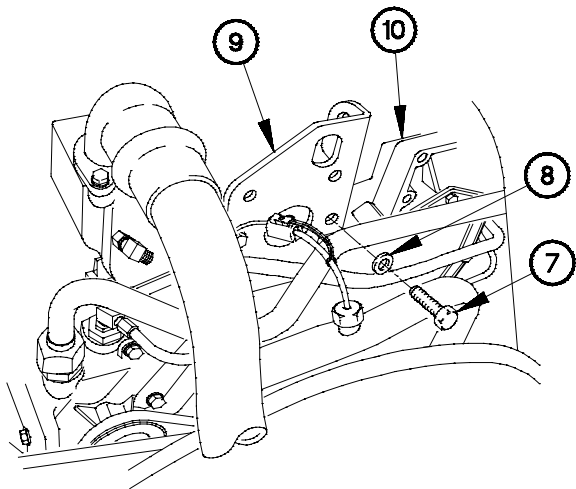

XC02R031

- (6) Remove five screws (7), washers (8), and front lifting plate (9) from engine (10).

- (7) Remove four screws (11), washers (12), and rear lifting plate (13) from engine (10).

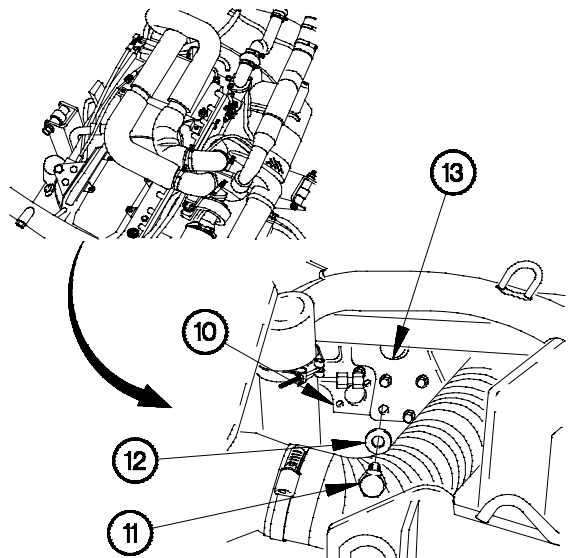

Xc02r041

3-2. LIFTING PLATE REPLACEMENT (CONT)

b. Installation.

- (1) Position rear lifting plate (1) on engine (2) with four washers (3) and screws (4).
- (2) Tighten four screws (4) to 47 lb-ft (64 N·m).

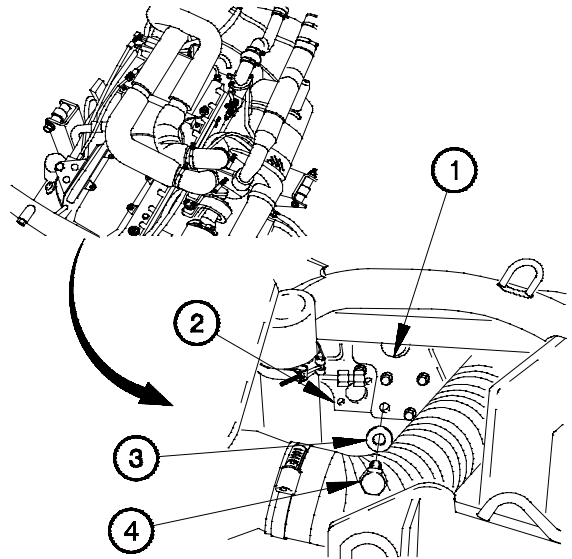

Xc021011

- (3) Position front lifting plate (5) on engine (2) with five washers (6) and screws (7).
- (4) Tighten five screws (7) to 47 lb-ft (64 N·m).

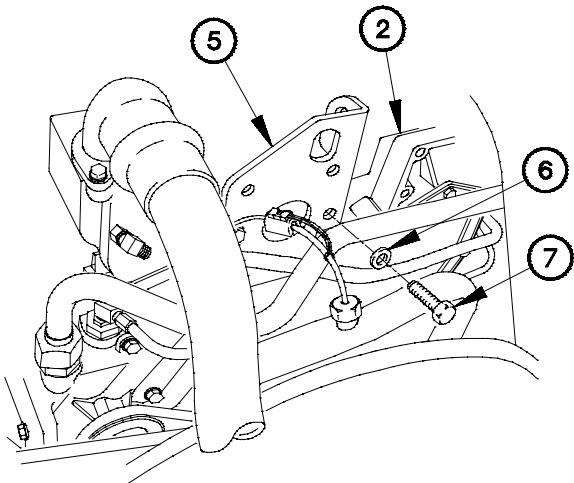

Xc021021

- (5) Connect air compressor inlet coolant tube (8) to fitting (9) on thermostat housing (10).

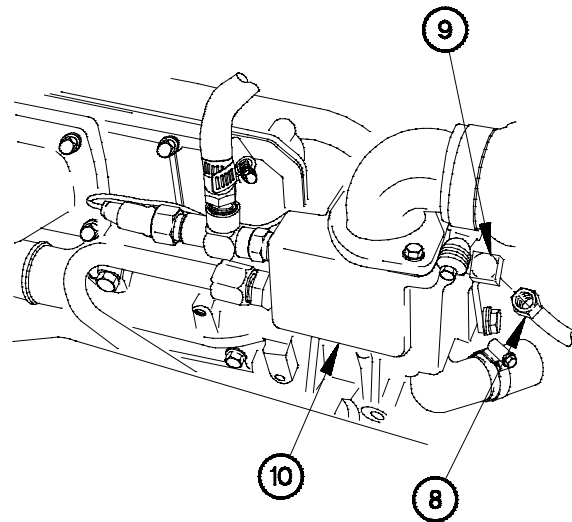

Xc021031

c. Follow-On Maintenance.

- (1) Lower cab (TM 9-2320-366-10-1).
- (2) Start engine (TM 9-2320-366-10-1).
- (3) Check for coolant leaks under vehicle.
- (4) Add coolant to radiator overflow tank (TM 9-2320-366-10-2).
- (5) Check coolant level after normal operating temperature is reached.
- (6) Check for coolant leaks under vehicle.
- (7) Raise cab (TM 9-2320-366-10-1).
- (8) Check around thermostat housing for coolant leaks.
- (9) Lower cab (TM 9-2320-366-10-1).
- (10) Shut down engine (TM 9-2320-366-10-1).

End of Task.

3-3. VALVE COVER AND GASKET REPLACEMENT

This task covers:

- a. Removal
- b. Installation
- c. Follow-On Maintenance

INITIAL SETUP

Equipment Conditions

Charge air cooler to air inlet elbow tubes/hoses removed (para 4-5).

Tool and Special Tools

Tool Kit, Genl Mech (Item 46, Appendix C)
 Wrench, Torque, 0-200 lb-in. (Item 59, Appendix C)
 Socket Set, Socket Wrench (Item 36, Appendix C)

Materials/Parts

Rag, Wiping (Item 50, Appendix D)
 Sealing Compound (Item 59, Appendix D)
 Gasket (for valve cover 7W5627) (Item 42, Appendix G)
 Gasket (for valve cover 119-2960) (Item 28, Appendix G)
 Adhesive (Item 6, Appendix D)
 Screw, Cap (14) (for replacement of valve cover 7W5627 with valve cover 119-2960) (Item 262, Appendix G)

a. Removal.

NOTE

Position hoses to allow access to valve cover.

- (1) Remove screw (1), washer (2), and clamp (3) from valve cover (4).

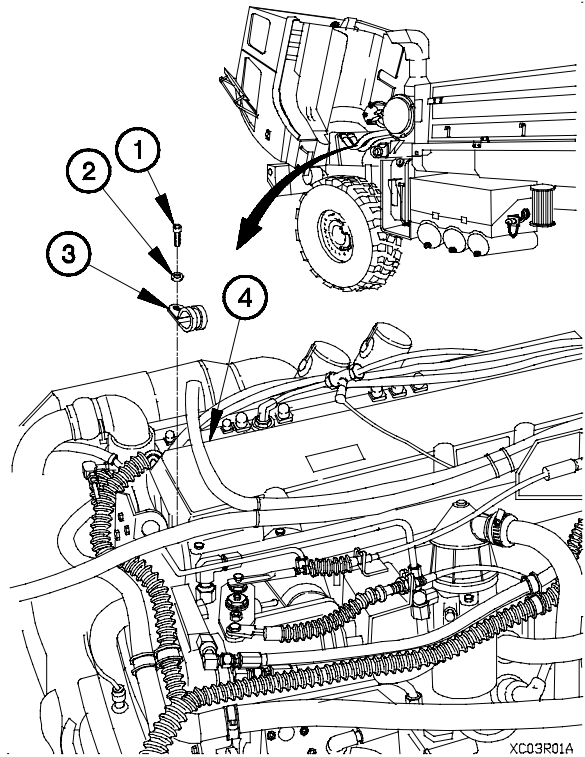

XC03R01A

CAUTION

Area around valve cover must be clean before removing valve cover from inlet manifold to prevent contaminants from entering inlet manifold. Failure to comply may result in damage to equipment.

- (2) Remove 13 screws (5) and washers (6) from valve cover (4).

CAUTION

Cover inlet manifold with wiping rags after valve cover is removed to prevent contamination of engine. Failure to comply may result in damage to equipment.

- (3) Remove valve cover (4) from inlet manifold (7).

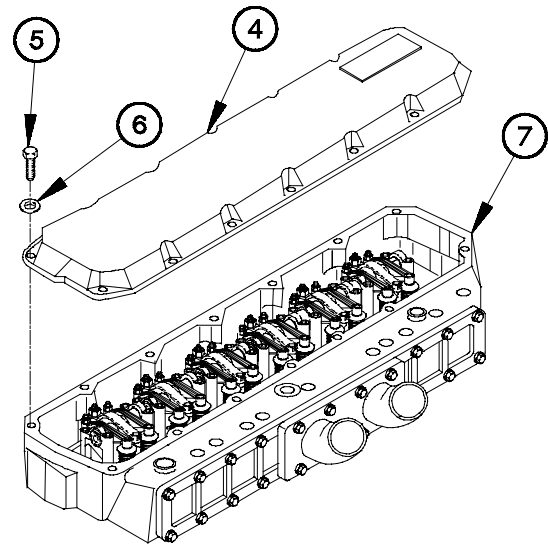

XC03R02-

- (4) Remove valve cover gasket (8) from valve cover (4). Discard gasket.

CAUTION

Engine data plate must remain with original engine. It contains engine serial number and other data for this engine. Failure to comply may result in damage to equipment.

- (5) Remove engine data plate (9) from valve cover (4).

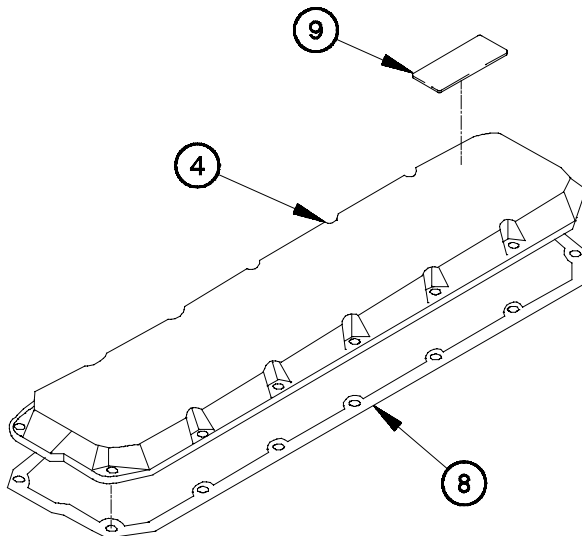

XC03R03-

3-3. VALVE COVER AND GASKET REPLACEMENT (CONT)

b. Installation.

WARNING

Adhesives, solvents, and sealing compounds can burn easily, can give off harmful vapors, and are harmful to skin and clothing. Keep away from open fire and use in a well-ventilated area. If adhesive, solvent, or sealing compound gets on skin or clothing, wash immediately with soap and water. Failure to comply may result in injury to personnel.

- (1) Install engine data plate (1) on valve cover (2) with adhesive.
- (2) Apply sealing compound between screw holes of valve cover (2).
- (3) Position valve cover gasket (3) on valve cover (2).

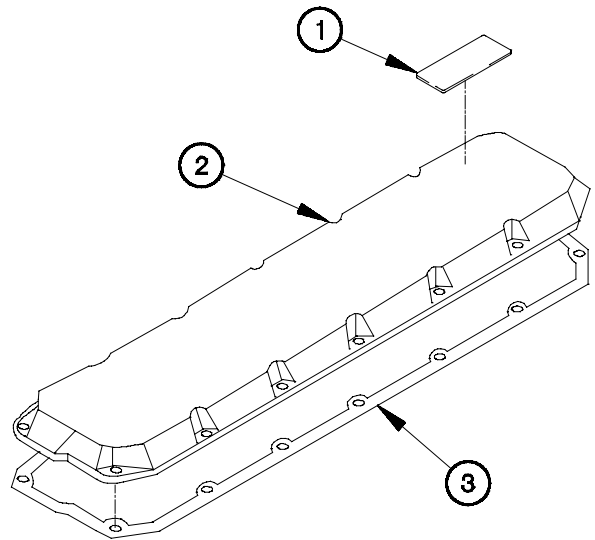

XC03101-

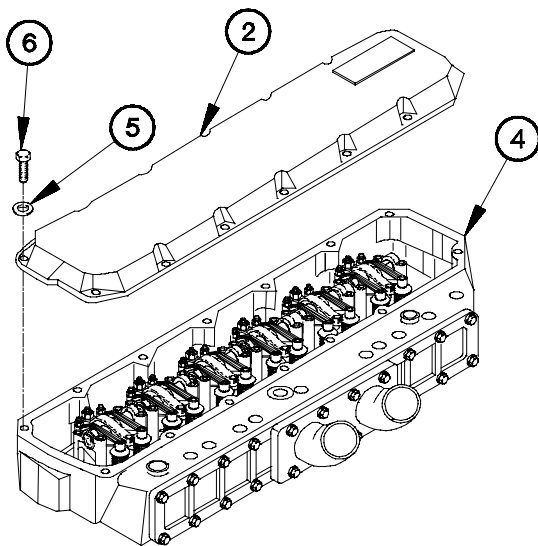

XC03102-

NOTE

Vehicle serial numbers 0001 through 3091 were originally equipped with valve cover part number 7W5627. Vehicle serial numbers 3092 and higher serial numbers were originally equipped with valve cover part number 119-2960. If replacing valve cover part number 7W5627 with valve cover part number 119-2960, it will be necessary to use the longer screws.

- (4) Position valve cover (2) on inlet manifold (4) with 13 washers (5) and screws (6).

- (5) Position clamp (7) on valve cover (2) with washer (8) and screw (9).

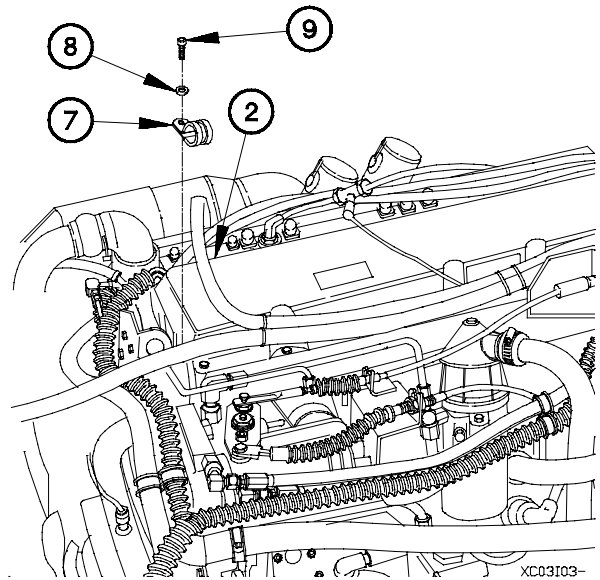

XC03I03-

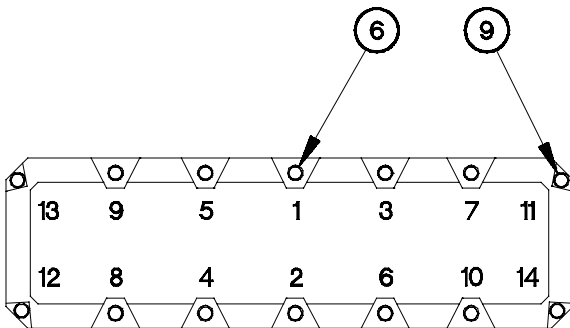

TIGHTENING SEQUENCE

XC03I04-

- (6) Tighten 13 screws (6) and screw (9) to 84-132 lb-in. (9-15 N·m) in sequence shown.

c. Follow-On Maintenance.

- (1) Install charge air cooler to air inlet elbow tubes/hoses (para 4-5).
- (2) Lower cab (TM 9-2320-366-10-1).
- (3) Start engine (TM 9-2320-366-10-1).
- (4) Raise cab (TM 9-2320-366-10-1).
- (5) Check for oil leaks around valve cover gasket.
- (6) Lower cab (TM 9-2320-366-10-1).
- (7) Shut down engine (TM 9-2320-366-10-1).

End of Task.

3-4. ENGINE OIL FILTER REPLACEMENT

This task covers:

- a. Removal
- b. Installation
- c. Follow-On Maintenance

INITIAL SETUP

Equipment Conditions

- Engine shut down (TM 9-2320-366-10-1).
- Cab raised (TM 9-2320-366-10-1).

Tools and Special Tools

- Tool Kit, Genl Mech (Item 46, Appendix C)
- Goggles, Industrial (Item 15, Appendix C)
- Wrench, Strap, Adjustable (Item 57, Appendix C)
- Container (40 qt (38 L) capacity)

Materials/Parts

- Oil, Lubricating, OE/HDO 30 (Item 45, Appendix D)
- Filter, Oil (Item 23, Appendix G)
- Packing, Preformed (Item 203, Appendix G)

WARNING

- Wear appropriate eye protection when working under vehicle due to the possibility of falling debris. Failure to comply may result in injury to personnel.
- Do not remove oil filter while engine is hot. Failure to comply may result in injury to personnel.

a. Removal.

- (1) Position container under oil pan (1).
- (2) Remove oil pan plug (2) from oil pan (1).
- (3) Remove preformed packing (3) from oil pan drain plug (2). Discard preformed packing.

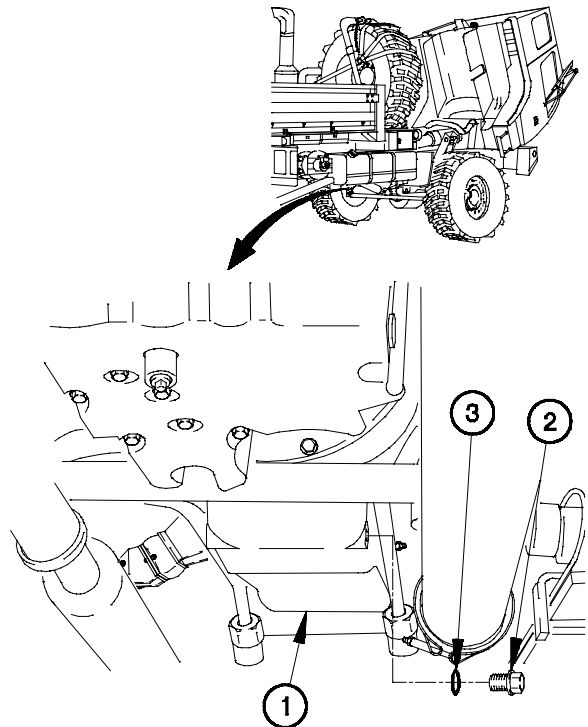

XC04R01A

(4) Remove oil filter (4) from oil filter base (5). Discard oil filter.

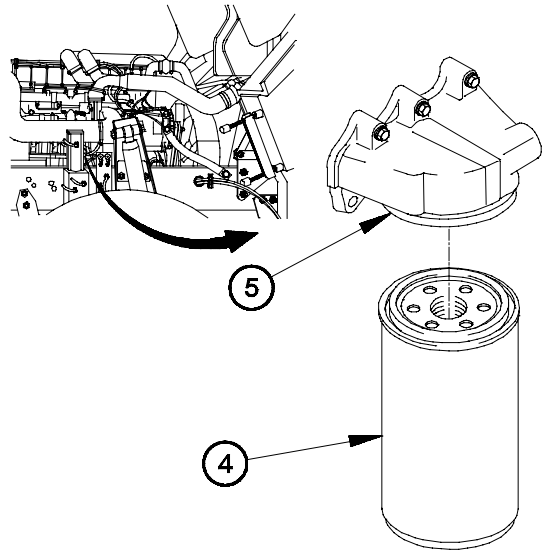

XC04R02A

b. Installation.

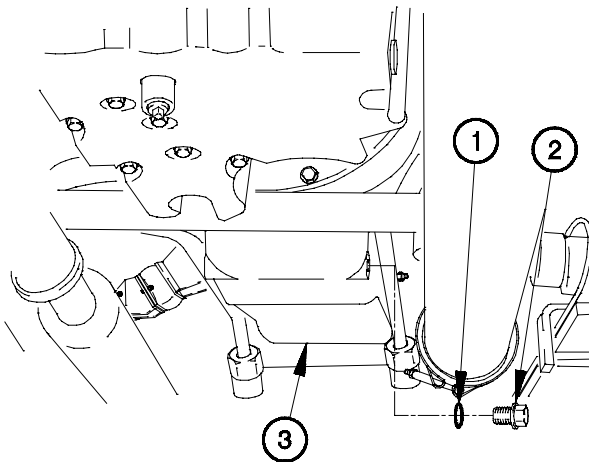

XC04I01A

- (1) Install preformed packing (1) on oil pan drain plug (2).
- (2) Install oil pan drain plug (2) in oil pan (3).

(3) Apply a thin coat of lubricating oil to oil filter gasket (4).

(4) Install oil filter (5) on oil filter base (6), hand tight.

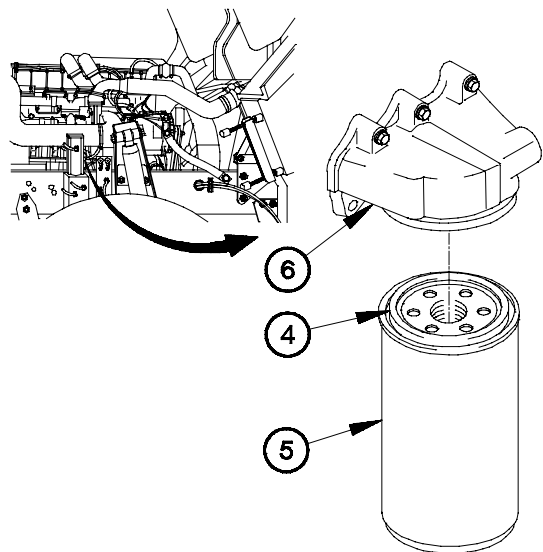

XC04I02A

3-4. ENGINE OIL FILTER REPLACEMENT (CONT)

c. Follow-On Maintenance.

- (1) Add oil to engine (Appendix H).
- (2) Lower cab (TM 9-2320-366-10-1).
- (3) Check for oil leaks under vehicle.
- (4) Start engine (TM 9-2320-366-10-1).
- (5) Raise cab (TM 9-2320-366-10-1).
- (6) Check for oil leaks around oil filter and oil pan drain plug.
- (7) Check engine oil level (TM 9-2320-366-10-2); if low, add oil (Appendix H).
- (8) Lower cab (TM 9-2320-366-10-1).
- (9) Shut down engine (TM 9-2320-366-10-1).

End of Task.

3-5. CRANKCASE BREATHER REPLACEMENT

This task covers:

- a. Removal
- b. Installation
- c. Follow-On Maintenance

INITIAL SETUP

Equipment Conditions

Engine shut down (TM 9-2320-366-10-1).
 Cab raised (TM 9-2320-366-10-1).

Tools and Special Tools

Tool Kit, Genl Mech (Item 46, Appendix C)
 Wrench, Torque, 0-200 lb-in. (Item 59, Appendix C)
 Socket Set, Socket Wrench (Item 35, Appendix C)

Materials/Parts

Rag, Wiping (Item 50, Appendix D)
 Packing, Preformed (Item 207, Appendix G)
 Oil, Lubricating, OE/HDO 30 (Item 45, Appendix D)

a. Removal.

CAUTION

Wipe around fuel filter base before removing crankcase breather housing. Failure to comply may result in damage to equipment.

- (1) Loosen hose clamp (1) on hose (2).
- (2) Remove hose (2) from crankcase breather housing (3).
- (3) Remove screw (4) and washer (5) from crankcase breather housing (3).

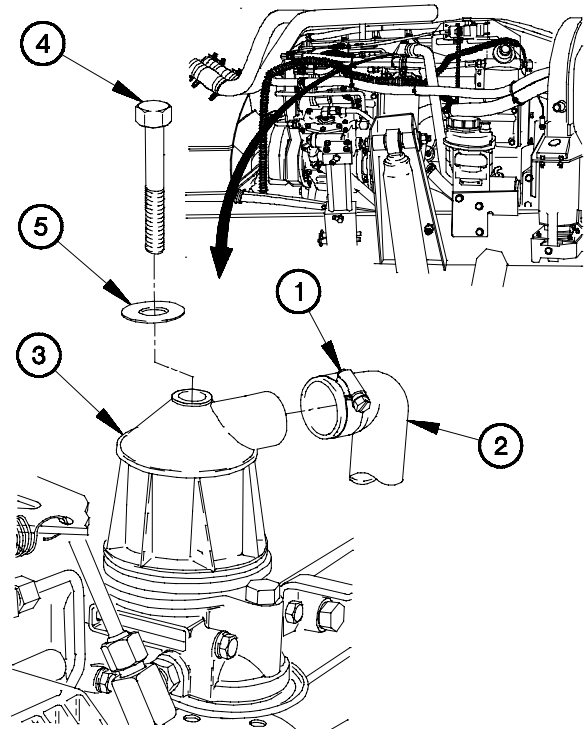

XC05R01A

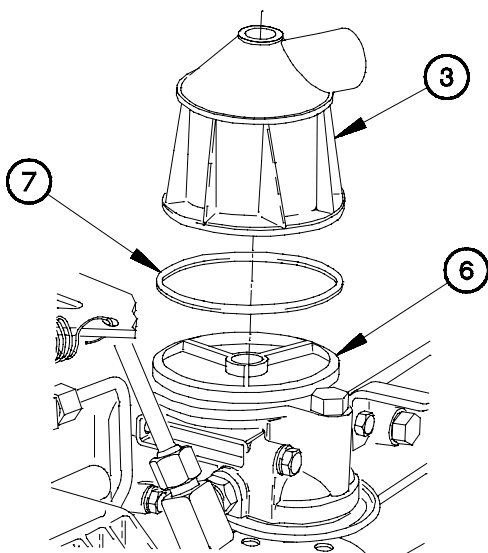

XC05R02-

- (4) Remove crankcase breather housing (3) from fuel filter base (6).
- (5) Remove preformed packing (7) from fuel filter base (6). Discard preformed packing.

3-5. CRANKCASE BREATHER REPLACEMENT (CONT)

b. Installation.

- (1) Apply a thin coat of lubricating oil to both sides of preformed packing (1).
- (2) Install preformed packing (1) on fuel filter base (2).
- (3) Position crankcase breather housing (3) on fuel filter base (2) with washer (4) and screw (5).
- (4) Tighten screw (5) to 96-144 lb-in. (11-16 N·m).
- (5) Position hose (6) on crankcase breather housing (3) with clamp (7).
- (6) Tighten clamp (7) to 35-45 lb-in. (4-5 N·m).

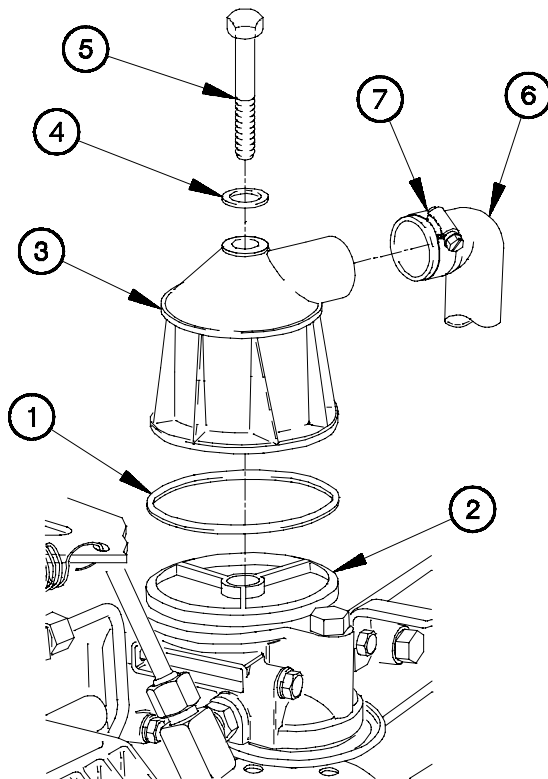

XC05101A

c. Follow-On Maintenance.

- (1) Lower cab (TM 9-2320-366-10-1).
- (2) Start engine (TM 9-2320-366-10-1).
- (3) Check for oil leaks under vehicle.
- (4) Raise cab (TM 9-2320-366-10-1).
- (5) Check for oil leaks around breather housing gasket.
- (6) Lower cab (TM 9-2320-366-10-1).
- (7) Shut down engine (TM 9-2320-366-10-1).

End of Task.

3-6. ENGINE AND TRANSMISSION OIL SAMPLING VALVES REPLACEMENT

This task covers:

- a. Removal
- b. Installation
- c. Follow-On Maintenance

INITIAL SETUP

Equipment Conditions

- Engine shut down (TM 9-2320-366-10-1).
- Cab raised (TM 9-2320-366-10-1).

Tools and Special Tools

- Goggles, Industrial (Item 15, Appendix C)
- Pan, Drain (Item 24, Appendix C)
- Tool Kit, Genl Mech (Item 46, Appendix C)
- Wrench, Torque, 0-200 lb-in. (Item 59, Appendix C)
- Wrench Set, Socket (Item 51, Appendix C)

Materials/Parts

- Dispenser, Pressure Sensitive Adhesive Tape (Item 20, Appendix D)
- Packing, Preformed (Item 186, Appendix G)
- Antiseize Compound (Item 58, Appendix D)

WARNING

Wear appropriate eye protection when working under vehicle due to the possibility of falling debris. Failure to comply may result in injury to personnel.

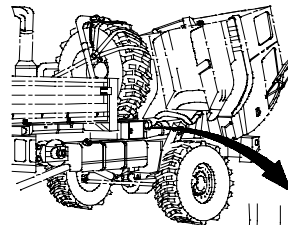

a. Removal.

- (1) Position drain pan under transmission oil sampling valve (1) and engine oil sampling valve (2).

NOTE

Tag hoses and connection points prior to disconnecting.

- (2) Disconnect transmission oil sampling hose (3) from transmission oil sampling valve (1).
- (3) Disconnect engine oil sampling hose (4) from engine oil sampling valve (2).
- (4) Remove nut (5) and transmission oil sampling valve (1) from bracket (6).
- (5) Remove nut (7) and engine oil sampling valve (2) from bracket (6).

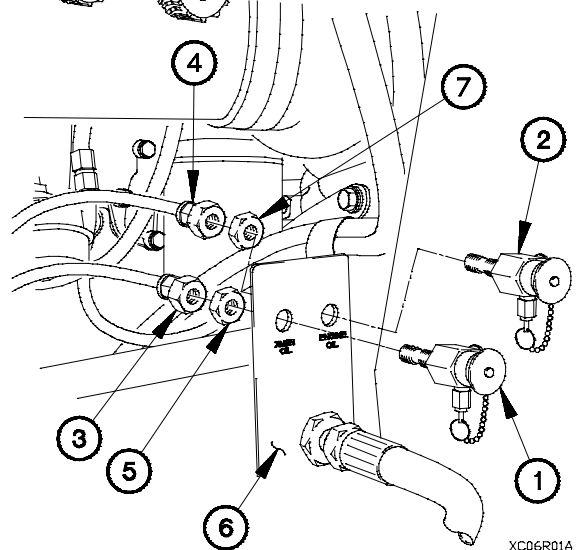

3-6. ENGINE AND TRANSMISSION SAMPLING VALVE REPLACEMENT (CONT)

(6) Remove transmission oil sampling hose (3) from 45-degree fitting (8).

NOTE

- Note orientation of fitting prior to removal.
- Perform steps (7) and (8) on vehicles equipped with transmission oil cooler tubes.

(7) Remove 45-degree fitting (8) from transmission oil cooler tube (9).

(8) Remove preformed packing (10) from 45-degree fitting (8). Discard preformed packing.

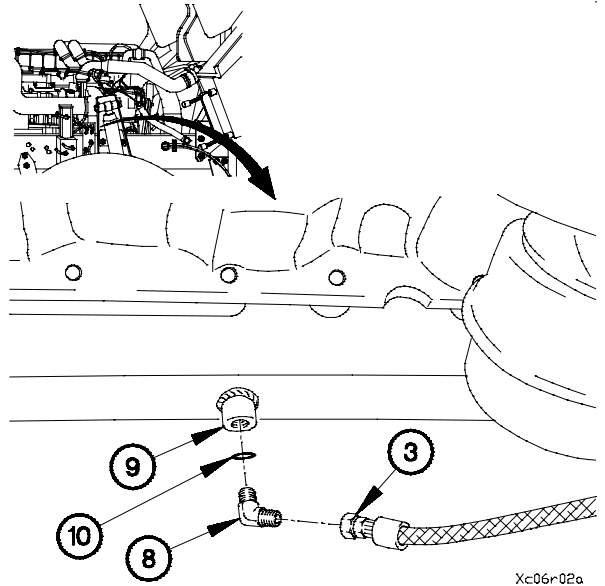

NOTE

Perform step (9) on vehicles equipped with transmission oil cooler hoses.

(9) Remove 45-degree fitting (8) from transmission oil cooler hose (9).

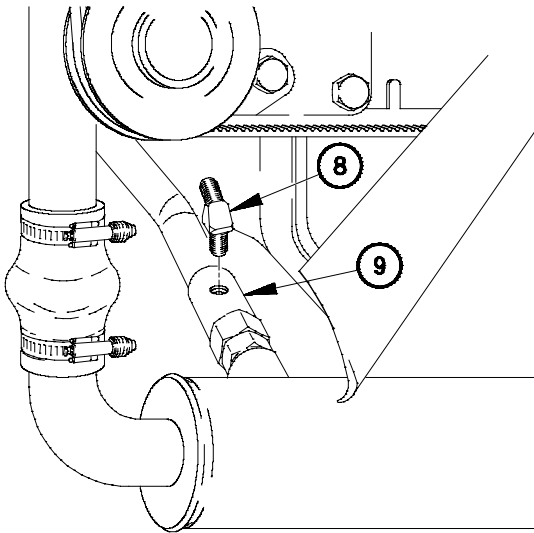

(10) Remove engine oil sampling hose (4) from adapter (11).

(11) Remove adapter (11) from 90-degree fitting (12).

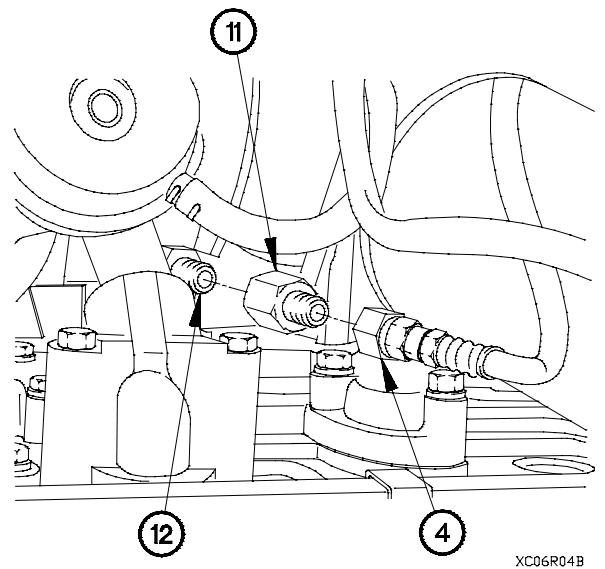

b. Installation.

WARNING

Adhesives, solvents, and sealing compounds can burn easily, can give off harmful vapors, and are harmful to skin and clothing. Keep away from open fire and use in a well-ventilated area. If adhesive, solvent, or sealing compound gets on skin or clothing, wash immediately with soap and water. Failure to comply may result in injury to personnel.

- (1) Apply antiseize compound to threads of adapter (1).
- (2) Install adapter (1) on 90-degree fitting (2).
- (3) Install engine oil sampling hose (3) on adapter (1).

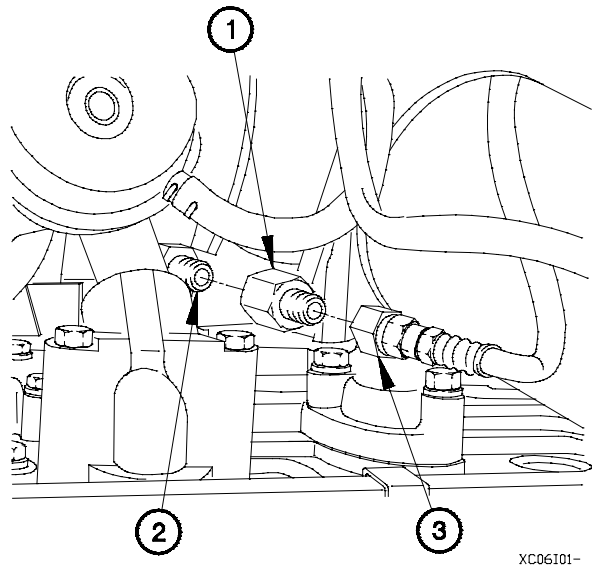

XC06101-

NOTE

Perform steps (4) and (5) on vehicles equipped with transmission oil cooler tubes.

- (4) Install preformed packing (4) on 45-degree fitting (5).
- (5) Install 45-degree fitting (5) in transmission oil cooler tube (6).

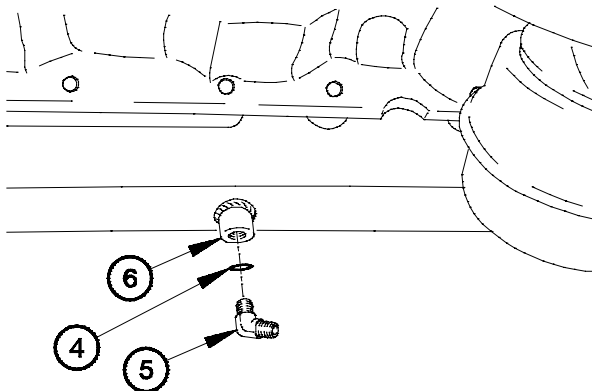

XC06102B

NOTE

Perform step (5.1) and (5.2) on vehicles equipped with transmission oil cooler hoses.

- (5.1) Apply antiseize compound to threads of 45-degree fitting (5).
- (5.2) Install 45-degree fitting (5) in transmission oil cooler hose (6).
- (6) Install transmission oil sampling hose (7) on 45-degree fitting (5).

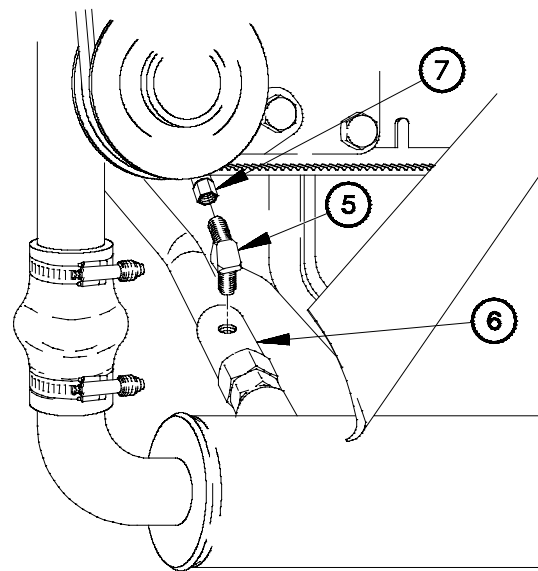

XC06103B

3-6. ENGINE AND TRANSMISSION SAMPLING VALVE REPLACEMENT (CONT)

- (7) Position engine oil sampling valve (8) on bracket (9) with nut (10).
- (8) Position transmission oil sampling valve (11) on bracket (9) with nut (12).
- (9) Tighten nuts (10 and 12) to 67 lb-in. (8 N·m).
- (10) Install engine oil sampling hose (3) on engine oil sampling valve (8).
- (11) Install transmission oil sampling hose (7) on transmission oil sampling valve (11).

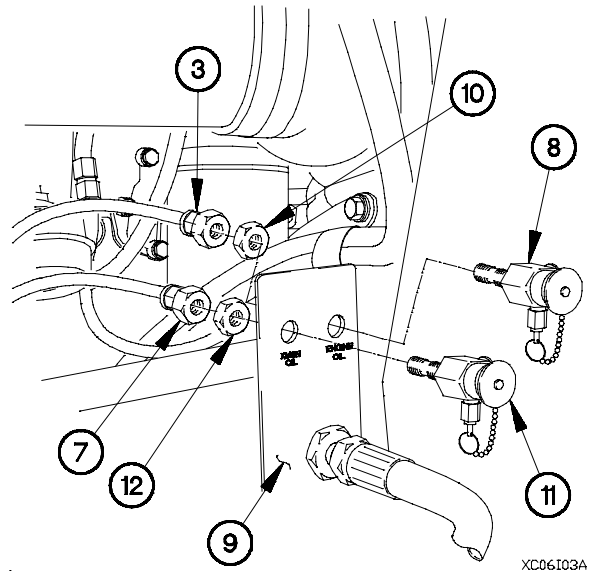

c. Follow-On Maintenance.

- (1) Lower cab (TM 9-2320-366-10-1).
- (2) Check for oil leaks under vehicle.
- (3) Start engine (TM 9-2320-366-10-1).
- (4) Raise cab (TM 9-2320-366-10-1).
- (5) Check for oil leaks around transmission and engine oil sampling hoses and valves.
- (6) Lower cab (TM 9-2320-366-10-1).
- (7) Shut down engine (TM 9-2320-366-10-1).

End of Task.

3-7. ENGINE OIL FILL TUBE REPLACEMENT

This task covers:

- a. Removal
- b. Installation
- c. Follow-On Maintenance

INITIAL SETUP

Equipment Conditions

- Engine shut down (TM 9-2320-366-10-1).
- Cab raised (TM 9-2320-366-10-1).
- Transmission oil fill tube removed (Para 8-22).

Tools and Special Tools

- Tool Kit, Genl Mech (Item 46, Appendix C)
- Wrench, Torque, 0-175 lb-ft (Item 58, Appendix C)
- Screwdriver Attachment, Socket Wrench (Item 61, Appendix B)

Tools and Special Tools (Cont)

- Wrench, Torque, 0-200 lb-in. (Item 59, Appendix C)
- Socket Set, Socket Wrench (Item 36, Appendix C)

Materials/Parts

- Nut, Self-Locking (2) (all models except M1093/M1094) (Item 167, Appendix G)
- Nut, Self-Locking (M1093/M1094) (Item 167, Appendix G)

a. Removal.

- (1) Remove cap (1) from engine oil fill tube (2).

NOTE

Perform steps (2) and (3) on all models except M1093/M1094.

- (2) Remove self-locking nut (3), washer (4), engine oil fill tube (2), screw (5), and washer (6) from radiator overflow tank bracket (7). Discard self-locking nut.

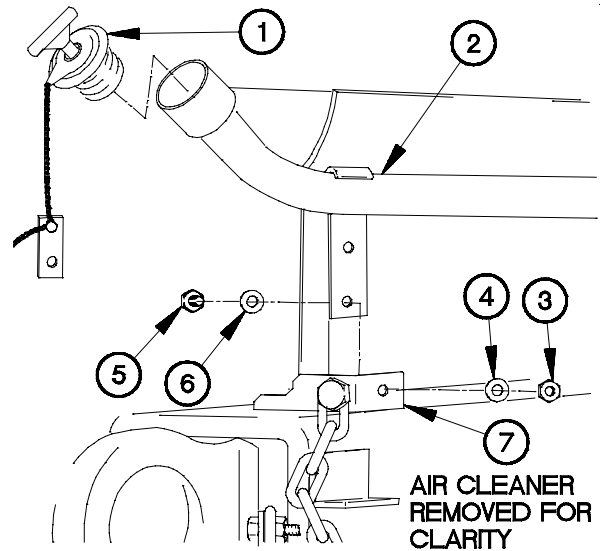

XC07R01A

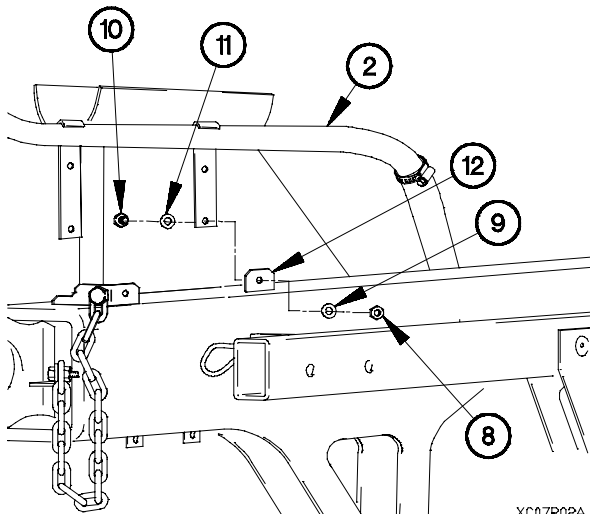

XC07R02A

- (3) Remove self-locking nut (8), washer (9), engine oil fill tube (2), screw (10), and washer (11) from front lifting beam (12). Discard self-locking nut.

3-7. ENGINE OIL FILL TUBE REPLACEMENT (CONT)

NOTE

Perform step (4) on M1093/M1094.

- (4) Remove self-locking nut (3), washer (4), engine oil fill tube (2), screw (13), washer (6), and spacer (14) from radiator overflow tank bracket (7). Discard self-locking nut.

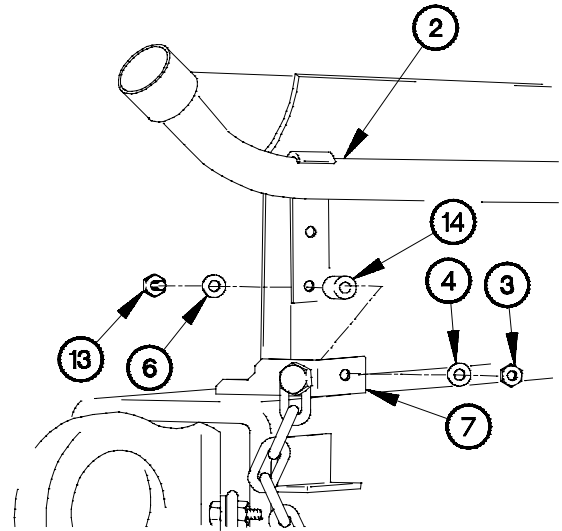

XC07R03A

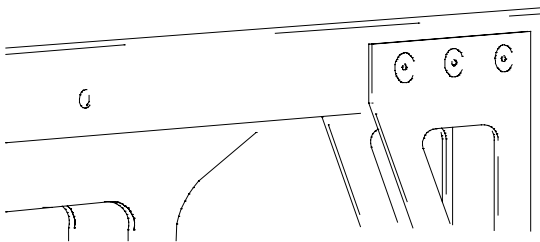
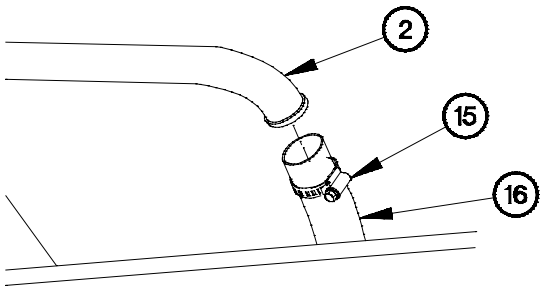

XC07R04A

- (5) Loosen clamp (15) on engine oil fill hose (16).
- (6) Remove engine oil fill tube (2) from engine oil fill hose (16).

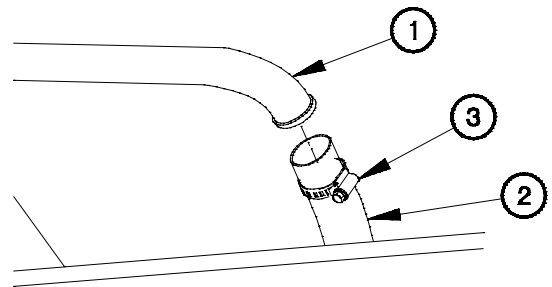

XC07I01A

b. Installation.

- (1) Position engine oil fill tube (1) in engine oil fill hose (2) with clamp (3).
- (2) Tighten clamp (3) to 24-48 lb-in. (3-5 N·m).

NOTE

Perform steps (3) and (4) on M1093/ M1094.

- (3) Position engine oil fill tube (1) on radiator overflow tank bracket (4) with spacer (5), washer (6), screw (7), washer (8), and self-locking nut (9).
- (4) Tighten self-locking nut (9) to 22-26 lb-ft (29-35 N-m).

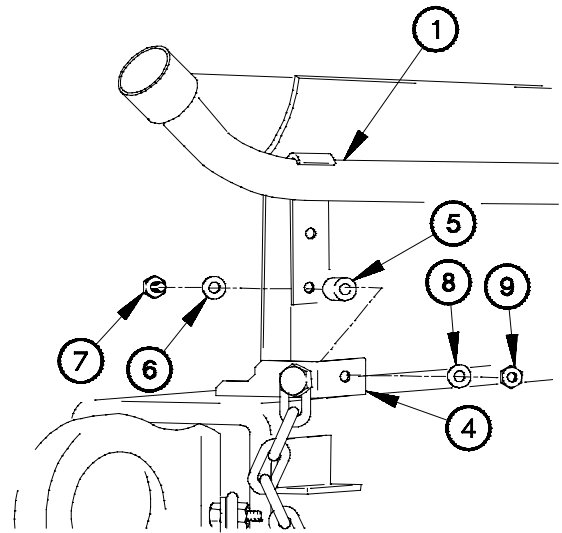

XC07102A

NOTE

Perform steps (5) through (7) on all models except M1093/M1094.

- (5) Position engine oil fill tube (1) on front lifting beam (10) with washer (11), screw (12), washer (13), and self-locking nut (14).

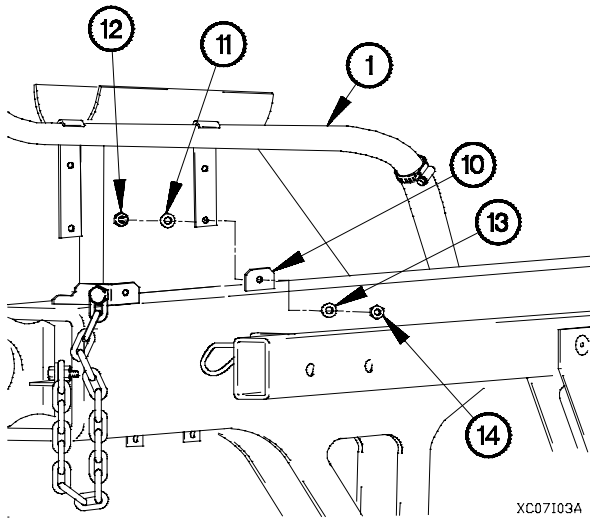

XC07103A

- (6) Position engine oil fill tube (1) on radiator overflow tank bracket (4) with washer (6), screw (15), washer (8), and self-locking nut (9).
- (7) Tighten self-locking nuts (9 and 14) to 22-26 lb-ft (29-35 N-m).
- (8) Install cap (16) on engine oil fill tube (1).

c. Follow-On Maintenance.

- (1) Install transmission oil fill tube (para 8-22).
- (2) Lower cab (TM 9-2320-366-10-1).

End of Task.

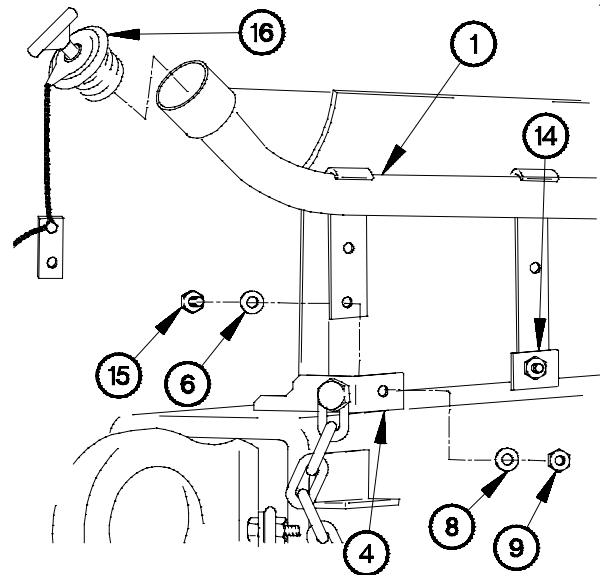

XC07104B

CHAPTER 4 FUEL SYSTEM MAINTENANCE

RESTRICTED MAINTENANCE NOTICE

Units not authorized SC 4910-95-CL-A72 (SHOP EQUIPMENT, COMMON NO. 2) in their T.O.E. may be unable to perform some of the maintenance tasks described in this chapter. If the required tools are not authorized, the equipment must be submitted to DS Maintenance for repair.

Section I. INTRODUCTION	4-1
4-1. INTRODUCTION	4-1
Section II. MAINTENANCE PROCEDURES	4-2
4-2. INTAKE AIR CLEANER FILTER ELEMENT, AIR CLEANER ASSEMBLY, AND PARTICLE EXTRACTION TUBE REPLACEMENT	4-2
4-3. FUEL PRESSURE REGULATING VALVE REPLACEMENT	4-25
4-4. TURBOCHARGER TO CHARGE AIR COOLER TUBE AND HOSES REPLACEMENT	4-28
4-5. CHARGE AIR COOLER TO AIR INLET ELBOW TUBES AND HOSES REPLACEMENT	4-31
4-6. FUEL RATIO CONTROL TUBE REPLACEMENT	4-38
4-7. ORIFICE TUBE ASSEMBLY REPLACEMENT	4-41
4-8. FUEL TANK AND BRACKETS REPLACEMENT	4-43
4-9. FUEL HOSES REPLACEMENT	4-51
4-10. FUEL FILTER TUBES REPLACEMENT	4-61
4-11. FUEL SYSTEM BLEEDING	4-68
4-12. GOVERNOR LINKAGE REPLACEMENT	4-70
4-13. FUEL/WATER SEPARATOR AND FILTER REPLACEMENT	4-73
4-14. FUEL FILTER AND FILTER BASE REPLACEMENT	4-77
4-15. ETHER STARTING AID REPLACEMENT	4-82
4-16. THROTTLE POSITION SENSOR (TPS) CABLE ASSEMBLY REPLACEMENT	4-85
4-17. HAND THROTTLE LEVER REPLACEMENT/ADJUSTMENT	4-88
4-18. THROTTLE CONTROL CABLE REPLACEMENT/ADJUSTMENT	4-90
4-19. THROTTLE CONTROL THREADED ROD REPLACEMENT	4-97
4-20. THROTTLE CONTROL LEVER REPLACEMENT	4-100
4-21. ACCELERATOR PEDAL REPLACEMENT	4-103
4-22. CHECKING AND STENCILING HIGH/LOW HAND THROTTLE POSITIONS	4-104

Section I. INTRODUCTION

4-1. INTRODUCTION

This chapter contains maintenance instructions for replacing, repairing, and adjusting fuel system components authorized by the Maintenance Allocation Chart (MAC) at the Unit Maintenance level.

Section II. MAINTENANCE PROCEDURES

4-2. INTAKE AIR CLEANER FILTER ELEMENT, AIR CLEANER ASSEMBLY, AND PARTICLE EXTRACTION TUBE REPLACEMENT	
This task covers:	
<ul style="list-style-type: none"> a. Intake Air Cleaner Filter Element Removal b. Intake Air Cleaner Filter Element Installation c. Intake Air Cleaner Assembly Removal (All Models Except M1093/M1094) d. M1093/M1094 Intake Air Cleaner Assembly Removal e. Intake Air Cleaner Disassembly f. Intake Air Cleaner Assembly 	<ul style="list-style-type: none"> g. M1093/M1094 Intake Air Cleaner Assembly Installation h. Intake Air Cleaner Assembly Installation (All Models Except M1093/M1094) i. Particle Extraction Tube Removal j. Particle Extraction Tube Installation k. Follow-On Maintenance
INITIAL SETUP	
<p>Equipment Conditions Engine shut down (TM 9-2320-366-10-1). Cab raised (TM 9-2320-366-10-1). Batteries disconnected (para 7-57). Chemical detection unit removed, if equipped (TM 3-6665-225-12). Transmission oil fill tube removed (M1093/M1094) (para 8-22).</p>	<p>Tools and Special Tools (Cont) Wrench, Torque, 0-200 lb-in. (Item 59, Appendix C)</p>
<p>Tools and Special Tools Tool Kit, Genl Mech (Item 46, Appendix C) Wrench, Torque, 0-175 lb-ft (Item 59, Appendix C) Crowfoot Attachment, Socket Wrench (Item 6, Appendix B) Screwdriver Attachment, Socket Wrench (Item 61, Appendix B) Socket Set, Socket Wrench (Item 36, Appendix C)</p>	<p>Materials/Parts Rag, Wiping (Item 50, Appendix D) Gasket (Item 31, Appendix G) Filter Element (Item 21, Appendix G) Washer, Spring (2) (Item 291, Appendix G) Nut, Self-Locking (3) (Item 156, Appendix G) Nut, Self-Locking (3) (M1093/M1094) (Item 150, Appendix G) Nut, Self-Locking (3) (all models except M1093/M1094) (Item 157, Appendix G)</p>
	<p>References TM 3-6665-225-12 FM 3-4 FM 3-5</p>



After Nuclear, Biological, or Chemical (NBC) exposure of vehicle, all air filters shall be handled with extreme caution. Unprotected personnel may experience serious injury or death if residual toxic agents or radioactive materials are present. If vehicle is exposed to chemical or biological agents, servicing personnel shall wear protective mask, hood, protective overgarments, and chemical protective gloves and boots in accordance with FM-3-4. All contaminated air filters shall be placed in double-lined plastic bags and moved swiftly to a segregation area away from the worksite. The same procedure applies for radioactive dust contamination. The Company NBC team should measure radiation prior to filter removal to determine extent of safety procedures required per the NBC Annex to the unit Standard Operating Procedures (SOP). The segregation area in which the contaminated air filters are temporarily stored shall be marked with appropriate NBC placards. Final disposal of contaminated air filters shall be in accordance with local SOP. Decontamination operation shall be in accordance with FM-3-5 and local SOP. Failure to comply may result in serious injury or death to personnel.

a. Intake Air Cleaner Filter Element Removal.

- (1) Unlatch three clasps (1) on cover (2).
- (2) Remove cover (2) from intake air cleaner housing (3).
- (3) Loosen wingnut (4) and remove filter element (5) from intake air cleaner housing (3). Discard filter element.

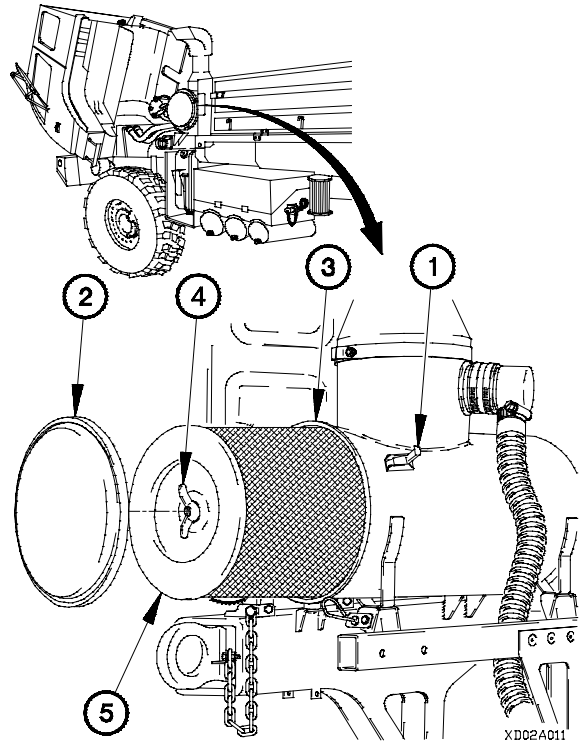

b. Intake Air Cleaner Filter Element Installation.

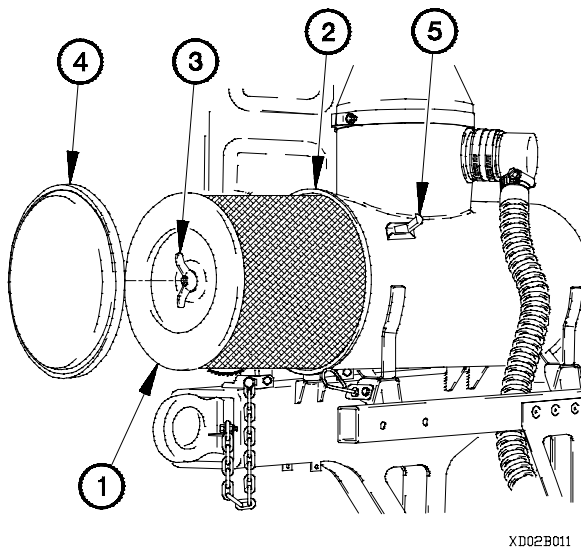

NOTE

Wipe inside of intake air cleaner housing with damp wiping rag.

- (1) Position filter element (1) in intake air cleaner housing (2).

CAUTION

Tighten wingnut securely to prevent air leakage around air cleaner filter element. Do not overtighten. Failure to comply may result in damage to equipment.

- (2) Tighten wingnut (3) on filter element (1).
- (3) Install cover (4) on intake air cleaner housing (2) with three clasps (5).

4-2. INTAKE AIR CLEANER FILTER ELEMENT, AIR CLEANER ASSEMBLY, AND PARTICLE EXTRACTION TUBE REPLACEMENT (CONT)

c. Intake Air Cleaner Assembly Removal (All Models Except M1093/M1094).

- (1) Remove dust cap (1) from connector J106 (2).
- (2) Remove nut (3), dust cap lanyard (4), and connector J106 (2) from chemical detector mounting bracket (5).
- (3) Remove four screws (6) and washers (7) from chemical detector mounting bracket (5).
- (4) Disconnect air filter restriction gauge hose (8) from air flow sensor (9).

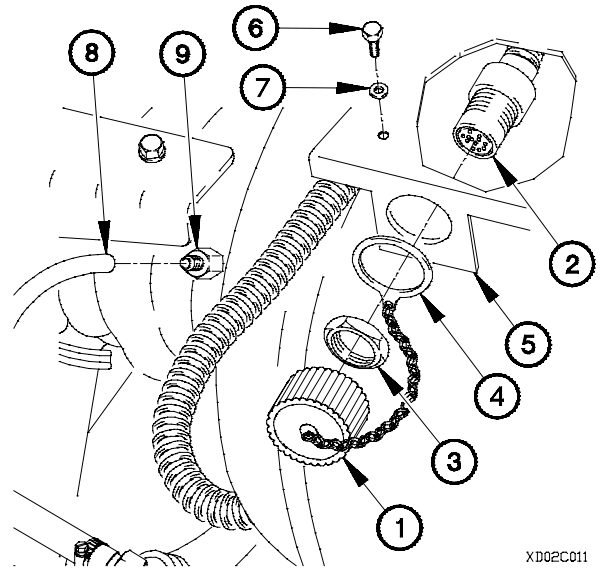

XD02C011

- (5) Loosen clamp (10) on particle extraction hose (11).
- (6) Remove particle extraction hose (11) from adapter (12).

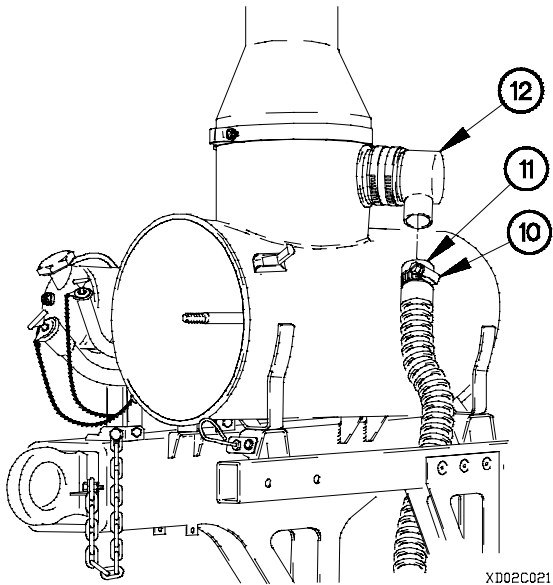

XD02C021

- (7) Loosen clamp (13) on air compressor intake hose (14).
- (8) Remove air compressor intake hose (14) from intake air cleaner boot (15).

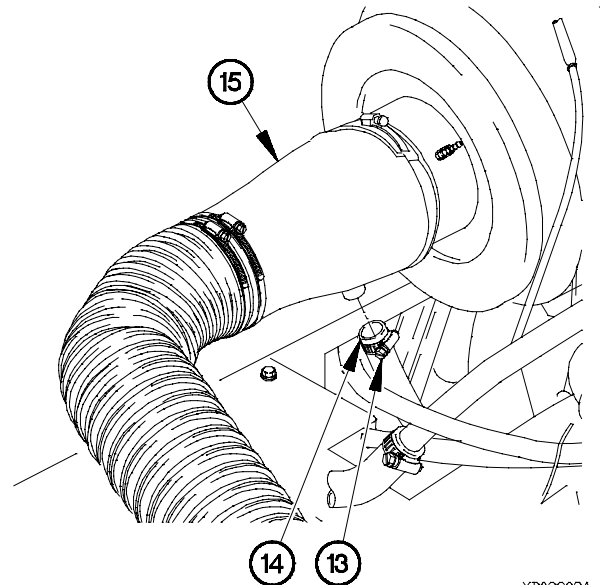

XD02C03A

- (9) Loosen clamp (16) on turbocharger intake hose (17).
- (10) Remove turbocharger intake hose (17) from intake air cleaner boot (15).

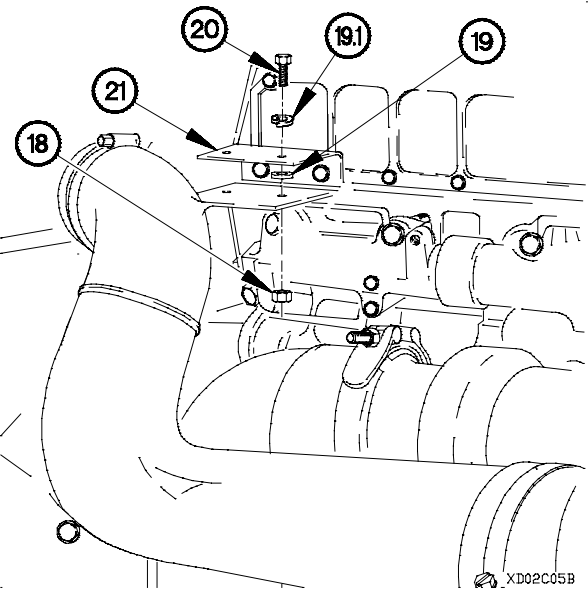
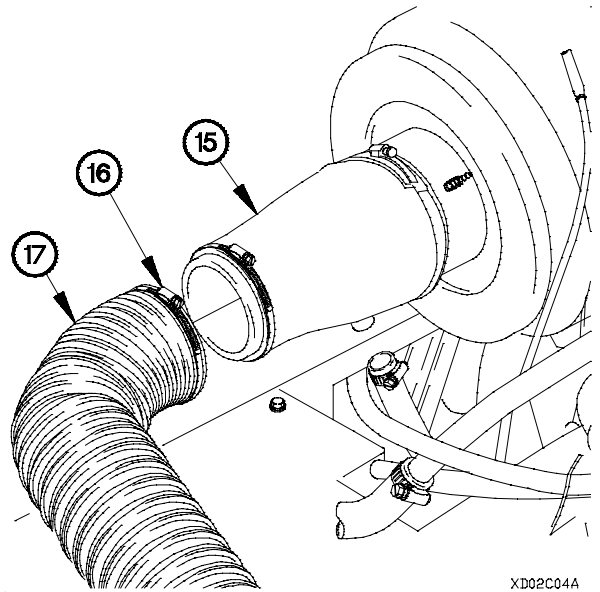

- (11) Remove two nuts (18), washers (19), lockwashers (19.1), and screws (20) from bracket (21). Discard lockwashers.

- (12) Remove two screws (22), washers (23), and bracket (21) from engine inlet manifold (24).

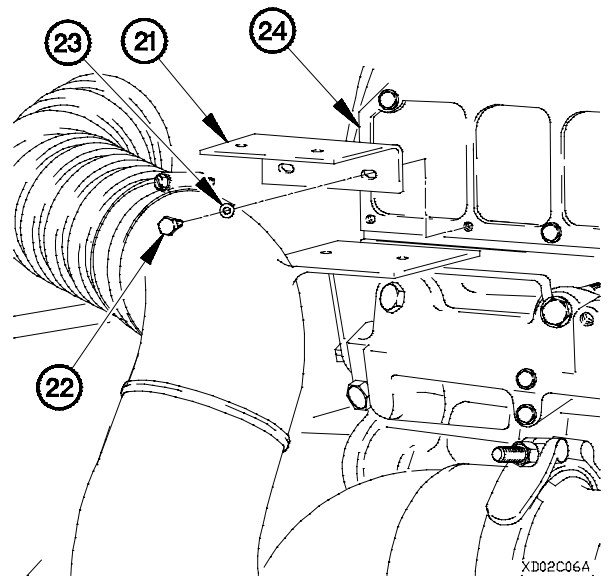

4-2. INTAKE AIR CLEANER FILTER ELEMENT, AIR CLEANER ASSEMBLY, AND PARTICLE EXTRACTION TUBE REPLACEMENT (CONT)

- (13) Loosen clamp (25) on turbocharger inlet coupling (26).
- (14) Remove turbocharger tube (27) from turbocharger inlet coupling (26).
- (15) Loosen clamp (28) on turbocharger inlet coupling (26).

CAUTION

Cover turbocharger inlet with wiping rags after removing turbocharger inlet coupling. Failure to comply may result in damage to equipment.

- (16) Remove turbocharger inlet coupling (26) from turbocharger (29).

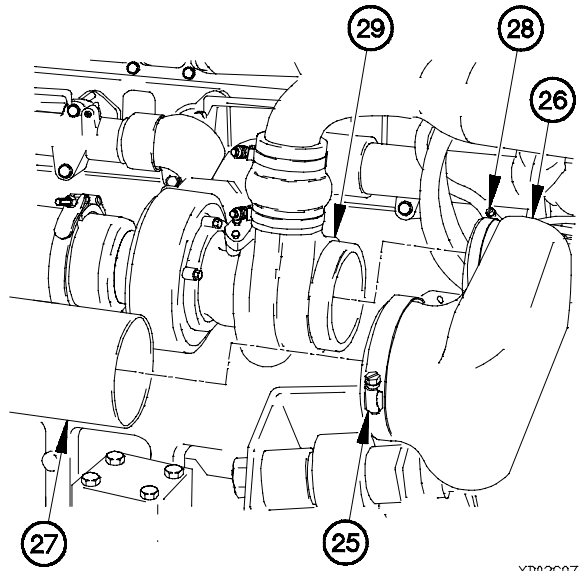

XD02C07A

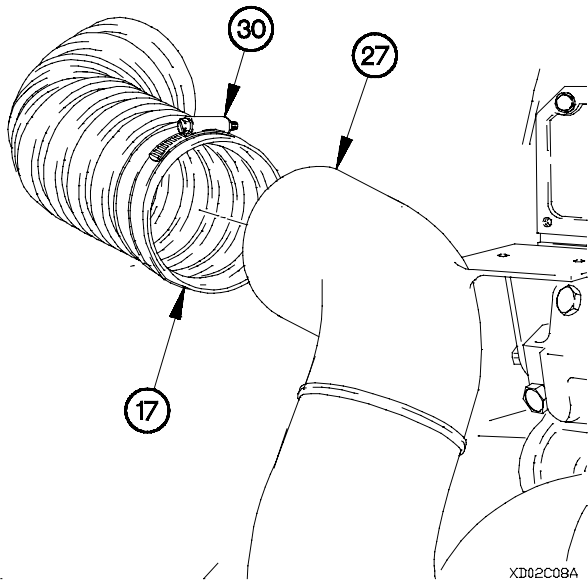

XD02C08A

- (17) Loosen clamp (30) on turbocharger intake hose (17).
- (18) Remove turbocharger intake hose (17) from turbocharger tube (27).

- (19) Remove screw (31) and washer (32) from resilient mount (33).
- (20) Remove three self-locking nuts (34) and screws (35) from mounting brackets (36). Discard self-locking nuts.
- (21) Remove intake air cleaner assembly (37) from three mounting brackets (36) and resilient mount (33).

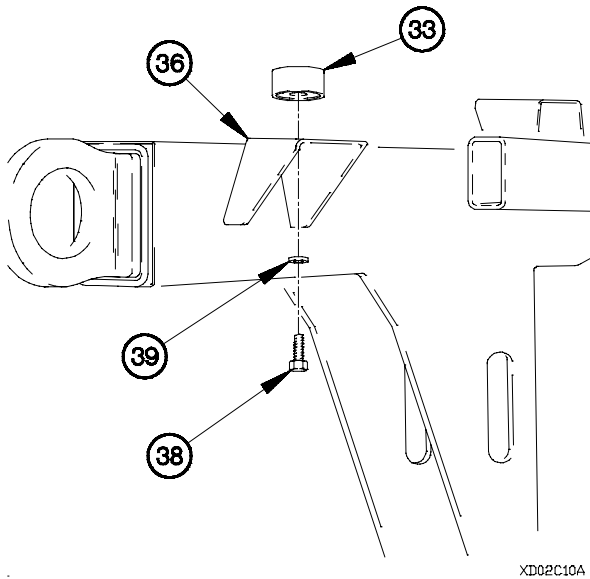
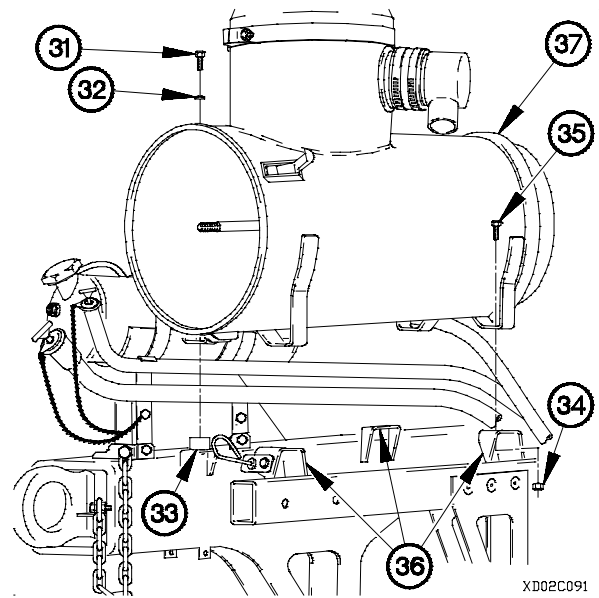

- (22) Remove screw (38), washer (39), and resilient mount (33) from mounting bracket (36).

d. M1093/M1094 Intake Air Cleaner Assembly Removal.

- (1) Remove dust cap (1) from connector J106 (2).
- (2) Remove nut (3), dust cap lanyard (4), and connector J106 (2) from chemical detector mounting bracket (5).
- (3) Remove four screws (6) and washers (7) from chemical detector mounting bracket (5).
- (4) Disconnect air filter restriction gauge hose (8) from air flow sensor (9).

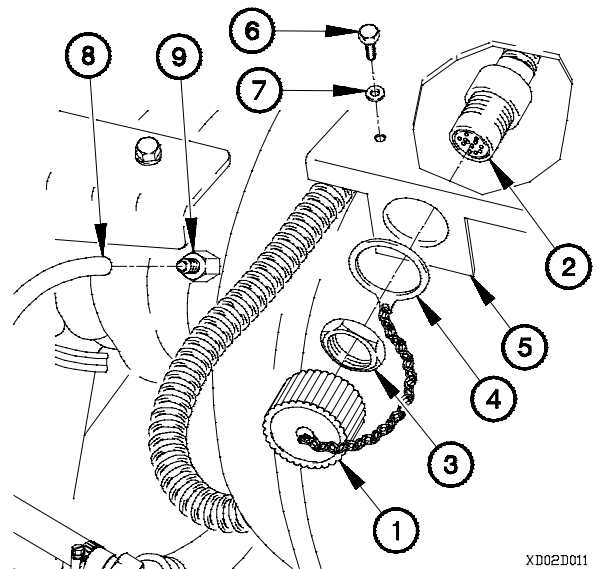

4-2. INTAKE AIR CLEANER FILTER ELEMENT, AIR CLEANER ASSEMBLY, AND PARTICLE EXTRACTION TUBE REPLACEMENT (CONT)

- (5) Loosen clamp (10) on particle extraction hose (11).
- (6) Remove particle extraction hose (11) from adapter (12).

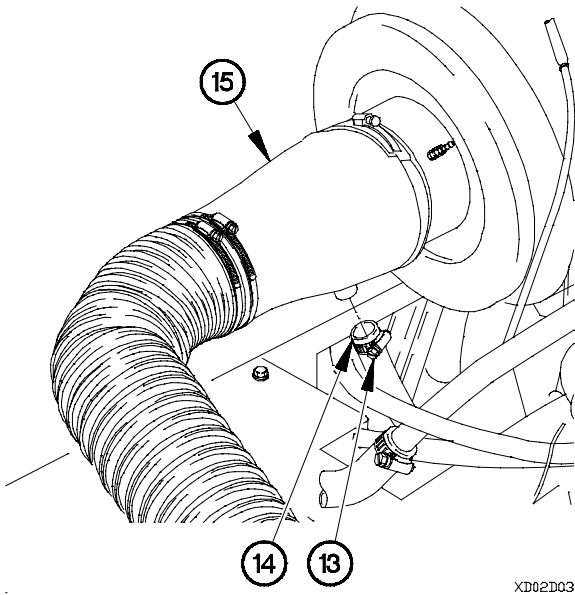
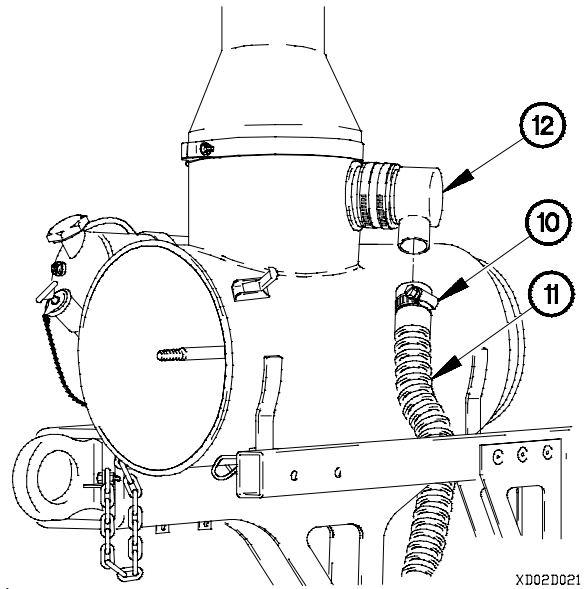

- (7) Loosen clamp (13) on air compressor intake hose (14).
- (8) Remove air compressor intake hose (14) from intake air cleaner boot (15).

- (9) Loosen clamp (16) on turbocharger intake hose (17).
- (10) Remove turbocharger intake hose (17) from intake air cleaner boot (15).

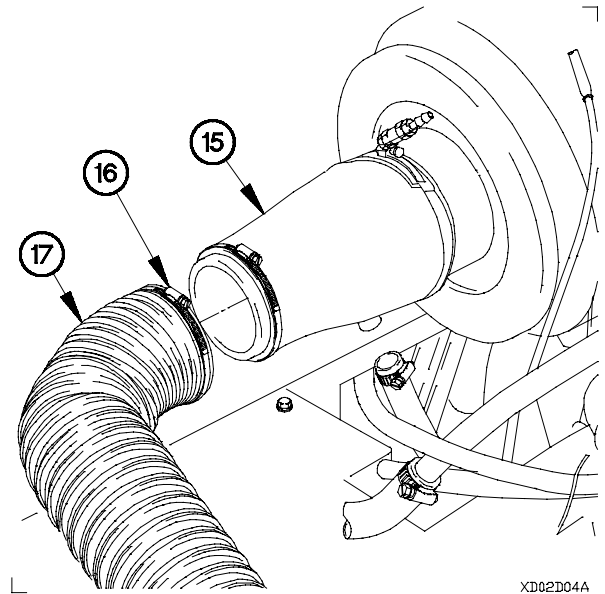

- (11) Remove two nuts (18), washers (19), lockwashers (19.1), and screws (20) from bracket (21). Discard lockwashers.

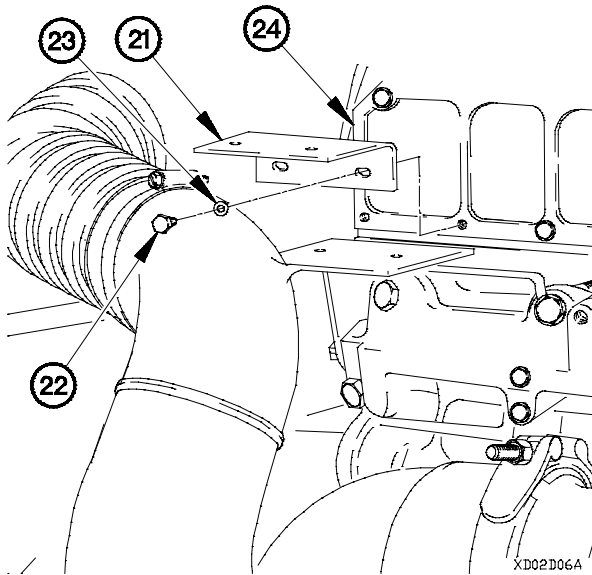
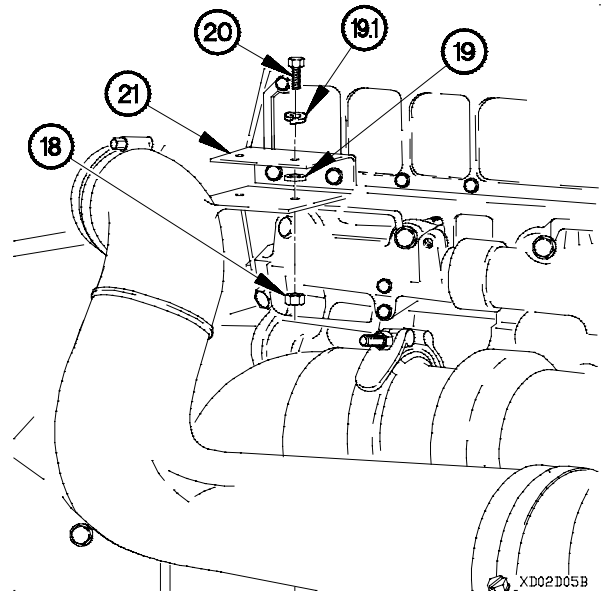

- (12) Remove two screws (22), washers (23), and bracket (21) from engine inlet manifold (24).

- (13) Loosen clamp (25) on turbocharger inlet coupling (26).
 (14) Remove turbocharger tube (27) from turbocharger inlet coupling (26).
 (15) Loosen clamp (28) on turbocharger inlet coupling (26).

CAUTION

Cover turbocharger inlet with wiping rags after removing turbocharger inlet coupling. Failure to comply may result in damage to equipment.

- (16) Remove turbocharger inlet coupling (26) from turbocharger (29).

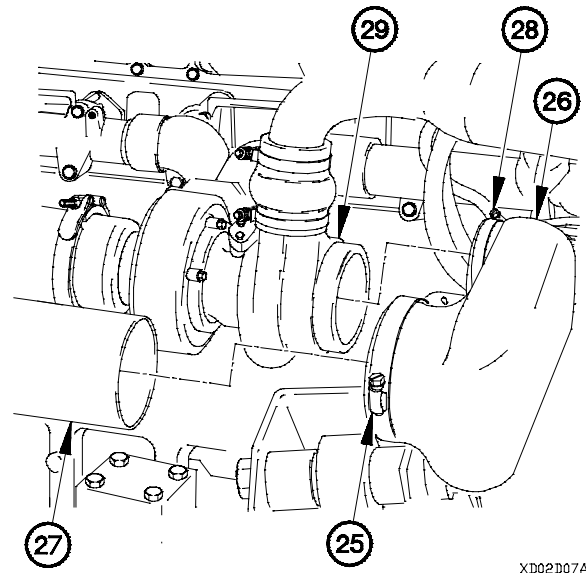

4-2. INTAKE AIR CLEANER FILTER ELEMENT, AIR CLEANER ASSEMBLY, AND PARTICLE EXTRACTION TUBE REPLACEMENT (CONT)

- (17) Loosen clamp (30) on turbocharger intake hose (17).
- (18) Remove turbocharger intake hose (17) from turbocharger tube (27).

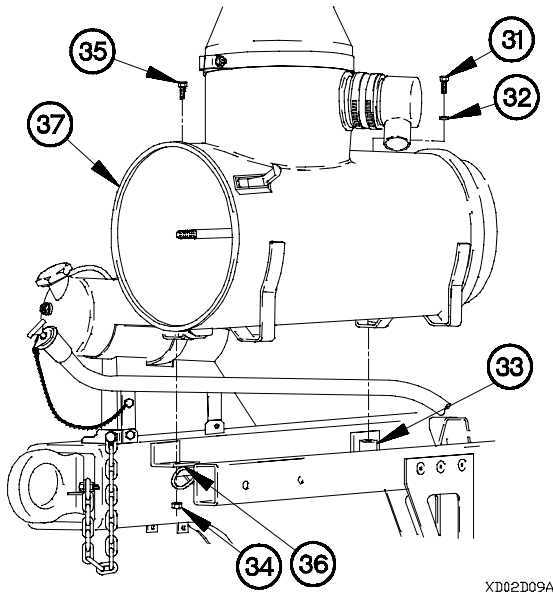
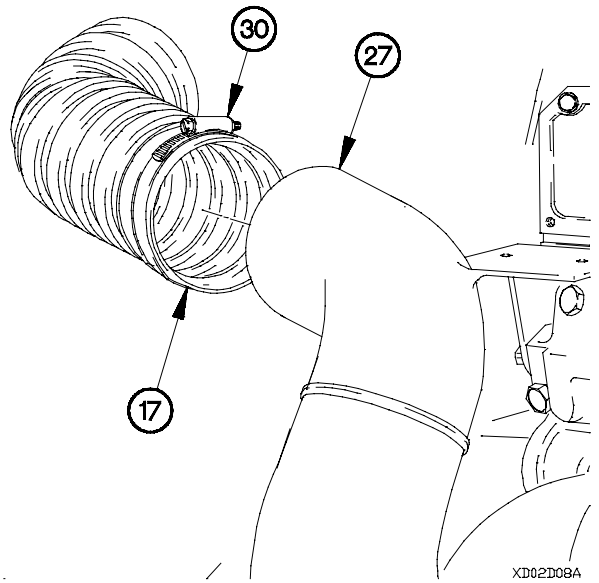

- (19) Remove screw (31) and washer (32) from resilient mount (33).
- (20) Remove three self-locking nuts (34) and screws (35) from mounting brackets (36). Discard self-locking nuts.
- (21) Remove intake air cleaner assembly (37) from mounting brackets (36) and resilient mount (33).

- (22) Remove screw (38), washer (39), and resilient mount (33) from mounting bracket (36).

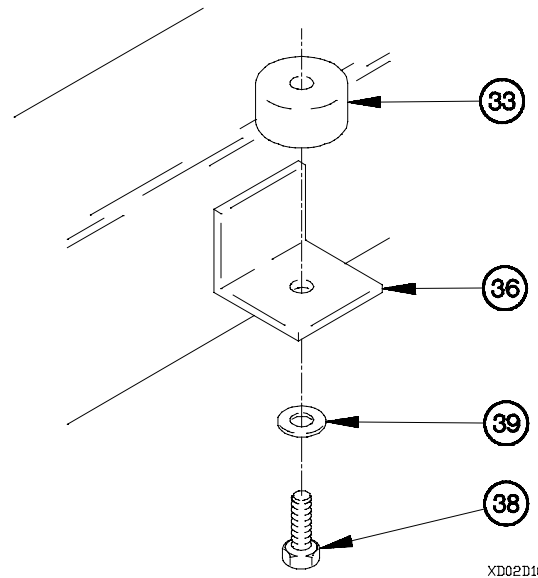

e. Intake Air Cleaner Disassembly.

- (1) Remove air flow sensor (1) from pipe coupling (2).
- (2) Remove pipe coupling (2) from intake air cleaner housing (3).
- (3) Loosen clamp (4) on intake air cleaner boot (5).
- (4) Remove intake air cleaner boot (5) from intake air cleaner housing (3).
- (5) Loosen clamp (6) on intake air cleaner boot (5).
- (6) Remove adapter (7) from intake air cleaner boot (5).

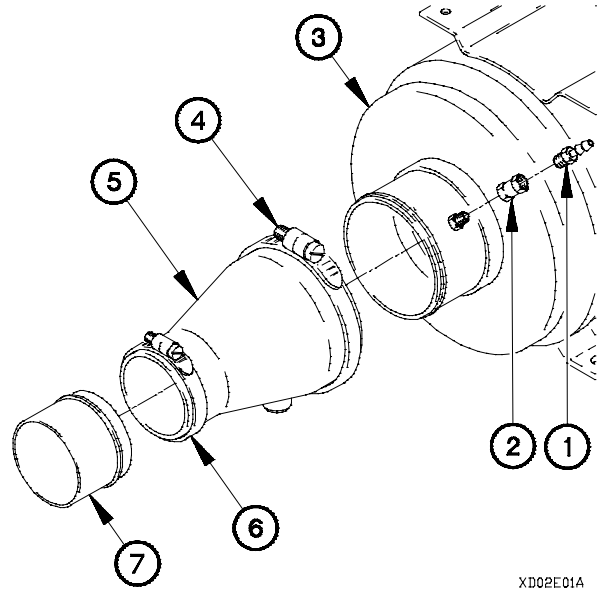

XD02E01A

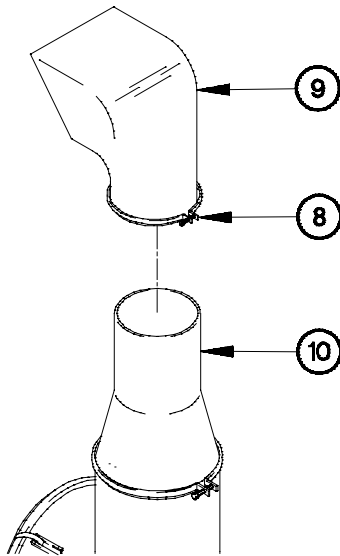

XD02E02B

NOTE

- Vehicles may be equipped with air intake adapters PN 12420527, PN 12421274, or PN 12421380. If air intake adapter PN 12420527 or PN 12421274 is damaged, replace with intake adapter PN 12421380 and clamp PN 12421379-001.
 - Perform step (9) on vehicles equipped with air intake adapter PN 12420572.
- (9) Remove self-locking nut (11), screw (11.1), and clamp (11.2) from air intake adapter (10). Discard self-locking nut.

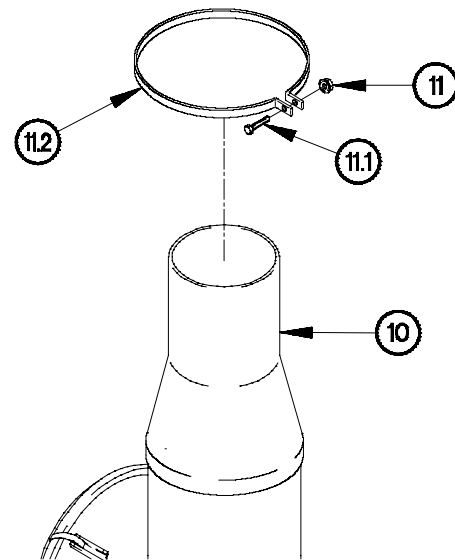

XD02E03B

4-2. INTAKE AIR CLEANER FILTER ELEMENT, AIR CLEANER ASSEMBLY, AND PARTICLE EXTRACTION TUBE REPLACEMENT (CONT)

NOTE

Perform step (10) on vehicles equipped with air intake adapter PN 12421274.

- (10) Remove self-locking nut (11) and screw (11.1) from band (11.2). Discard self-locking nut.

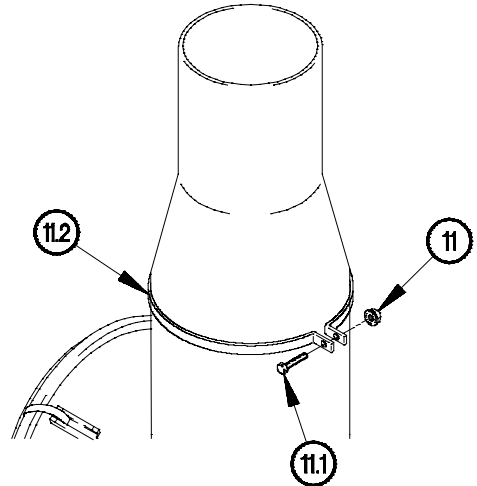

XD02E04B

NOTE

Perform step (10.1) on vehicles equipped with air intake adapter PN 12421380.

- (10.1) Remove self-locking nut (11) and clamp (11.2) from air intake adapter (10). Discard self-locking nut.
- (10.2) Remove air intake adapter (10) from intake air cleaner housing (3).

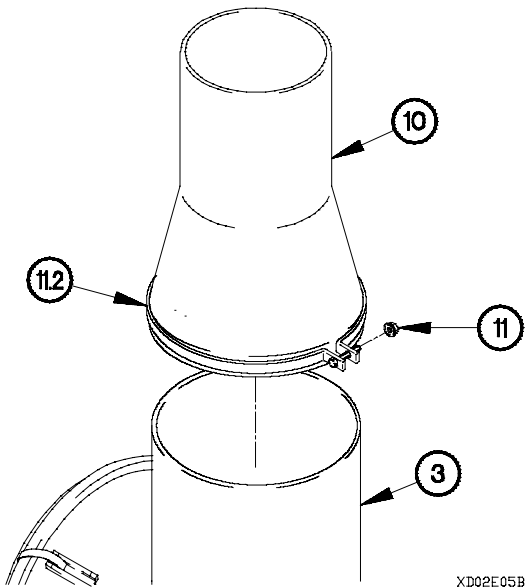

XD02E05B

- (11) Loosen clamp (12) on resilient mount (13).
- (12) Remove resilient mount (13) from intake air cleaner housing (3).
- (13) Loosen clamp (14) on resilient mount (13).
- (14) Remove adapter (15) from resilient mount (13).

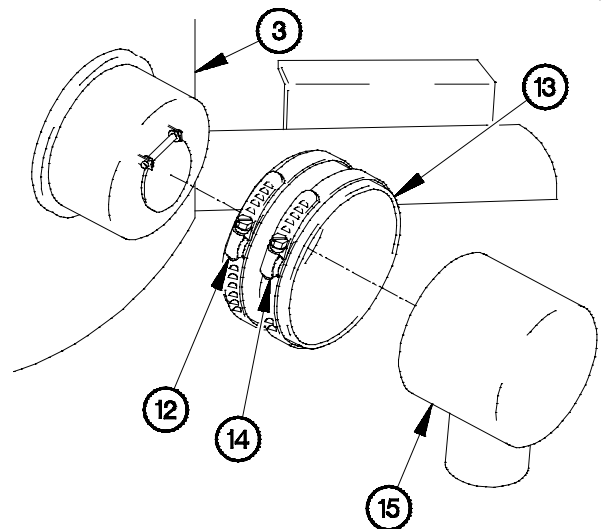

XD02E06B

(15) Remove pin (16), air shutter (17), and gasket (18) from intake air cleaner housing (3). Discard gasket.

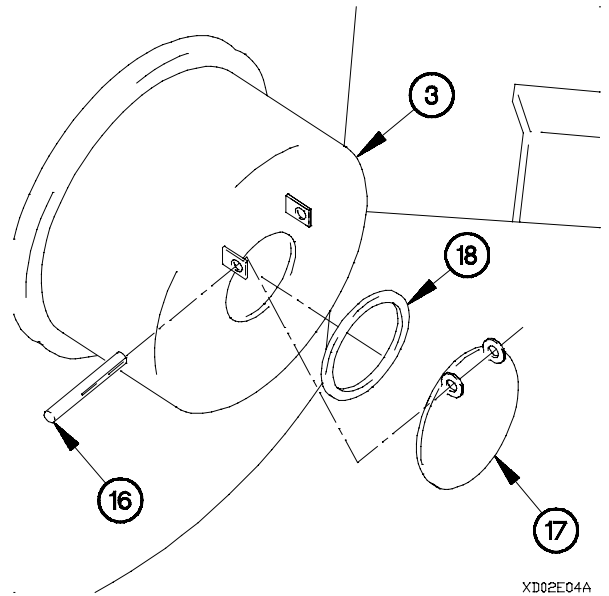

XD02E04A

f. Intake Air Cleaner Assembly.

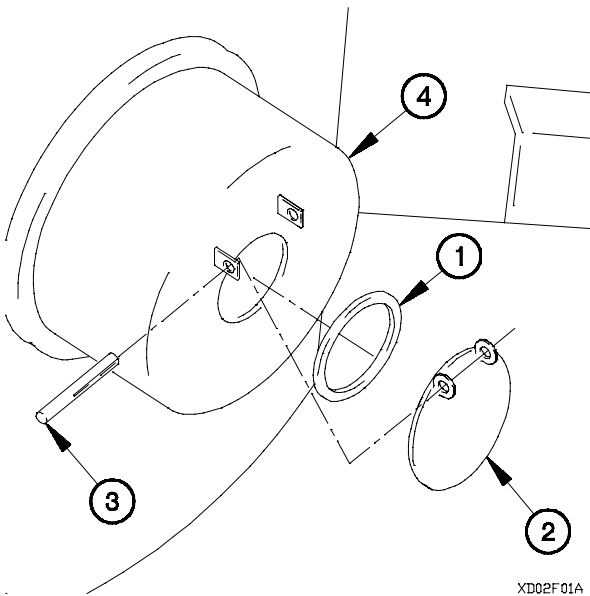

XD02F01A

(1) Install gasket (1), air shutter (2), and pin (3) in intake air cleaner housing (4).

(2) Install adapter (5) on resilient mount (6) with clamp (7).

(3) Install resilient mount (6) on intake air cleaner housing (4) with clamp (8).

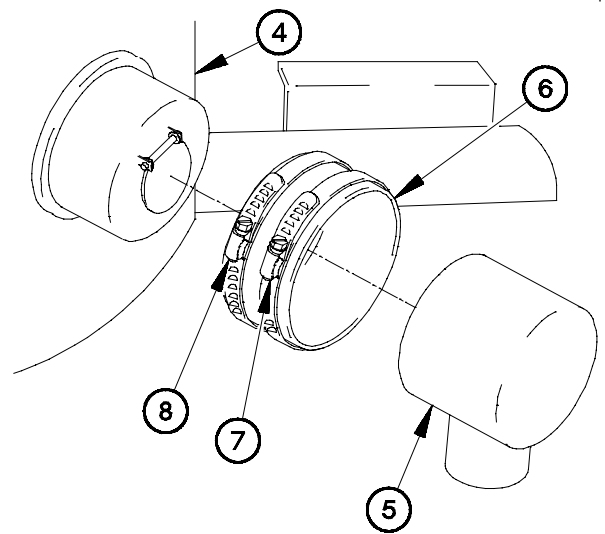

XD02F02A

4-2. INTAKE AIR CLEANER FILTER ELEMENT, AIR CLEANER ASSEMBLY, AND PARTICLE EXTRACTION TUBE REPLACEMENT (CONT)

- (4) Position air intake adapter (9) on intake air cleaner housing (4).

NOTE

Perform steps (5) and (5.1) on vehicles equipped with air intake adapter PN 12421380.

- (5) Position clamp (10) on air intake adapter (9) with self-locking nut (10.1).

- (5.1) Tighten self-locking nut (10.1) to 6-8 lb-ft (10-11 N-m).

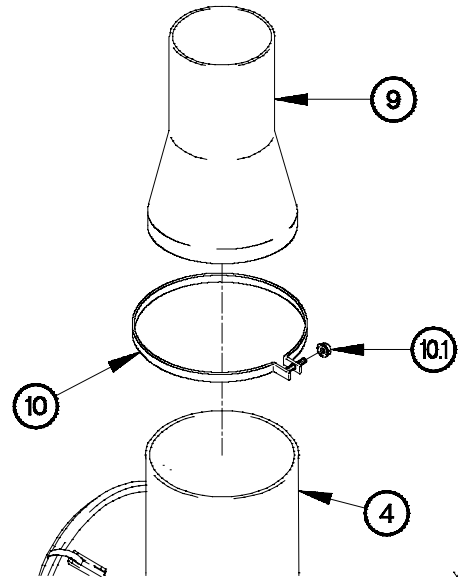

XD02F03B

NOTE

Perform steps (5.2) and (5.3) on vehicles equipped with air intake adapter PN 12421274.

- (5.2) Position screw (10.2) and self-locking nut (10.1) on band (10).

- (5.3) Tighten self-locking nut (10.1) to 33-39 lb-ft (44-54 N-m).

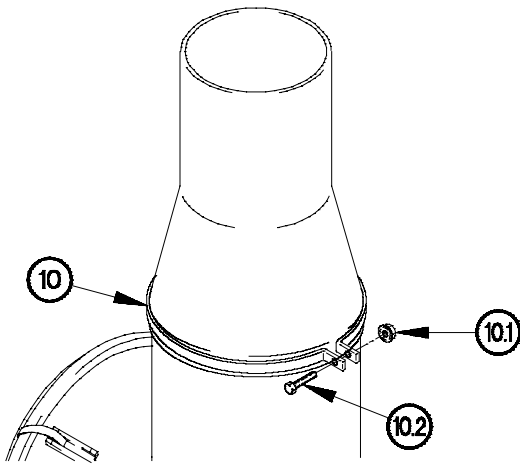

XD02F04B

NOTE

Perform steps (5.4) and (5.5) on vehicles equipped with air intake adapter PN 12420572.

- (5.4) Position clamp (10) on air intake adapter (9) with screw (10.2) and self-locking nut (10.1).

- (5.5) Tighten self-locking nut (10.1) to 33-39 lb-ft (44-54 N-m).

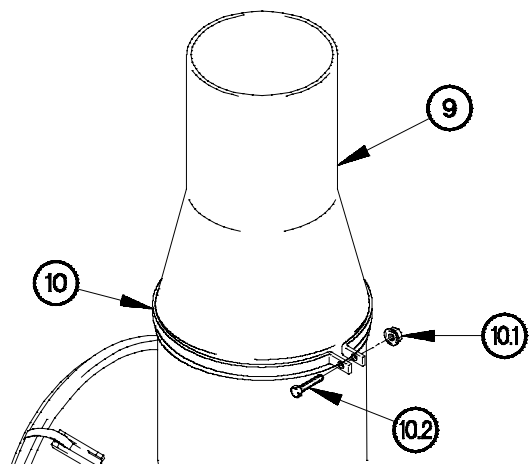

XD02F05B

- (6) Position air intake hood (11) on air intake adapter (9) with clamp (12).
- (7) Tighten clamp (12) to 72-96 lb-in. (8-11 N·m).

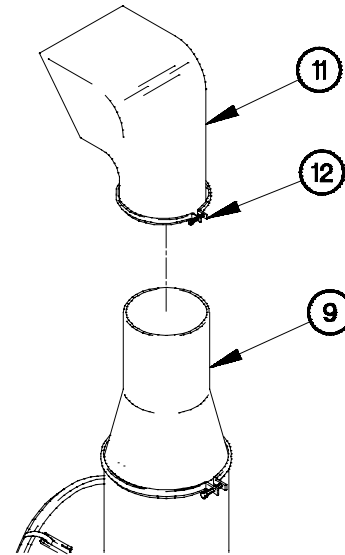

XD02F06B

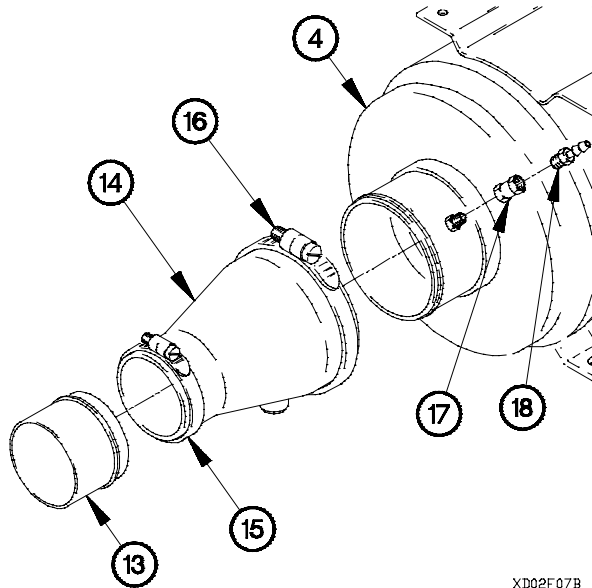

XD02F07B

- (8) Install adapter (13) in intake air cleaner boot (14) with clamp (15).
- (9) Position intake air cleaner boot (14) on intake air cleaner housing (4) with clamp (16).
- (10) Tighten clamp (16) to 36-48 lb-in. (4-5 N·m).
- (11) Install pipe coupling (17) in intake air cleaner housing (4).
- (12) Install air flow sensor (18) in pipe coupling (17).

g. M1093/M1094 Intake Air Cleaner Assembly Installation.

- (1) Position washer (1), screw (2), and resilient mount (3) on mounting bracket (4).
- (2) Tighten screw (2) to 40-46 lb-ft (54-62 N·m).

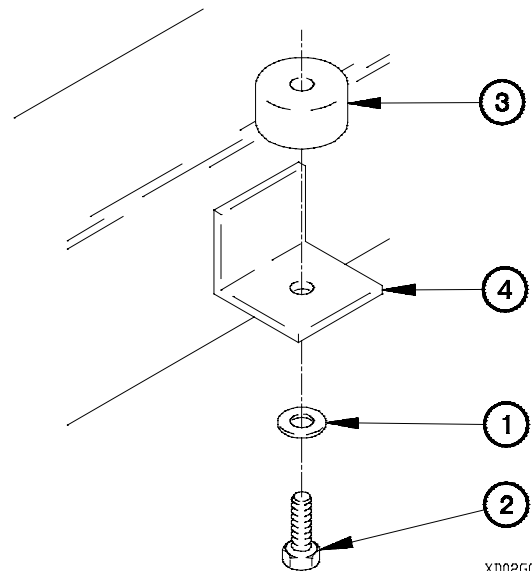

XD02G01A

4-2. INTAKE AIR CLEANER FILTER ELEMENT, AIR CLEANER ASSEMBLY, AND PARTICLE EXTRACTION TUBE REPLACEMENT (CONT)

- (3) Position intake air cleaner assembly (5) on mounting brackets (4).
- (4) Position washer (6) and screw (7) in resilient mount (3).
- (5) Position three screws (8) and self-locking nuts (9) in mounting brackets (4).
- (6) Tighten screw (7) to 40-52 lb-ft (54-70 N·m).
- (7) Tighten three self-locking nuts (9) to 40-52 lb-ft (54-70 N·m).

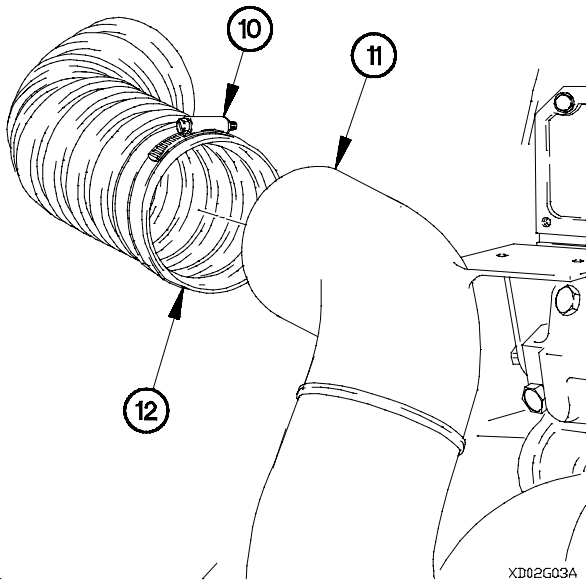
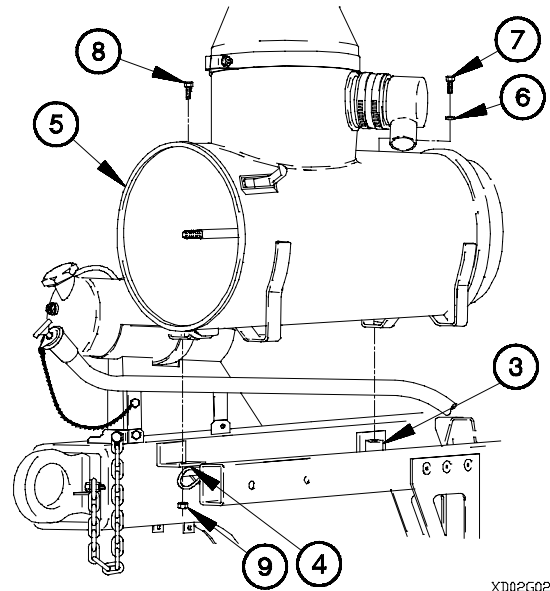

- (8) Position turbocharger intake hose (10) on turbocharger tube (11) with clamp (12).
- (9) Tighten clamp (12) to 36-48 lb-in. (4-5 N·m).

CAUTION

Distance between front edge of air duct and alternator fan shroud must be no less than 0.5 in. (1.27 cm). Failure to comply may result in damage to equipment.

- (10) Position air duct (13) on turbocharger (14) with clamp (15).
- (11) Tighten clamp (15) to 21-25 lb-in. (2-3 N·m).
- (12) Position turbocharger tube (11) in air duct (13) with clamp (16).
- (13) Tighten clamp (16) to 36-48 lb-in. (4-5 N·m).

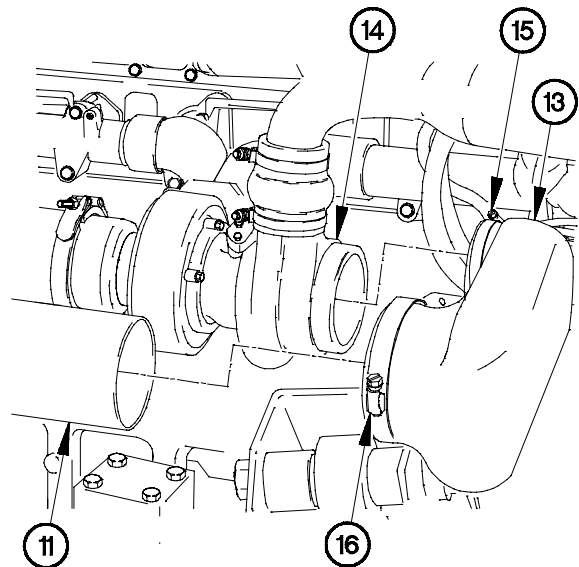

(14) Position bracket (17) on engine inlet manifold (18) with two washers (19) and screws (20).

(15) Tighten two screws (20) to 15-25 lb-ft (20-34 N·m).

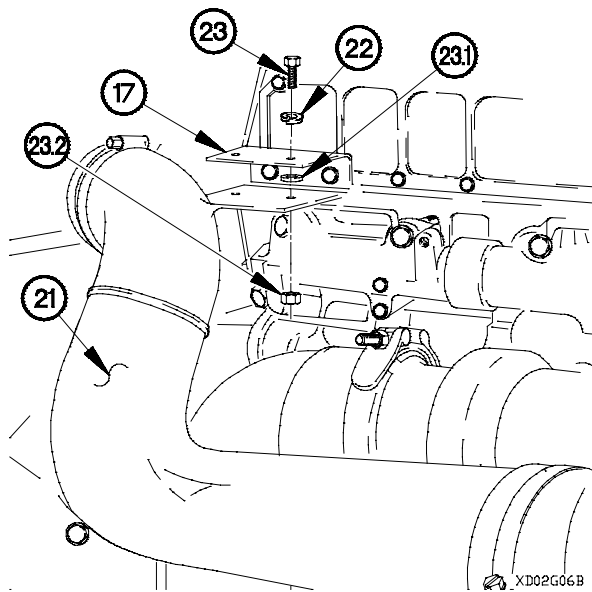
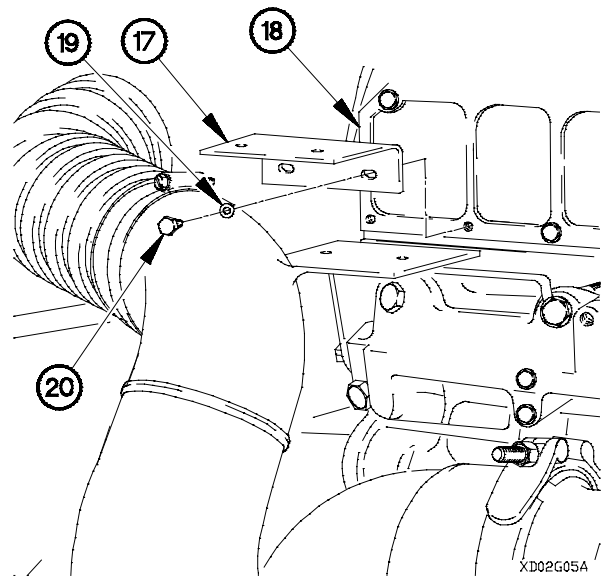

(16) Position intake tube (21) on bracket (17) with two lockwashers (22), screws (23), washers (23.1) and nuts (23.2).

(17) Tighten two nuts (23.2) to 22-26 lb-ft (29-35 N·m).

(18) Position turbocharger intake hose (10) on intake air cleaner boot (24) with clamp (25).

(19) Tighten clamp (25) to 36-48 lb-in. (4-5 N·m).

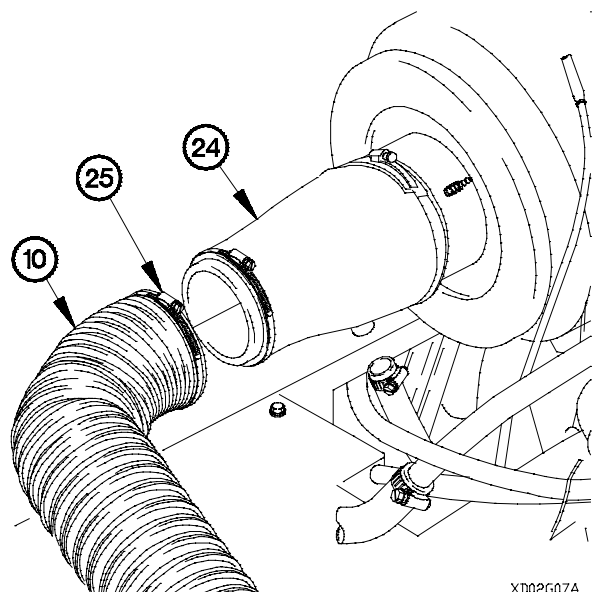

4-2. INTAKE AIR CLEANER FILTER ELEMENT, AIR CLEANER ASSEMBLY, AND PARTICLE EXTRACTION TUBE REPLACEMENT (CONT)

- (20) Position air compressor intake hose (26) on intake air cleaner boot (24) with clamp (27).
- (21) Tighten clamp (27) to 36-48 lb-in. (4-5 N·m).

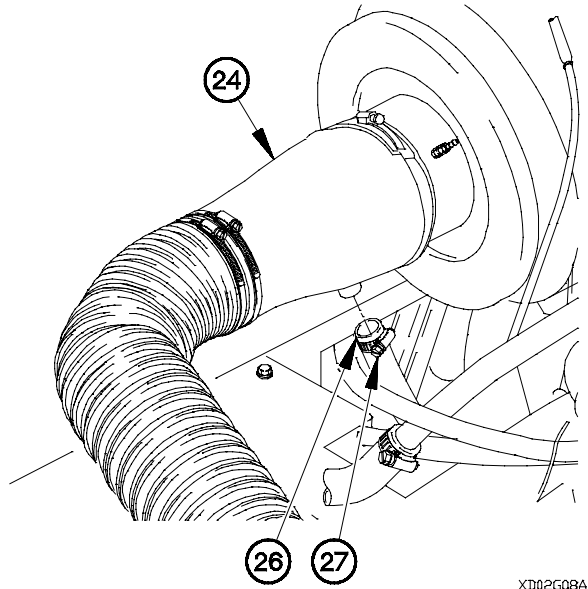

XD02G08A

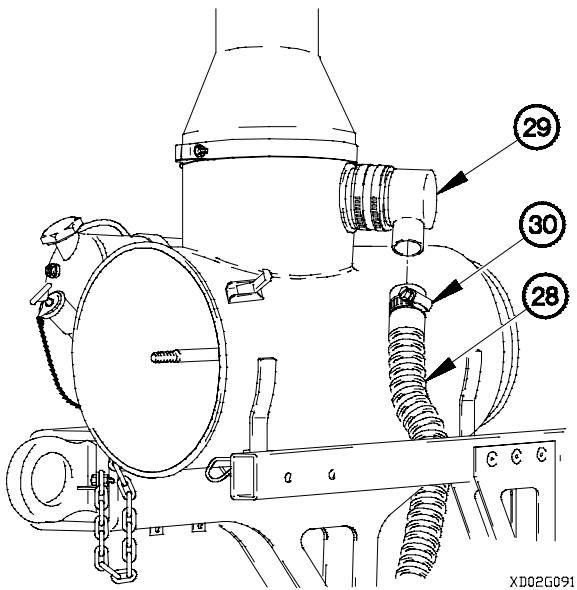

XD02G091

- (22) Position particle extraction hose (28) on adapter (29) with clamp (30).
- (23) Tighten clamp (30) to 36-48 lb-in. (4-5 N·m).

- (24) Connect air filter restriction gauge hose (31) to air flow sensor (32).
- (25) Install connector J106 (33) and dust cap lanyard (34) on chemical detector mounting bracket (35) with nut (36).
- (26) Install dust cap (37) on connector J106 (33).
- (27) Install four washers (38) and screws (39) in chemical detector mounting bracket (35).

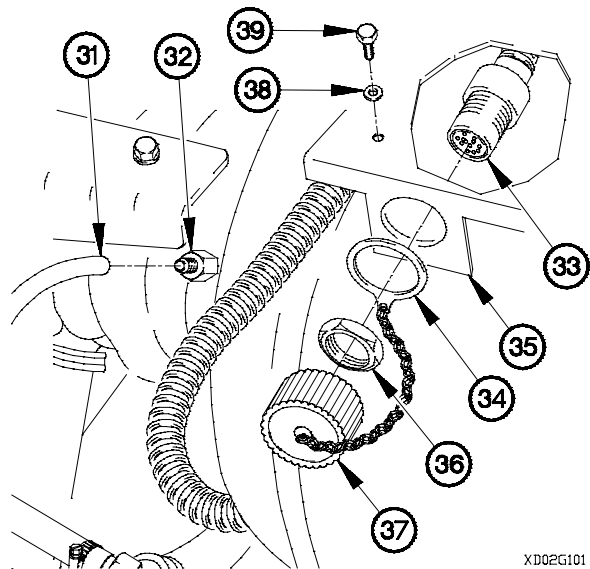

XD02G101

h. Intake Air Cleaner Assembly Installation (All Models Except M1093/M1094).

- (1) Position washer (1), screw (2), and resilient mount (3) on mounting bracket (4).
- (2) Tighten screw (2) to 40-52 lb-ft (54-70 N·m).

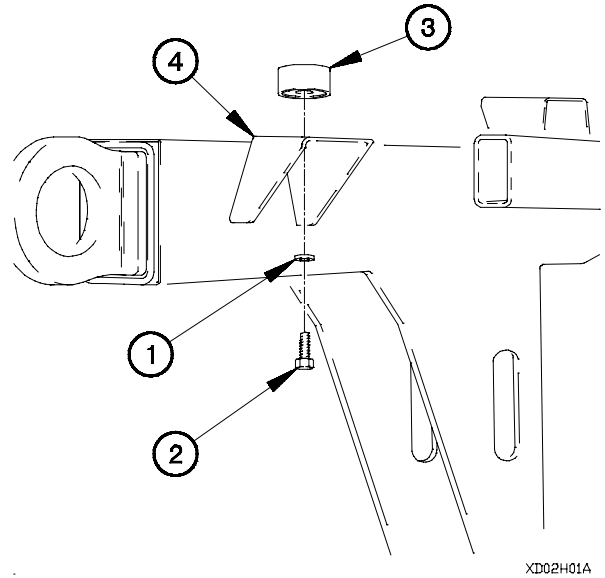

- (3) Position intake air cleaner housing (5) on mounting brackets (4).
- (4) Position washer (6) and screw (7) in resilient mount (3).
- (5) Position three screws (8) and self-locking nuts (9) in mounting brackets (4).
- (6) Tighten screw (7) to 50-52 lb-ft (54-70 N·m).
- (7) Tighten three self-locking nuts (9) to 43-52 lb-ft (58-70 N·m).

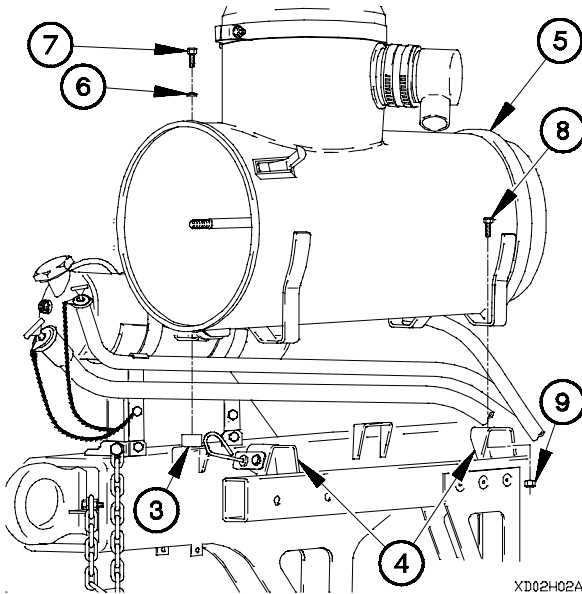

- (8) Position turbocharger intake hose (10) on turbocharger tube (11) with clamp (12).
- (9) Tighten clamp (12) to 36-48 lb-in. (4-5 N·m).

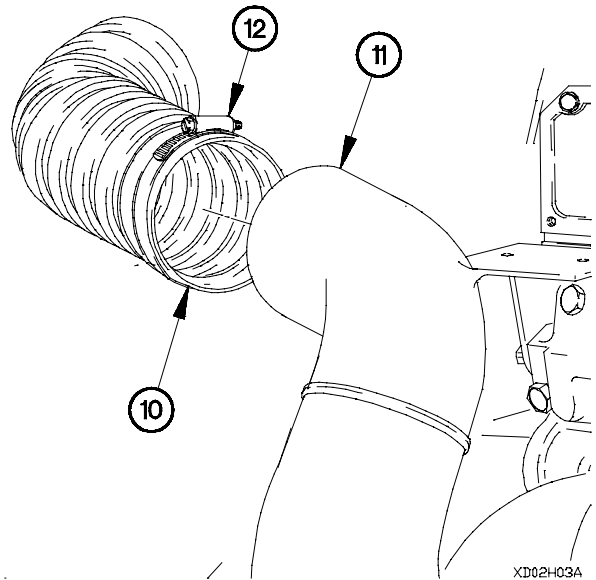

4-2. INTAKE AIR CLEANER FILTER ELEMENT, AIR CLEANER ASSEMBLY, AND PARTICLE EXTRACTION TUBE REPLACEMENT (CONT)

CAUTION

Distance between front edge of air duct and alternator fan shroud must be no less than 0.5 in. (1.27 cm). Failure to comply may result in damage to equipment.

- (10) Position air duct (13) on turbocharger (14) with clamp (15).
- (11) Tighten clamp (15) to 21-25 lb-in. (2-3 N·m).
- (12) Position turbocharger tube (11) in air duct (13) with clamp (16).
- (13) Tighten clamp (16) to 36-48 lb-in. (4-5 N·m).

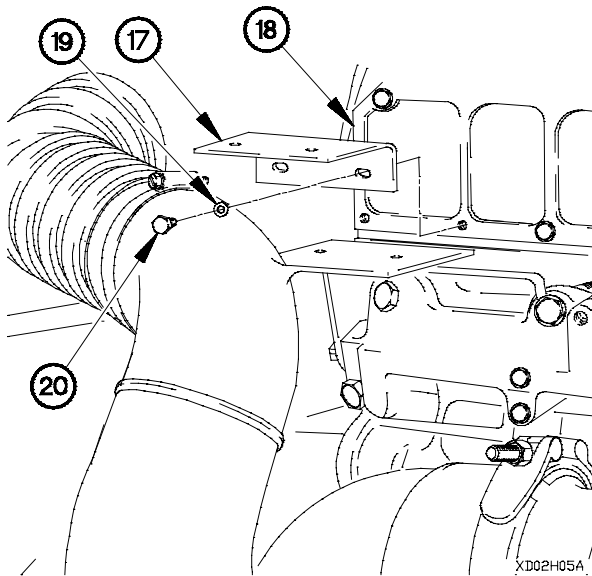
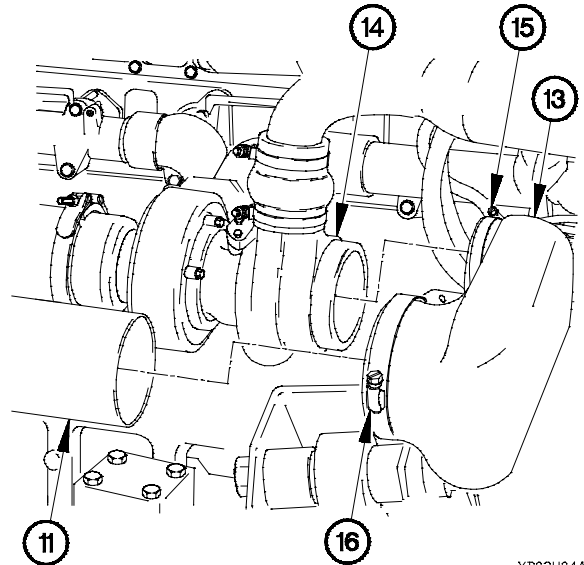

- (14) Position bracket (17) on engine inlet manifold (18) with two washers (19) and screws (20).
- (15) Tighten two screws (20) to 15-25 lb-ft (20-34 N·m).

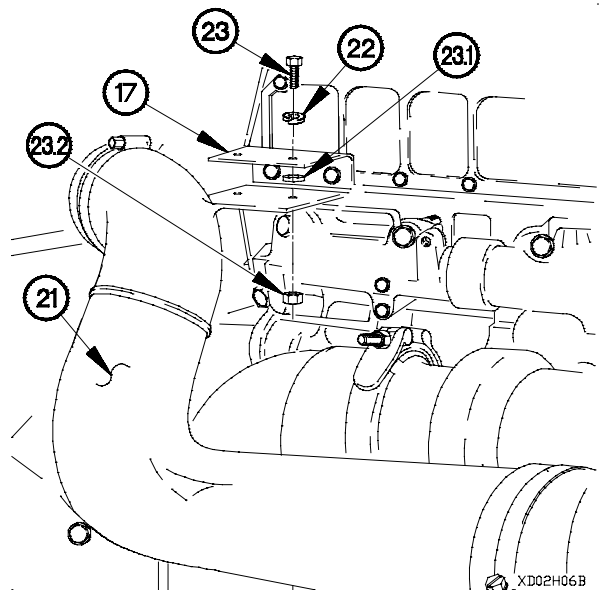

- (16) Position intake tube (21) on bracket (17) with two lockwashers (22), screws (23), washers (23.1) and nuts (23.2).
- (17) Tighten two nuts (23.2) to 22-26 lb-ft (29-35 N·m).

(18) Position turbocharger intake hose (10) on intake air cleaner boot (24) with clamp (25).

(19) Tighten clamp (25) to 36-48 lb-in. (4-5 N·m).

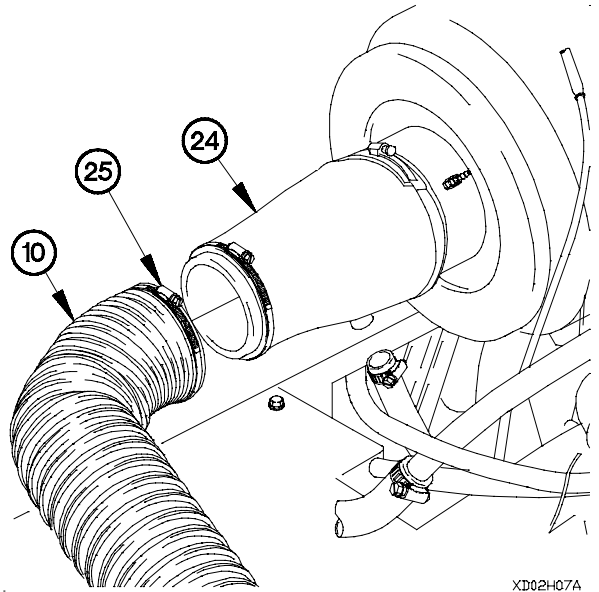

XD02H07A

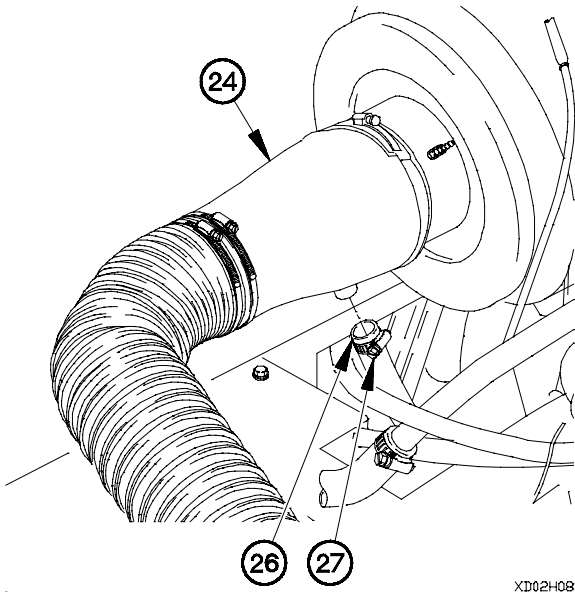

XD02H08A

(20) Position air compressor intake hose (26) on intake air cleaner boot (24) with clamp (27).

(21) Tighten clamp (27) to 36-48 lb-in. (4-5 N·m).

(22) Position particle extraction hose (28) on adapter (29) with clamp (30).

(23) Tighten clamp (30) to 36-48 lb-in. (4-5 N·m).

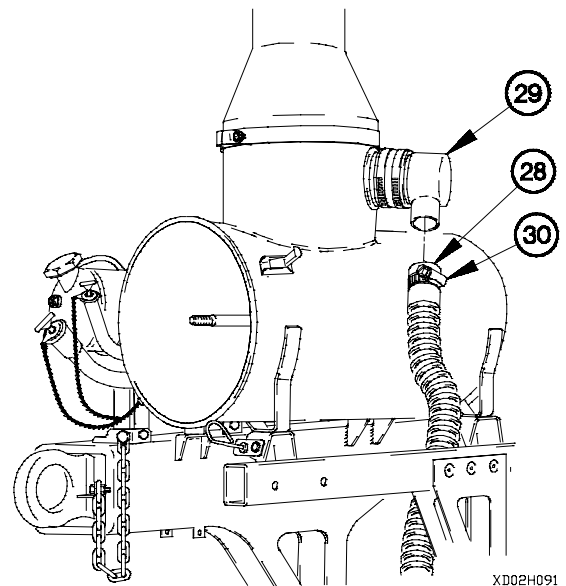

XD02H091

4-2. INTAKE AIR CLEANER FILTER ELEMENT, AIR CLEANER ASSEMBLY, AND PARTICLE EXTRACTION TUBE REPLACEMENT (CONT)

- (24) Connect air filter restriction gauge hose (31) to air flow sensor (32).
- (25) Install connector J106 (33) and dust cap lanyard (34) on chemical detector mounting bracket (35) with nut (36).
- (26) Install dust cap (37) on connector J106 (33).
- (27) Install four washers (38) and screws (39) in chemical detector mounting bracket (35).

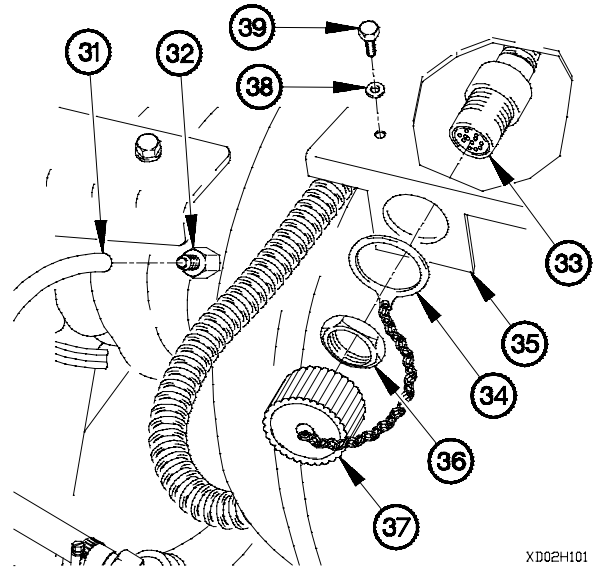

XD02H101

i. Particle Extraction Tube Removal.

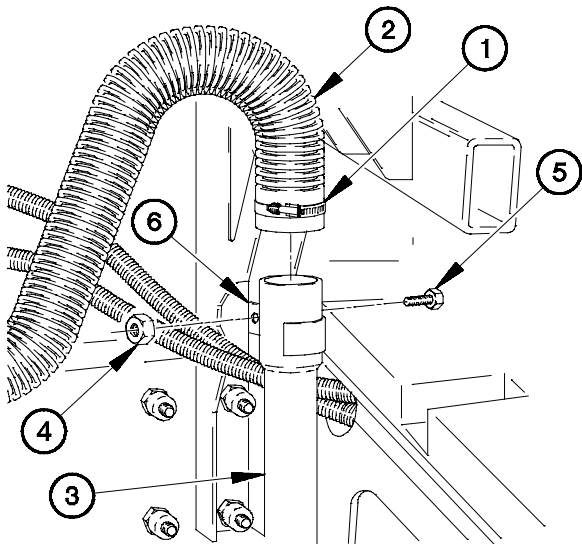

XD02I01A

- (1) Loosen clamp (1) on particle extraction hose (2).
- (2) Remove particle extraction hose (2) from particle extraction tube (3).
- (3) Remove self-locking nut (4) and screw (5) from bracket (6). Discard self-locking nut.

- (4) Loosen two clamps (7) on particle extraction hose (8).
- (5) Remove particle extraction hose (8) from particle extraction tube (3) and tailpipe (9).

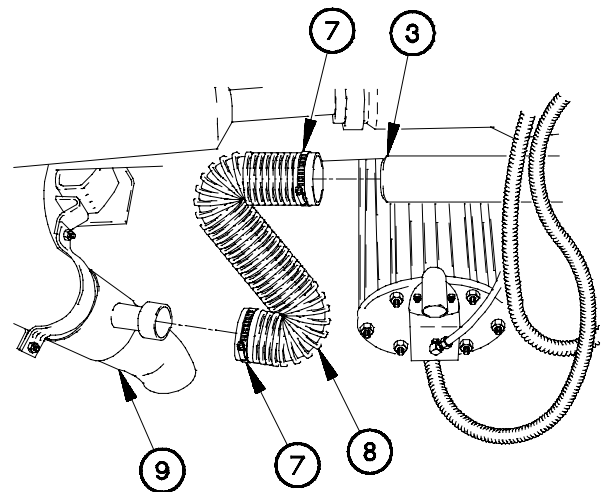

XD02I02A

- (6) Remove self-locking nut (10), screw (11), and clamp (12) from clamp (13). Discard self-locking nut.

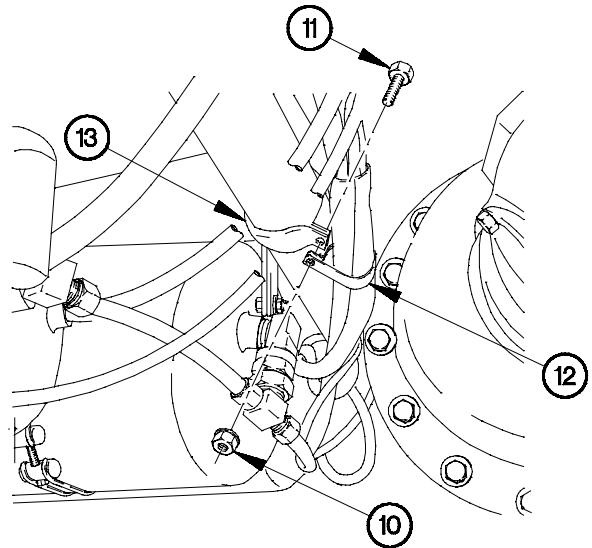

XD02I03A

- (7) Remove self-locking nut (14) from screw (15). Discard self-locking nut.

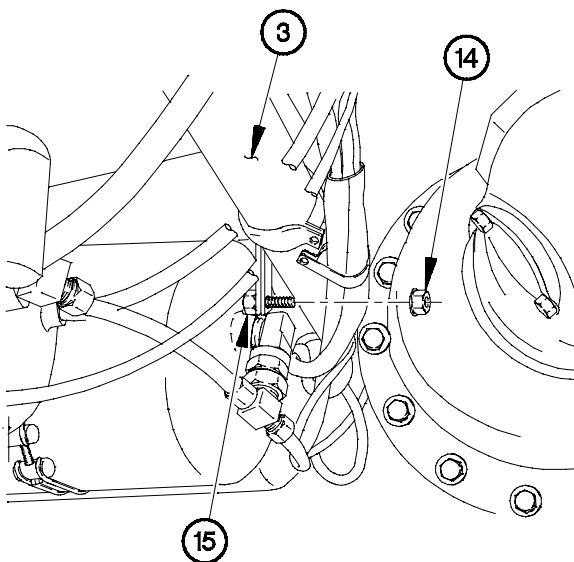

XD02I04A

CAUTION

Use care when removing particle extraction tube from vehicle. Failure to comply may result in damage to equipment.

NOTE

- Step (8) requires the aid of an assistant.
 - Remove particle extraction tube toward front of vehicle.
- (8) Remove particle extraction tube (3) from vehicle.

4-2. INTAKE AIR CLEANER FILTER ELEMENT, AIR CLEANER ASSEMBLY, AND PARTICLE EXTRACTION TUBE REPLACEMENT (CONT)

(9) Remove self-locking nut (16), screw (17), bracket (18), and screw (15) from vehicle. Discard self-locking nut.

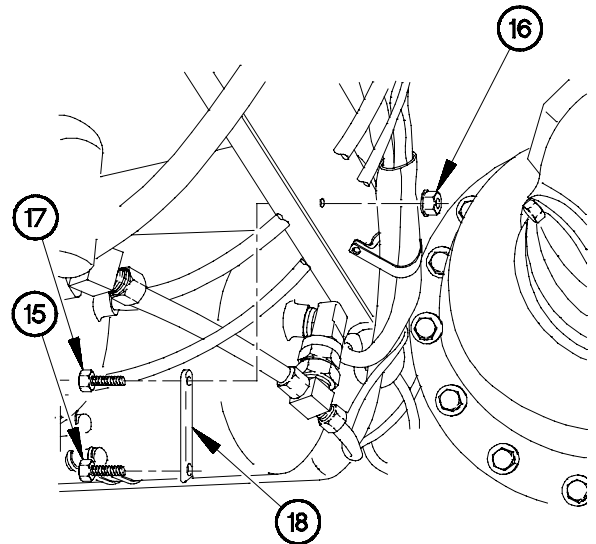

XD02I05A

j. Particle Extraction Tube Installation.

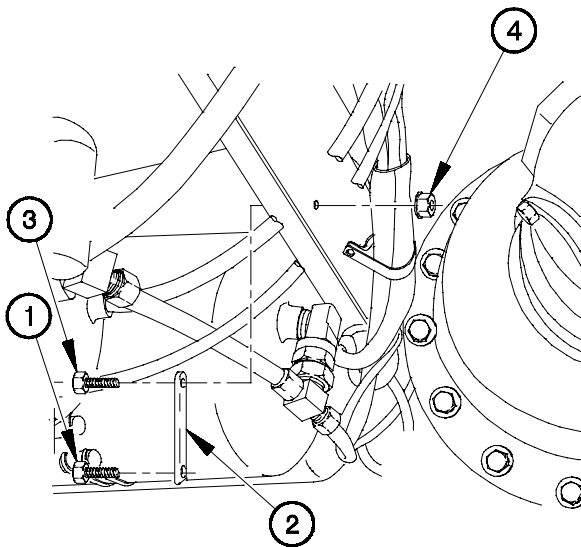

XD02J01A

(1) Position screw (1), bracket (2), screw (3), and self-locking nut (4) on vehicle.

NOTE

Steps (2) through (5) require the aid of an assistant.

(2) Tighten self-locking nut (4) to 46-58 lb-ft (62-79 N·m).

CAUTION

Use care when installing particle extraction tube on vehicle. Failure to comply may result in damage to equipment.

NOTE

Install particle extraction tube from front of vehicle.

- (3) Position particle extraction tube (5) on vehicle.
- (4) Position self-locking nut (6) on screw (1).
- (5) Tighten self-locking nut (6) to 46-58 lb-ft (62-79 N·m).

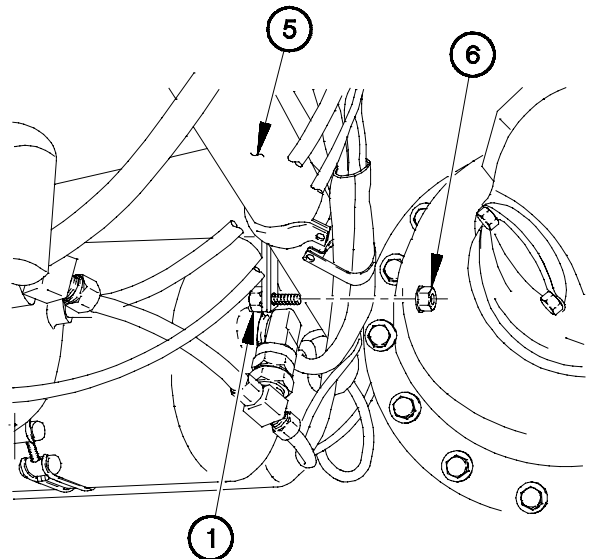

XD02J02A

- (6) Position clamp (7) on clamp (8) with screw (9) and self-locking nut (10).
- (7) Tighten self-locking nut (10) to 46-58 lb-ft (62-79 N·m).

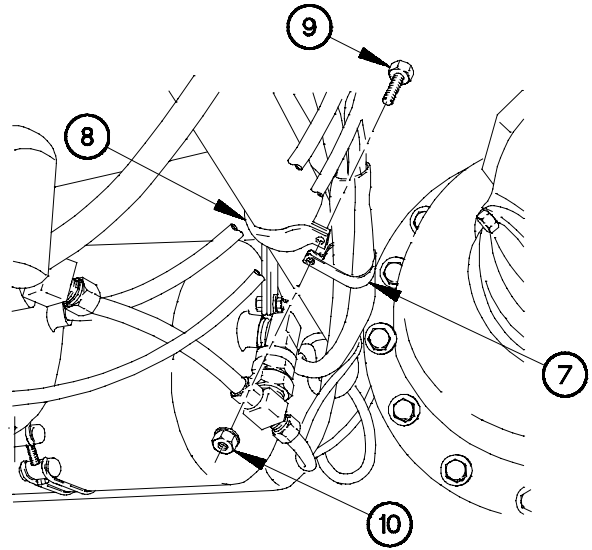

XD02.J03A

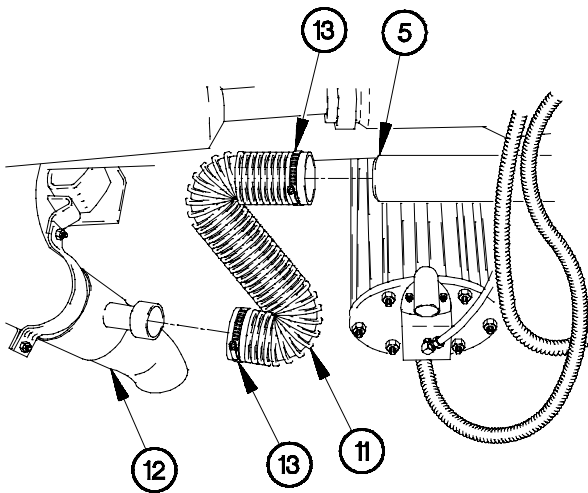

XD02.J04A

- (8) Position particle extraction hose (11) on tailpipe (12) and particle extraction tube (5) with two clamps (13).
- (9) Tighten clamp (13) to 36-48 lb-in. (4-5 N·m).

- (10) Position screw (14) and self-locking nut (15) on bracket (16).
- (11) Tighten self-locking nut (15) to 46-58 lb-ft (62-79 N·m).
- (12) Position particle extraction hose (17) on particle extraction tube (5) with clamp (18).
- (13) Tighten clamp (18) to 36-48 lb-in. (4-5 N·m).

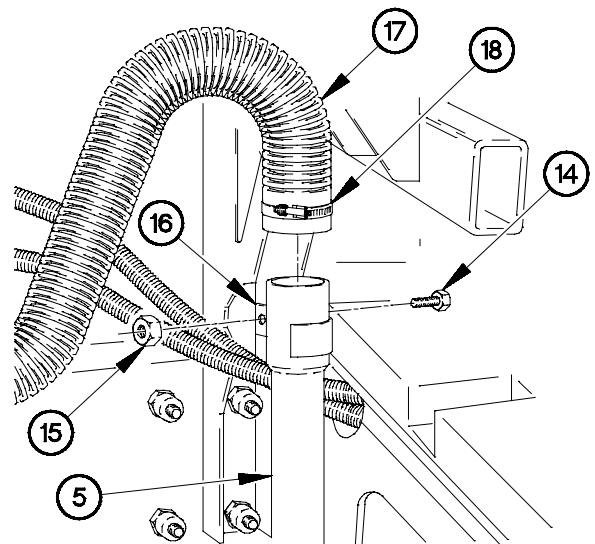

XD02.J05A

4-2. INTAKE AIR CLEANER FILTER ELEMENT, AIR CLEANER ASSEMBLY, AND PARTICLE EXTRACTION TUBE REPLACEMENT (CONT)

k. Follow-On Maintenance.

- (1) Install transmission oil fill tube (M1093/M1094) (para 8-22).
- (2) Install chemical detection unit, if equipped (TM 3-6665-225-12).
- (3) Connect batteries (para 7-57).
- (4) Lower cab (TM 9-2320-366-10-1).
- (5) Start engine (TM 9-2320-366-10-1).
- (6) Check for air leaks around hose and tube connections.
- (7) Check AIR FILTER RESTRICTION GAUGE (TM 9-2320-366-10-1).
- (8) Shut down engine (TM 9-2320-366-10-1).

End of Task.

4-3. FUEL PRESSURE REGULATING VALVE REPLACEMENT

This task covers:

- | | |
|---|--|
| <ul style="list-style-type: none"> a. Removal b. Installation | <ul style="list-style-type: none"> c. Follow-On Maintenance |
|---|--|

INITIAL SETUP

Equipment Conditions

- Engine shut down (TM 9-2320-366-10-1).
- Cab raised (TM 9-2320-366-10-1).

Tools and Special Tools

- Tool Kit, Genl Mech (Item 46, Appendix C)

Materials/Parts

- Packing, Preformed (Item 210, Appendix G)
- Packing, Preformed (Item 203, Appendix G)
- Packing, Preformed (Item 200, Appendix G)

WARNING

Diesel fuel is flammable. If fuel is spilled, clean it up immediately. Failure to comply may result in serious injury or death to personnel.

a. Removal.

- (1) Disconnect fuel return hose assembly (1) from 90-degree fitting (2).
- (2) Remove 90-degree fitting (2) and preformed packing (3) from adapter (4). Discard preformed packing.

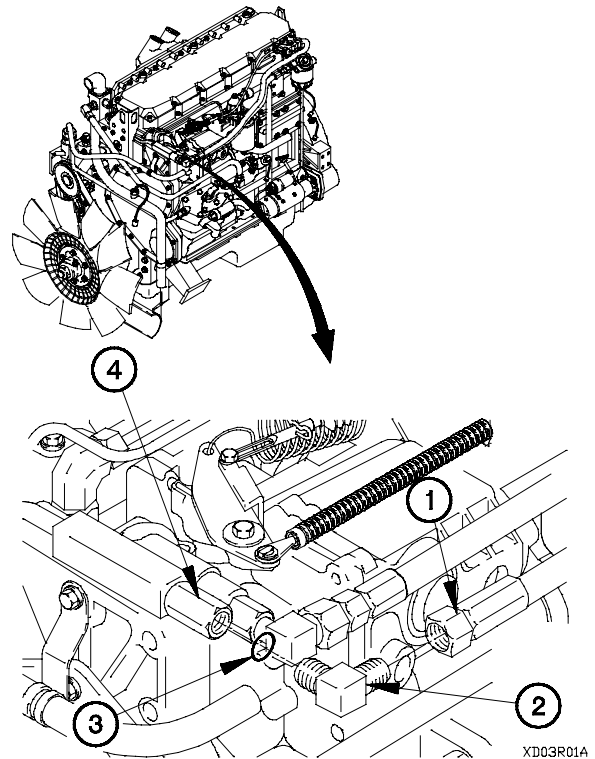

4-3. FUEL PRESSURE REGULATING VALVE REPLACEMENT (CONT)

- (3) Remove adapter (4) and preformed packing (5) from tube assembly (6). Discard preformed packing.
- (4) Remove spring (7) from tube assembly (6).
- (5) Remove fuel pressure regulating valve (8) and preformed packing (9) from tube assembly (6). Discard preformed packing.

b. Installation.

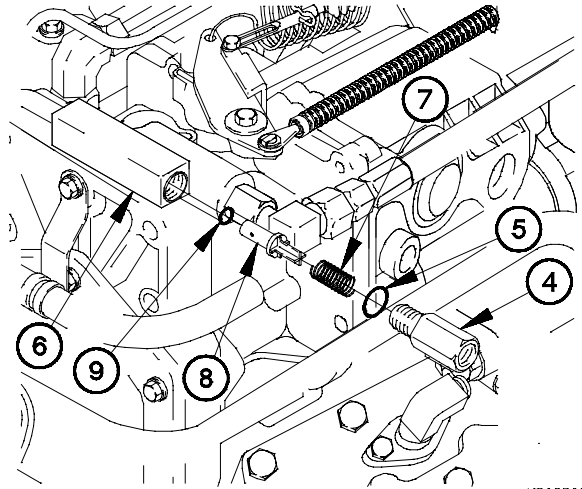

XD03R02A

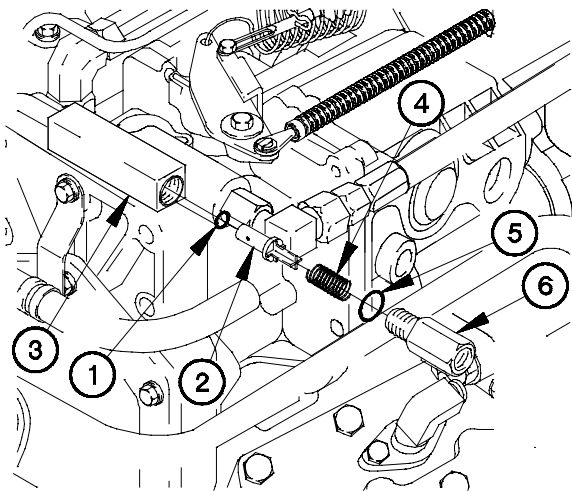

XD03I01A

- (1) Install preformed packing (1) and fuel pressure regulating valve (2) in tube assembly (3).
- (2) Install spring (4) in tube assembly (3).
- (3) Install preformed packing (5) and adapter (6) in tube assembly (3).

- (4) Install preformed packing (7) and 90-degree fitting (8) in adapter (6).
- (5) Connect fuel return hose assembly (9) to 90-degree fitting (8).

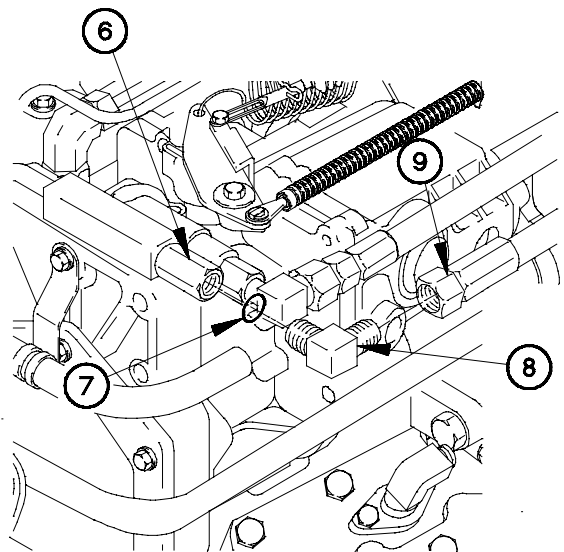

XD03I02A

c. Follow-On Maintenance.

- (1) Lower cab (TM 9-2320-366-10-1).
- (2) Start engine (TM 9-2320-366-10-1).
- (3) Raise cab (TM 9-2320-366-10-1).
- (4) Check for fuel leaks around regulating valve.
- (5) Check that engine runs smoothly at low idle speed.
- (6) Check that engine runs smoothly at high idle speed.
- (7) Lower cab (TM 9-2320-366-10-1).
- (8) Shut down engine (TM 9-2320-366-10-1).

End of Task.

4-4. TURBOCHARGER TO CHARGE AIR COOLER TUBE AND HOSES REPLACEMENT

This task covers:

- a. Removal
- b. Installation
- c. Follow-On Maintenance

INITIAL SETUP

Equipment Conditions

Engine shut down (TM 9-2320-366-10-1).
 Cab raised (TM 9-2320-366-10-1).

Materials/Parts

Cap and Plug Set (Item 14, Appendix D)

Tools and Special Tools

Tool Kit, Genl Mech (Item 46, Appendix C)
 Wrench, Torque, 0-200 lb-in. (Item 59, Appendix C)
 Socket Set, Socket Wrench (Item 36, Appendix C)

a. Removal.

NOTE

Note position of clamps prior to removal.

- (1) Loosen two hose clamps (1) and hose clamps (2) on turbocharger to charge air cooler tube (3).
- (2) Remove turbocharger to charge air cooler tube (3) from charge air cooler (4) and turbocharger (5).

CAUTION

Cap or plug turbocharger outlet and charge air cooler inlet to prevent contamination of engine intake air system. Failure to comply may result in damage to equipment.

- (3) Cap or plug turbocharger outlet (6) and charge air cooler inlet (4).

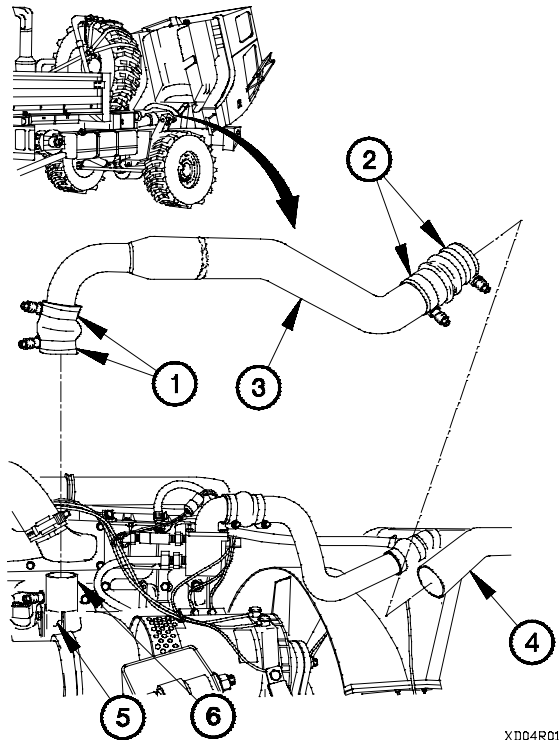

XD04R011

- (4) Remove two clamps (1) and hose (7) from turbocharger to charge air cooler tube (3).
- (5) Remove two clamps (2) and hose (8) from turbocharger to charge air cooler tube (3).

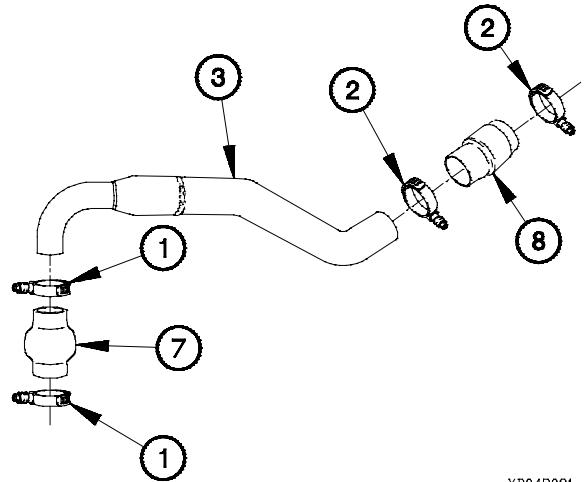

XD04R021

b. Installation.

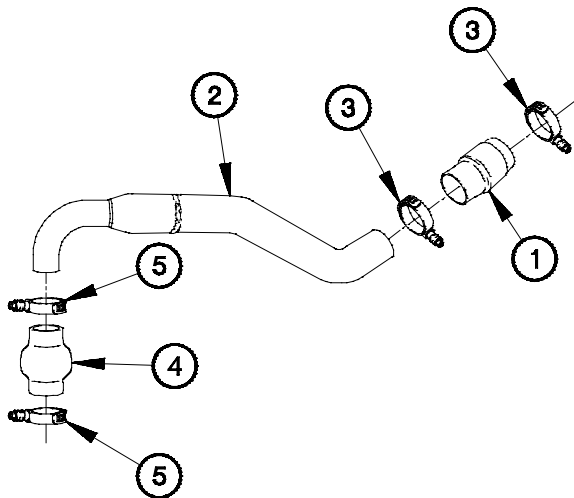

XD04I011

- (1) Position hose (1) on turbocharger to charge air cooler tube (2) with two clamps (3).
- (2) Position hose (4) on turbocharger to charge air cooler tube (2) with two clamps (5).

- (3) Remove caps or plugs from turbocharger outlet (6) and charge air cooler inlet (7).

CAUTION

Clamps at charge air cooler end of turbocharger to charge air cooler tube must be oriented as noted in removal. Failure to comply may result in damage to equipment.

- (4) Position turbocharger to charge air cooler tube (2) on charge air cooler (7) and turbocharger (8).
- (5) Tighten two hose clamps (3) and hoses clamps (5) to 90-100 lb-in. (10-11 N·m).

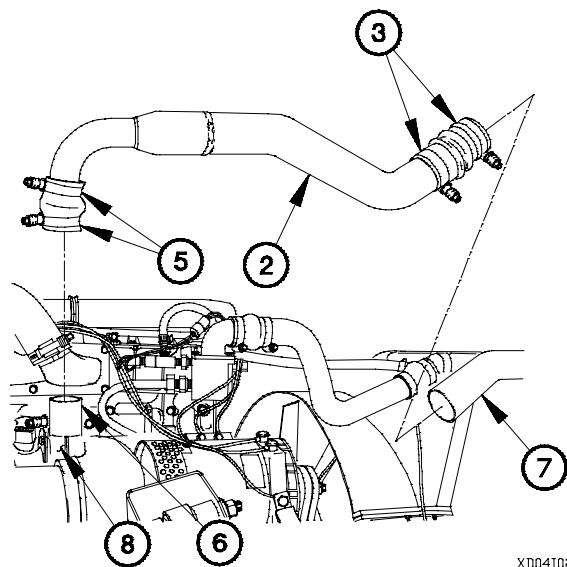

XD04I021

**4-4. TURBOCHARGER TO CHARGE AIR COOLER TUBE AND HOSES REPLACEMENT
(CONT)**

c. Follow-On Maintenance.

- (1) Lower cab (TM 9-2320-366-10-1).
- (2) Start engine (TM 9-2320-366-10-1).
- (3) Raise cab (TM 9-2320-366-10-1).
- (4) Check for air leaks around turbocharger to charge air cooler tube.
- (5) Lower cab (TM 9-2320-366-10-1).
- (6) Shut down engine (TM 9-2320-366-10-1).

End of Task.

4-5. CHARGE AIR COOLER TO AIR INLET ELBOW TUBES AND HOSES REPLACEMENT

This task covers:

- a. Removal
- b. Installation
- c. Follow-On Maintenance

INITIAL SETUP

Equipment Conditions

- Engine shut down (TM 9-2320-366-10-1).
- Cab raised (TM 9-2320-366-10-1).

Tools and Special Tools

- Tool Kit, Genl Mech (Item 46, Appendix C)
- Screwdriver Attachment, Socket Wrench (Item 61, Appendix B)

Tools and Special Tools (Cont)

- Socket Set, Socket Wrench (Item 36, Appendix C)
- Wrench, Torque, 0-200 lb-in. (Item 59, Appendix C)
- Wrench, Torque, 0-175 lb-ft (Item 58, Appendix C)

Materials/Parts

- Nut, Self-Locking (2) (Item 154, Appendix G)

a. Removal.

- (1) Remove two self-locking nuts (1), screws (2), and upper charge air tube bracket (3) from lower charge air tube bracket (4). Discard self-locking nuts.

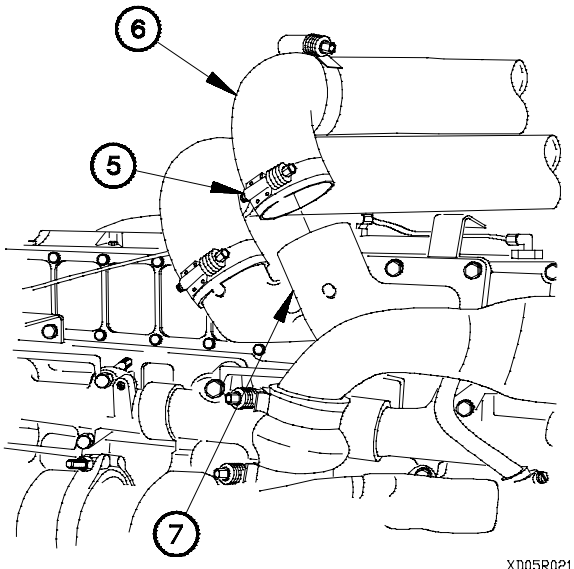
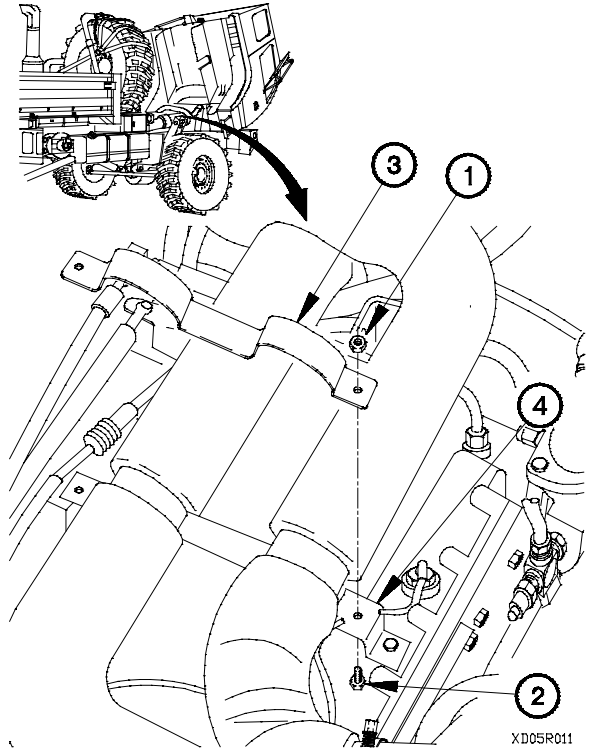

NOTE

Inner and outer charge air cooler to air inlet elbow tubes are removed the same way. Outer charge air cooler to air inlet elbow tube shown.

- (2) Loosen clamp (5) on hose (6).
- (3) Disconnect hose (6) from air inlet elbow (7).

4-5. CHARGE AIR COOLER TO AIR INLET ELBOW TUBES AND HOSES REPLACEMENT (CONT)

NOTE

Note position of clamps prior to removal.

- (4) Loosen three clamps (8) on hose (9).
- (5) Remove charge air cooler to air inlet elbow tube (10) from hose (9).
- (6) Remove hose (9) from charge air cooler (11).

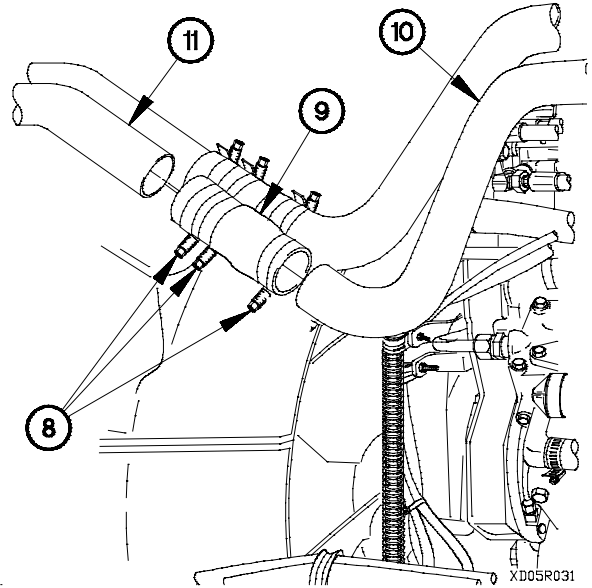

NOTE

Vehicle serial numbers 0001 through 3091 were originally equipped with a lower charge air tube bracket (part number 12421172). Vehicle serial numbers 3092 and higher were originally equipped with a lower charge air tube bracket (part number 12421172-001). Perform steps (7) and (8) on vehicle serial numbers 0001 through 3091 that have not previously had a valve cover or lower charge air tube bracket replaced.

- (7) Remove screw (12) and washer (13) from lower charge air tube bracket (4).
- (8) Remove screw (14), washer (15), and lower charge air tube bracket (4) from duct manifold (16).

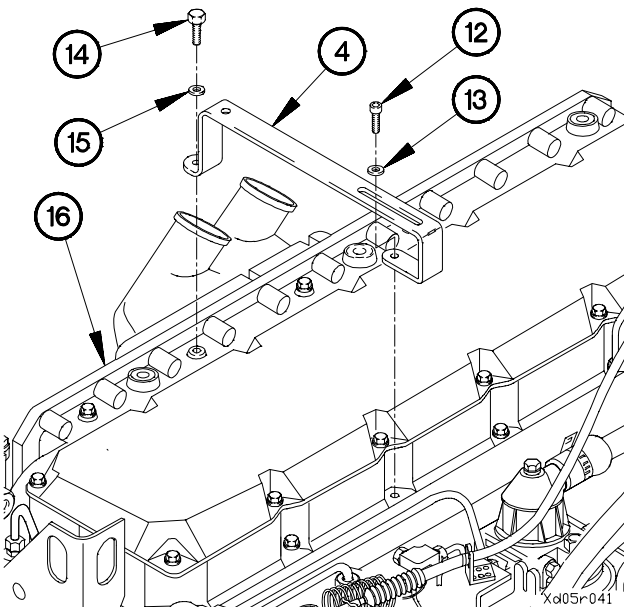

NOTE

Perform steps (9) through (11) on vehicle serial numbers 3091 and higher, and vehicle serial numbers 0001 through 3091 that have previously had a valve cover or lower charge air tube bracket replaced.

- (9) Remove screw (12) and washer (13) from lower charge air tube bracket (17).
- (10) Remove screw (18), washer (19), and clamp (20) from lower charge air tube bracket (17).
- (11) Remove screw (21), washer (22) and lower charge air tube bracket (17) from air inlet elbow (23).

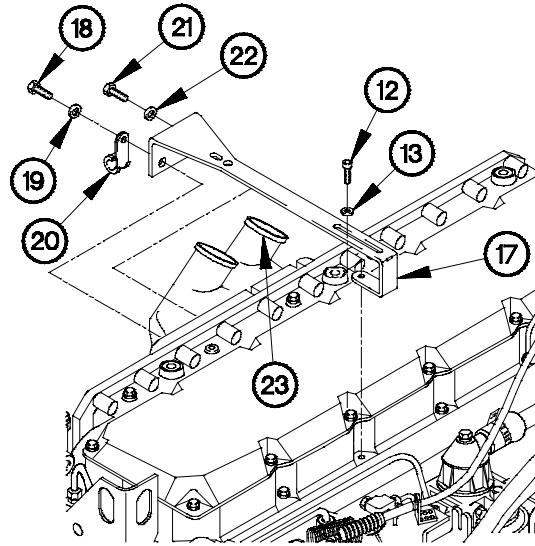

XD05R051

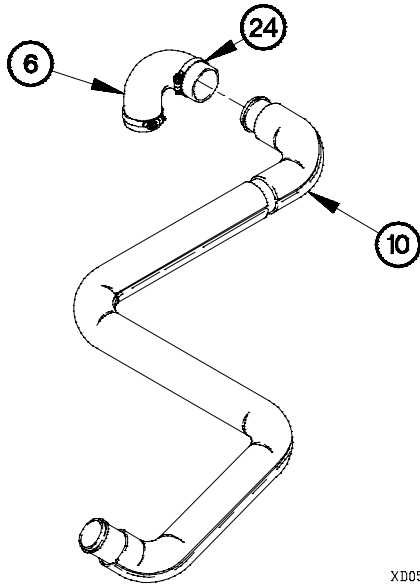

XD05R061

- (12) Loosen clamp (24) on hose (6).
- (13) Remove hose (6) from charge air cooler to air inlet elbow tube (10).

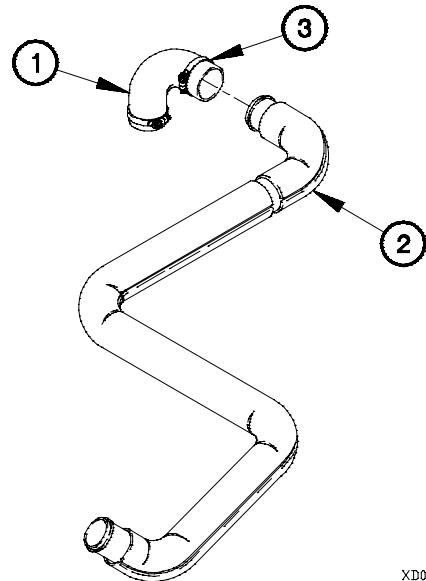

XD05I011

b. Installation.

- (1) Position hose (1) on charge air cooler to air inlet elbow tube (2) with clamp (3).

4-5. CHARGE AIR COOLER TO AIR INLET ELBOW TUBES AND HOSES REPLACEMENT (CONT)

NOTE

Perform steps (2) through (5) on vehicle serial numbers 3091 and higher, and vehicle serial numbers 0001 through 3091 that have previously had a valve cover or lower charge air tube bracket replaced.

- (2) Position lower charge air tube bracket (4) on air inlet elbow (5) with washer (6) and screw (7).
- (3) Position clamp (8), washer (9), and screw (10) in lower charge air tube bracket (4).
- (4) Position washer (11) and screw (12) in lower charge air tube bracket (4).
- (5) Tighten screw (7), screw (10), and screw (12) to 15-25 lb-ft (20-34 N·m).

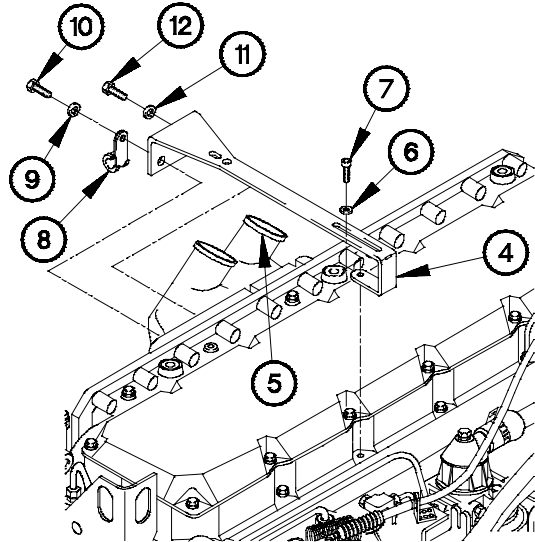

XD051021

NOTE

Perform steps (6) through (8) on vehicle serial numbers 0001 through 3091 that have not previously had a valve cover or lower charge air tube bracket replaced.

- (6) Position lower charge air tube bracket (13) on duct manifold (14) with washer (15) and screw (16).
- (7) Position washer (17) and screw (18) in lower charge air tube bracket (13).
- (8) Tighten screws (16 and 18) to 15-25 lb-ft (20-34 N·m).

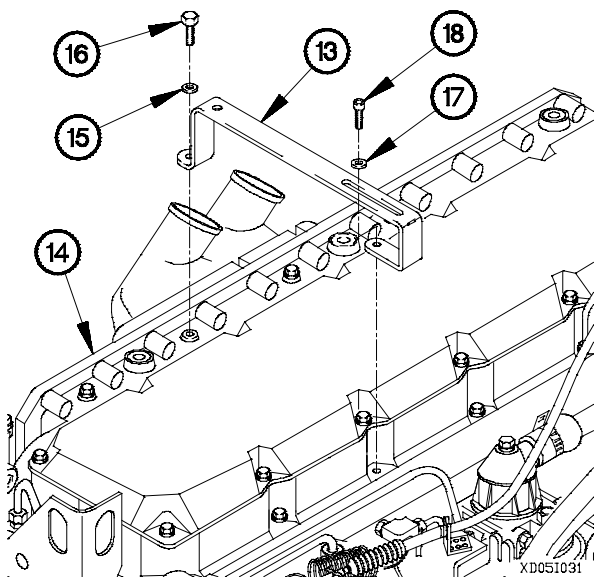

XD051031

NOTE

Inner and outer charge air cooler to air inlet elbow tubes are installed the same way. Outer charge air cooler to air inlet elbow tube shown.

- (9) Position hose (19) on charge air cooler (20) with three clamps (21).
- (10) Position charge air cooler to air inlet elbow tube (2) in hose (19).

CAUTION

Clamps at charge air cooler end of charge air cooler to air inlet elbow tube must be oriented with screw vertical. Failure to comply will cause interference with bottom of cab.

- (11) Tighten three clamps (21) to 90-100 lb-in. (7-8 N·m).

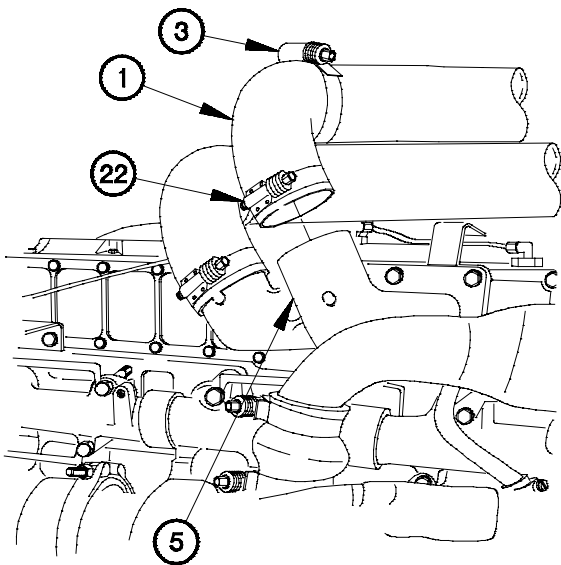
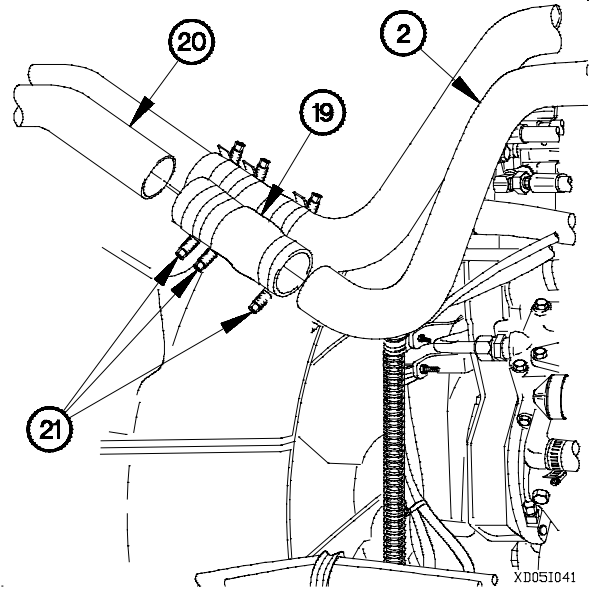

CAUTION

All clamps on engine air intake path must be positioned and tightened correctly. Failure to comply may allow foreign matter into engine air intake and result in engine failure.

- (12) Position hose (1) on air inlet elbow (5) with clamp (22).
- (13) Tighten clamps (3 and 22) to 90-100 lb-in. (7-18 N·m).

4-5. CHARGE AIR COOLER TO AIR INLET ELBOW TUBES AND HOSES REPLACEMENT (CONT)

- (14) Position upper charge air tube bracket (23) on lower charge air tube bracket (4) with two screws (24) and self-locking nuts (25).
- (15) Tighten two self-locking nuts (25) to 20-26 lb-ft (27-35 N·m).

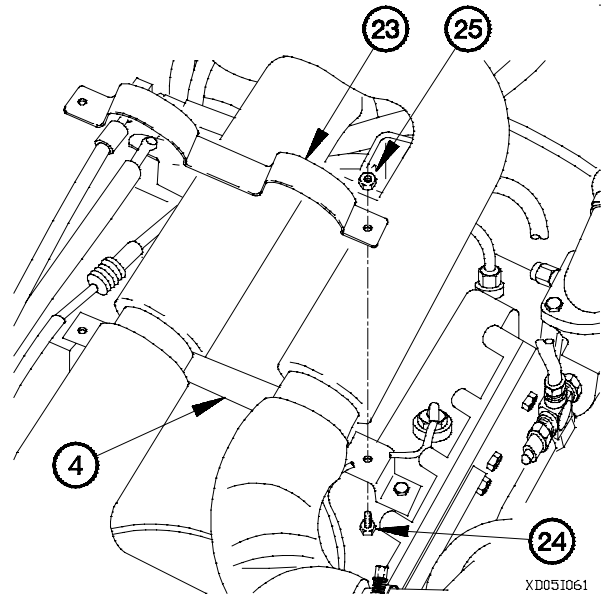

c. Follow-On Maintenance.

- (1) Lower cab (TM 9-2320-366-10-1).
- (2) Start engine (TM 9-2320-366-10-1).
- (3) Raise cab (TM 9-2320-366-10-1).
- (4) Check around charge air cooler to air inlet elbow tubes and hoses for air leaks.
- (5) Lower cab (TM 9-2320-366-10-1).
- (6) Shut down engine (TM 9-2320-366-10-1).

End of Task.

4-6. FUEL RATIO CONTROL TUBE REPLACEMENT

This task covers:

- a. Removal
- b. Installation
- c. Follow-On Maintenance

INITIAL SETUP

Equipment Conditions

- Engine shut down (TM 9-2320-366-10-1).
- Cab raised (TM 9-2320-366-10-1).

Materials/Parts

- Packing, Preformed (2) (Item 206, Appendix G)
- Packing, Preformed (2) (Item 204, Appendix G)

Tools and Special Tools

- Tool Kit, Genl Mech (Item 46, Appendix C)
- Wrench, Torque, 0-175 lb-ft (Item 58, Appendix C)

WARNING

Diesel fuel is flammable. If fuel is spilled, clean it up immediately. Failure to comply may result in serious injury or death to personnel.

a. Removal.

- (1) Remove screw (1), washer (2), and loop clamp (3) from pressure regulating orifice (4).
- (2) Disconnect fuel ratio control tube (5) from adapter (6).
- (3) Remove preformed packing (7) from adapter (6). Discard preformed packing.
- (4) Remove adapter (6) from inlet manifold (8).
- (5) Remove preformed packing (9) from adapter (6). Discard preformed packing.

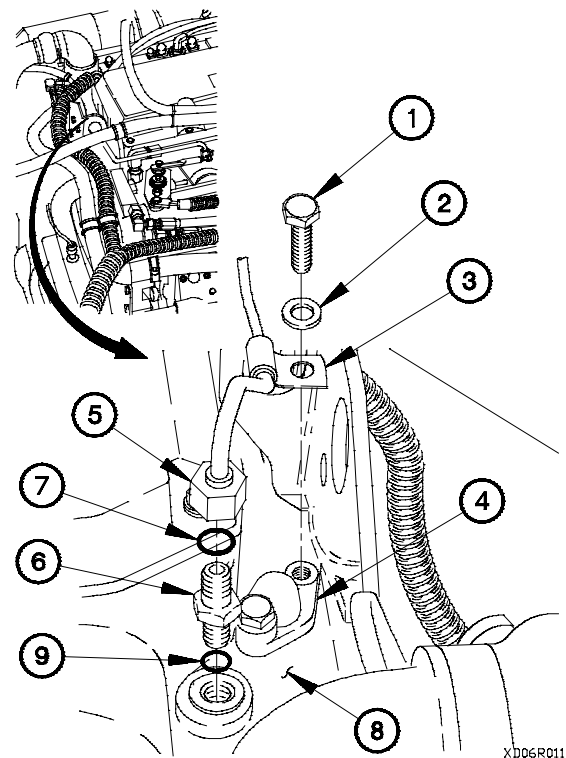

4-6. FUEL RATIO CONTROL TUBE REPLACEMENT (CONT)

- (6) Remove fuel ratio control tube (5) from adapter (10).
- (7) Remove preformed packing (11) from adapter (10). Discard preformed packing.
- (8) Remove adapter (10) from fuel governor (12).
- (9) Remove preformed packing (13) from adapter (10). Discard preformed packing.

b. Installation.

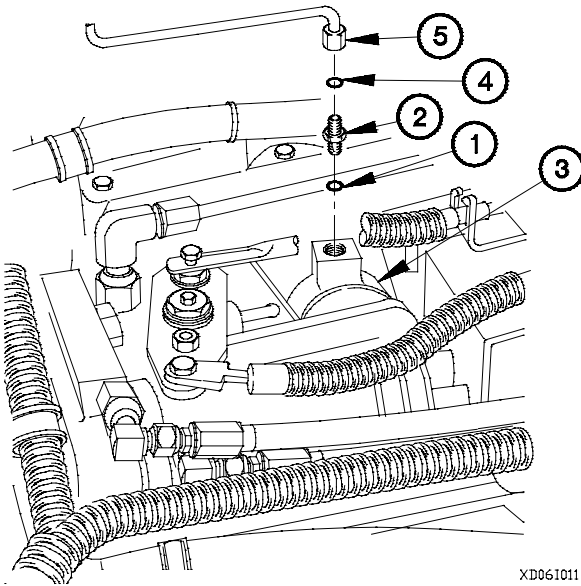

- (1) Install preformed packing (1) on adapter (2).
- (2) Install adapter (2) in fuel governor (3).
- (3) Install preformed packing (4) in adapter (2).
- (4) Connect fuel ratio control tube (5) to adapter (2).

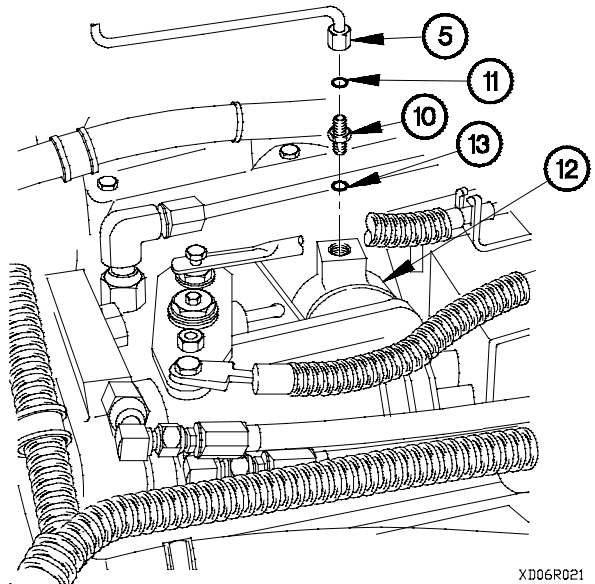

XD06R021

- (5) Install preformed packing (6) on adapter (7).
- (6) Install adapter (7) in inlet manifold (8).
- (7) Install preformed packing (9) on adapter (7).
- (8) Install fuel ratio control tube (5) on adapter (7).
- (9) Position loop clamp (10), washer (11), and screw (12) in pressure regulating orifice (13).
- (10) Tighten screw (12) to 15-25 lb-ft (20-34 N·m).

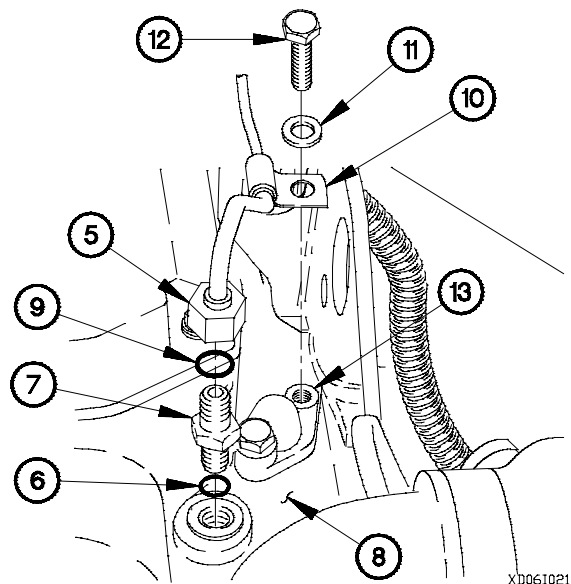

XD06I021

c. Follow-On Maintenance.

- (1) Lower cab (TM 9-2320-366-10-1).
- (2) Start engine (TM 9-2320-366-10-1).
- (3) Raise cab (TM 9-2320-366-10-1).
- (4) Check for fuel leaks around fuel ratio control tube.
- (5) Check that engine runs smoothly at low idle speed.
- (6) Check that engine runs smoothly at high idle speed.
- (7) Lower cab (TM 9-2320-366-10-1).
- (8) Shut down engine (TM 9-2320-366-10-1).

End of Task.

4-7. ORIFICE TUBE ASSEMBLY REPLACEMENT	
This task covers:	
a. Removal b. Installation	c. Follow-On Maintenance
INITIAL SETUP	
Equipment Conditions Engine shut down (TM 9-2320-366-10-1). Cab raised (TM 9-2320-366-10-1). Fuel pressure regulating valve removed (para 4-3). Fuel ratio control tube removed (para 4-6).	Tools and Special Tools Tool Kit, Genl Mech (Item 46, Appendix C) Wrench, Torque, 0-175 lb-ft (Item 58, Appendix C)
	Materials/Parts Packing, Preformed (Item 209, Appendix G)

WARNING

Diesel fuel is flammable. If fuel is spilled, clean it up immediately. Failure to comply may result in serious injury or death to personnel.

a. Removal.

- (1) Remove two screws (1) and washers (2) from orifice tube assembly (3).
- (2) Remove screw (4), orifice tube assembly (3), and preformed packing (5) from cylinder head (6). Discard preformed packing.

b. Installation.

- (1) Position preformed packing (5) on cylinder head (6).
- (2) Position orifice tube assembly (3) on cylinder head (6) with screw (4).
- (3) Position two washers (2) and screws (1) in orifice tube assembly (3).
- (4) Tighten screw (4) to 15-25 lb-ft (20-34 N-m).
- (5) Tighten two screws (1) to 33-47 lb-ft (45-64 N-m).

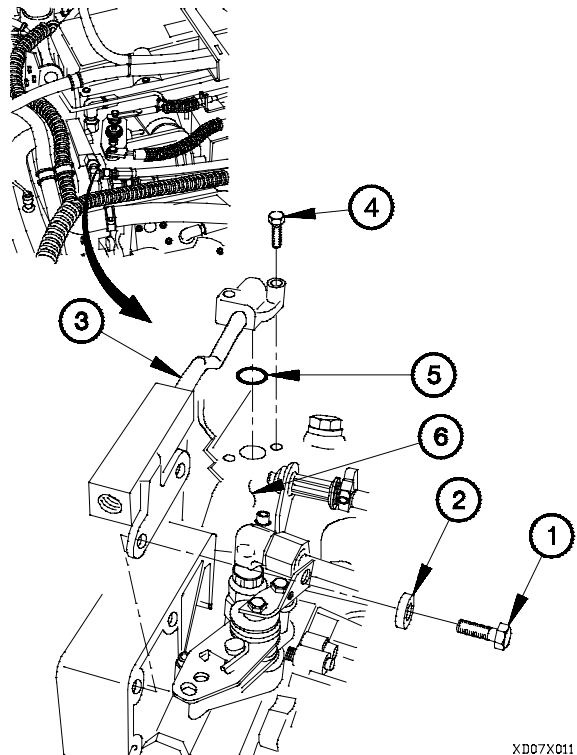

XD07X011

c. Follow-On Maintenance.

- (1) Install fuel ratio control tube (para 4-6).
- (2) Install fuel pressure regulating valve (para 4-3).
- (3) Lower cab (TM 9-2320-366-10-1).
- (4) Start engine (TM 9-2320-366-10-1).
- (5) Raise cab (TM 9-2320-366-10-1).
- (6) Check for fuel leaks around fuel ratio control tube and orifice tube assembly.
- (7) Check that engine runs smoothly at low idle speed.
- (8) Check that engine runs smoothly at high idle speed.
- (9) Lower cab (TM 9-2320-366-10-1).
- (10) Shut down engine (TM 9-2320-366-10-1).

End of Task.

4-8. FUEL TANK AND BRACKETS REPLACEMENT

This task covers:

- a. Removal
- b. Installation
- c. Follow-On Maintenance

INITIAL SETUP

Equipment Conditions

Batteries disconnected (para 7-57).

Tools and Special Tools

- Tool Kit, Genl Mech (Item 46, Appendix C)
- Container (60 Gal (227 L) capacity)
- Wrench, Torque, 0-175 lb-ft (Item 58, Appendix C)
- Wrench, Torque, 0-600 lb-ft (Item 60, Appendix C)
- Socket Set, Impact (Item 33, Appendix C)
- Wrench, Torque, 0-200 lb-in. (Item 59, Appendix C)

Materials/Parts

- Rag, Wiping (Item 50, Appendix D)
- Dispenser, Pressure Sensitive Adhesive Tape (Item 20, Appendix D)
- Ties, Cable, Plastic (Item 69, Appendix D)
- Sealing Compound (Item 56, Appendix D)
- Primer, Sealing Compound (Item 49, Appendix D)
- Packing, Preformed (Item 216, Appendix G)
- Nut, Self-Locking (2) (Item 156, Appendix G)
- Nut, Self-Locking (8) (Item 161, Appendix G)

Personnel Required

(2)

WARNING

Diesel fuel is flammable. If fuel is spilled, clean it up immediately. Failure to comply may result in serious injury or death to personnel.

a. Removal.

NOTE

Remove plastic cable ties as required.

- (1) Disconnect connector clamp (1) from fuel level sending unit connector (2).
- (2) Disconnect fuel level sending unit connector (2) from connector P82 (3).
- (3) Position container under fuel tank (4).
- (4) Remove drain plug (5) from fuel tank (4) and drain fuel.

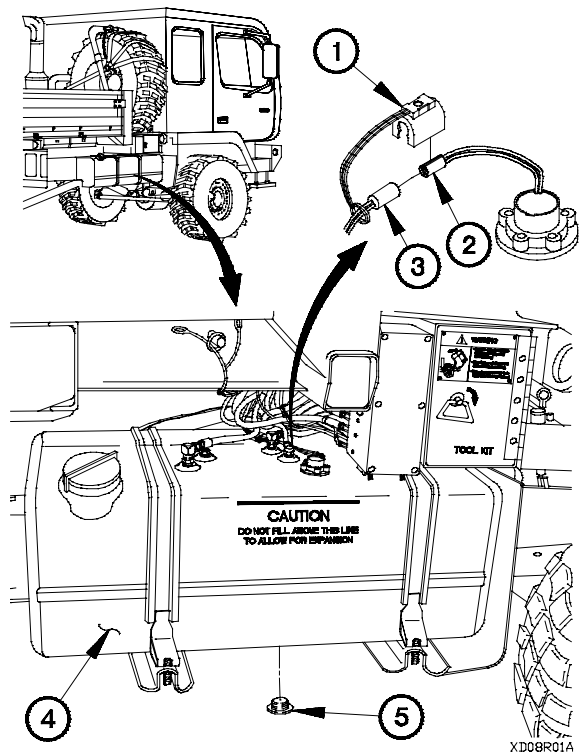

NOTE

Tag fuel hoses and connection points prior to disconnecting.

- (5) Disconnect fuel hose (6) from 90-degree pickup tube fitting (7).
- (6) Disconnect fuel hose (8) from 90-degree return fitting (9).
- (7) Disconnect fuel hose (10) from relief valve (11).

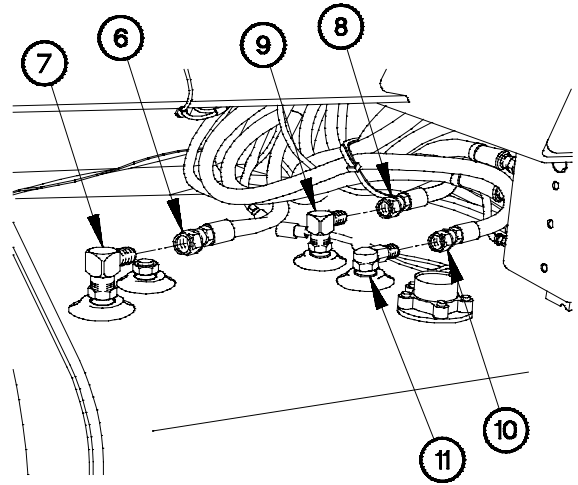

XD08R02-

- (8) Remove four nuts (12) from two straps (13).
- (9) Move two straps (13) away from fuel tank (4).

NOTE

Step (10) requires the aid of an assistant.

- (10) Remove fuel tank (4) from support brackets (14 and 15).

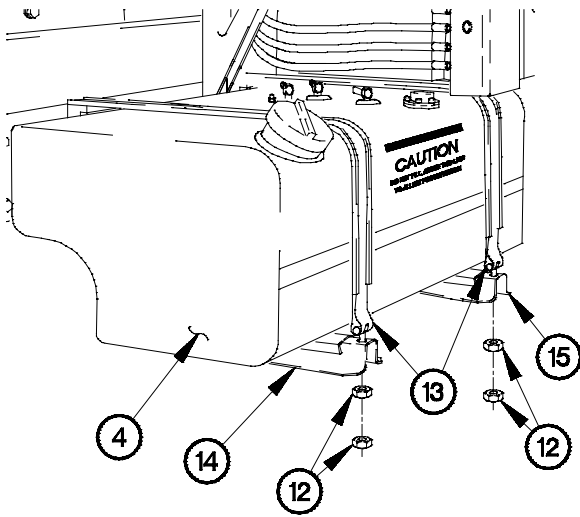

XD08R03A

- (11) Remove relief valve (11) from fuel tank (4).
- (12) Remove 90-degree pickup tube fitting (7) from fuel tank (4).
- (13) Remove 90-degree return fitting (9) from fuel tank (4).
- (14) Remove five screws (16), fuel level sending unit (17), and preformed packing (18) from fuel tank (4). Discard preformed packing.
- (15) Deleted.

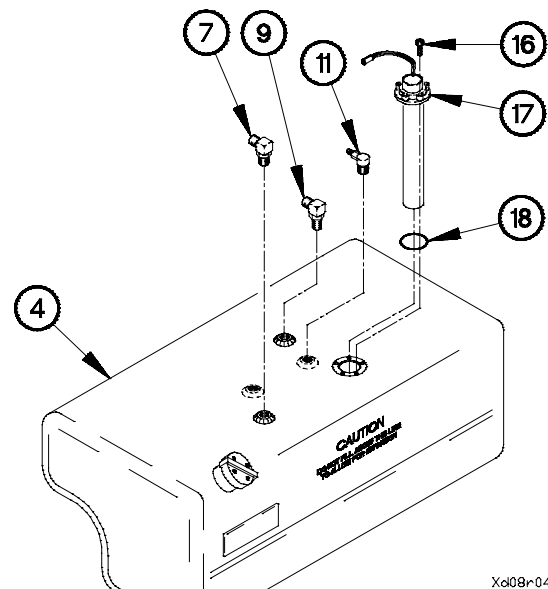

Xa08r04a

4-8. FUEL TANK AND BRACKETS REPLACEMENT (CONT)

- (16) Remove fuel tank insulators (20 and 21) from support brackets (14 and 15).
- (17) Remove two bolts (22) and straps (13) from support brackets (14 and 15).
- (18) Remove two insulator straps (23) from straps (13).

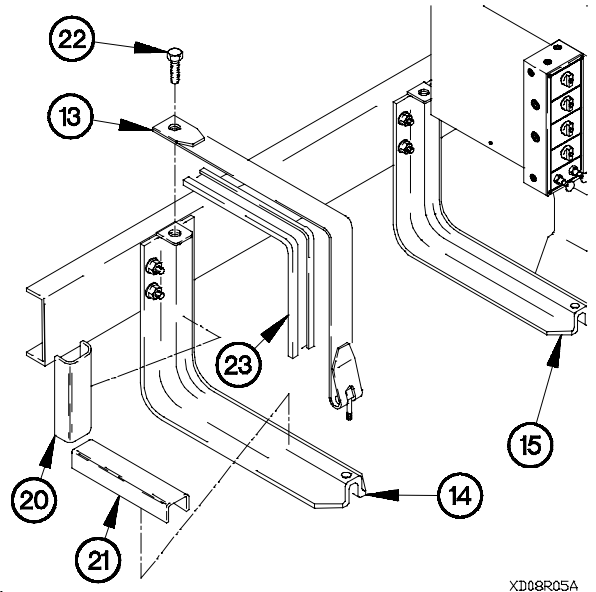

XD08R05A

- (19) Remove four self-locking nuts (24), bolts (25), two plates (26), and support bracket (14) from frame rail (27). Discard self-locking nuts.

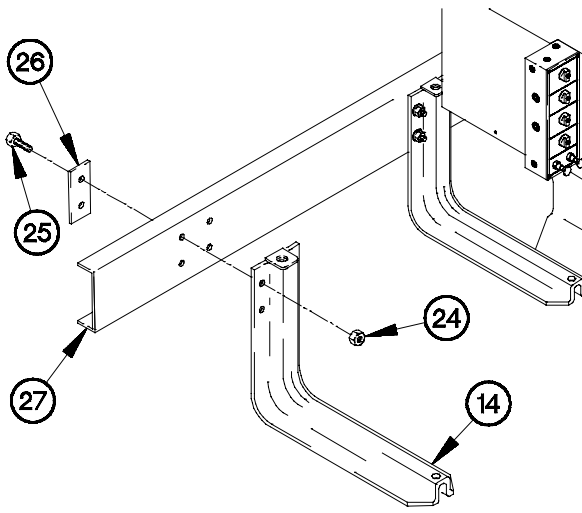

XD08R06A

- (20) Remove two self-locking nuts (28), washers (29), and screws (30) from support bracket (15). Discard self-locking nuts.
- (21) Remove self-locking nut (31) and bolt (32) from support bracket (15). Discard self-locking nut.

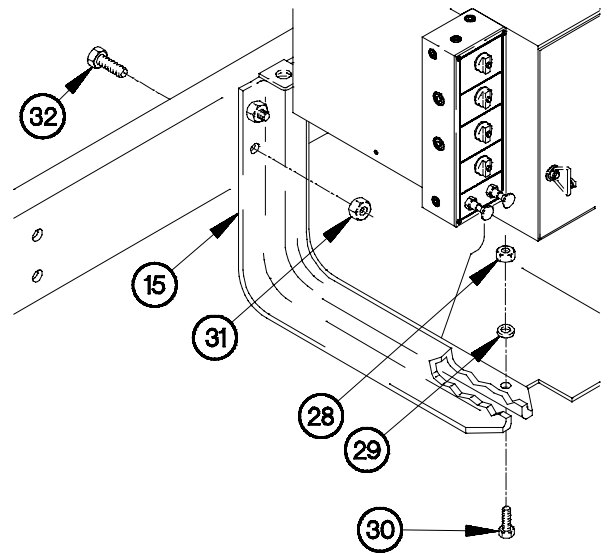

XD08R07A

- (22) Remove self-locking nut (33) and bolt (34) from support bracket (15). Discard self-locking nut.
- (23) Remove two self-locking nuts (35), bolts (36), plate (37), and support bracket (15) from frame rail (27). Discard self-locking nuts.

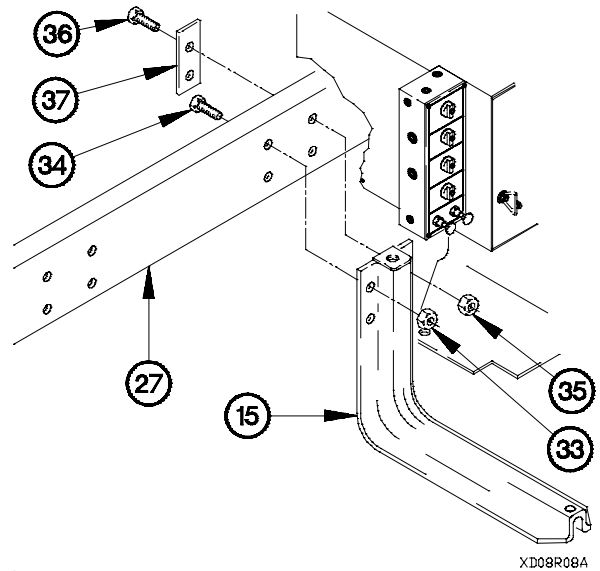

b. Installation.

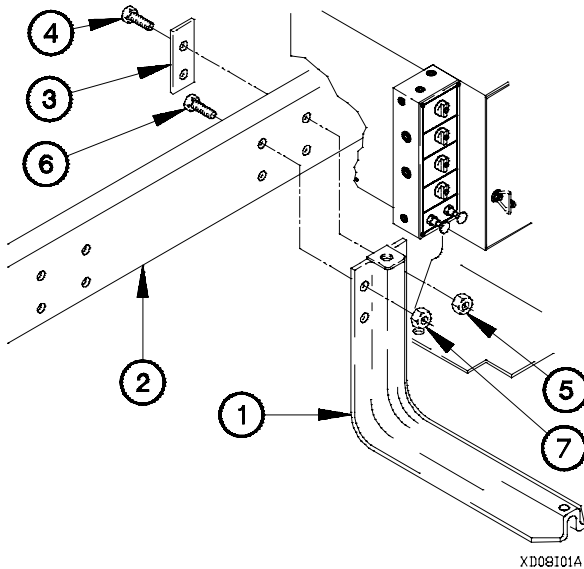

- (1) Position support bracket (1) on frame rail (2) with plate (3), two bolts (4), and self-locking nuts (5).
- (2) Position bolt (6) and self-locking nut (7) in support bracket (1).

- (3) Position bolt (8) and self-locking nut (9) in support bracket (1).

NOTE

Step (4) requires the aid of an assistant.

- (4) Tighten two self-locking nuts (5), and self-locking nuts (7 and 9) to 197-237 lb-ft (267-321 N-m).
- (5) Position two screws (10), washers (11), and self-locking nuts (12) in support bracket (1).
- (6) Tighten two self-locking nuts (12) to 42-52 lb-ft (57-70 N-m).

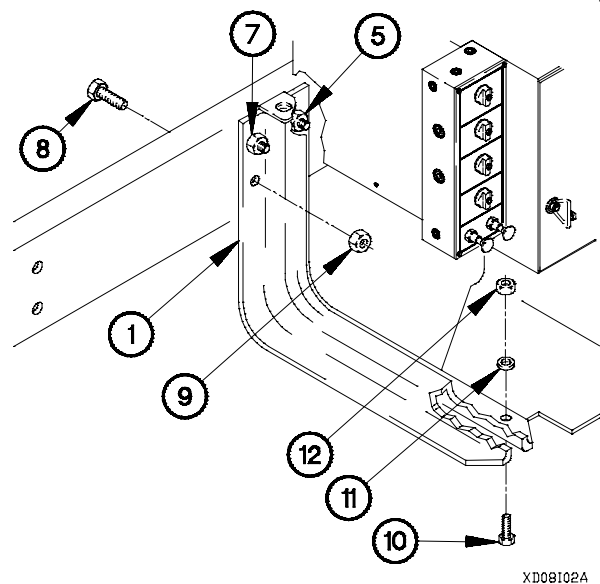

4-8. FUEL TANK AND BRACKETS REPLACEMENT (CONT)

- (7) Position support bracket (13) on frame rail (2) with two plates (14), four bolts (15), and self-locking nuts (16).

NOTE

Step (8) requires the aid of an assistant.

- (8) Tighten four self-locking nuts (16) to 197-237 lb-ft (267-321 N·m).

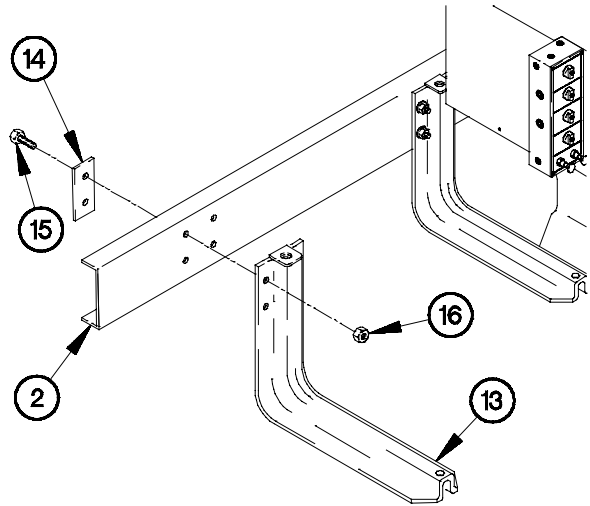

XD08I03A

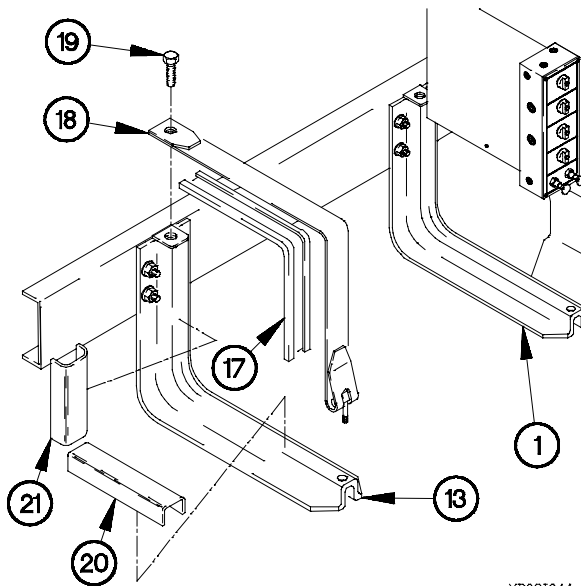

XD08I04A

- (9) Install two insulator straps (17) on straps (18).
- (10) Position two straps (18) on support brackets (1 and 13) with bolts (19).
- (11) Tighten two bolts (19) to 76-94 lb-ft (103-127 N·m).
- (12) Install fuel tank insulators (20 and 21) on support brackets (1 and 13).

- (13) Deleted.
- (14) Deleted.
- (15) Deleted.
- (16) Deleted.
- (17) Position preformed packing (25) and fuel level sending unit (26) in fuel tank (23) with five screws (27).
- (17.1) Tighten five screws (27) to 20-24 lb-in. (2-3 N-m).

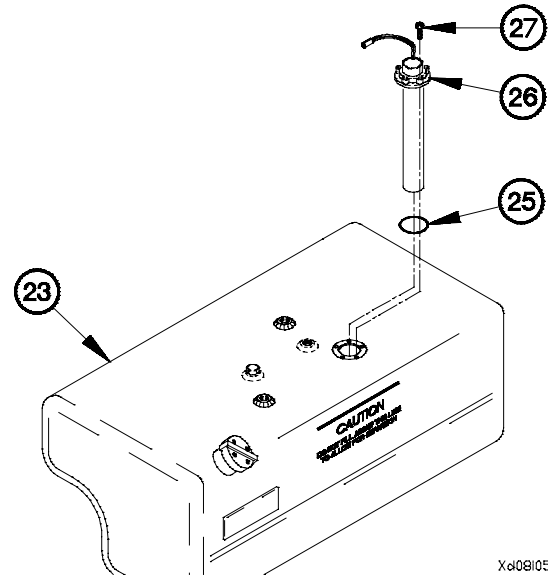

X008105a

WARNING

Adhesives, solvents, and sealing compounds can burn easily, can give off harmful vapors, and are harmful to skin and clothing. Keep away from open fire and use in a well-ventilated area. If adhesive, solvent, or sealing compound gets on skin or clothing, wash immediately with soap and water. Failure to comply may result in injury to personnel.

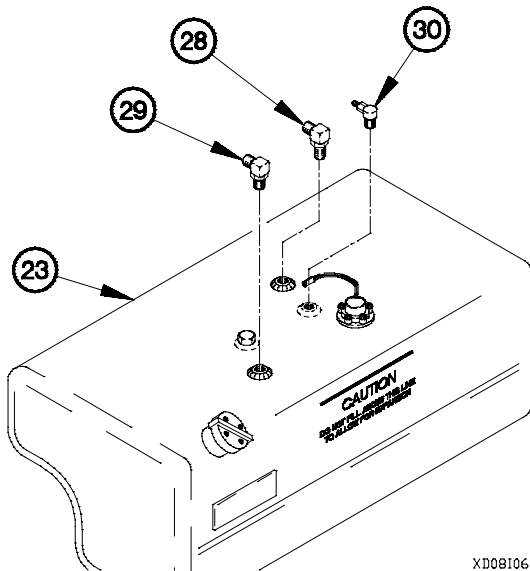

XD08106A

- (18) Apply sealing compound primer to threads of 90-degree return fitting (28), 90-degree pickup tube fitting (29), and relief valve (30).
- (19) Apply sealing compound to threads of 90-degree return fitting (28), 90-degree pickup tube fitting (29), and relief valve (30).
- (20) Install 90-degree return fitting (28) in fuel tank (23).
- (21) Install 90-degree pickup tube fitting (29) in fuel tank (23).
- (22) Install relief valve (30) in fuel tank (23).

4-8. FUEL TANK AND BRACKETS REPLACEMENT (CONT)

NOTE

Step (23) requires the aid of an assistant.

- (23) Install fuel tank (23) on support brackets (1 and 13) with straps (18).
- (24) Position two nuts (31) on two straps (18).
- (25) Tighten two nuts (31) to 76-94 lb-ft (103-127 N-m).
- (26) Install two nuts (32) on two straps (18).

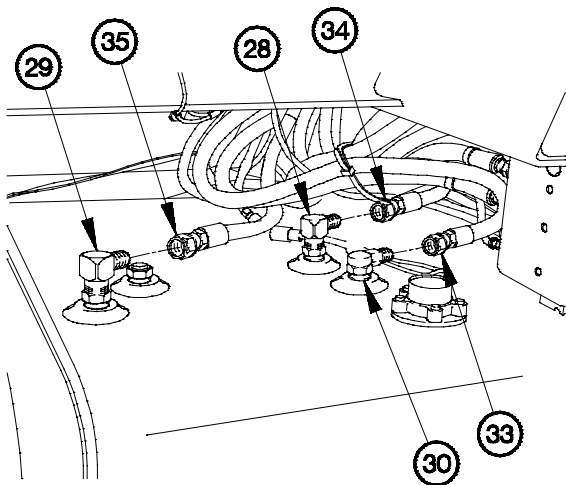
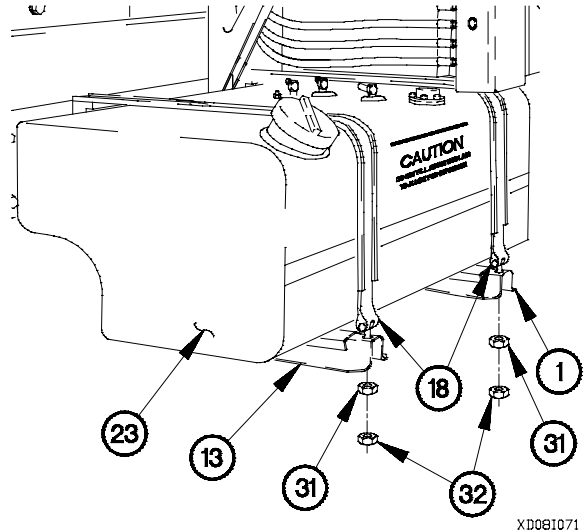

NOTE

Install plastic cable ties as required.

- (27) Connect fuel hose (33) to relief valve (30).
- (28) Connect fuel hose (34) to 90-degree return fitting (28).
- (29) Connect fuel hose (35) to 90-degree pickup tube fitting (29).

- (30) Install drain plug (36) in fuel tank (23).
- (31) Connect fuel level sending unit connector (37) to connector P82 (38).
- (32) Connect connector clamp (39) to fuel level sending unit connector (37).

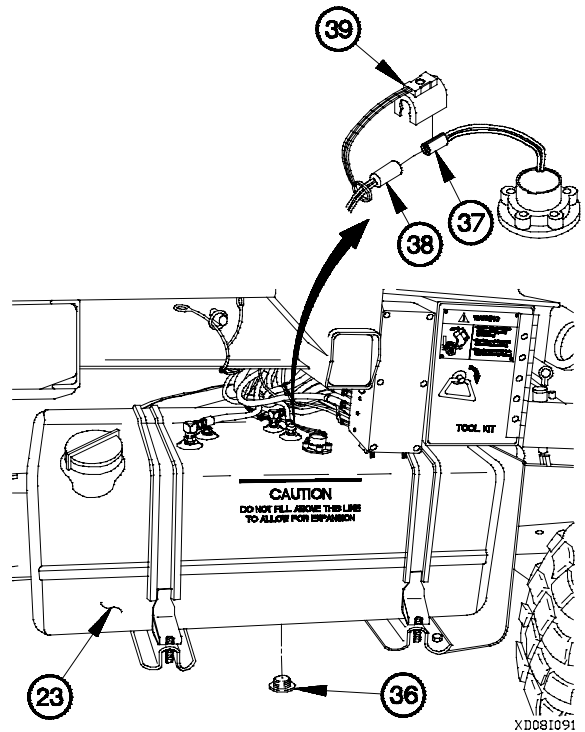

c. Follow-On Maintenance.

- (1) Fill fuel tank (TM 9-2320-366-10-1).
- (2) Bleed fuel system (para 4-11).
- (3) Check for fuel leaks around hoses and fittings.
- (4) Connect batteries (para 7-57).
- (5) Start engine (TM 9-2320-366-10-1).
- (6) Check for fuel leaks around hoses and fittings.
- (7) Shut down engine (TM 9-2320-366-10-1).

End of Task.

4-9. FUEL HOSES REPLACEMENT

This task covers:

- a. Fuel Supply Hose Removal
- b. Fuel Supply Hose Installation
- c. Fuel Transfer Hose Removal
- d. Fuel Transfer Hose Installation
- e. Fuel Return Hose Removal
- f. Fuel Return Hose Installation
- g. Fuel Tank Vent Hose Removal
- h. Fuel Tank Vent Hose Installation
- i. Follow-On Maintenance

INITIAL SETUP

Equipment Conditions

- Batteries disconnected (para 7-57).
- Cab raised (TM 9-2320-366-10-1).
- Spare tire lowered (TM 9-2320-366-10-2).

Tools and Special Tools

- Tool Kit, Genl Mech (Item 46, Appendix C)
- Pan, Drain (Item 24, Appendix C)
- Wrench, Torque, 0-200 lb-in. (Item 59, Appendix C)
- Socket Set, Socket Wrench (Item 34, Appendix C)

Tools and Special Tools (Cont)

- Wrench, Torque, 0-175 lb-ft (Item 58, Appendix C)

Materials/Parts

- Ties, Cable, Plastic (Item 69, Appendix D)
- Nut, Self-Locking (Item 150, Appendix G)
- Nut, Self-Locking (Item 156, Appendix G)

WARNING

Diesel fuel is flammable. If fuel is spilled, clean it up immediately. Failure to comply may result in serious injury or death to personnel.

a. Fuel Supply Hose Removal.

- (1) Disconnect fuel supply hose assembly (1) from 90-degree fitting (2).

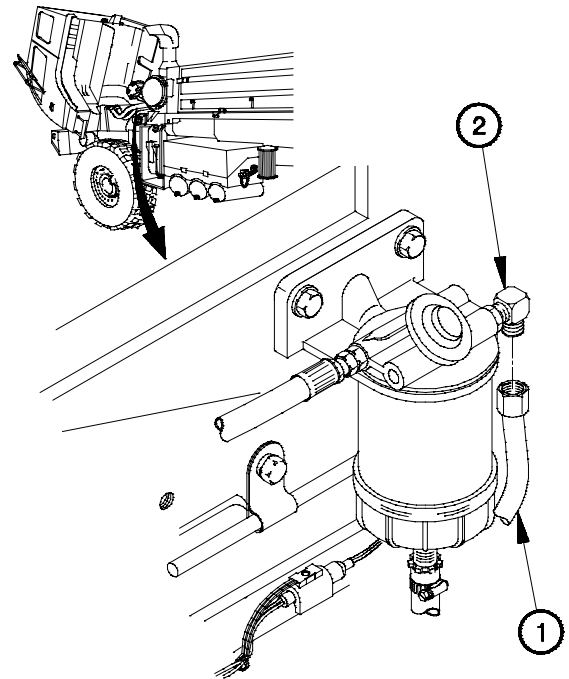

XD09A011

NOTE

- Remove plastic cable ties as required.
- Perform steps (2) and (3) on vehicle serial number 3092 and higher, and vehicle serial numbers 0001 through 3091 that have previously had a spare tire retainer or fuel hose replaced.

- (2) Remove self-locking nut (3), screw (4), and clamp (5) from spare tire retainer (6). Discard self-locking nut.
- (3) Remove fuel supply hose assembly (1) from clamp (5).

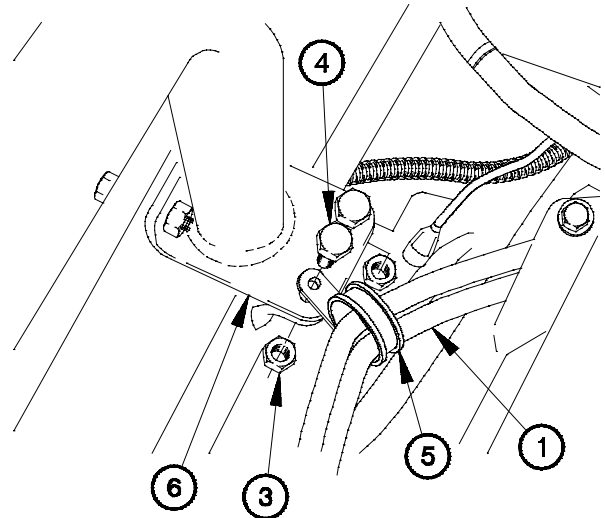

XD09A021

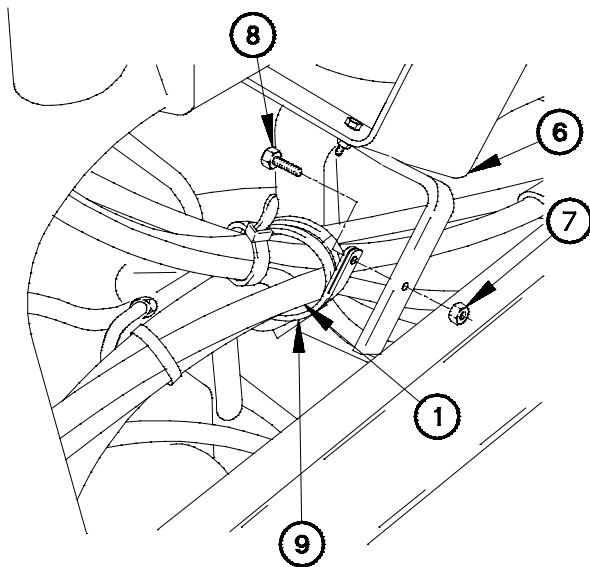

XD09A031

- (6) Remove fuel supply hose assembly (1) from 90-degree fuel pickup tube fitting (10).

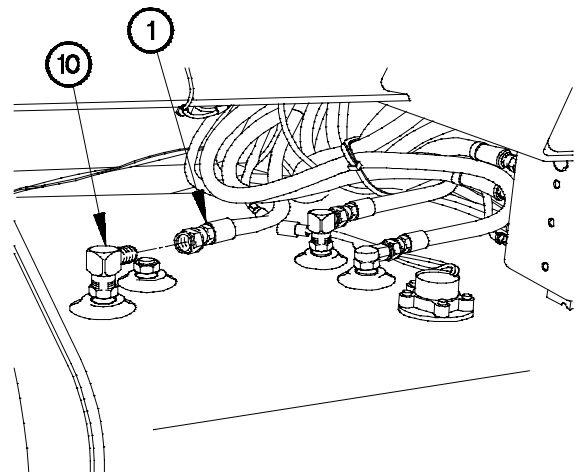

XD09A041

4-9. FUEL HOSES REPLACEMENT (CONT)

b. Fuel Supply Hose Installation.

(1) Install fuel supply hose assembly (1) on 90-degree fuel pickup tube fitting (2).

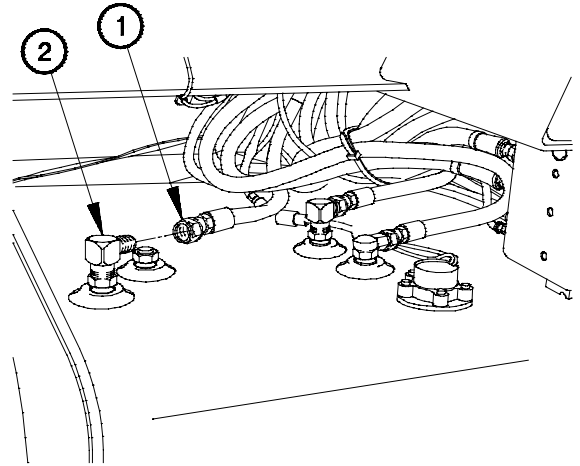

XD09B011

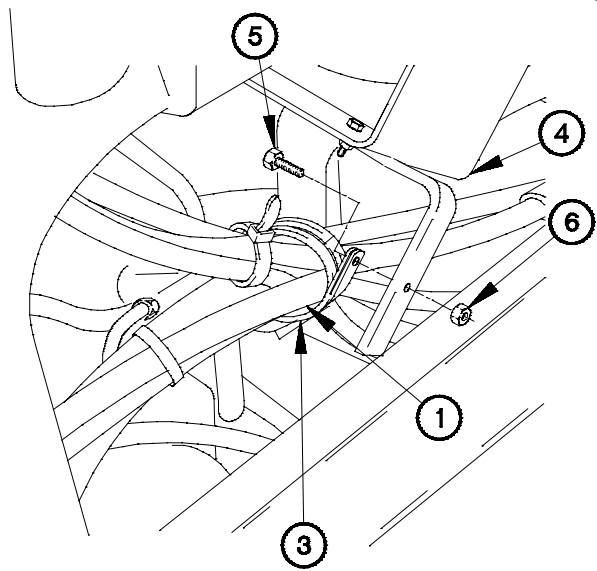

XD09B021

- (2) Install fuel supply hose assembly (1) in clamp (3).
- (3) Position clamp (3) on spare tire retainer (4) with screw (5) and self-locking nut (6).
- (4) Tighten self-locking nut (6) to 87-107 lb-in. (10-12 N·m).

- (5) Install fuel supply hose assembly (1) in clamp (7).
- (6) Position clamp (7) on spare tire retainer (4) with screw (8) and self-locking nut (9).
- (7) Tighten self-locking nut (9) to 43-52 lb-ft (58-71 N·m).

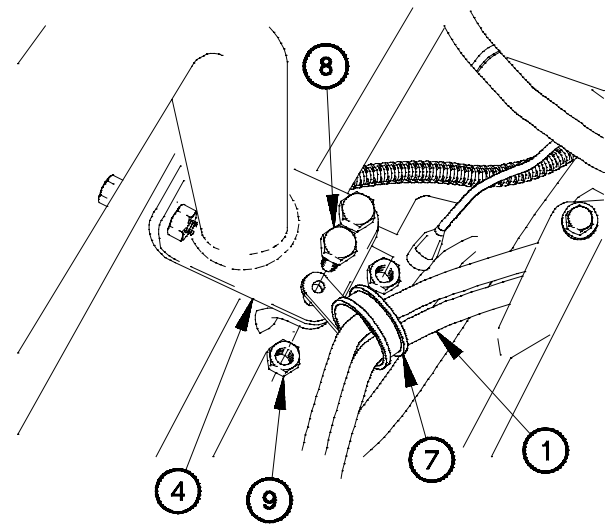

XD09B031

NOTE

Install plastic cable ties as required.

- (8) Connect fuel supply hose assembly (1) to 90-degree fitting (10).

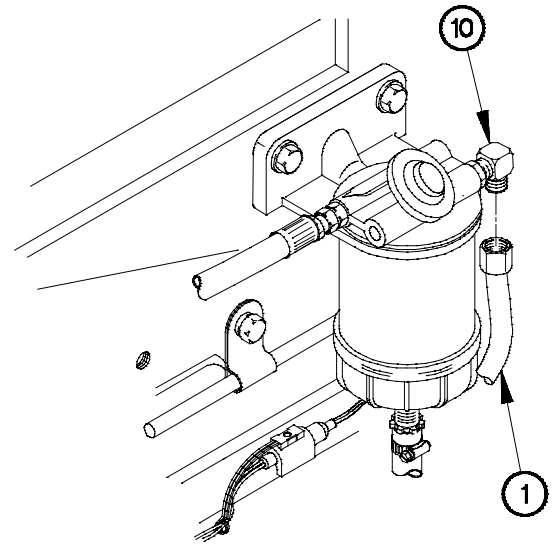

XD09B041

c. Fuel Transfer Hose Removal.

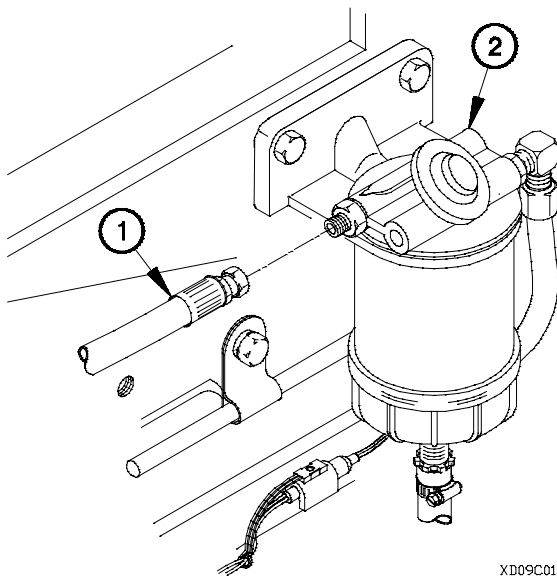

XD09C011

- (1) Disconnect fuel transfer hose assembly (1) from fuel/water separator (2).

- (2) Remove fuel transfer hose assembly (1) from 90-degree fitting (3).

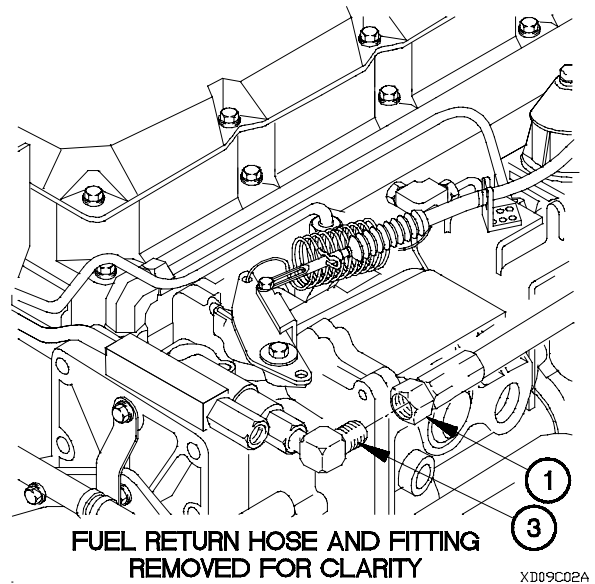

FUEL RETURN HOSE AND FITTING REMOVED FOR CLARITY

XD09C02A

4-9. FUEL HOSES REPLACEMENT (CONT)

d. Fuel Transfer Hose Installation.

- (1) Install fuel transfer hose assembly (1) on 90-degree fitting (2).

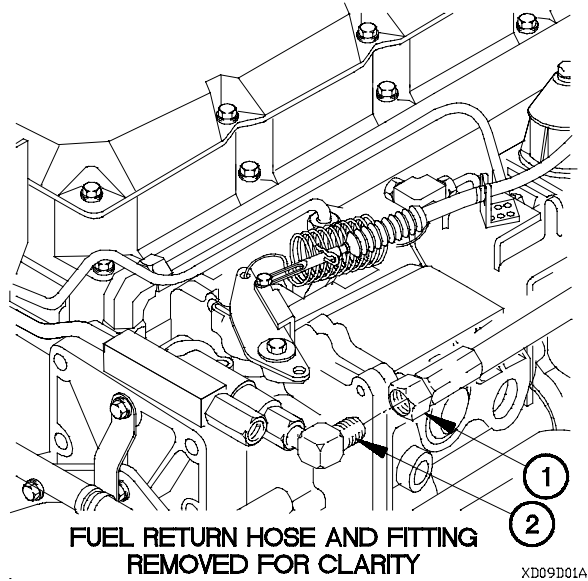
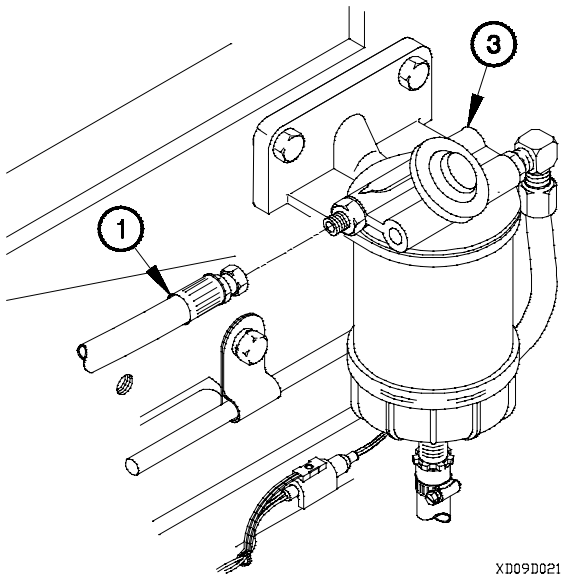

- (2) Connect fuel transfer hose assembly (1) to fuel/water separator (3).

e. Fuel Return Hose Removal.

- (1) Disconnect fuel return hose assembly (1) from 90-degree fitting (2).

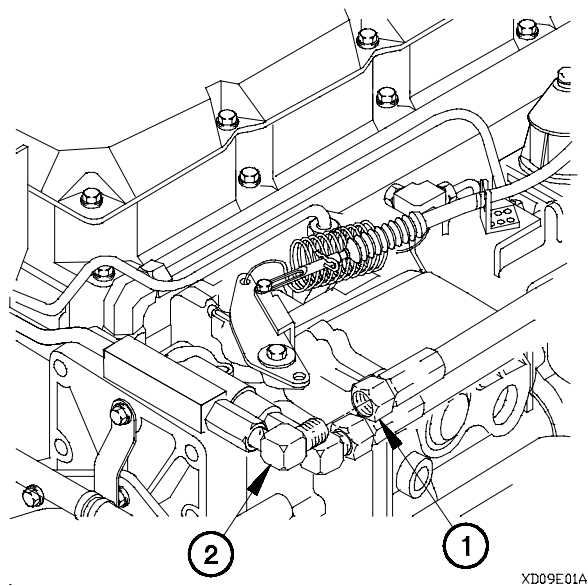

NOTE

- Remove plastic cable ties as required.
- Perform steps (2) and (3) on vehicle serial number 3092 and higher, and vehicle serial numbers 0001 through 3091 that have previously had a spare tire retainer or fuel hose replaced.

(2) Remove self-locking nut (3), screw (4), and clamp (5) from spare tire retainer (6). Discard self-locking nut.

(3) Remove fuel return hose assembly (1) from clamp (5).

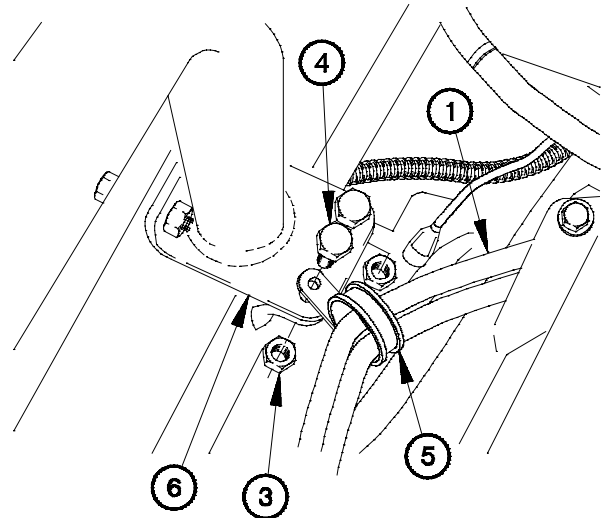

XD09E021

(4) Remove self-locking nut (7), screw (8), and clamp (9) from spare tire retainer (6). Discard self-locking nut.

(5) Remove fuel return hose assembly (1) from clamp (9).

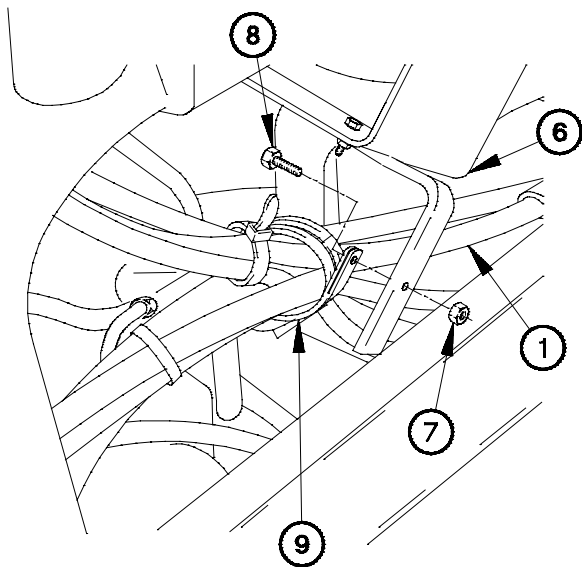

XD09E031

(6) Remove fuel return hose assembly (1) from 90-degree return fitting (10).

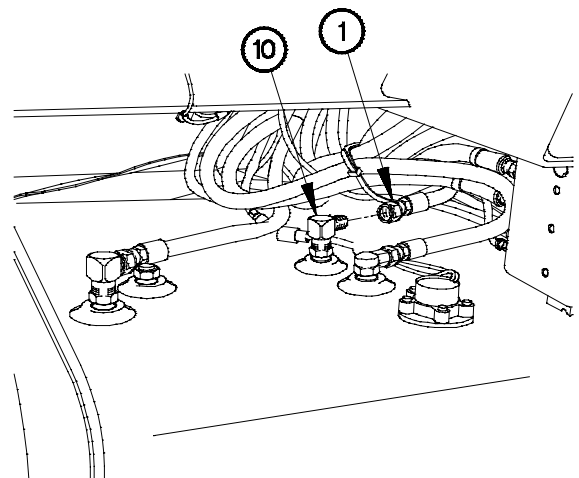

XD09E041

4-9. FUEL HOSES REPLACEMENT (CONT)

f. Fuel Return Hose Installation.

- (1) Install fuel return hose assembly (1) on 90-degree return fitting (2).

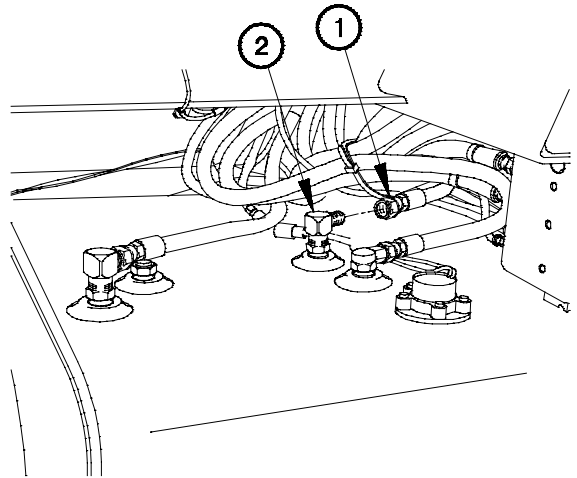

XD09F011

- (2) Install fuel return hose assembly (1) in clamp (3).
- (3) Position clamp (3) on spare tire retainer (4) with screw (5) and self-locking nut (6).
- (4) Tighten self-locking nut (6) to 87-107 lb-in. (10-12 N·m).

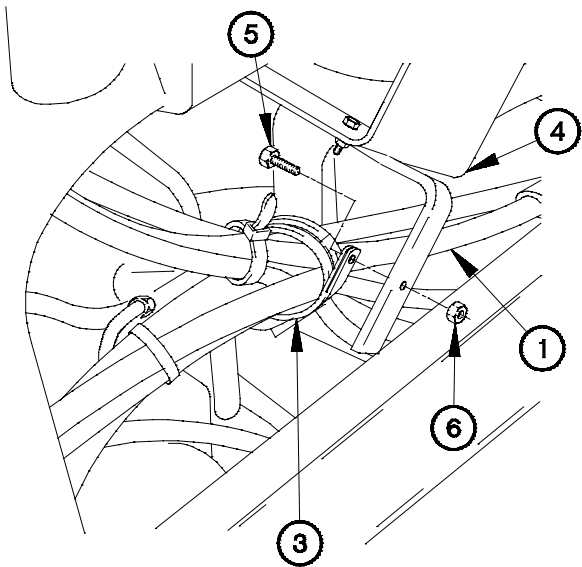

XD09F021

- (5) Install fuel return hose assembly (1) in clamp (7).
- (6) Position clamp (7) on spare tire retainer (4) with screw (8) and self-locking nut (9).
- (7) Tighten self-locking nut (9) to 43-52 lb-ft (58-71 N·m).

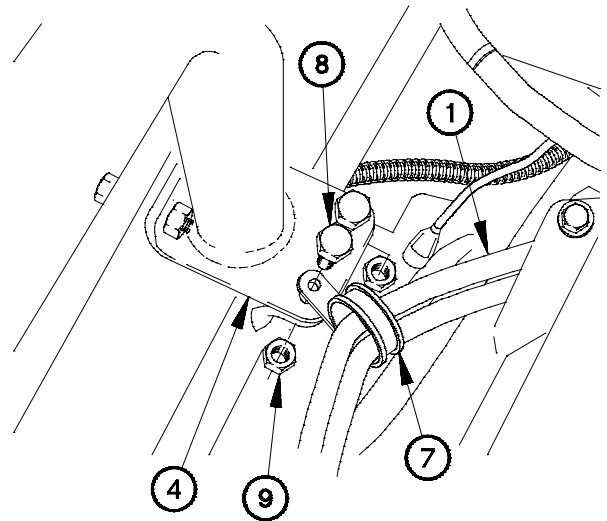

XD09F031

NOTE

Install plastic cable ties as required.

- (8) Connect fuel return hose assembly (1) to 90-degree fitting (10).

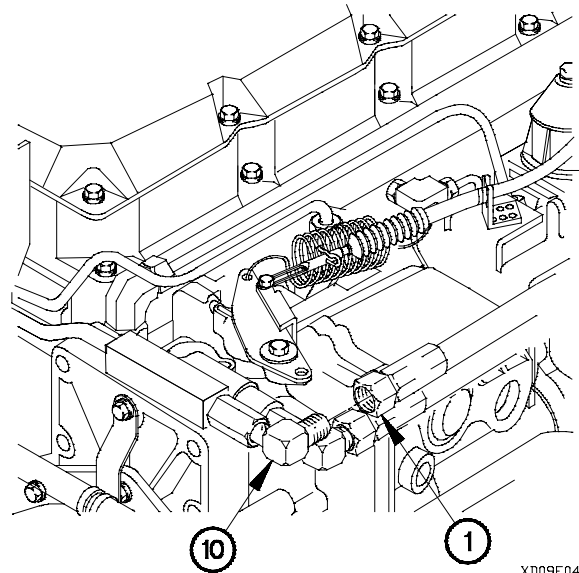

XD09F041

NOTE

Remove plastic cable ties as required.

- (1) Remove self-locking nut (1), screw (2), and clamp (3) from spare tire retainer (4). Discard self-locking nut.
- (2) Remove fuel tank vent hose (5) from clamp (3).

g. Fuel Tank Vent Hose Removal.

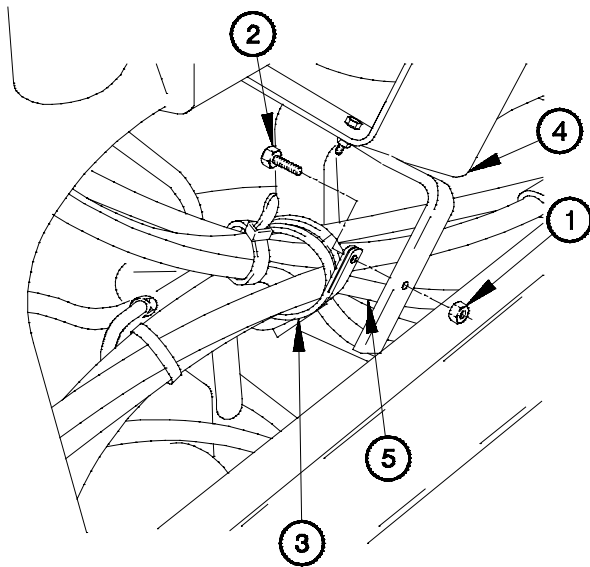

XD09G011

- (3) Remove fuel tank vent hose (5) from relief valve (6).
- (4) Remove adapter (7) from fuel tank vent hose (5).

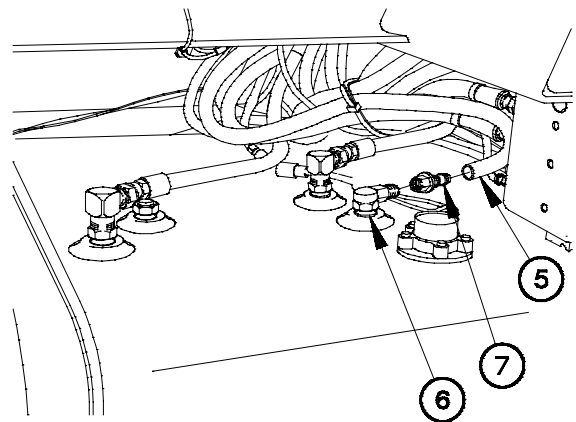

XD09G021.dwg

4-9. FUEL HOSES REPLACEMENT (CONT)

h. Fuel Tank Vent Hose Installation.

- (1) Install adapter (1) in fuel tank vent hose (2).
- (2) Install fuel tank vent hose (2) on relief valve (3).

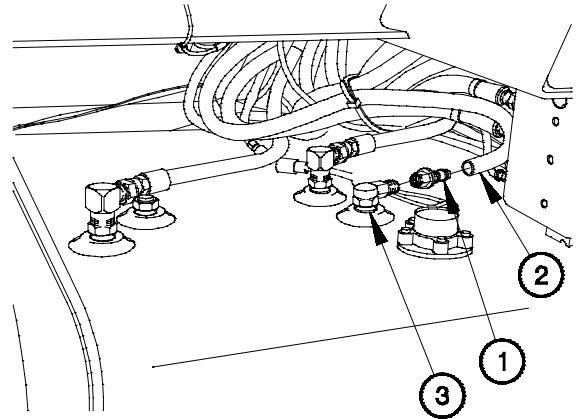

XD09H011

NOTE

Install plastic cable ties as required.

- (3) Form a 180-degree bend in fuel tank vent hose (2).

CAUTION

Use care when installing fuel tank vent hose in clamp so that fuel tank vent hose is not pinched or crimped. Failure to comply may result in damage to equipment.

- (4) Install fuel tank vent hose (2) in clamp (4).
- (5) Position clamp (4) on spare tire retainer (5) with screw (6) and self-locking nut (7).
- (6) Tighten self-locking nut (7) to 87-107 lb-in. (10-12 N·m).

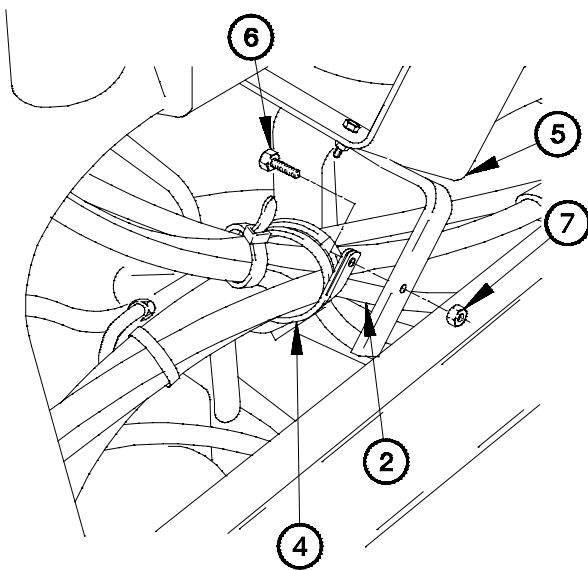

XD09H021

i. Follow-On Maintenance.

- (1) Bleed fuel system (para 4-11).
- (2) Lower cab (TM 9-2320-366-10-1).
- (3) Connect batteries (para 7-57).
- (4) Start engine (TM 9-2320-366-10-1).
- (5) Raise cab (TM 9-2320-366-10-1).
- (6) Check for fuel leaks around hoses and fittings.
- (7) Raise spare tire (TM 9-2320-366-10-2).
- (8) Lower cab (TM 9-2320-366-10-1).
- (9) Shut down engine (TM 9-2320-366-10-1).

End of Task.

4-10. FUEL FILTER TUBES REPLACEMENT	
This task covers:	
a. Removal b. Installation	c. Follow-On Maintenance
INITIAL SETUP	
Equipment Conditions Cab raised (TM 9-2320-366-10-1). Batteries disconnected (para 7-57).	Materials/Parts Packing, Preformed (4) (Item 178, Appendix G) Packing, Preformed (6) (Item 203, Appendix G) Sealant, Pipe Teflon (Item 58, Appendix D)
Tools and Special Tools Tool Kit, Genl Mech (Item 46, Appendix C)	

WARNING

Diesel fuel is flammable. If fuel is spilled, clean it up immediately. Failure to comply may result in serious injury or death to personnel.

a. Removal.

- (1) Disconnect fuel tube assembly (1) from tee fitting (2).
- (2) Remove preformed packing (3) from tee fitting (2). Discard preformed packing.

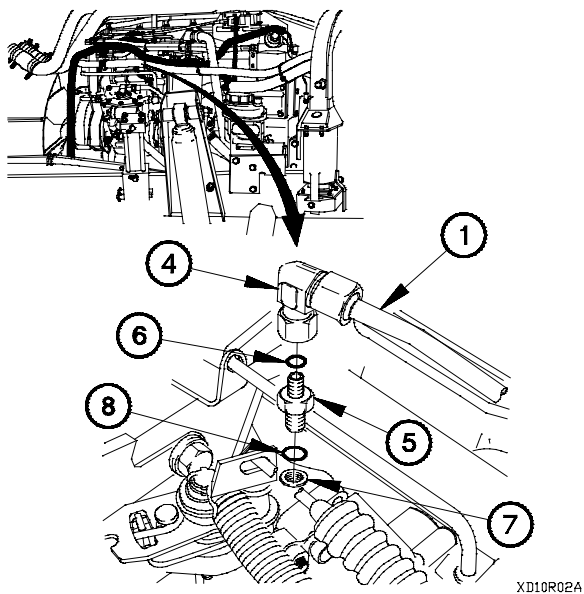
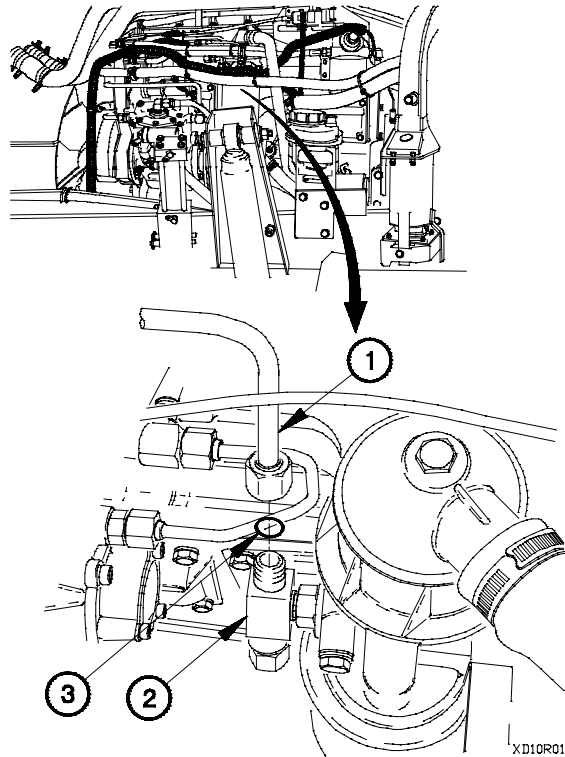

- (3) Remove fuel tube assembly (1) and 90-degree fitting (4) from adapter (5).
- (4) Remove preformed packing (6) from adapter (5). Discard preformed packing.
- (5) Remove adapter (5) from fuel governor (7).
- (6) Remove preformed packing (8) from adapter (5). Discard preformed packing.

4-10. FUEL FILTER TUBES REPLACEMENT (CONT)

- (7) Remove 90-degree fitting (4) from fuel tube assembly (1).
- (8) Remove preformed packing (9) from 90-degree fitting (4). Discard preformed packing.

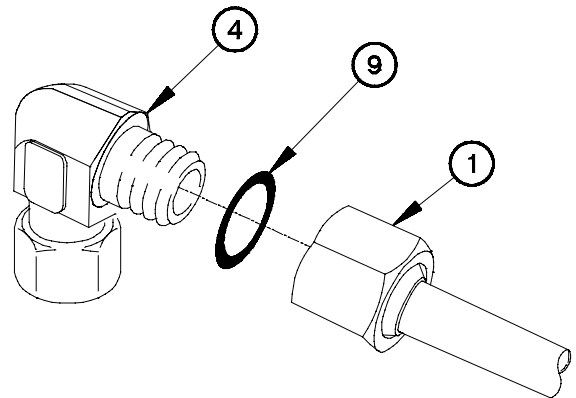

XD10R03-

- (9) Remove screw (10), washer (11), and clip (12) from cylinder head (13).
- (10) Remove clip (12) from fuel tube assembly (14).

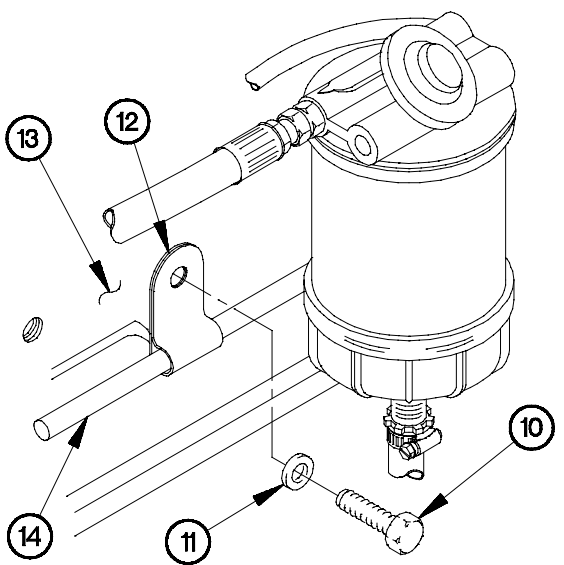

XD10R04-

- (11) Disconnect fuel tube assembly (14) from tee fitting (15).
- (12) Remove preformed packing (16) from tee fitting (15). Discard preformed packing.

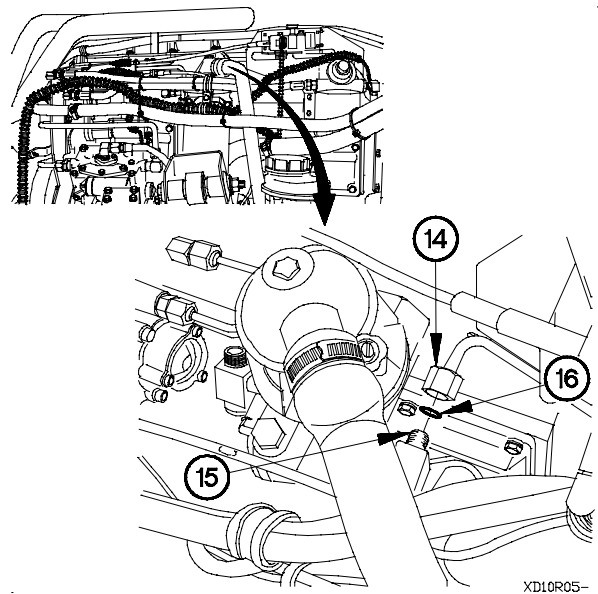

XD10R05-

- (13) Remove fuel tube assembly (14) from 90-degree fitting (17).
- (14) Remove preformed packing (18) from 90-degree fitting (17). Discard preformed packing.

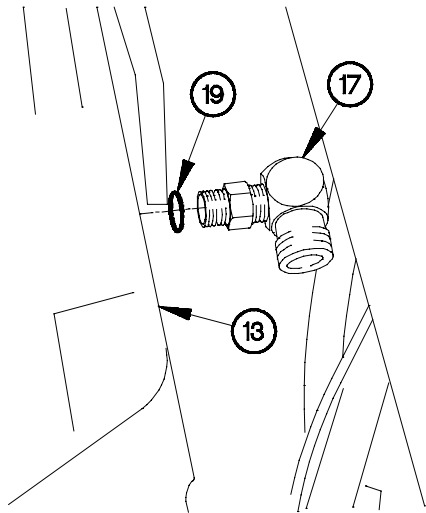
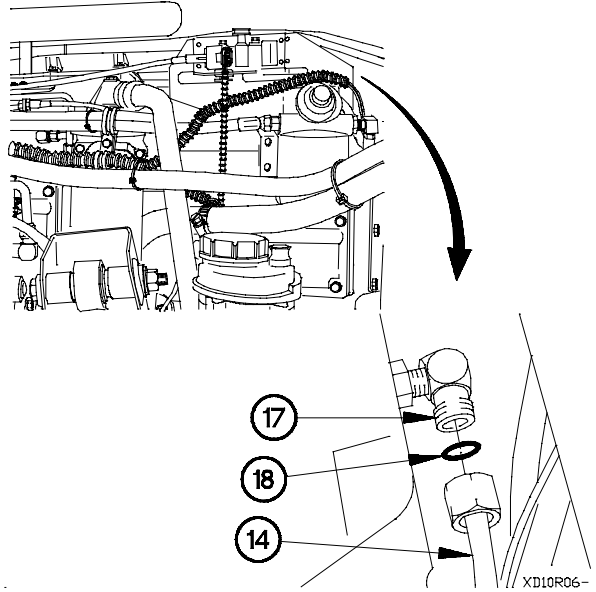

- (15) Remove 90-degree fitting (17) from cylinder head (13).
- (16) Remove preformed packing (19) from 90-degree fitting (17). Discard preformed packing.

- (17) Remove plug (20) from adapter (21).
- (18) Remove adapter (21) from tee fitting (2).
- (19) Remove preformed packing (22) from adapter (21). Discard preformed packing.
- (20) Remove tee fitting (2) from fuel filter base (23).
- (21) Remove preformed packing (24) from tee fitting (2). Discard preformed packing.

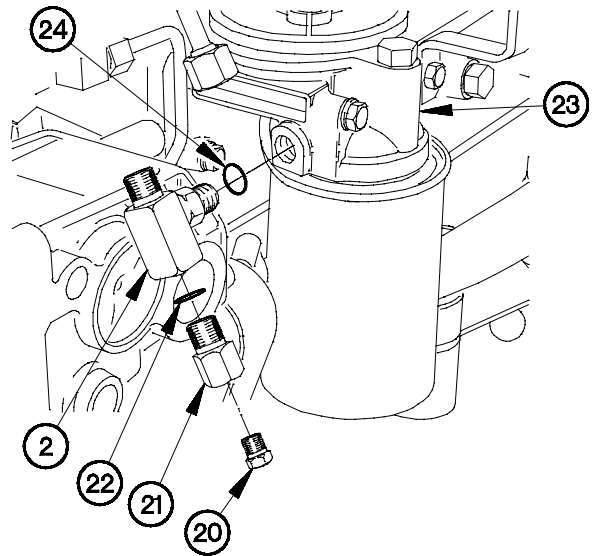

- (22) Remove tee fitting (15) from fuel filter base (23).
- (23) Remove preformed packing (25) from tee fitting (15). Discard preformed packing.

b. Installation.

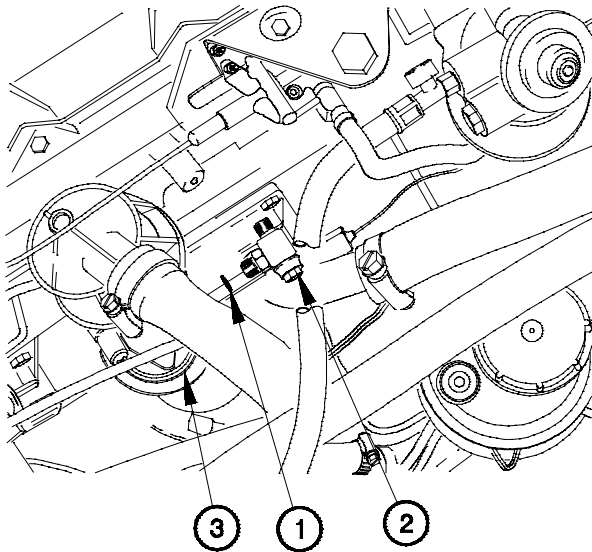

XDI0101-

- (3) Install preformed packing (4) on tee fitting (5).
- (4) Install tee fitting (5) in fuel filter base (3).
- (5) Install preformed packing (6) on adapter (7).
- (6) Install adapter (7) in tee fitting (5).

WARNING

Adhesives, solvents, and sealing compounds can burn easily, can give off harmful vapors, and are harmful to skin and clothing. Keep away from open fire and use in a well-ventilated area. If adhesive, solvent, or sealing compound gets on skin or clothing, wash immediately with soap and water. Failure to comply may result in injury to personnel.

- (6.1) Apply sealing compound to threads of plug (8).
- (7) Install plug (8) in adapter (7).

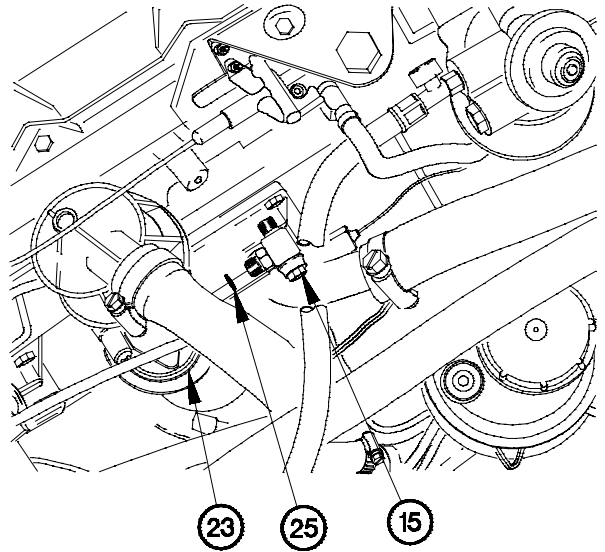

XDI0R09A

- (1) Install preformed packing (1) on tee fitting (2).
- (2) Install tee fitting (2) in fuel filter base (3).

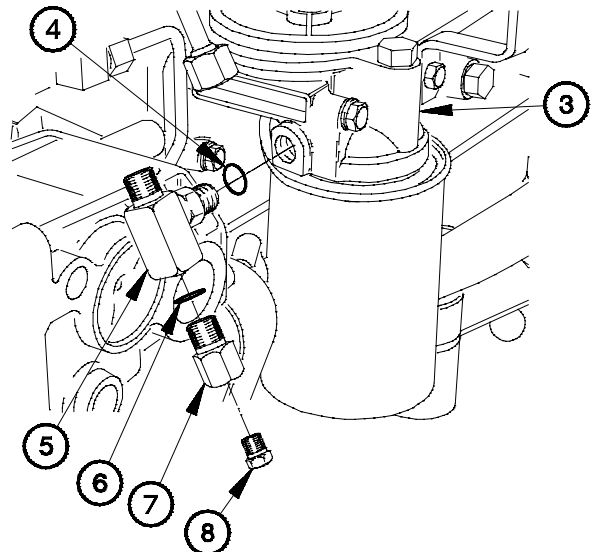

XDI0102A

- (8) Install preformed packing (9) on 90-degree fitting (10).
- (9) Install 90-degree fitting (10) in cylinder head (11).

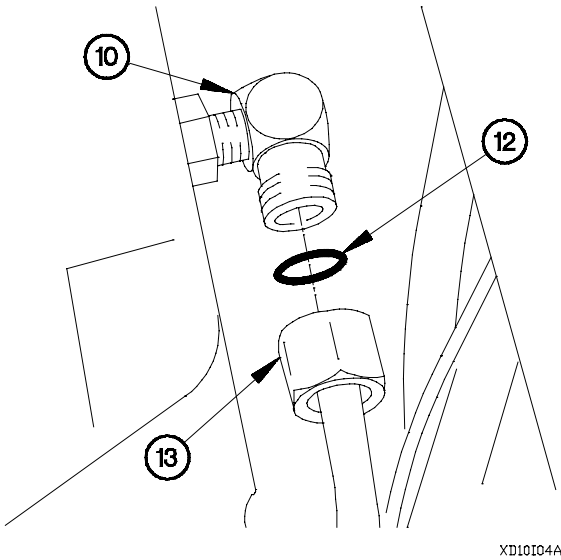
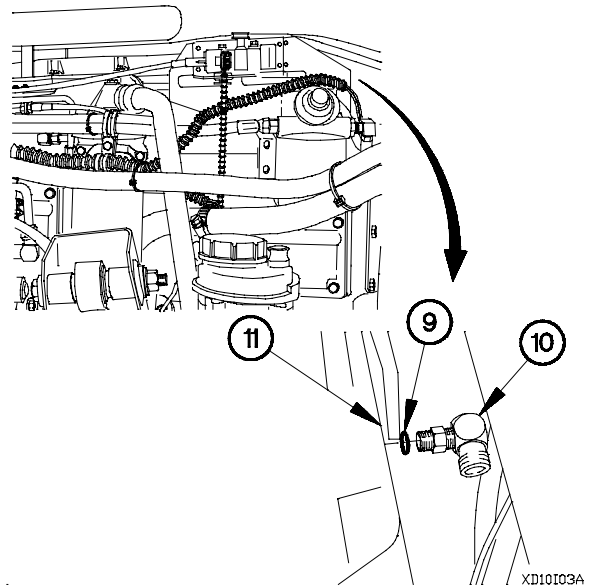

- (10) Install preformed packing (12) on 90-degree fitting (10).
- (11) Install fuel tube assembly (13) on 90-degree fitting (10).

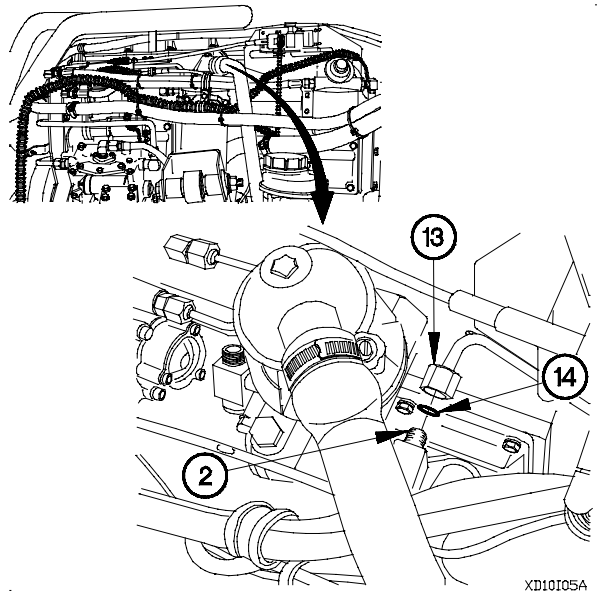

- (12) Install preformed packing (14) on tee fitting (2).
- (13) Install fuel tube assembly (13) on tee fitting (2).

4-10. FUEL FILTER TUBES REPLACEMENT (CONT)

- (14) Install clip (15) on fuel tube assembly (13).
- (15) Install clip (15) on cylinder head (11) with washer (16) and screw (17).

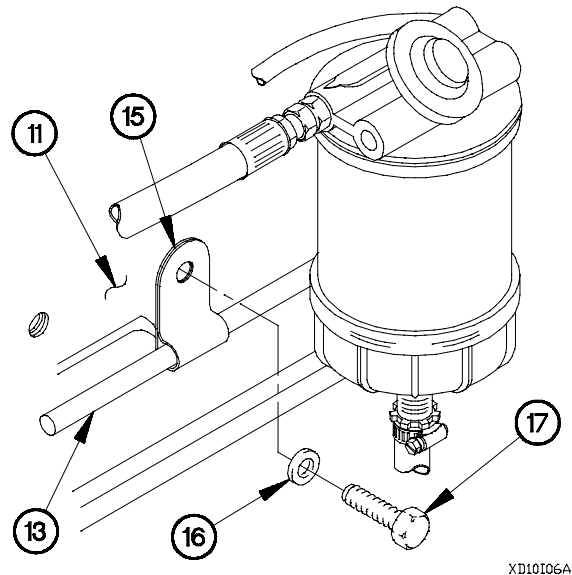

XD10106A

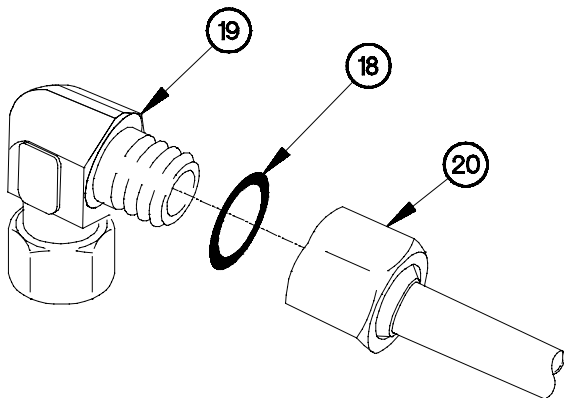

XD10107A

- (16) Install preformed packing (18) on 90-degree fitting (19).
- (17) Install fuel tube assembly (20) on 90-degree fitting (19).

- (18) Install preformed packing (21) on adapter (22).
- (19) Install adapter (22) in fuel governor (23).
- (20) Install preformed packing (24) on adapter (22).
- (21) Install 90-degree fitting (19) on adapter (22).

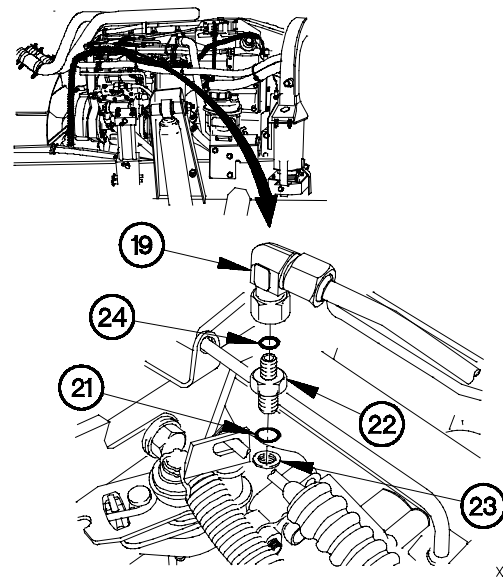

XD10108A

- (22) Install preformed packing (25) on tee fitting (5).
- (23) Install fuel tube assembly (20) on tee fitting (5).

c. Follow-On Maintenance.

- (1) Lower cab (TM 9-2320-366-10-1).
- (2) Connect batteries (para 7-57).
- (3) Start engine (TM 9-2320-366-10-1).
- (4) Check for fuel leaks under vehicle.
- (5) Raise cab (TM 9-2320-366-10-1).
- (6) Check for fuel leaks around tubes and fittings.
- (7) Lower cab (TM 9-2320-366-10-1).
- (8) Shut down engine (TM 9-2320-366-10-1).

End of Task.

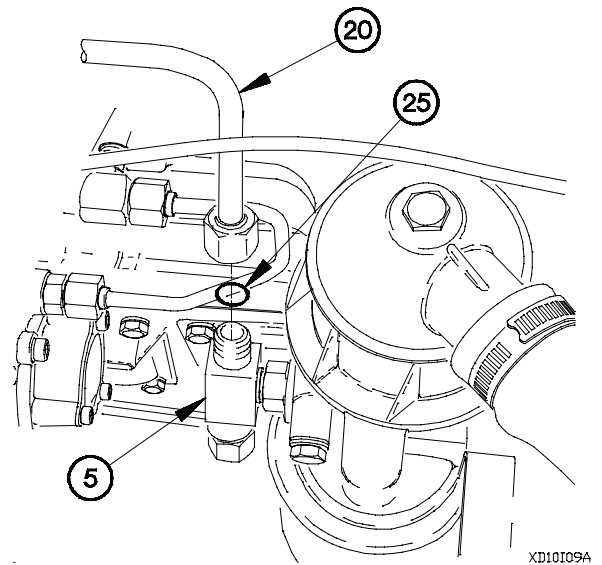

4-11. FUEL SYSTEM BLEEDING

This task covers:

- a. Bleeding b. Follow-On Maintenance

INITIAL SETUP

Equipment Conditions

Engine shut down (TM 9-2320-366-10-1).
Cab raised (TM 9-2320-366-10-1).

Tools and Special Tools

Tool Kit, Genl Mech (Item 46, Appendix C)
Pan, Drain (Item 24, Appendix C)

Materials/Parts

Ties, Cable, Plastic (Item 69, Appendix D)

WARNING

Diesel fuel is flammable. If fuel is spilled, clean it up immediately. Failure to comply may result in serious injury or death to personnel.

a. Bleeding.

NOTE

Remove plastic cable ties as required.

- (1) Position drain pan below fuel return hose assembly (1).
- (2) Disconnect fuel return hose assembly (1) from 90-degree fitting (2).
- (3) Direct fuel return hose assembly (1) into drain pan.

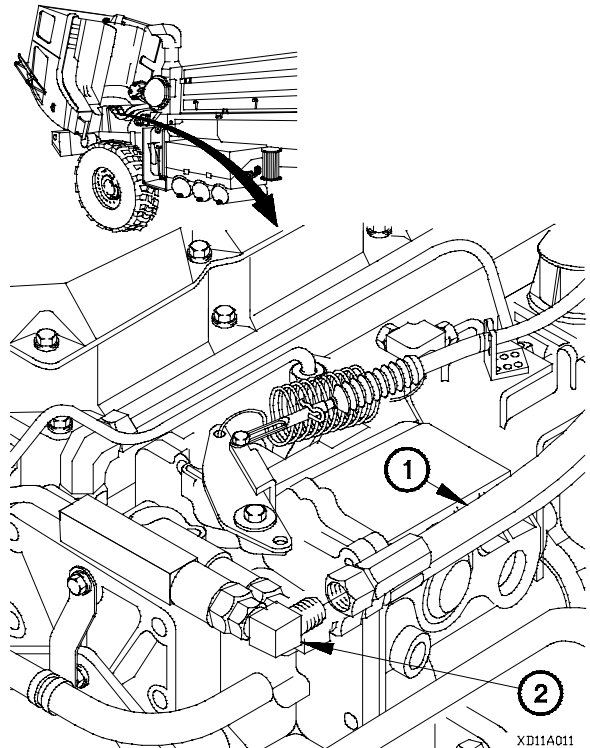

4-11. FUEL SYSTEM BLEEDING (CONT)

(4) Depress button (3) on fuel/water separator (4) as many times as necessary to get a steady stream of clear fuel.

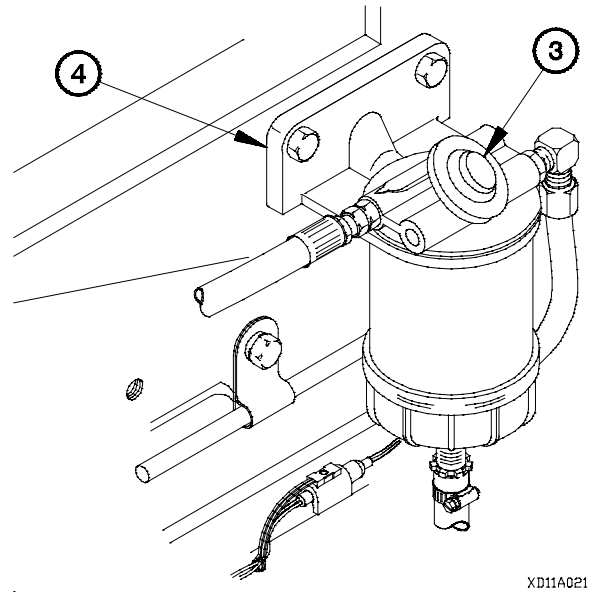

XD11A021

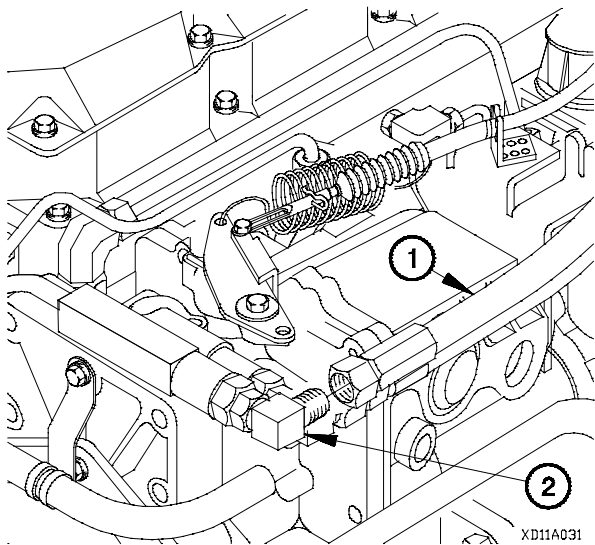

XD11A031

NOTE

Install plastic cable ties as required.

(5) Connect fuel return hose assembly (1) to 90-degree fitting (2).

b. Follow-On Maintenance.

- (1) Lower cab (TM 9-2320-366-10-1).
- (2) Start engine and allow to run until engine runs smoothly (TM 9-2320-366-10-1).
- (3) Shut down engine (TM 9-2320-366-10-1).

End of Task.

4-12. GOVERNOR LINKAGE REPLACEMENT

This task covers:

- | | |
|----------------|--------------------------|
| a. Removal | d. Installation |
| b. Disassembly | e. Follow-On Maintenance |
| c. Assembly | |

INITIAL SETUP

Equipment Conditions

- Engine shut down (TM 9-2320-366-10-1).
- Cab raised (TM 9-2320-366-10-1).

Materials/Parts

- Pin, Cotter (Item 224, Appendix G)
- Bushing, Sleeve (Item 6, Appendix G)

Tools and Special Tools

- Tool Kit, Genl Mech (Item 46, Appendix C)

a. Removal.

- (1) Remove cotter pin (1), washer (2), and TPS cable assembly (3) from stud (4). Discard cotter pin.
- (2) Remove clip (5) and throttle control cable (6) from stud (7).

NOTE

Note position of two springs prior to removal.

- (3) Remove springs (8 and 9) from linkage plate (10).

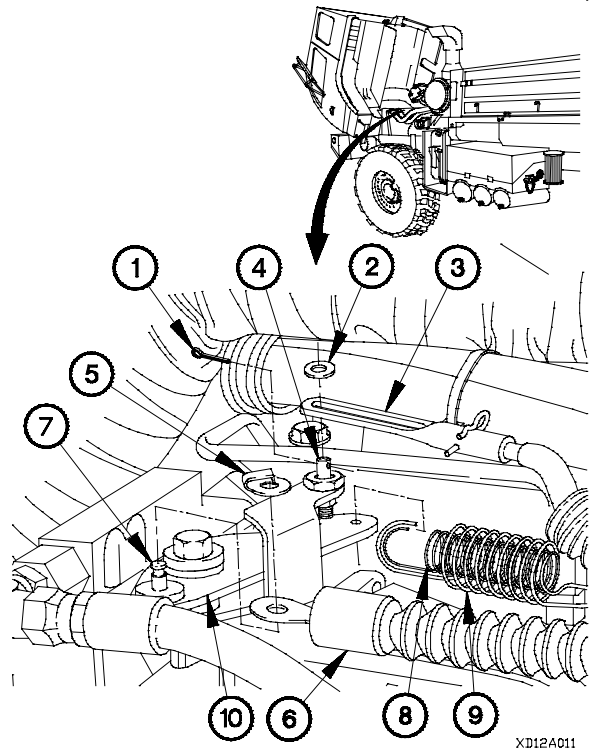
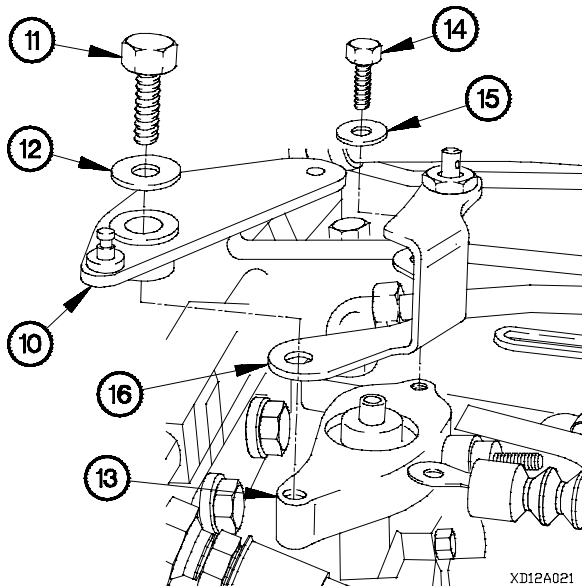

- (4) Remove bolt (11), washer (12), and linkage plate (10) from governor (13).
- (5) Remove bolt (14), washer (15), and sensor bracket (16) from governor (13).

4-12. GOVERNOR LINKAGE REPLACEMENT (CONT)

b. Disassembly.

(1) Remove ring spacer (1) from linkage plate (2). Discard ring spacer.

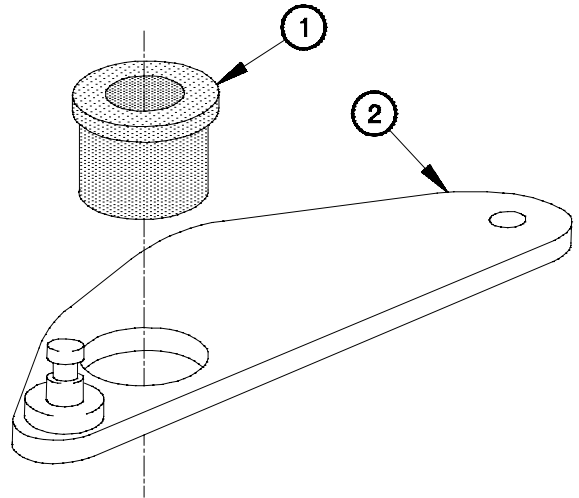

XD12B011

(2) Remove nut (3), washer (4), and stud (5) from sensor bracket (6).

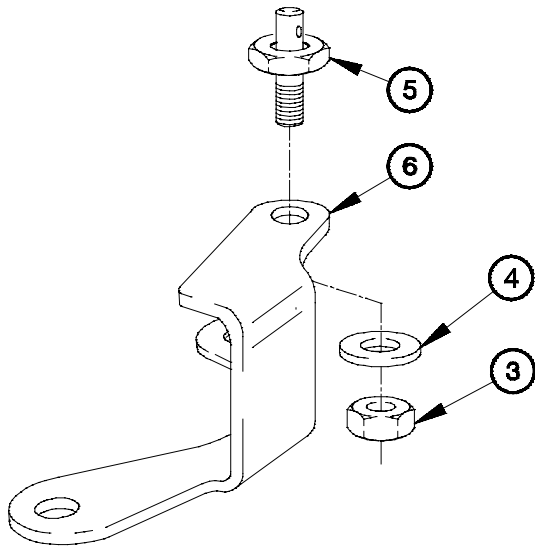

XD12B021

c. Assembly.

(1) Install stud (1), washer (2), and nut (3) on sensor bracket (4).

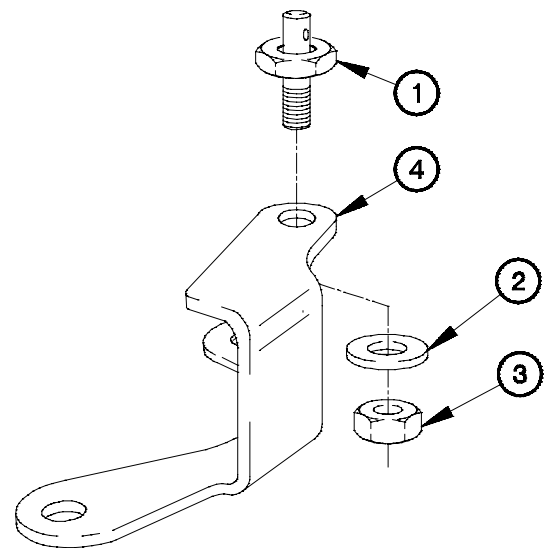

XD12C011

(2) Install ring spacer (5) in linkage plate (6).

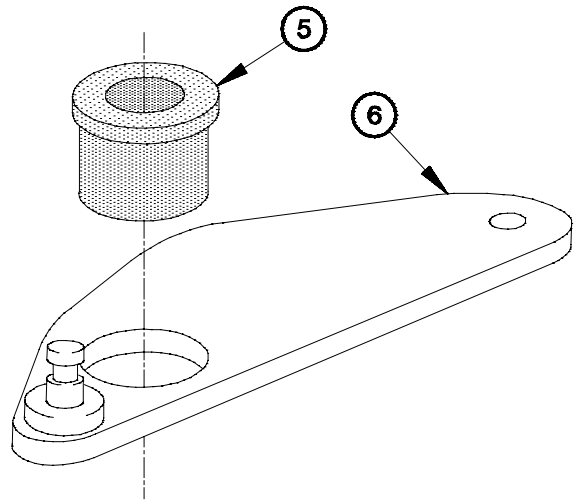

XD12C021

d. Installation.

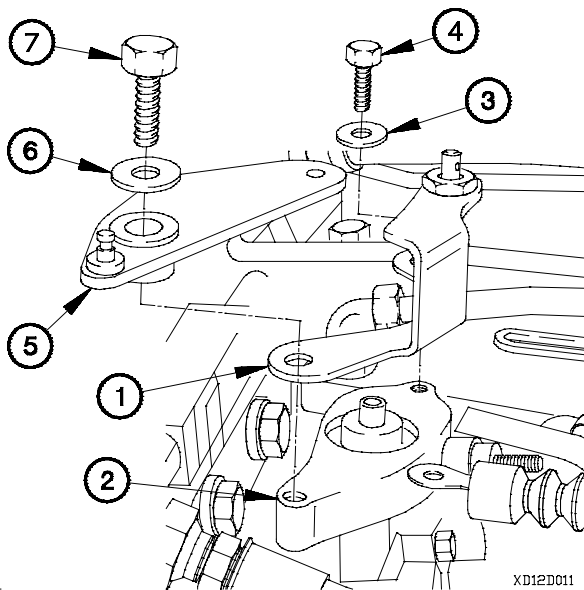

XD12D011

- (1) Position sensor bracket (1) on governor (2) with washer (3) and bolt (4).
- (2) Tighten bolt (4) to 9 lb-ft (12 N-m).
- (3) Position linkage plate (5) on governor (2) with washer (6) and bolt (7).
- (4) Tighten bolt (7) to 20 lb-ft (27 N-m).

(5) Install springs (8 and 9) on linkage plate (5).

(6) Install throttle control cable (10) on stud (11) with clip (12).

(7) Install TPS cable assembly (13) on stud (14) with washer (15) and cotter pin (16).

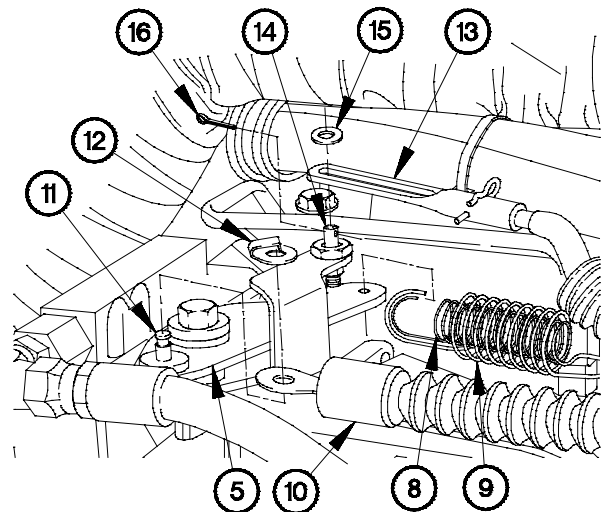

XD12D021

e. Follow-On Maintenance.

(1) Lower cab (TM 9-2320-366-10-1).

(2) Operate vehicle and check for proper engine operation (TM 9-2320-366-10-1).

End of Task.

4-13. FUEL/WATER SEPARATOR AND FILTER REPLACEMENT

This task covers:

- a. Filter Removal
- b. Filter Installation
- c. Pump Head Removal
- d. Pump Head Installation
- e. Follow-On Maintenance

INITIAL SETUP

<p>Equipment Conditions Cab raised (TM 9-2320-366-10-1). Batteries disconnected (para 7-57).</p> <p>Tools and Special Tools Tool Kit, Genl Mech (Item 46, Appendix C) Pan, Drain (Item 24, Appendix C)</p>	<p>Materials/Parts Cloth, Cleaning (Item 16, Appendix D) Oil, Fuel, Diesel (Item 36 or 37, Appendix D) Filter Element, Fluid (Item 17, Appendix G) Packing, Preformed (2) (Item 200, Appendix G)</p>
--	---

WARNING

Diesel fuel is flammable. If fuel is spilled, clean it up immediately. Failure to comply may result in serious injury or death to personnel.

a. Filter Removal.

- (1) Disconnect connector clamp (1) from fuel/water separator connector (2).
- (2) Disconnect connector P33 (3) from fuel/water separator connector (2).
- (3) Position drain pan under hose (4).
- (4) Open drain valve (5) and allow fuel to drain.
- (5) Loosen clamp (6) on hose (4).
- (6) Remove hose (4) from drain valve (5).

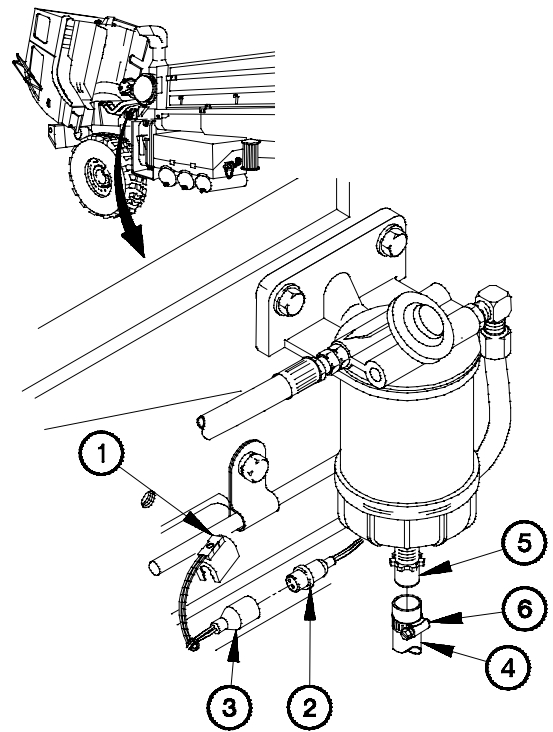

XD13A011

- (7) Remove fluid filter element (7) and bowl assembly (8) from pump head (9).
- (8) Remove bowl assembly (8) from fluid filter element (7). Discard fluid filter element.
- (9) Remove preformed packing (10) from bowl assembly (8). Discard preformed packing.
- (10) Clean debris from valve (11) on bottom of pump head (9).

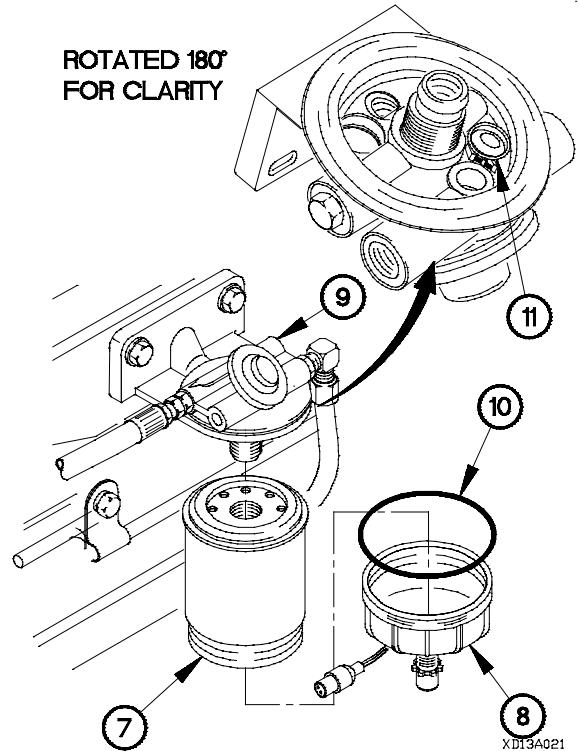

b. Filter Installation.

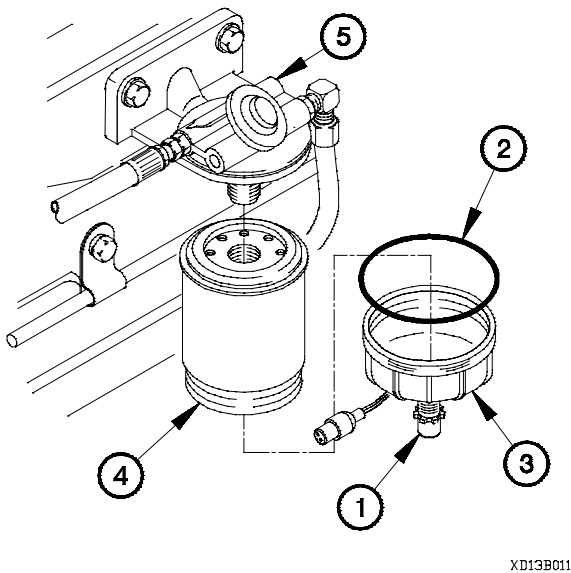

- (1) Close drain valve (1).
- (2) Install preformed packing (2) on bowl assembly (3).
- (3) Install bowl assembly (3) on fluid filter element (4).
- (4) Install fluid filter element (4) on pump head (5).

- (5) Install hose (6) on drain valve (1) with clamp (7).
- (6) Connect connector P33 (8) to fuel/water separator connector (9).
- (7) Connect connector clamp (10) on fuel/water separator connector (9).

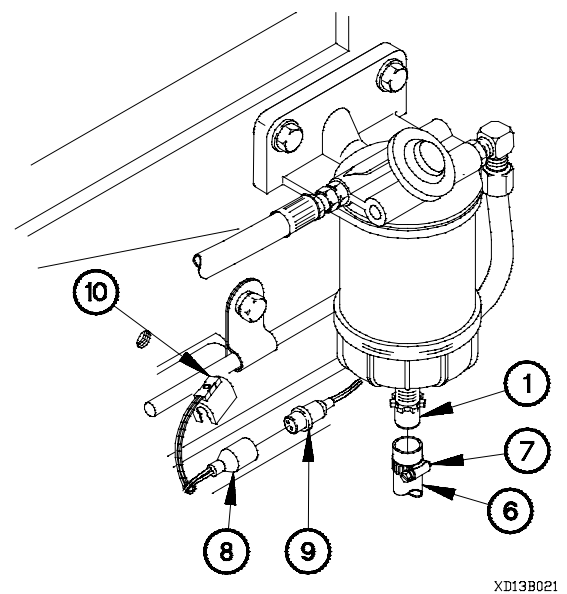

4-13. FUEL/WATER SEPARATOR AND FILTER REPLACEMENT (CONT)

c. Pump Head Removal.

- (1) Disconnect fuel transfer hose assembly (1) from adapter (2).
- (2) Remove adapter (2) and preformed packing (3) from pump head (4). Discard preformed packing.
- (3) Disconnect fuel supply hose assembly (5) from 90-degree fitting (6).
- (4) Remove 90-degree fitting (6) and preformed packing (7) from pump head (4). Discard preformed packing.

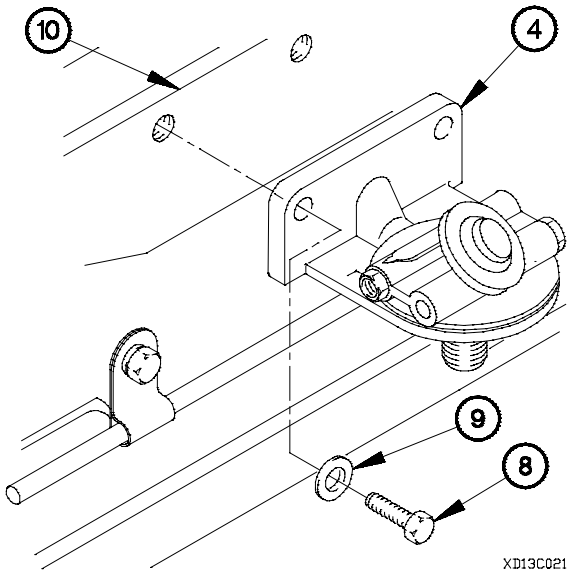
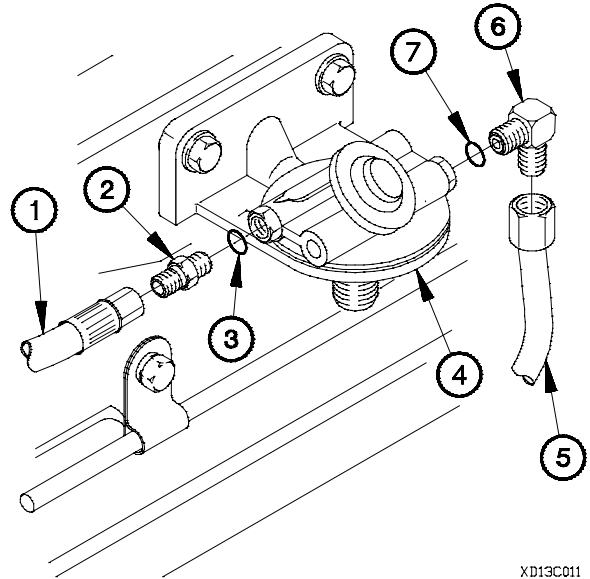

- (5) Remove two screws (8), washers (9), and pump head (4) from bracket (10).

d. Pump Head Installation.

- (1) Install pump head (1) on bracket (2) with two washers (3) and screws (4).

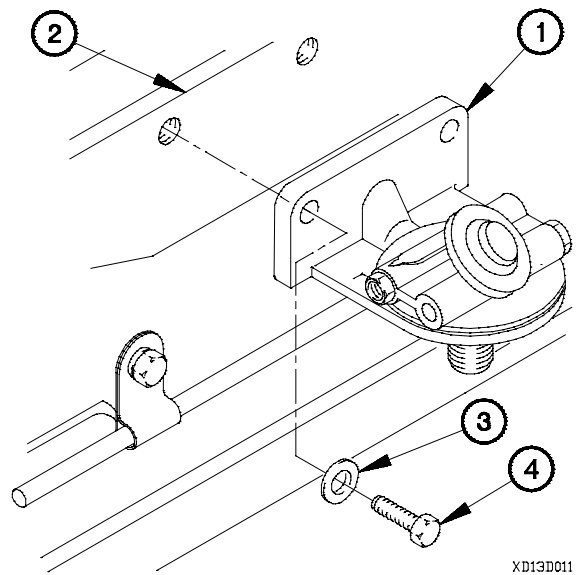

- (2) Install preformed packing (5) on 90-degree fitting (6).
- (3) Install 90-degree fitting (6) in pump head (1).
- (4) Install fuel supply hose assembly (7) on 90-degree fitting (6).
- (5) Install preformed packing (8) on adapter (9).
- (6) Install adapter (9) in pump head (1).
- (7) Install fuel transfer hose assembly (10) on adapter (9).

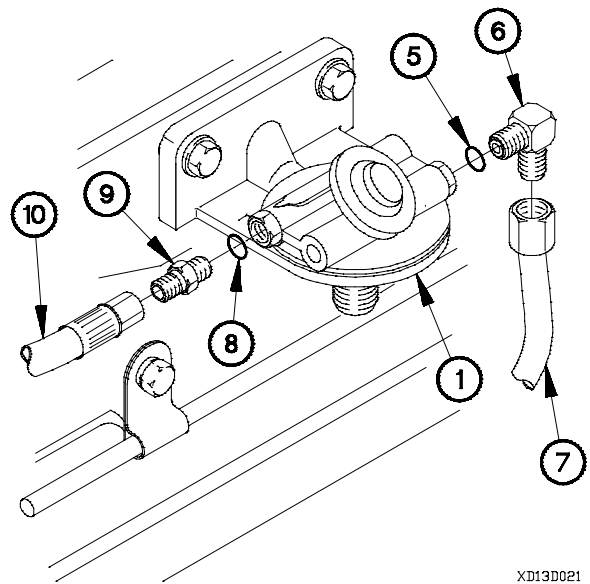

XD13D021

e. Follow-On Maintenance.

- (1) Bleed fuel system (para 4-11).
- (2) Lower cab (TM 9-2320-366-10-1).
- (3) Connect batteries (para 7-57).
- (4) Start engine (TM 9-2320-366-10-1).
- (5) Check for fuel leaks under vehicle.
- (6) Raise cab (TM 9-2320-366-10-1).
- (7) Check engine compartment for fuel leaks.
- (8) Lower cab (TM 9-2320-366-10-1).
- (9) Shut down engine (TM 9-2320-366-10-1).

End of Task.

4-14. FUEL FILTER AND FILTER BASE REPLACEMENT

This task covers:

- a. Filter Removal
- b. Filter Installation
- c. Filter Base Removal
- d. Filter Base Installation
- e. Follow-On Maintenance

INITIAL SETUP

<p>Equipment Conditions Cab raised (TM 9-2320-366-10-1). Batteries disconnected (para 7-57).</p> <p>Tools and Special Tools Pan, Drain (Item 24, Appendix C) Tool Kit, Genl Mech (Item 46, Appendix C) Wrench, Torque, 0-200 lb-in. (Item 59, Appendix C) Socket Set, Socket Wrench (Item 36, Appendix C) Wrench, Strap, Adjustable (Item 57, Appendix C)</p>	<p>Materials/Parts Oil, Fuel, Diesel (Item 36 or 37, Appendix D) Filter, Fuel (Item 22, Appendix G) Packing, Preformed (2) (Item 178, Appendix G) Packing, Preformed (3) (Item 203, Appendix G) Packing, Preformed (Item 207, Appendix G) Gasket, Fuel Filter (Item 44, Appendix G)</p>
--	--

WARNING

Diesel fuel is flammable. If fuel is spilled, clean it up immediately. Failure to comply may result in serious injury or death to personnel.

a. Filter Removal.

- (1) Position drain pan under filter element (1).
- (2) Remove filter element (1) from fuel filter base (2).

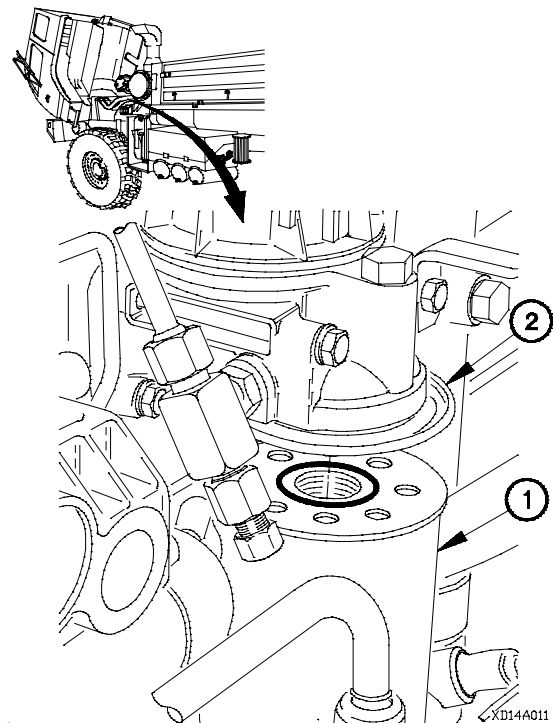

b. Filter Installation.

- (1) Coat filter element seal (1) with a light coat of fuel.
- (2) Fill filter element (2) with diesel fuel.
- (3) Install filter element (2) on fuel filter base (3). Then turn 3/4-turn after filter element touches fuel filter base.

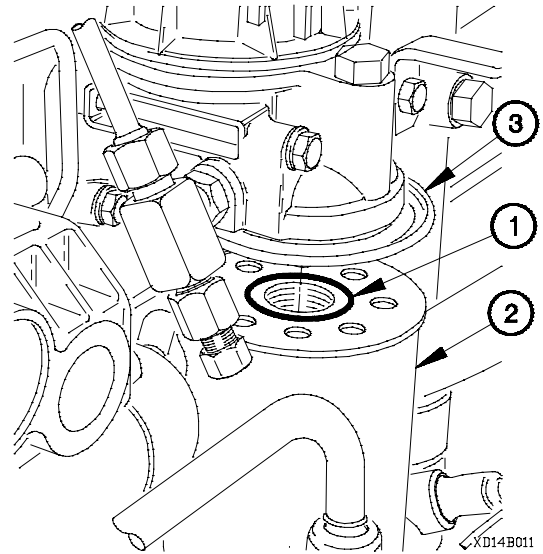

c. Filter Base Removal.

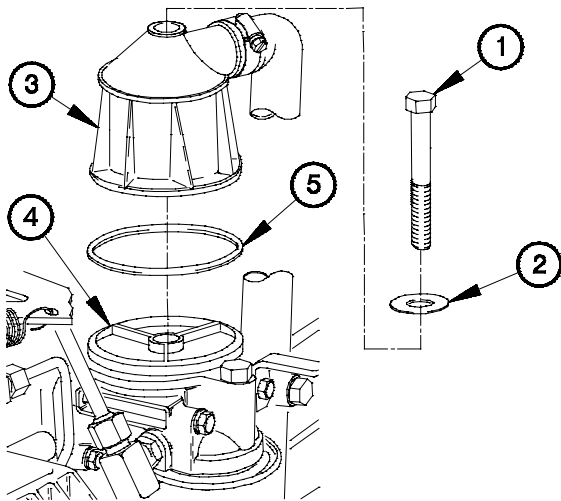

- (1) Remove screw (1) and washer (2) from top of crankcase breather (3).
- (2) Remove crankcase breather (3) from fuel filter base (4).
- (3) Remove preformed packing (5) from fuel filter base (4). Discard preformed packing.

- (4) Disconnect fuel tube assembly (6) from tee fitting (7).
- (5) Remove preformed packing (8) from tee fitting (7). Discard preformed packing.

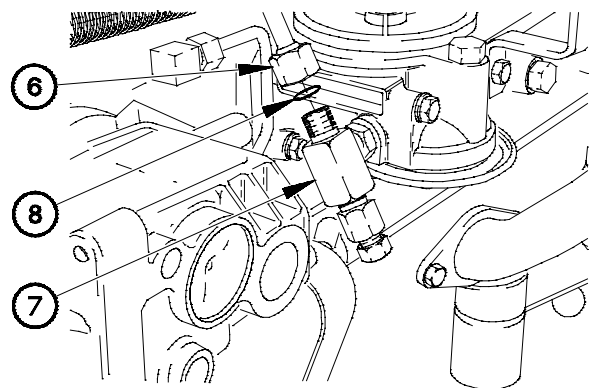

XD14C021

4-14. FUEL FILTER AND FILTER BASE REPLACEMENT (CONT)

- (6) Remove tee fitting (7) from fuel filter base (4).
- (7) Remove preformed packing (9) from tee fitting (7). Discard preformed packing.

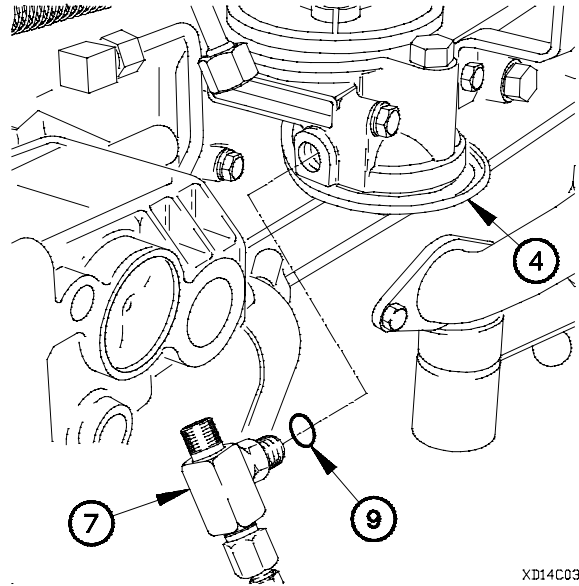

XDI4C031

- (8) Disconnect fuel tube assembly (10) from tee fitting (11).
- (9) Remove preformed packing (12) from tee fitting (11). Discard preformed packing.
- (10) Remove tee fitting (11) from fuel filter base (4).
- (11) Remove preformed packing (13) from tee fitting (11). Discard preformed packing.

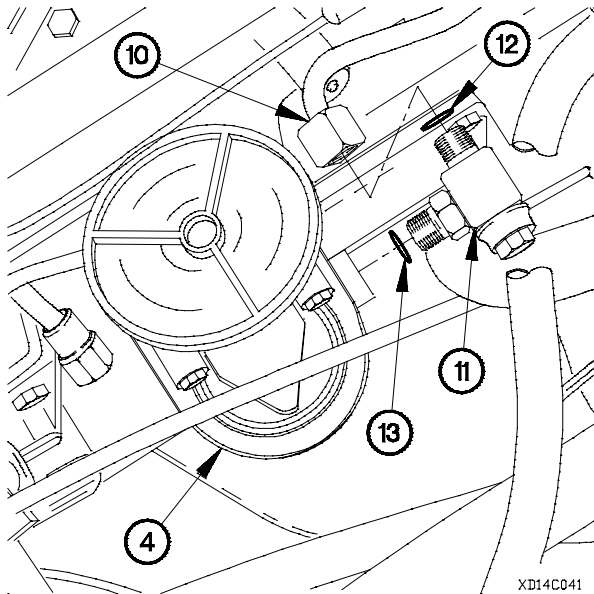

XDI4C041

- (12) Remove four screws (14) and washers (15) from fuel filter base (4).
- (13) Remove fuel filter base (4) and gasket (16) from engine (17). Discard gasket.
- (14) Remove plug (18) from fuel filter base (4).
- (15) Remove preformed packing (19) from plug (18). Discard preformed packing.

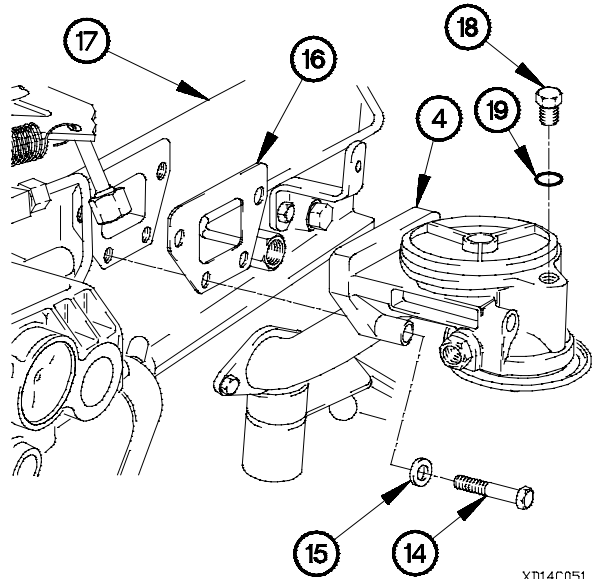

XDI4C051

d. Filter Base Installation.

- (1) Install preformed packing (1) on plug (2).
- (2) Install plug (2) in fuel filter base (3).
- (3) Position fuel filter base (3) and gasket (4) on engine (5) with four washers (6) and screws (7).
- (4) Tighten four screws (7) to 96-144 lb-in. (11-16 N·m).

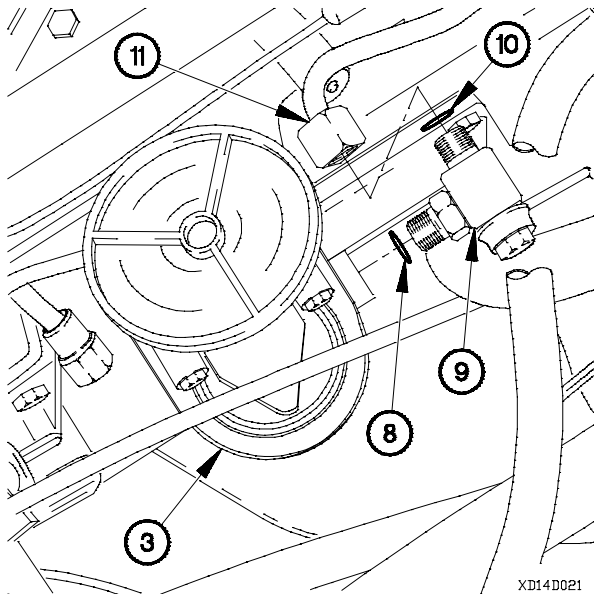
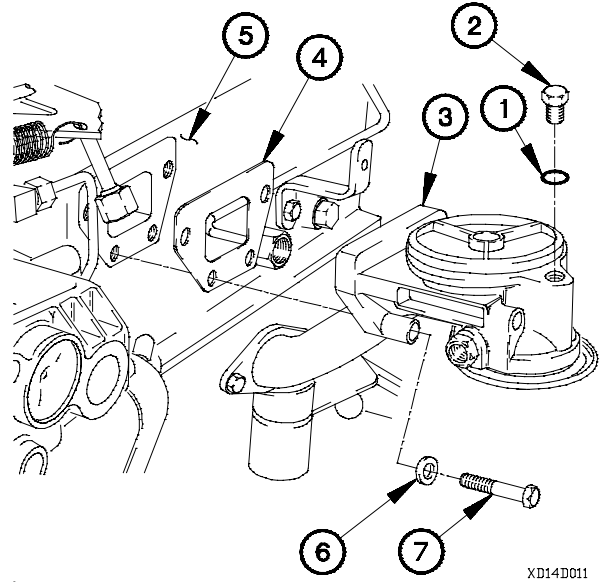

- (5) Install preformed packing (8) on tee fitting (9).
- (6) Install tee fitting (9) in fuel filter base (3).
- (7) Install preformed packing (10) on tee fitting (9).
- (8) Connect fuel tube assembly (11) to tee fitting (9).

- (9) Install preformed packing (12) on tee fitting (13).
- (10) Install tee fitting (13) in fuel filter base (3).

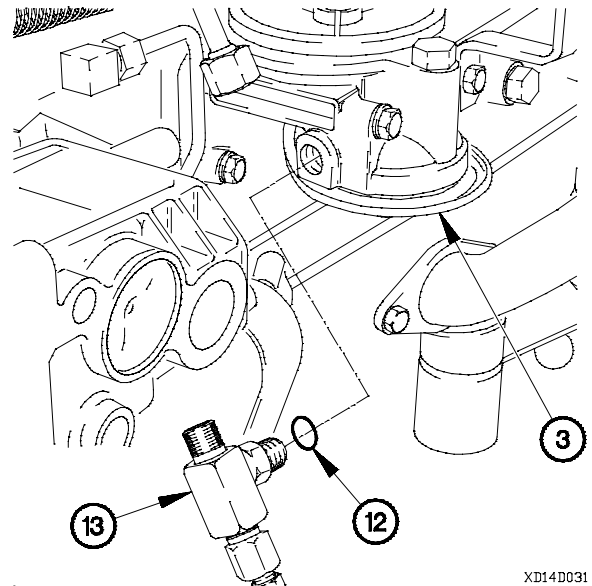

4-14. FUEL FILTER AND FILTER BASE REPLACEMENT (CONT)

- (11) Install preformed packing (14) on tee fitting (13).
- (12) Connect fuel tube assembly (15) to tee fitting (13).

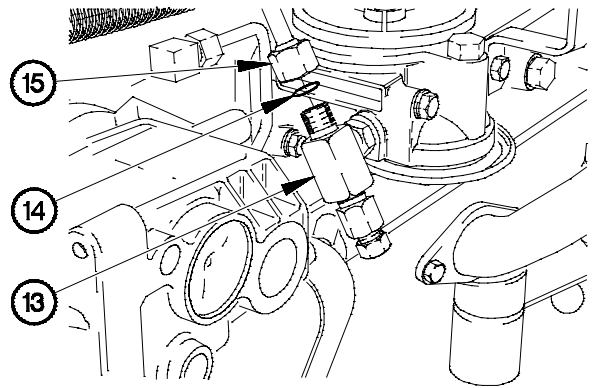

XD14D041

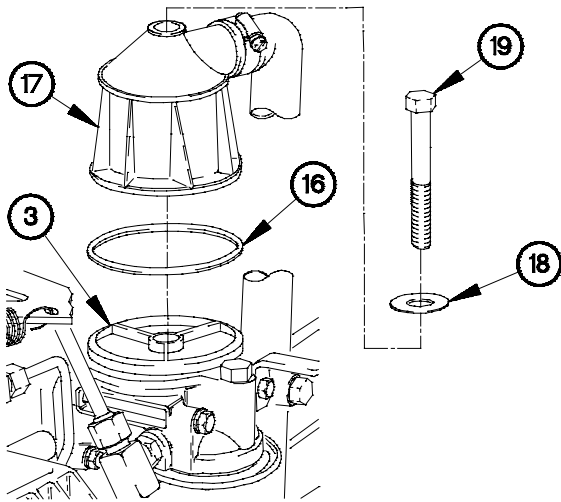

XD14D051

- (13) Apply thin coat of lubricating oil to both sides of preformed packing (16).
- (14) Install preformed packing (16) on top of fuel filter base (3).
- (15) Position crankcase breather (17) on top of fuel filter base (3) with washer (18) and screw (19).
- (16) Tighten screw (19) to 96-144 lb-in. (11-16 N-m).

e. Follow-On Maintenance.

- (1) Bleed fuel system (para 4-11).
- (2) Lower cab (TM 9-2320-366-10-1).
- (3) Connect batteries (para 7-57).
- (4) Start engine (TM 9-2320-366-10-1).

- (5) Check for fuel leaks under vehicle.
- (6) Raise cab (TM 9-2320-366-10-1).
- (7) Check for fuel leaks around fuel filter.
- (8) Lower cab (TM 9-2320-366-10-1).
- (9) Shut down engine (TM 9-2320-366-10-1).

End of Task.

4-15. ETHER STARTING AID REPLACEMENT

This task covers:

a. Ether Cylinder Removal	e. Ether Valve Removal
b. Ether Cylinder Installation	f. Ether Valve Installation
c. Clamp Removal	g. Follow-On Maintenance
d. Clamp Installation	

INITIAL SETUP

<p>Equipment Conditions Batteries disconnected (para 7-57). Spare tire lowered (TM 9-2320-366-10-2).</p> <p>Tools and Special Tools Goggles, Industrial (Item 15, Appendix C) Tool Kit, Genl Mech (Item 46, Appendix C) Wrench, Torque, 0-175 lb-ft (Item 58, Appendix C)</p>	<p>Materials/Parts Gasket (Item 26, Appendix G) Nut, Self-Locking (4) (Item 153, Appendix G)</p>
--	---

WARNING

Starting fluid is toxic and highly flammable. Container is pressurized. NEVER heat container and NEVER discharge starting fluid in confined areas or near open flame. Failure to comply may cause serious injury or death to personnel.

a. Ether Cylinder Removal.

- (1) Remove wingnut (1) from clamp (2).
- (2) Remove ether cylinder (3) and gasket (4) from ether valve (5). Discard gasket.
- (3) Remove ether cylinder (3) from clamp (2).
- (4) Remove cap (6) from cap retainer (7).
- (5) Install cap (6) on ether valve (5).

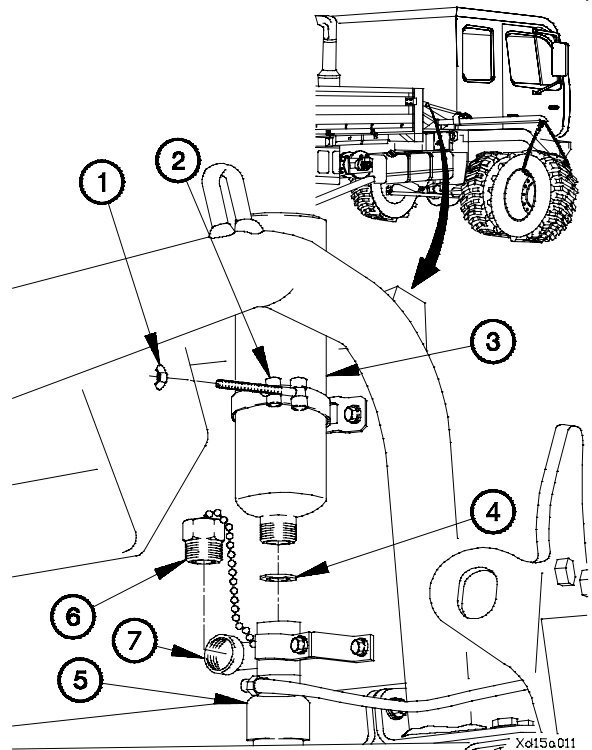

b. Ether Cylinder Installation.

- (1) Remove cap (1) from ether valve (2).
- (2) Install cap (2) on cap retainer (3).
- (3) Install gasket (4) in ether valve (2).
- (4) Position ether cylinder (5) in clamp (6).
- (5) Install ether cylinder (5) on ether valve (2).
- (6) Install wingnut (7) on clamp (6).

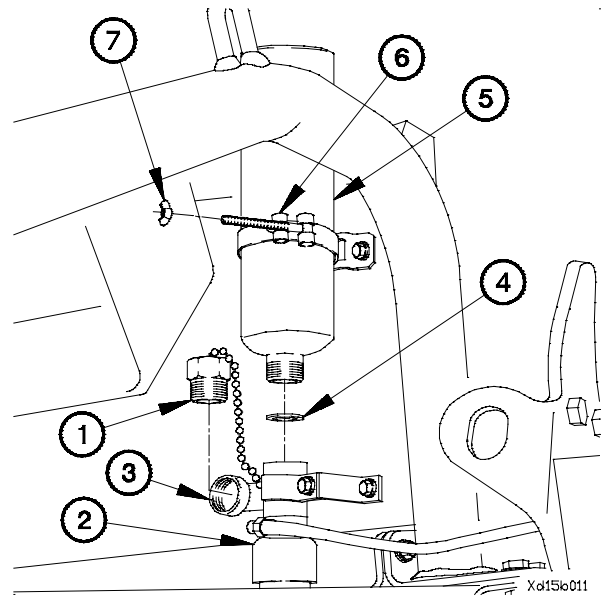

c. Clamp Removal.

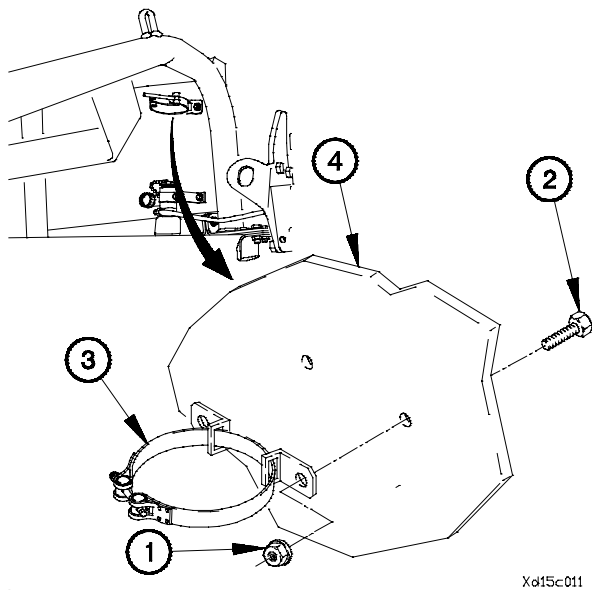

Remove two self-locking nuts (1), screws (2), and clamp (3) from spare tire retainer (4). Discard self-locking nuts.

d. Clamp Installation.

- (1) Position clamp (1) on spare tire retainer (2) with two screws (3) and self-locking nuts (4).
- (2) Tighten two self-locking nuts (4) to 25-31 lb-ft (34-42 N-m).

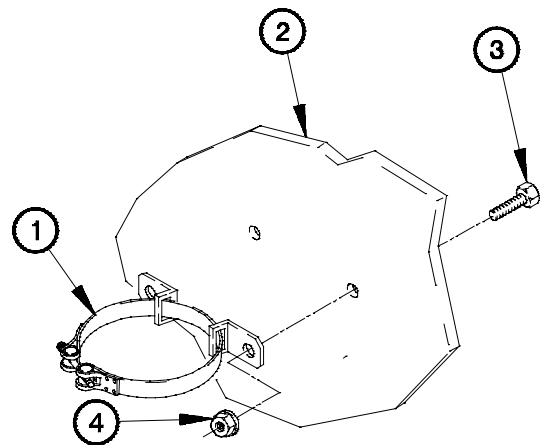

4-15. ETHER STARTING AID REPLACEMENT (CONT)

e. Ether Valve Removal.

- (1) Disconnect ether tube (1) from ether valve (2).
- (2) Disconnect ether valve electrical connector (3) from connector J93 (4).
- (3) Remove two self-locking nuts (5), screws (6), washers (7), terminal lug TL84 (8), and ether valve (2) from spare tire retainer (9). Discard self-locking nuts.

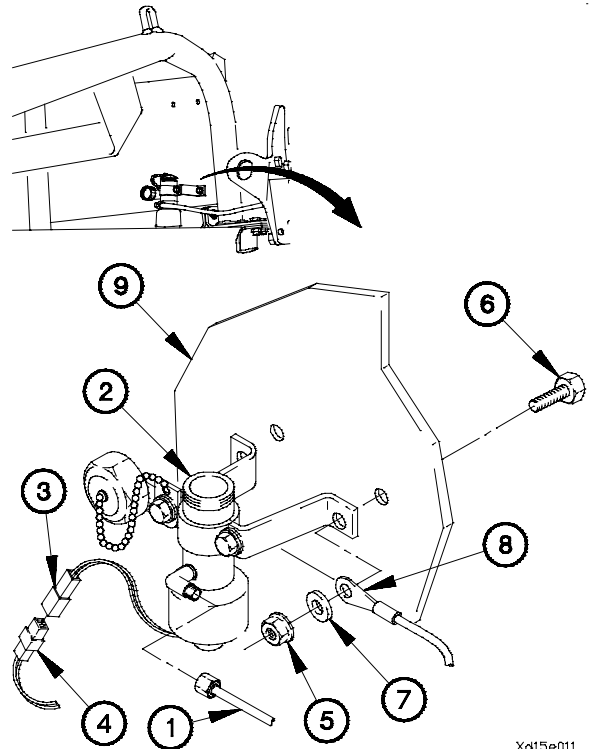

f. Ether Valve Installation.

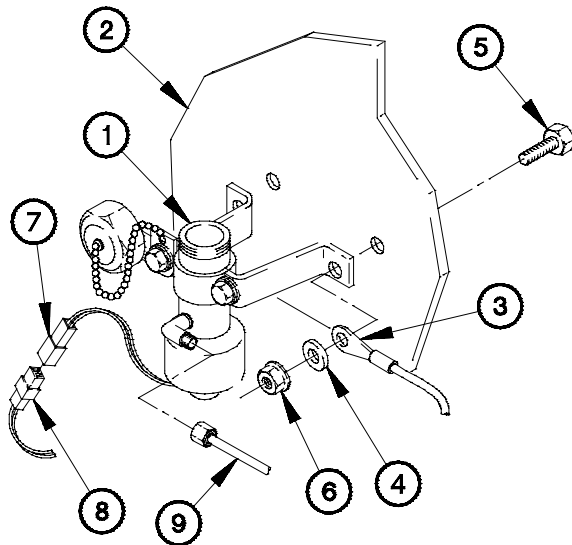

- (1) Position ether valve (1) on spare tire retainer (2), terminal lug TL84 (3), two washers (4), screws (5), and self-locking nuts (6).
- (2) Tighten self-locking nuts (6) to 25-31 lb-ft (34-42 N-m).
- (3) Connect ether valve electrical connector (7) to connector J93 (8).
- (4) Connect ether tube (9) to ether valve (1).

g. Follow-On Maintenance.

- (1) Raise spare tire (TM 9-2320-366-10-2).
- (2) Connect batteries (para 7-57).
- (3) Operate ether starting aid (TM 9-2320-366-10-2) and check for ether leaks.

End of Task.

4-16. THROTTLE POSITION SENSOR (TPS) CABLE ASSEMBLY REPLACEMENT

This task covers:

a. Removal

b. Installation

INITIAL SETUP

Equipment Conditions

Batteries disconnected (para 7-57).
Cab raised (TM 9-2320-366-10-1).

Materials/Parts

Pin, Cotter (Item 224, Appendix G)

Tools and Special Tools

Tool Kit, Genl Mech (Item 46, Appendix C)

a. Removal.

- (1) Disconnect electrical connector (1) from TPS cable assembly (2).
- (2) Remove three nuts (3), washers (4), screws (5), and TPS cable assembly (2) from bracket (6).

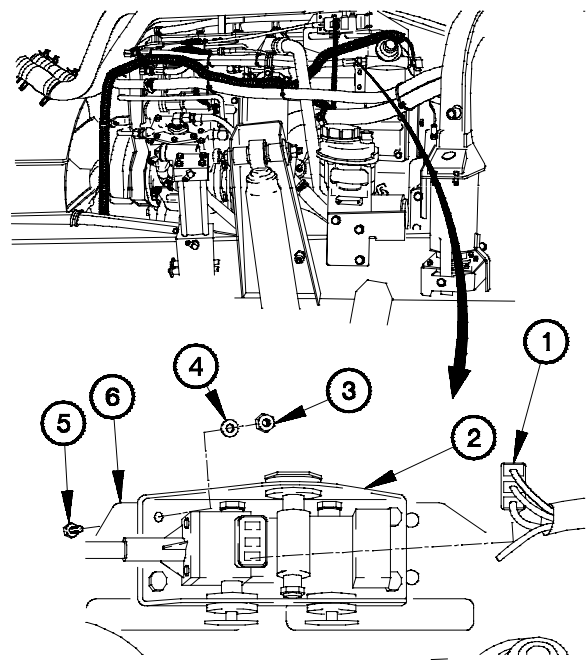

XD16R011

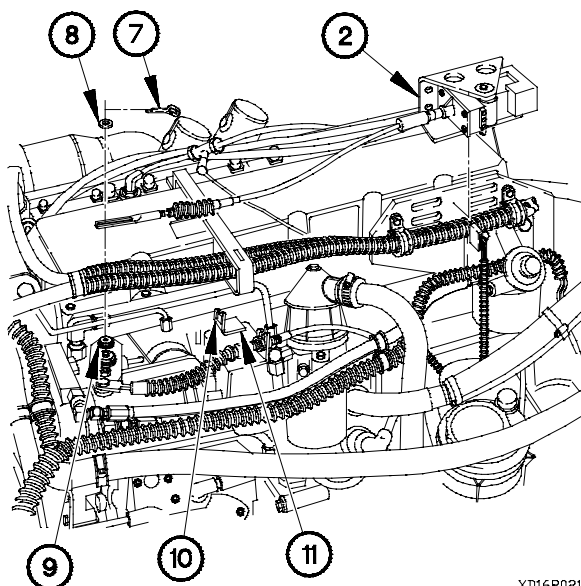

XD16R021

- (3) Remove cotter pin (7) and washer (8) from stud (9). Discard cotter pin.
- (4) Remove TPS cable assembly (2) from stud (9).
- (5) Release latch (10) on clamp (11).
- (6) Remove TPS cable assembly (2) from clamp (11).
- (7) Remove TPS cable assembly (2) from engine.

4-16. THROTTLE POSITION SENSOR (TPS) CABLE ASSEMBLY REPLACEMENT (CONT)

b. Installation.

- (1) Position TPS cable assembly (1) in clamp (2).
- (2) Close latch (3) on clamp (2).
- (3) Position TPS cable assembly (1) on stud (4).
- (4) Install washer (5) and cotter pin (6) on stud (4).

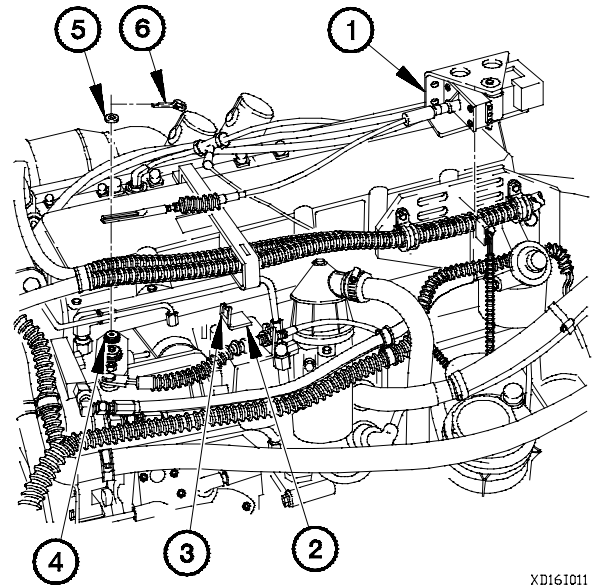

- (5) Install TPS cable assembly (1) on bracket (7) with three screws (8), washers (9) and nuts (10).
- (6) Connect electrical connector (11) to TPS cable assembly (1).
- (7) Lower cab (TM 9-2320-366-10-1).
- (8) Connect batteries (para 7-57).

NOTE

Wait until Neutral (N) indication appears in pushbutton shift selector display before positioning master power switch off.

- (9) Position master power switch on and off five times (TM 9-2320-366-10-1).

NOTE

TPS will self-adjust but vehicle will need to be operated through all gear ranges several times before correct shifting will be noticed.

- (10) Operate vehicle and check for smooth transmission shifting through all gear ranges (TM 9-2320-366-10-1).

End of Task.

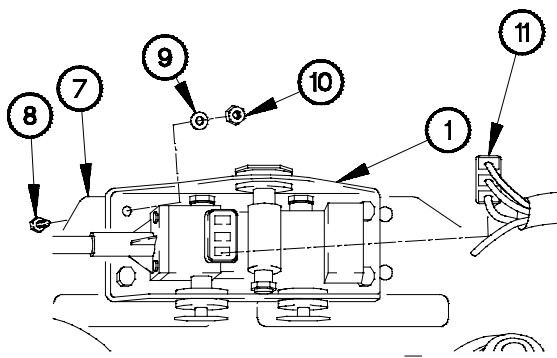

4-17. HAND THROTTLE LEVER REPLACEMENT/ADJUSTMENT	
This task covers:	
a. Removal b. Installation/Adjustment	c. Follow-On Maintenance
INITIAL SETUP	
Equipment Conditions Instrument panel assembly removed for access (para 7-15).	Tools and Special Tools Tool Kit, Genl Mech (Item 46, Appendix C) Scale, Weighing (Item 30, Appendix C)
	Materials/Parts Washer, Spring (Item 294, Appendix G)

a. Removal.

Remove nut (1), washer (2), spring washer (3), HAND THROTTLE lever (4), and friction disk (5) from dashboard (6). Discard spring washer.

b. Installation/Adjustment.

WARNING

Tab of HAND THROTTLE lever must be positioned above throttle pivot bar. Failure to comply may result in injury to personnel or damage to equipment.

- (1) Position friction disk (5), HAND THROTTLE lever (4), spring washer (3), washer (2), and nut (1) on dashboard (6).

CAUTION

HAND THROTTLE lever nut must be tightened so that 9-11 lbs (40-49 N) of force is required to change position of HAND THROTTLE lever. Failure to comply may result in damage to equipment.

- (2) Tighten nut (1) on HAND THROTTLE lever (4).

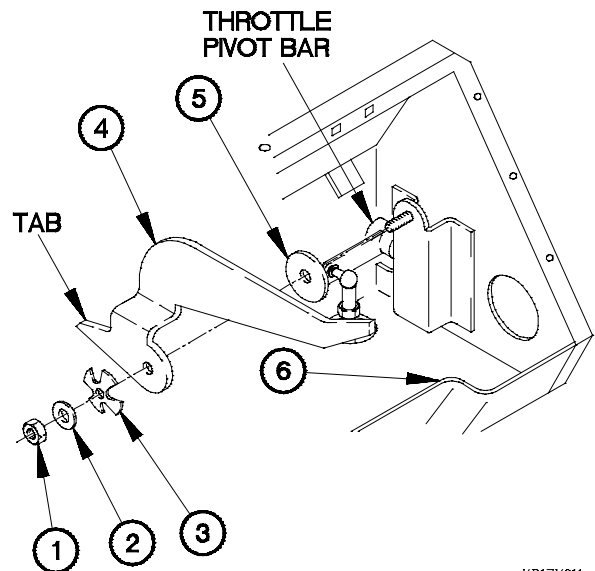

XD17X011

4-17. HAND THROTTLE LEVER REPLACEMENT/ADJUSTMENT (CONT)

c. Follow-On Maintenance.

- (1) Install instrument panel assembly (para 7-15).
- (2) Start engine (TM 9-2320-366-10-1).
- (3) Check for smooth operation of HAND THROTTLE lever.
- (4) Check high/low HAND THROTTLE lever positions (para 4-22).
- (5) Shut down engine (TM 9-2320-366-10-1).

End of Task.

4-18. THROTTLE CONTROL CABLE REPLACEMENT/ADJUSTMENT

This task covers:

- a. Removal
- b. Installation
- c. Adjustment
- d. Follow-On Maintenance

INITIAL SETUP

Equipment Conditions

Engine shut down (TM 9-2320-366-10-1).
Steering wheel removed (para 13-2).

Materials/Parts

Grease, Molybdenum Disulfide (Item 24, Appendix D)

Tools and Special Tools

Tool Kit, Genl Mech (Item 46, Appendix C)

Personnel Required

(2)

a. Removal.

- (1) Position master power switch to on (TM 9-2320-366-10-1).
- (2) Place wiper blades in the full left position (TM 9-2320-366-10-1).
- (3) Position master power switch to off (TM 9-2320-366-10-1).
- (4) Disconnect batteries (para 7-57).

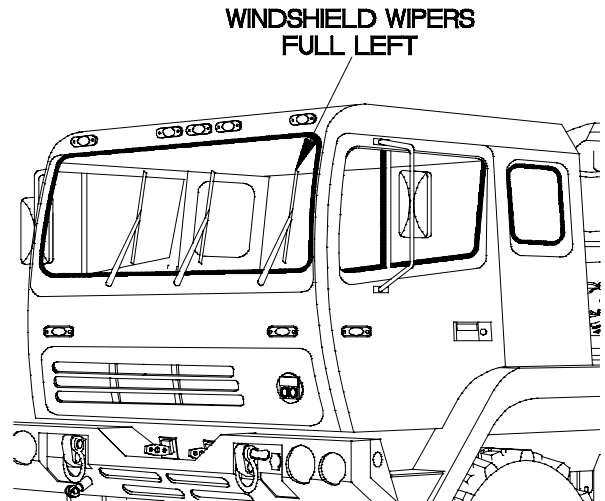

XD18A011

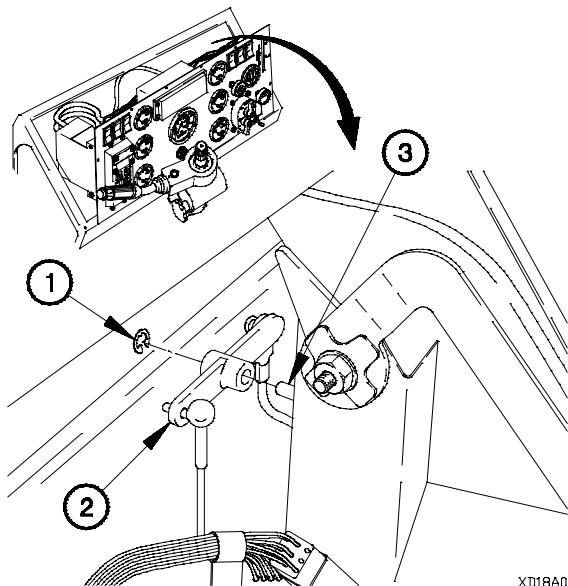

XD18A021

- (5) Remove instrument panel assembly for access (para 7-15).

WARNING

Retaining rings are under tension and can act as projectiles when released causing severe eye injury. Use care when removing retaining rings. Failure to comply may result in injury to personnel.

- (6) Remove retaining ring (1) and bellcrank (2) from stud (3).

4-18. THROTTLE CONTROL CABLE REPLACEMENT/ADJUSTMENT (CONT)

- (7) Remove clip (4) and throttle control cable (5) from stud (6).
- (8) Loosen two nuts (7) with washers (8) on throttle control cable (5).
- (9) Remove throttle control cable (5) from dashboard (9).

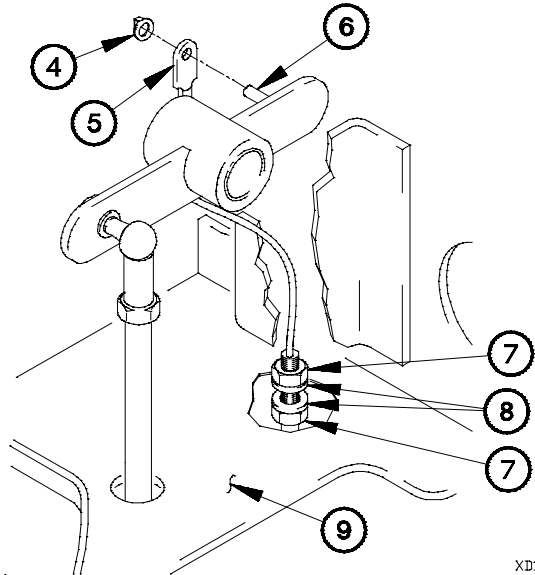

XD18A031

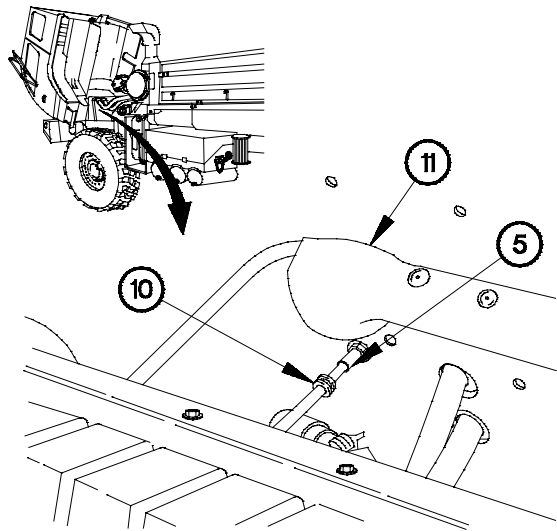

XD18A041

- (10) Raise cab (TM 9-2320-366-10-1).
- (11) Remove throttle control cable (5) and grommet (10) from cab (11).

- (12) Remove clip (12) and throttle control cable (5) from stud (13).

NOTE

Count threads showing on throttle control cable ferrule. Record this number prior to removal.

- (13) Loosen nut (14) with washers (15) on throttle control cable (5).
- (14) Remove throttle control cable (5) from bracket (16).

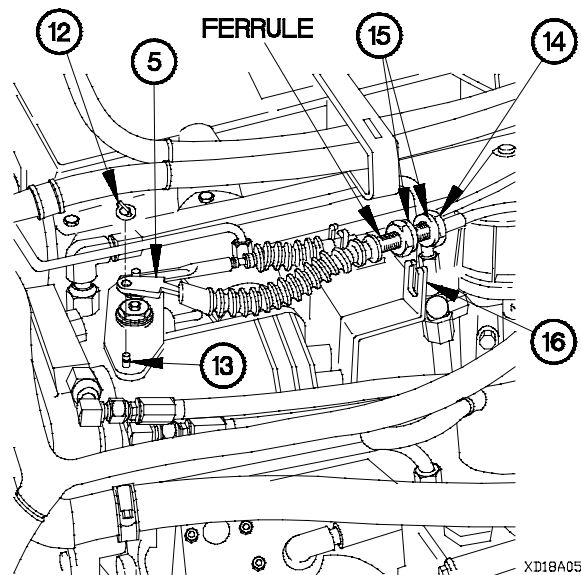

XD18A051

NOTE

- Note routing of throttle control cable prior to removal.
- Remove plastic cable ties as required.

(15) Remove throttle control cable (5) from vehicle.

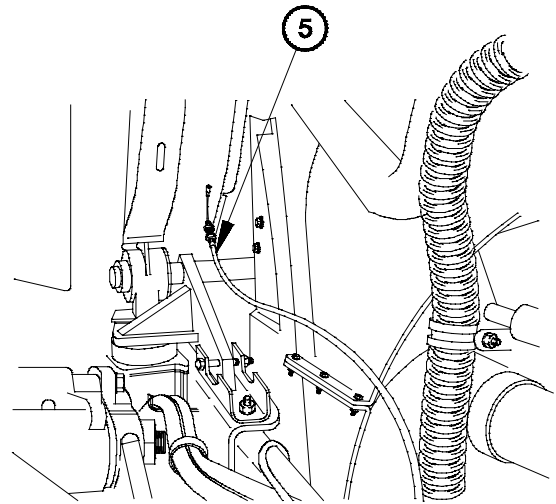

XD18A061

b. Installation.

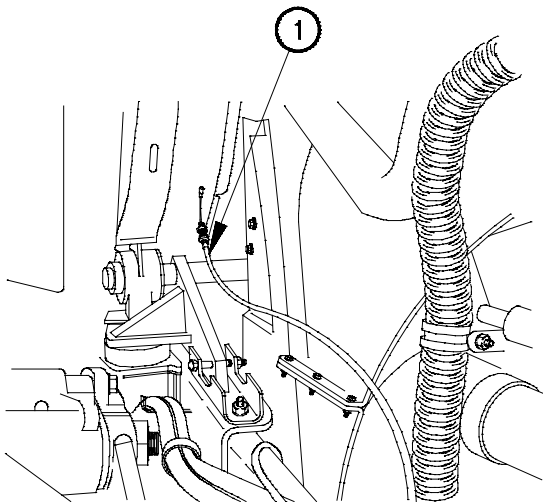

XD18B011

(1) Position throttle control cable (1) on vehicle.

- (2) Position nut (2) on throttle control cable (1) so that same number of threads are showing on ferrule as was recorded in removal.
- (3) Position throttle control cable (1) in bracket (3) with two washers (4) and nut (5).
- (4) Install throttle control cable (1) on stud (6) with clip (7).

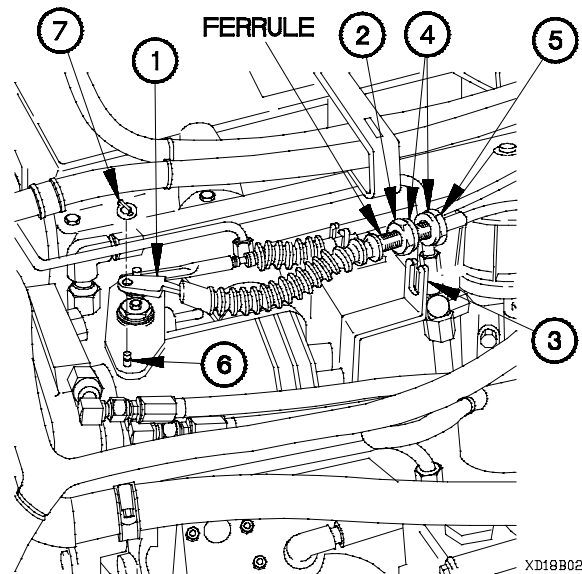

XD18B021

4-18. THROTTLE CONTROL CABLE REPLACEMENT/ADJUSTMENT (CONT)

- (5) Position grommet (8) and throttle control cable (1) in cab (9).
- (6) Lower cab (TM 9-2320-366-10-1).

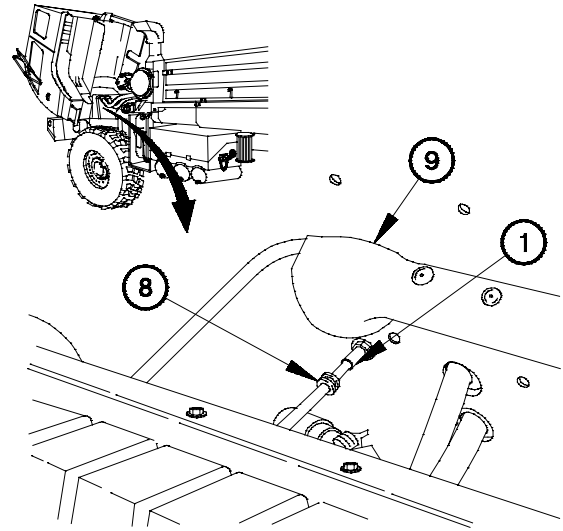

XD18B031

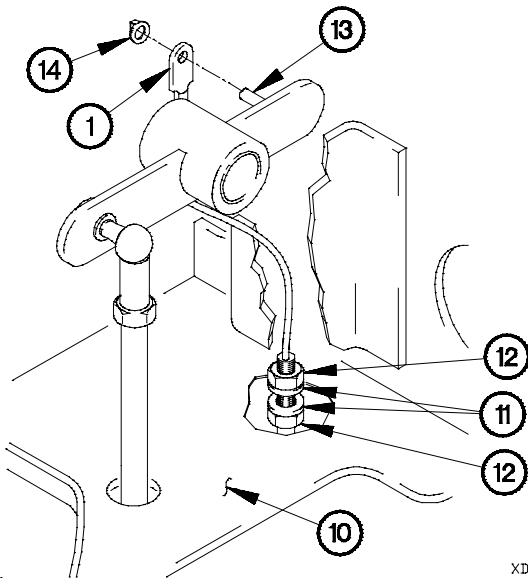

XD18B041

- (7) Position throttle control cable (1) in dashboard (10) with two washers (11) and nuts (12).
- (8) Install throttle control cable (1) on stud (13) with clip (14).

- (9) Apply grease to stud (15).

WARNING

Retaining rings are under tension and can act as projectiles when released causing severe eye injury. Use care when installing retaining rings. Failure to comply may result in injury to personnel.

- (10) Install bellcrank (16) on stud (15) with retaining ring (17).

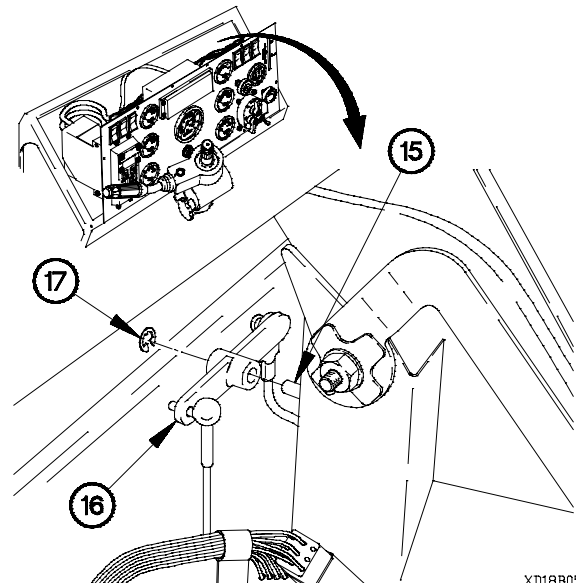

XD18B051

c. Adjustment.

- (1) Raise cab (TM 9-2320-366-10-1).

CAUTION

Ensure governor linkage rests against low idle stop with throttle control cable installed. Failure to comply may result in damage to equipment.

NOTE

Perform steps (2) and (3) if governor linkage does not contact low idle stop with throttle control cable installed.

- (2) Loosen nut (1) on throttle control cable (2) until governor linkage (3) contacts low idle stop (4).
 (3) Tighten nut (5) on throttle control cable (2).

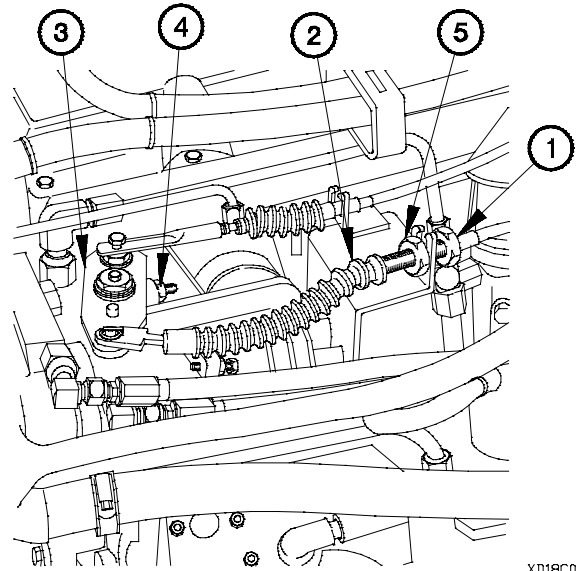

XD18C011

WARNING

Use extreme care when opening cab door with cab raised. Failure to comply may result in injury to personnel or damage to equipment.

CAUTION

Ensure governor linkage contacts high idle stop with accelerator pedal fully depressed. Failure to comply may result in damage to equipment.

NOTE

Steps (4) through (7) require the aid of an assistant.

- (4) Depress accelerator pedal (6) to cab floor (7).

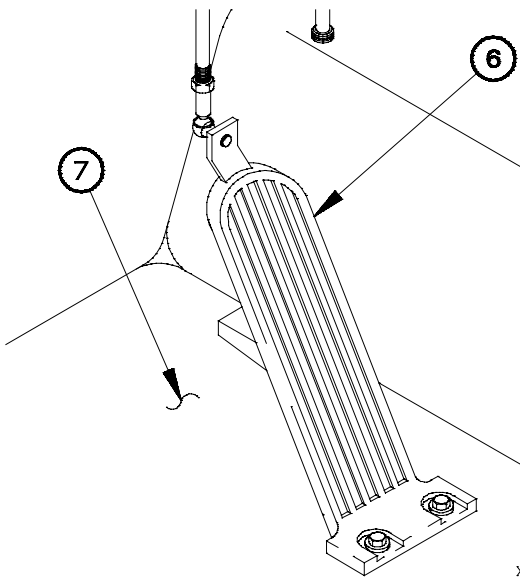

XD18C021

4-18. THROTTLE CONTROL CABLE REPLACEMENT/ADJUSTMENT (CONT)

(5) Observe movement of governor linkage (3) to high idle stop (8).

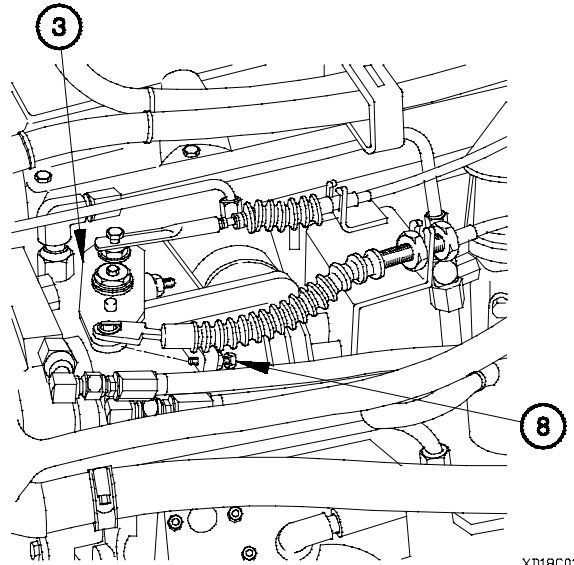

XD18C031

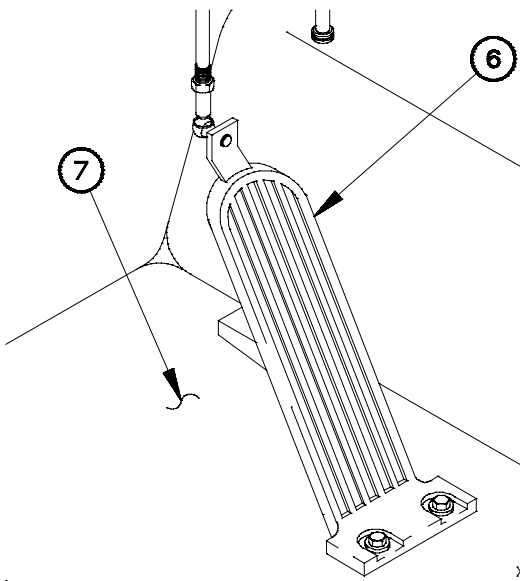

XD18C041

(6) Release accelerator pedal (6) from cab floor (7).

(7) Observe movement of governor linkage (3) from high idle stop (8) to low idle stop (4).

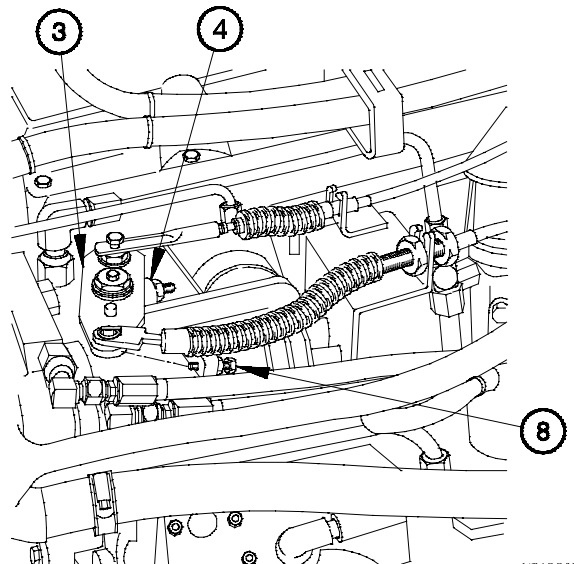

XD18C051

- (8) Loosen nut (9) on throttle control cable (2).
- (9) Tighten nut (10) on throttle control cable (2).
- (10) Perform steps (4) through (9) until freeplay is removed from throttle control cable (2).

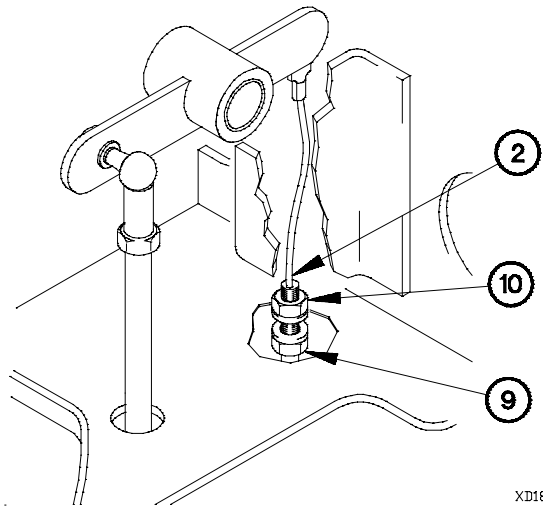

XD18C061

d. Follow-On Maintenance.

- (1) Lower cab (TM 9-2320-366-10-1).
- (2) Install instrument panel assembly (para 7-15).
- (3) Operate windshield wipers, position wipers stowed (TM 9-2320-366-10-1).
- (4) Start engine, check accelerator for smooth operation (TM 9-2320-366-10-1).
- (5) Check high/low HAND THROTTLE lever positions (para 4-22).
- (6) Shut down engine (TM 9-2320-366-10-1).

End of Task.

4-19. THROTTLE CONTROL THREADED ROD REPLACEMENT	
This task covers:	
a. Removal b. Installation	c. Follow-On Maintenance
INITIAL SETUP	
Equipment Conditions Instrument panel assembly removed for access (para 7-15).	Materials/Parts Grease, Molybdenum Disulfide (Item 24, Appendix D)
Tools and Special Tools Tool Kit, Genl Mech (Item 46, Appendix C)	

a. Removal.

- (1) Remove clip ring (1) from ball seat (2).
- (2) Remove ball seat (2) and threaded rod (3) from ball stud (4).

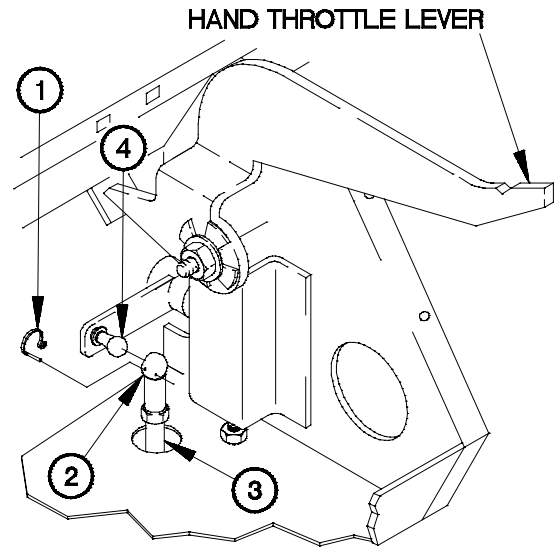

XD19R011

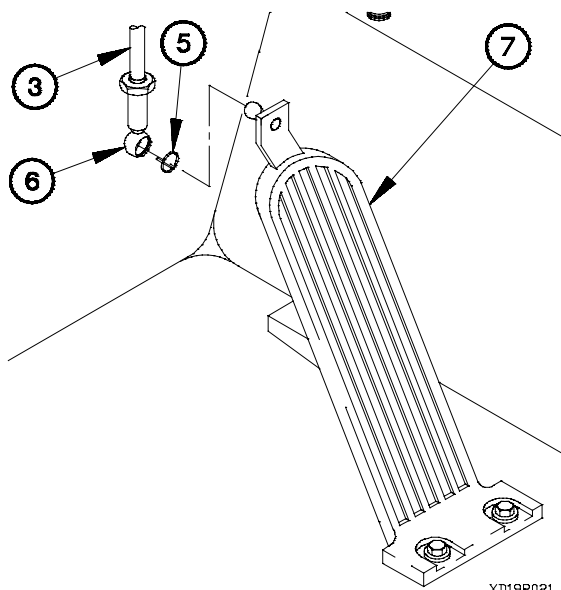

XD19R021

- (3) Remove clip ring (5) from ball seat (6).
- (4) Remove ball seat (6) and threaded rod (3) from accelerator pedal (7).

- (5) Loosen two jam nuts (8) behind ball seats (2 and 6).
- (6) Remove ball seats (2 and 6) and two jam nuts (8) from threaded rod (3).

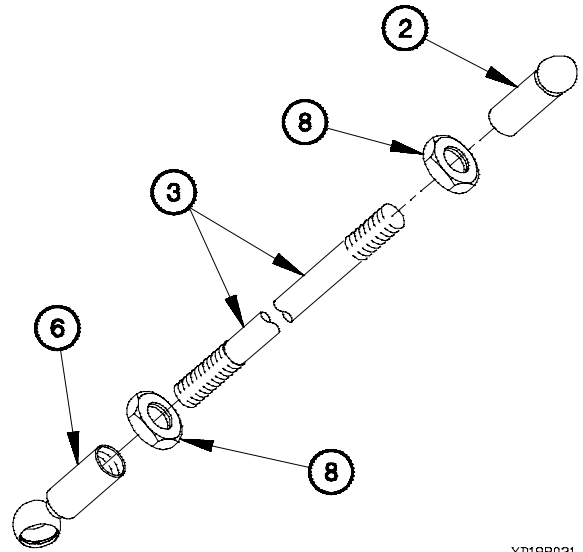

XD19R031

b. Installation.

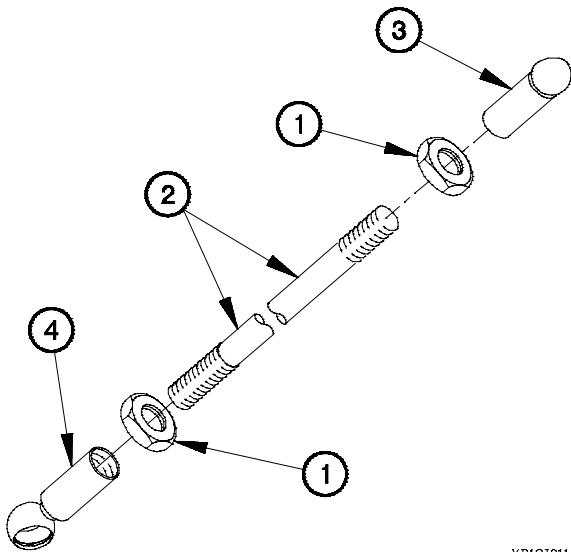

XD19I011

- (1) Install two jam nuts (1) to bottom of threads on threaded rod (2).
- (2) Install ball seats (3 and 4) on threaded rod (2) until ball seats contact two jam nuts (1).
- (3) Tighten two jam nuts (1) against ball seats (3 and 4).

- (4) Apply grease to inside of ball seat (3).
- (5) Install ball seat (3) in accelerator pedal (5).
- (6) Install clip ring (6) on ball seat (3).

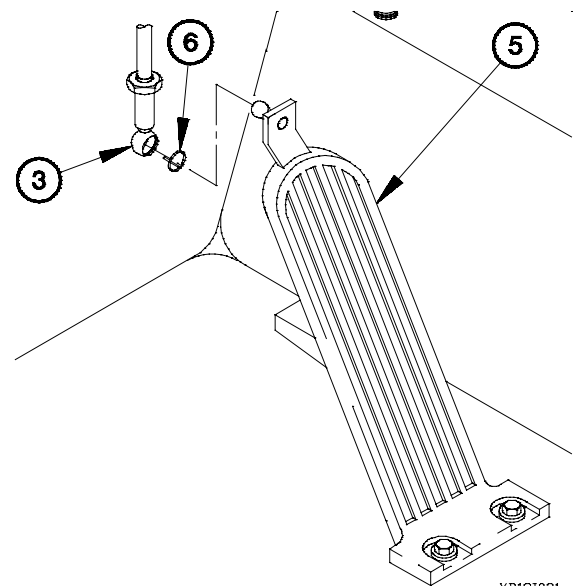

XD19I021

4-19. THROTTLE CONTROL THREADED ROD REPLACEMENT (CONT)

- (7) Apply grease to inside of ball seat (4).
- (8) Install ball seat (4) on ball stud (7).
- (9) Install clip ring (8) on ball seat (4).

c. Follow-On Maintenance.

- (1) Install instrument panel assembly (para 7-15).
- (2) Start engine (TM 9-2320-366-10-1).
- (3) Depress accelerator pedal and check for smooth operation.
- (4) Check high/low HAND THROTTLE lever positions (para 4-22).
- (5) Shut down engine (TM 9-2320-366-10-1).

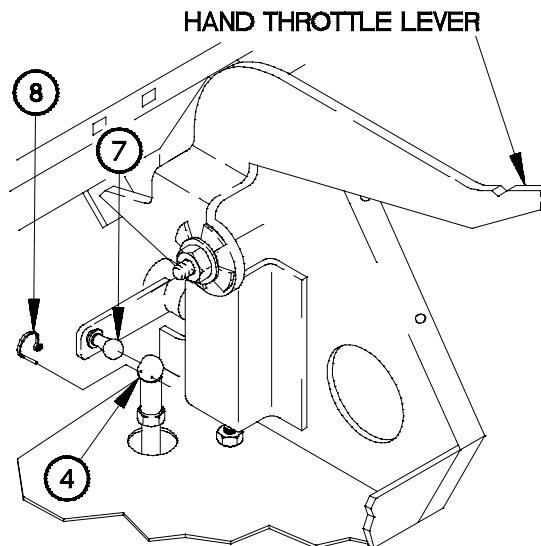

XD191031

End of Task.

4-20. THROTTLE CONTROL LEVER REPLACEMENT

This task covers:

- a. Removal
- b. Installation
- c. Follow-On Maintenance

INITIAL SETUP

Equipment Conditions

Steering wheel removed (para 13-2).

Materials/Parts

Grease, Molybdenum Disulfide (Item 24, Appendix D)
 Washer, Spring (Item 288, Appendix G)

Tools and Special Tools

Tool Kit, Genl Mech (Item 46, Appendix C)

a. Removal.

- (1) Position master power switch to on (TM 9-2320-366-10-1).
- (2) Place wiper blades in the full left position (TM 9-2320-366-10-1).
- (3) Position master power switch to off (TM 9-2320-366-10-1).
- (4) Disconnect batteries (para 7-57).
- (5) Remove instrument panel assembly for access (para 7-15).

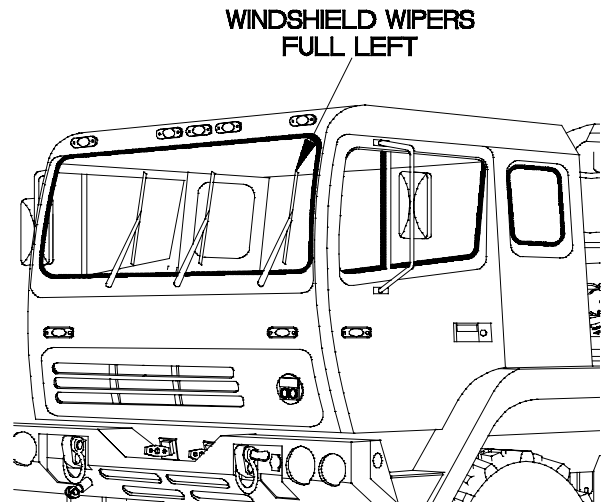

XD20R011

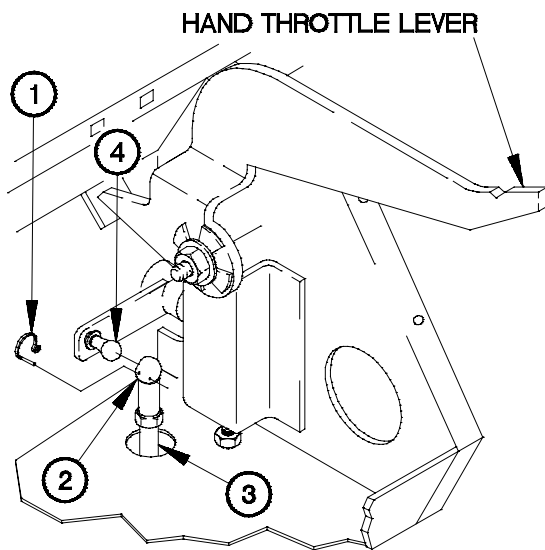

XD20R021

- (6) Remove clip ring (1) from ball seat (2).
- (7) Remove ball seat (2) with threaded rod (3) from ball stud (4).

4-20. THROTTLE CONTROL LEVER REPLACEMENT (CONT)

WARNING

Retaining rings are under tension and can act as projectiles when released causing severe eye injury. Use care when removing retaining rings. Failure to comply may result in injury to personnel.

- (8) Remove retaining ring (5) and lever (6) from lever stud (7).
- (9) Remove bushing (8) from lever stud (7).

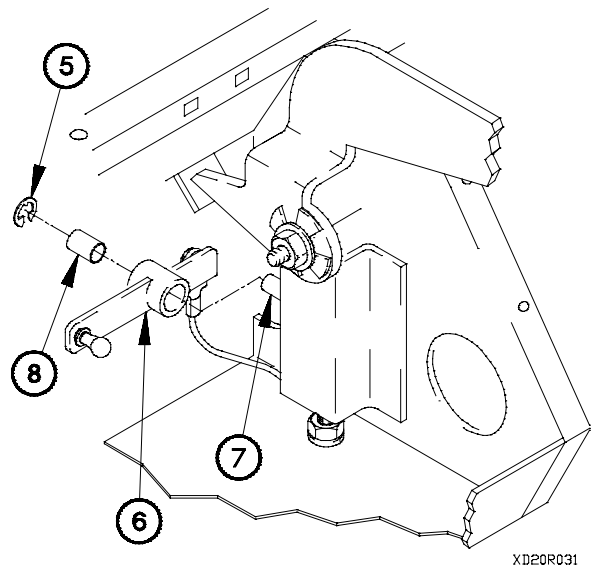

XD20R031

- (10) Remove clip (9) and throttle control cable (10) from stud (11).
- (11) Remove nut (12), spring washer (13), and ball stud (4) from lever (6). Discard spring washer.

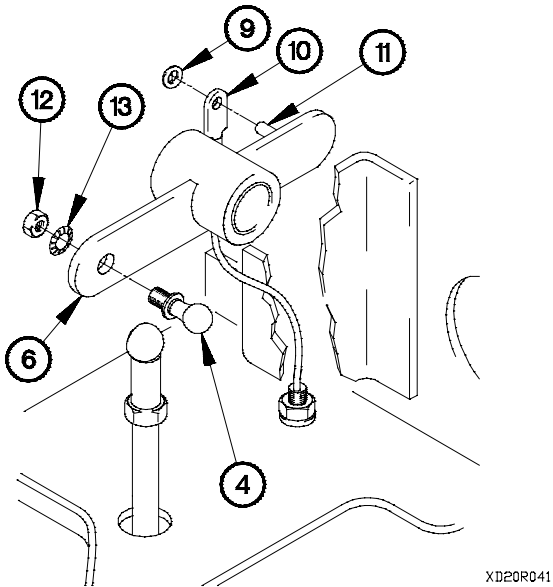

XD20R041

b. Installation.

- (1) Install ball stud (1) on lever (2) with spring washer (3) and nut (4).
- (2) Install throttle control cable (5) on stud (6) with clip (7).

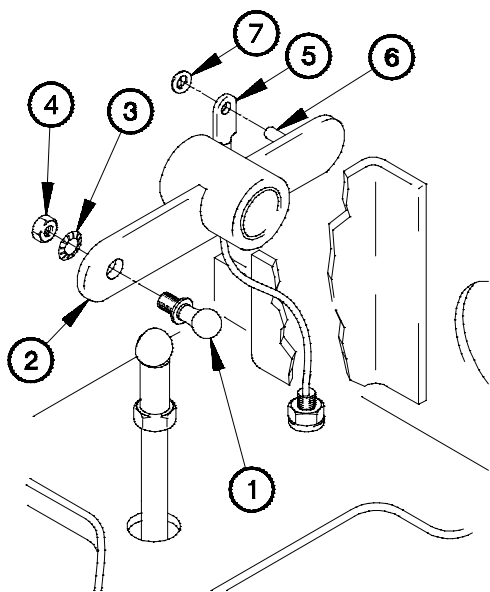

XD20I011

- (3) Apply grease to bushing (8) and lever stud (9).

WARNING

Retaining rings are under tension and can act as projectiles when released causing severe eye injury. Use care when removing retaining rings. Failure to comply may result in injury to personnel.

- (4) Install bushing (8) and lever (2) on lever stud (9) with retaining ring (10).

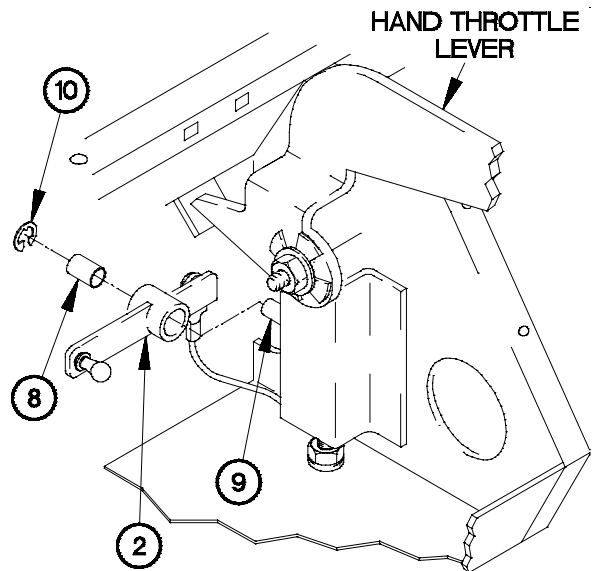

XD201021

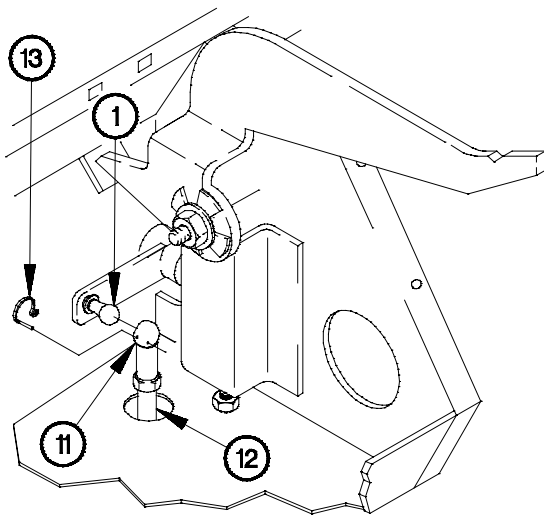

XD201031

- (5) Apply grease to ball stud (1).
- (6) Install ball seat (11) with threaded rod (12) on ball stud (1).
- (7) Install clip ring (13) on ball seat (11).

c. Follow-On Maintenance.

- (1) Install instrument panel assembly (para 7-15).
- (2) Start engine (TM 9-2320-366-10-1).
- (3) Position windshield wiper control to off (TM 9-2320-366-10-1).
- (4) Depress accelerator pedal and check for smooth operation.
- (5) Check high/low HAND THROTTLE lever positions (para 4-22).
- (6) Shut down engine (TM 9-2320-366-10-1).

End of Task.

4-21. ACCELERATOR PEDAL REPLACEMENT	
This task covers:	
a. Removal b. Installation	c. Follow-On Maintenance
INITIAL SETUP	
Equipment Conditions Engine shut down (TM 9-2320-366-10-1).	Materials/Parts Grease, Molybdenum Disulfide (Item 24, Appendix D)
Tools and Special Tools Tool Kit, Genl Mech (Item 46, Appendix C) Wrench, Torque, 0-200 lb-in. (Item 59, Appendix C) Socket Set, Socket Wrench (Item 35, Appendix C)	

a. Removal.

- (1) Remove clip ring (1) from ball seat (2).
- (2) Remove ball seat (2) and threaded rod (3) from ball stud (4).
- (3) Remove two screws (6), washers (7), and accelerator pedal (5) from cab floor (8).

b. Installation.

- (1) Position accelerator pedal (5) on cab floor (8) with two washers (7) and screws (6).
- (2) Tighten two screws (6) to 72-84 lb-in. (8-10 N-m).
- (3) Apply grease to inside of ball seat (2).
- (4) Install ball seat (2) and threaded rod (3) on ball stud (4).
- (5) Install clip ring (1) on ball seat (2).

c. Follow-On Maintenance.

- (1) Start engine (TM 9-2320-366-10-1).
- (2) Depress accelerator pedal and check for smooth operation.
- (3) Shut down engine (TM 9-2320-366-10-1).

End of Task.

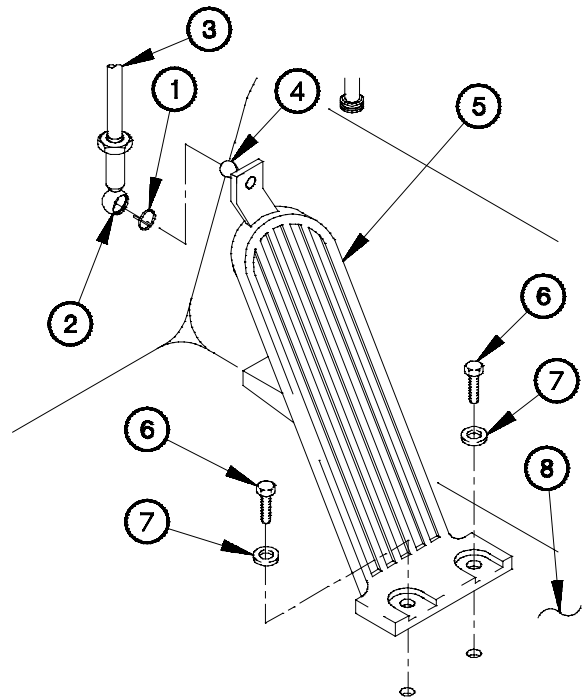

XD21X011

4-22. CHECKING AND STENCILING HIGH/LOW HAND THROTTLE POSITIONS

This task covers:

- a. Checking High/Low Hand Throttle Positions
- b. Stenciling High/Low Hand Throttle Positions

Equipment Conditions

Engine shut down (TM 9-2320-366-10-1).

Tools and Special Tools

STE/ICE-R (Item 41, Appendix C)
 Gloves, Rubber (Item 13, Appendix C)
 Respirator, Air Filter (Item 29, Appendix C)

Materials/Parts

Rubber Stamp Set, Fixed Type (Item 53, Appendix D)
 Polyurethane Coating (Item 48, Appendix D)
 Ink, Marking Stencil (Item 26, Appendix D)
 Inking Pad, Rubber Stamp (Item 27, Appendix D)

References

TM 9-4910-571-12&P
 TB 43-0209

a. Checking High/Low Hand Throttle Positions.

- (1) Connect STE/ICE-R to DCA connector (1).
- (2) Start engine (TM 9-2320-366-10-1).

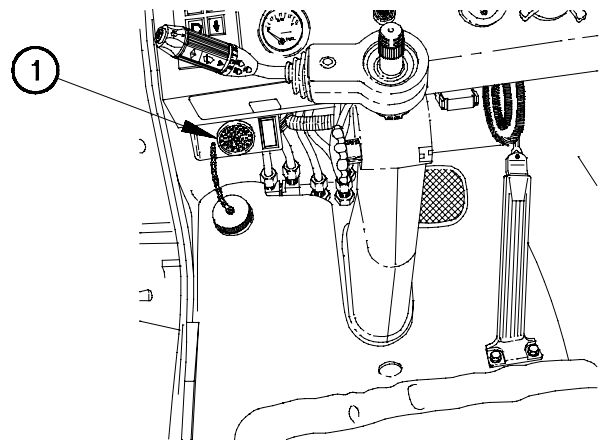

STEERING WHEEL
 REMOVED FOR
 CLARITY

XD22A01A

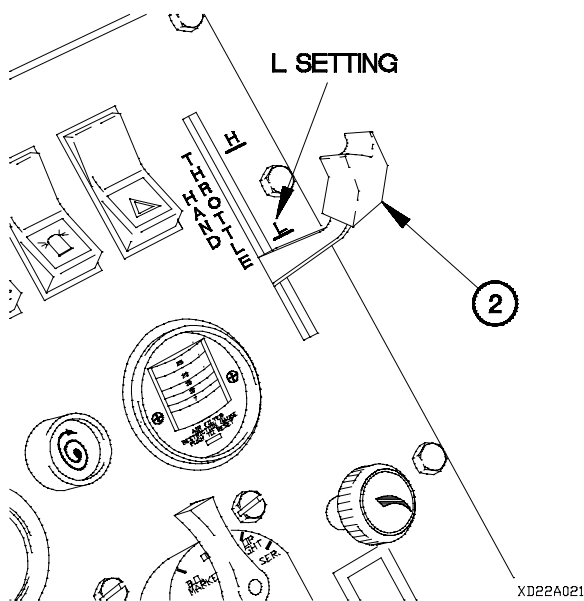

XD22A021

- (3) Position HAND THROTTLE lever (2) so that upper edge of lever is even with line below L setting.

NOTE

Acceptable engine RPM with HAND THROTTLE lever at L setting is 1250-1450 RPM.

- (4) Perform STE/ICE-R test #10.

4-22. CHECKING AND STENCILING HIGH/LOW HAND THROTTLE POSITIONS (CONT)

- (5) Position HAND THROTTLE lever (2) so that upper edge of lever is even with line below H setting.

NOTE

Acceptable engine RPM with HAND THROTTLE lever at H setting is 2000-2200 RPM.

- (6) Perform STE/ICE-R test #10.
- (7) Perform subparagraph **b. Stenciling High/Low Hand Throttle Positions** if engine RPM results from steps (4) and (6) are not within acceptable limits.

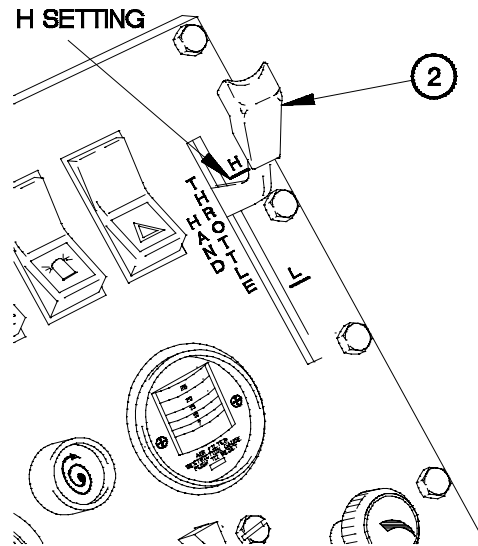

XD22A031

b. Stenciling High/Low Hand Throttle Positions.

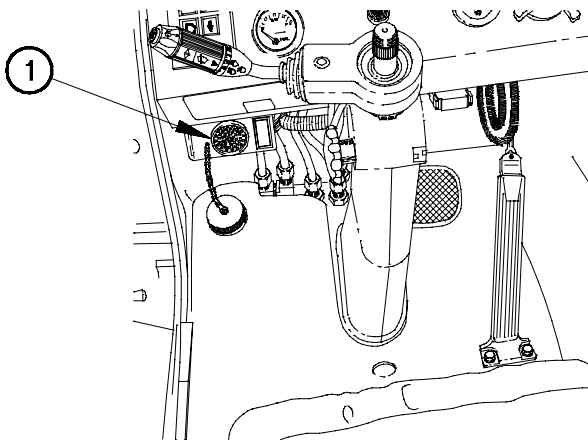

STEERING WHEEL
REMOVED FOR
CLARITY

XD22B01A

- (1) Paint over old high and low HAND THROTTLE lever position markings (TB 43-0209).
- (2) Connect STE/ICE-R to DCA connector (1).
- (3) Start engine (TM 9-2320-366-10-1).
- (4) Perform STE/ICE-R test #10.

- (5) Raise engine RPM to 1350 using HAND THROTTLE lever (2).
- (6) Stencil a line even with top edge of HAND THROTTLE lever (2).

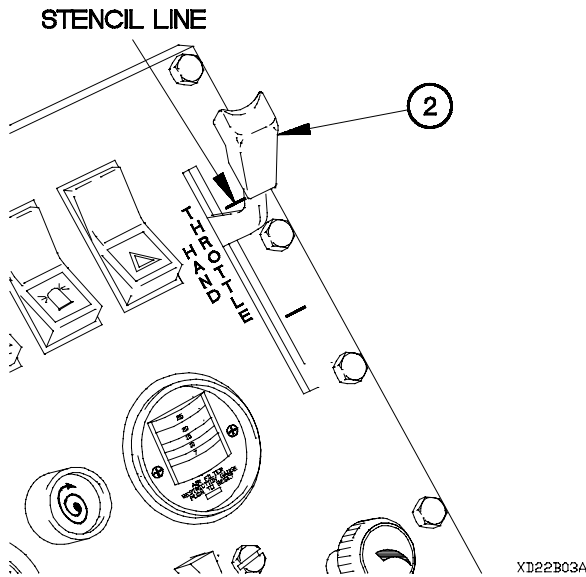
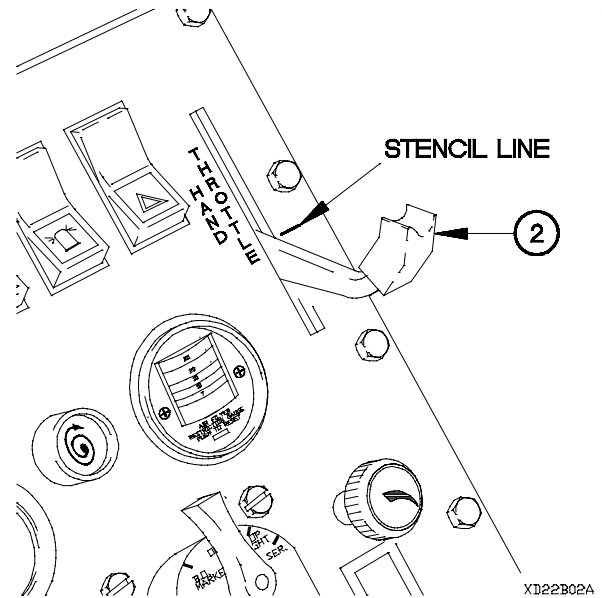

- (7) Raise engine RPM to 2100 using HAND THROTTLE LEVER (2).
- (8) Stencil a line even with top edge of HAND THROTTLE lever (2).
- (9) Lower engine RPM to idle using HAND THROTTLE lever (2).
- (10) Shut down engine (TM 9-2320-366-10-1).

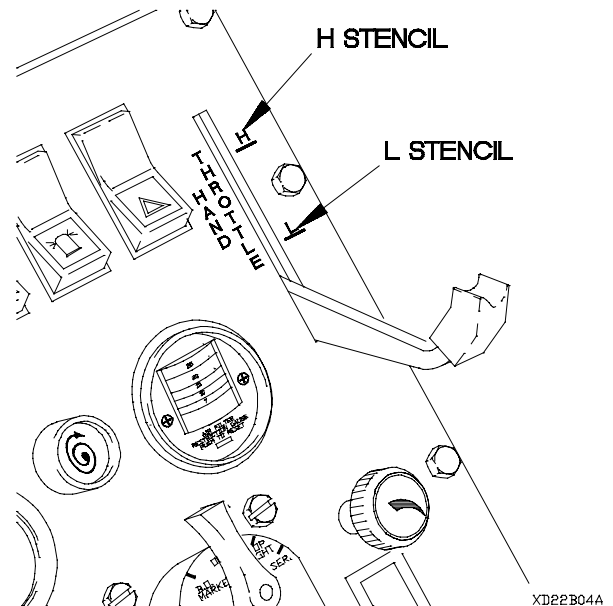

- (11) Stencil L above lower line.
- (12) Stencil H above upper line.

End of Task.

CHAPTER 5 EXHAUST SYSTEM MAINTENANCE

RESTRICTED MAINTENANCE NOTICE

Units not authorized SC 4910-95-CL-A72 (SHOP EQUIPMENT, COMMON NO. 2) in their T.O.E. may be unable to perform some of the maintenance tasks described in this chapter. If the required tools are not authorized, the equipment must be submitted to DS Maintenance for repair.

Section I. INTRODUCTION	5-1
5-1. INTRODUCTION	5-1
Section II. MAINTENANCE PROCEDURES	5-2
5-2. MUFFLER AND EXHAUST HEAT SHIELDS REPLACEMENT	5-2
5-3. EXHAUST PIPE REPLACEMENT	5-8
5-4. TAILPIPE REPLACEMENT	5-13

Section I. INTRODUCTION

5-1. INTRODUCTION

This chapter contains maintenance instructions for replacing exhaust system components authorized by the Maintenance Allocation Chart (MAC) at the Unit Maintenance level.

Section II. MAINTENANCE PROCEDURES

5-2. MUFFLER AND EXHAUST HEAT SHIELDS REPLACEMENT	
This task covers:	
<ul style="list-style-type: none"> a. Removal b. Installation 	<ul style="list-style-type: none"> c. Follow-On Maintenance
INITIAL SETUP	
<p>Equipment Conditions Engine shut down (TM 9-2320-366-10-1).</p> <p>Tools and Special Tools Goggles, Industrial (Item 15, Appendix C) Tool Kit, Genl Mech (Item 46, Appendix C) Drill, Electric, Portable (Item 7, Appendix C) Drill Set, Twist (Item 6, Appendix C) Drill, Twist (Item 8, Appendix C) Wrench, Torque, 0-200 lb-in. (Item 59, Appendix C) Wrench, Torque, 0-175 lb-ft (Item 58, Appendix C) Socket Set, Socket Wrench (Item 36, Appendix C)</p>	<p>Materials/Parts Nut, Self-Locking (2) (Item 157, Appendix G) Nut, Self-Locking (4) (Item 154, Appendix G) Nut, Self-Locking (Item 156, Appendix G) Nut, Self-Locking (2) (Item 129, Appendix G) Nut, Self-Locking (2) (Item 168, Appendix G) Washer, Flat (4) (Item 280, Appendix G) Screw, Cap (2) (Item 261, Appendix G) Grommet, Nonmetallic (6) (Item 52, Appendix G)</p> <p>Personnel Required (2)</p>

WARNING

- **Wear appropriate eye protection when working under vehicle due to the possibility of falling debris. Failure to comply may result in injury to personnel.**
- **Ensure exhaust system is cool before performing maintenance. Failure to comply may result in injury to personnel.**
- **Do not operate MTV vehicle with muffler removed. Toxic exhaust fumes may enter cab, resulting in serious injury or death to personnel.**

a. Removal.

- (1) Remove self-locking nut (1) from clamp (2). Discard self-locking nut.
- (2) Disconnect exhaust pipe (3) from muffler (4).

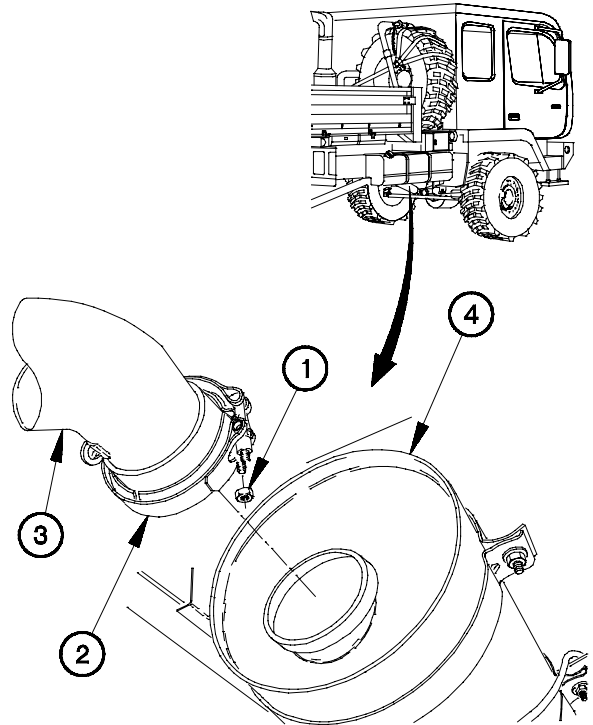

XE02R01-

- (3) Remove self-locking nut (5) from clamp (6). Discard self-locking nut.
- (4) Disconnect tail pipe (7) from muffler (4).

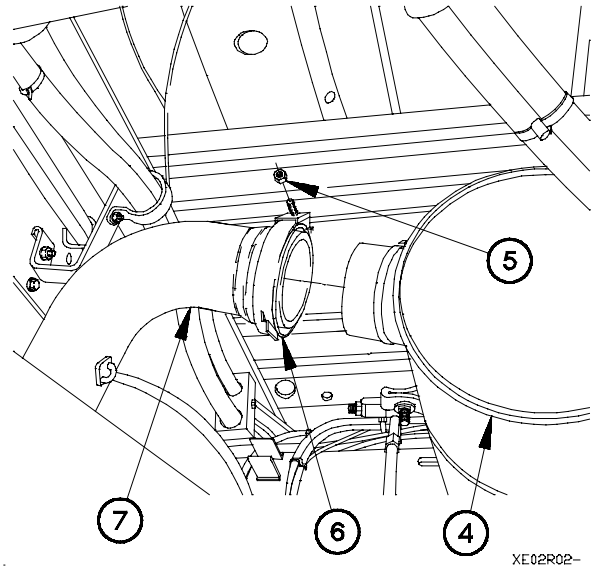

NOTE

Vehicle serial numbers 0001 through 3091, except M1088 and M1089, were originally equipped with different mounting hardware than vehicle serial numbers 3092 and higher serial numbers. Perform steps (5) through (7) on vehicle serial numbers 0001 through 3091, except M1088 and M1089, that have not previously had a muffler replaced.

- (5) Remove two screws (8) and washers (9) from muffler straps (10).

NOTE

Step (6) requires the aid of an assistant.

- (6) Remove muffler (4) from two muffler support brackets (11).

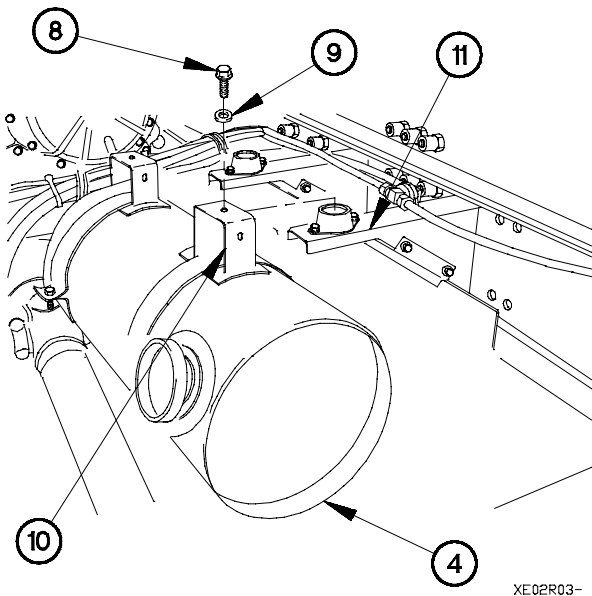

5-2. MUFFLER AND EXHAUST HEAT SHIELDS REPLACEMENT (CONT)

(7) Remove four nuts (12), washers (13), screws (14), washers (15), and two resilient mounts (16) from muffler support brackets (11). Discard nuts, washers, screws, and resilient mounts.

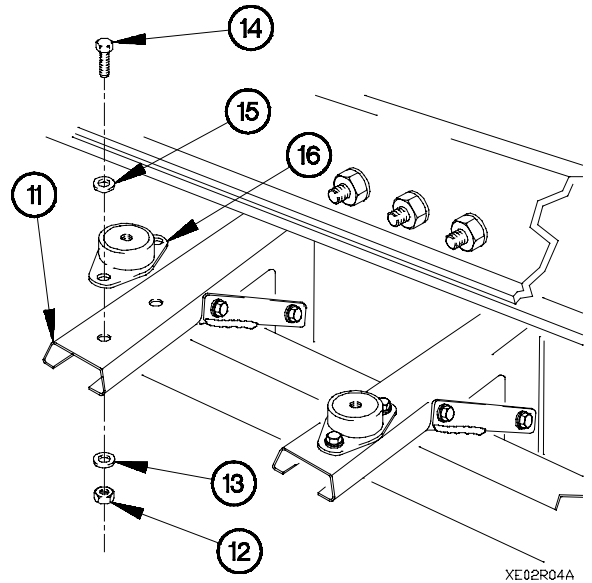

XE02R04A

NOTE

- Perform step (8) on M1088/M1089, vehicle serial numbers 3092 and higher, and vehicles that have previously had a muffler replaced.
- Step (8) requires the aid of an assistant.

(8) Remove two self-locking nuts (17), washers (18), rubber grommets (19), screws (20), washers (21), four rubber grommets (22), and muffler (4) from muffler support brackets (11). Discard self-locking nuts and rubber grommets.

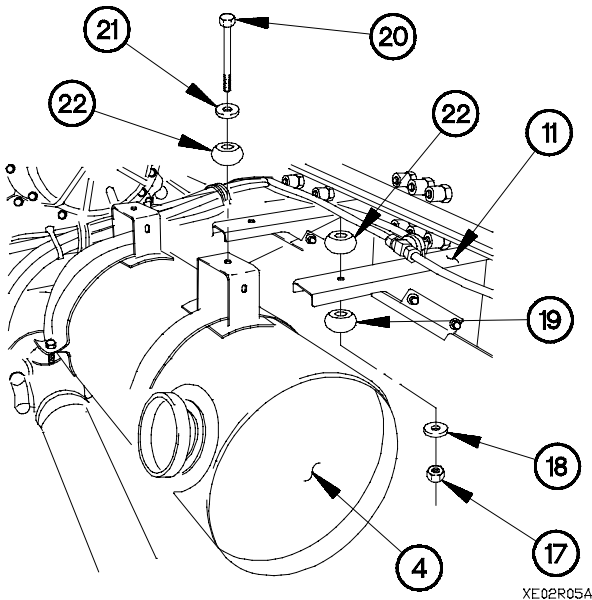

XE02R05A

- (9) Remove four self-locking nuts (23), screws (24), and exhaust heat shield (25) from two muffler support brackets (11). Discard self-locking nuts.

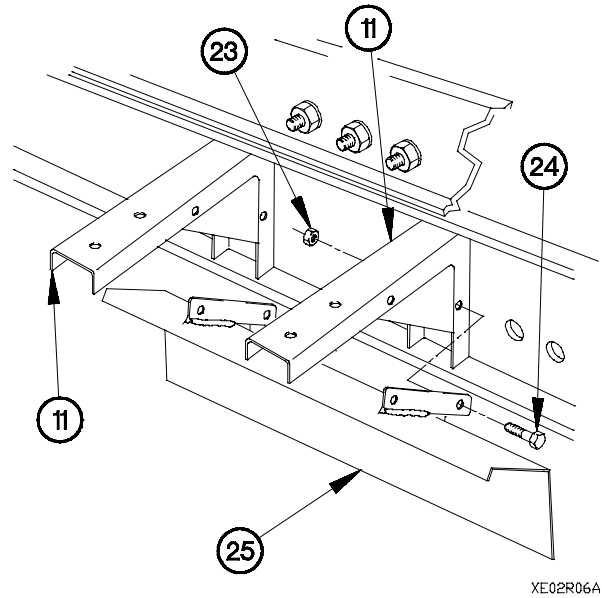

XE02R06A

- (10) Remove two self-locking nuts (26), screws (27), and muffler straps (28) from muffler (4). Discard self-locking nuts.

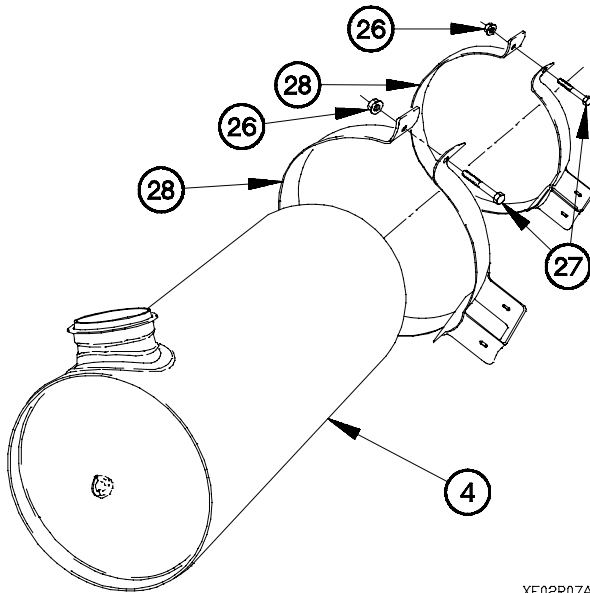

XE02R07A

b. Installation.

NOTE

Perform steps (1) through (5) on vehicle serial numbers 0001 through 3091, except M1088 and M1089, that have not previously had a muffler replaced.

- (1) Scribe a line on muffler support bracket (1) 9.7 in. (24.6 cm) out from right frame rail (2).
- (2) Scribe a line on muffler support bracket (1) 1.25 in. (3.2 cm) from front edge of front muffler support bracket.
- (3) Drill a pilot hole at intersection of lines scribed in steps (1) and (2).
- (4) Enlarge pilot hole to 16.5 mm.
- (5) Perform steps (1) through (4) on rear muffler support bracket.

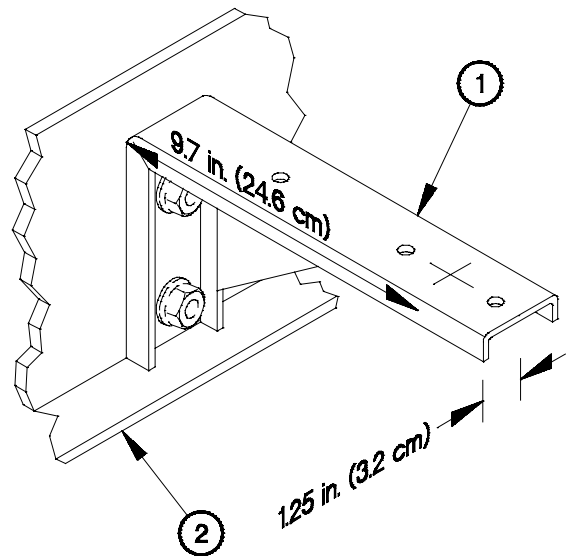

XE02I011

5-2. MUFFLER AND EXHAUST HEAT SHIELDS REPLACEMENT (CONT)

(6) Position two muffler straps (3) on muffler (4) with two screws (5) and self-locking nuts (6).

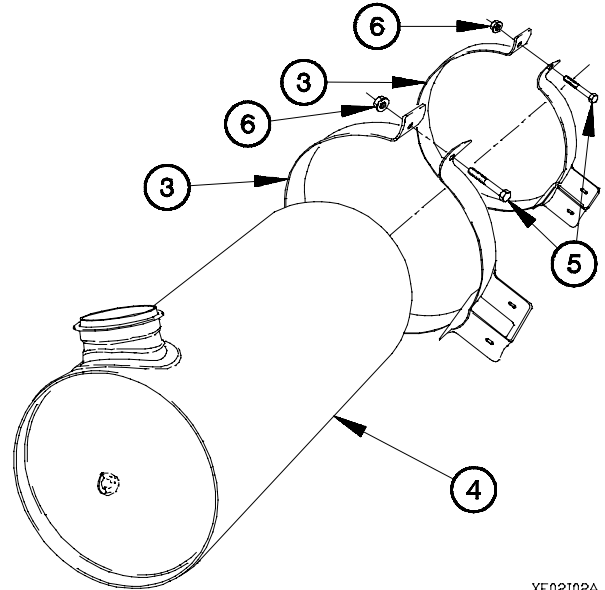

XE02102A

(7) Position exhaust heat shield (7) on two muffler support brackets (2) with four screws (8) and self-locking nuts (9).

(8) Tighten four self-locking nuts (9) to 25-29 lb-ft (34-39 N-m).

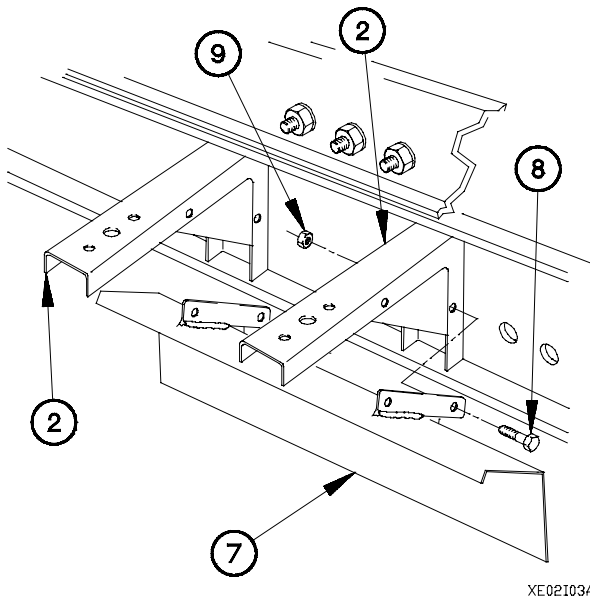

XE02103A

NOTE

Step (9) requires the aid of an assistant.

(9) Install muffler (4) on two muffler support brackets (2) with two rubber grommets (10), four rubber grommets (11), two washers (12), screws (13), washers (14), and self-locking nuts (15).

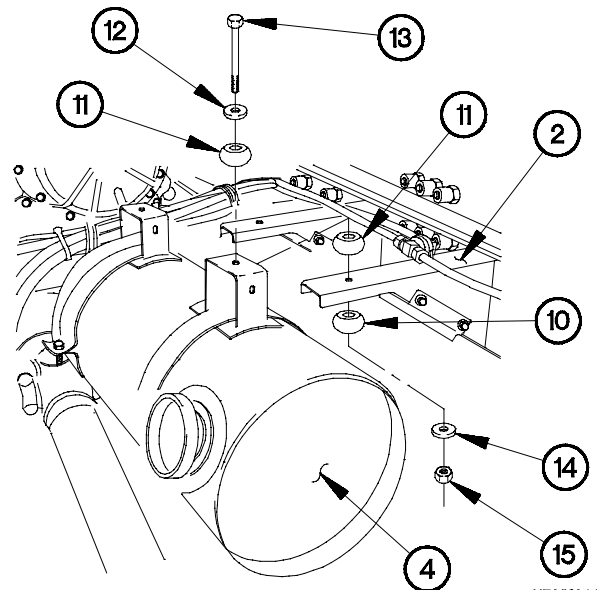

XE02104A

(10) Position tailpipe (16) on muffler (4) with clamp (17).

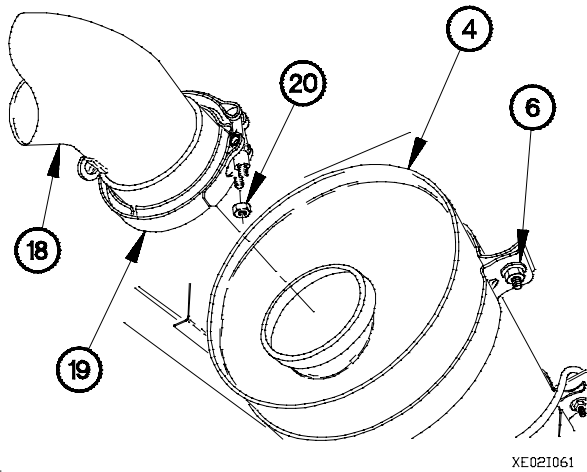
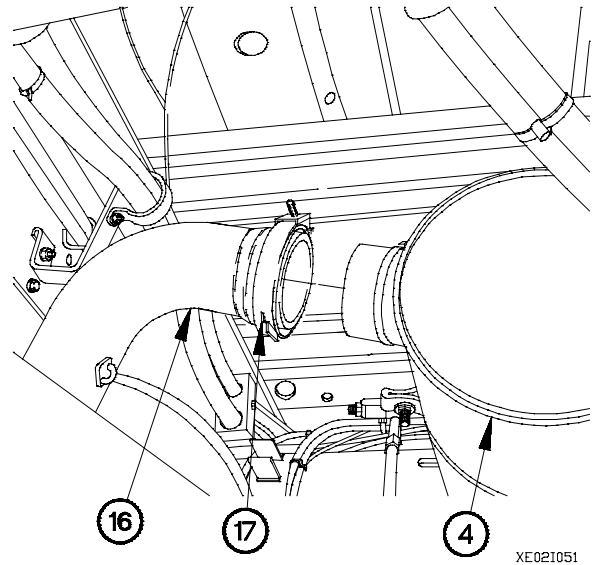

(11) Position exhaust pipe (18) on muffler (4) with clamp (19) and self-locking nut (20).

(12) Tighten self-locking nut (20) to 89-109 lb-in. (10-12 N·m).

(13) Tighten two self-locking nuts (6) to 42-52 lb-ft (51-71 N·m).

(14) Position self-locking nut (21) on clamp (17).

(15) Tighten self-locking nut (21) to 89-109 lb-in. (10-12 N·m).

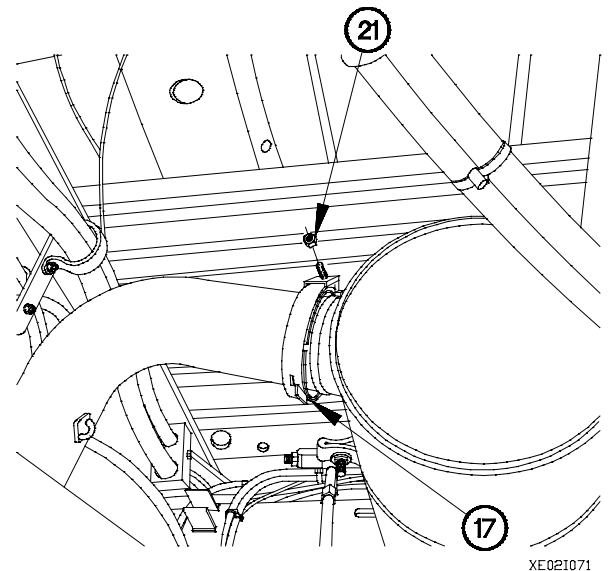

c. Follow-On Maintenance.

- (1) Start engine (TM 9-2320-366-10-1).
- (2) Check around muffler for exhaust leaks, excessive noise, and vibration.
- (3) Shut down engine (TM 9-2320-366-10-1).

End of Task.

5-3. EXHAUST PIPE REPLACEMENT

This task covers:

- a. Removal
- b. Installation
- c. Follow-On Maintenance

INITIAL SETUP

Equipment Conditions

- Engine shut down (TM 9-2320-366-10-1).
- Cab raised (TM 9-2320-366-10-1).

Materials/Parts

- Nut, Self-Locking (4) (Item 156, Appendix G)
- Nut, Self-Locking (3) (Item 129, Appendix G)

Tools and Special Tools

- Goggles, Industrial (Item 15, Appendix C)
- Tool Kit, Genl Mech (Item 46, Appendix C)
- Wrench, Torque, 0-175 lb-ft (Item 58, Appendix C)
- Wrench, Torque, 0-200 lb-in. (Item 59, Appendix C)
- Socket Set, Socket Wrench (Item 36, Appendix C)

WARNING

- Ensure exhaust system is cool before performing maintenance. Failure to comply may result in injury to personnel.
- Wear appropriate eye protection when working under vehicle due to the possibility of falling debris. Failure to comply may result in injury to personnel.
- Do not operate vehicle with exhaust pipe removed. Toxic exhaust fumes may enter cab, resulting in serious injury or death to personnel.

a. Removal.

- (1) Remove self-locking nut (1) from clamp (2). Discard self-locking nut.
- (2) Disconnect exhaust pipe (3) from muffler (4).
- (3) Remove clamp (2) from exhaust pipe (3).

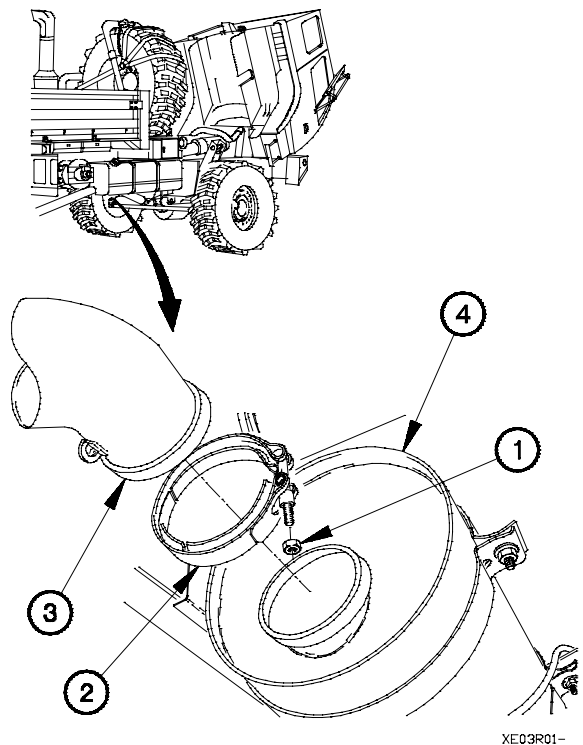

XE03R01-

- (4) Remove two self-locking nuts (5), screws (6), and loop clamp half (7) from exhaust bracket (8). Discard self-locking nut.
- (5) Remove two bolts (9) and exhaust bracket (8) from transmission (10).

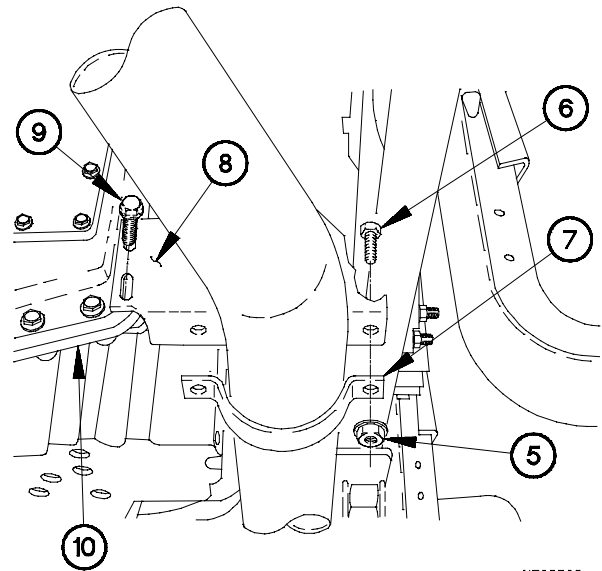

XE03R02-

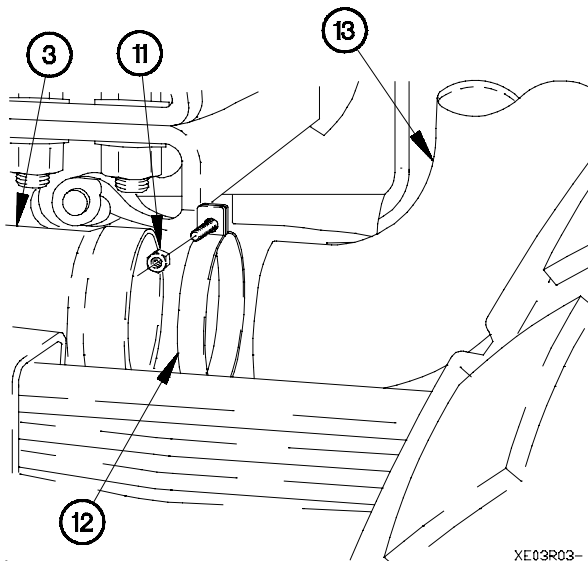

XE03R03-

- (6) Remove self-locking nut (11) from clamp (12). Discard self-locking nut.
- (7) Remove exhaust pipe (3) from exhaust pipe (13).
- (8) Remove clamp (12) from exhaust pipe (3).

- (9) Remove two self-locking nuts (14), two screws (15), and loop clamp half (16) from exhaust pipe bracket (17).

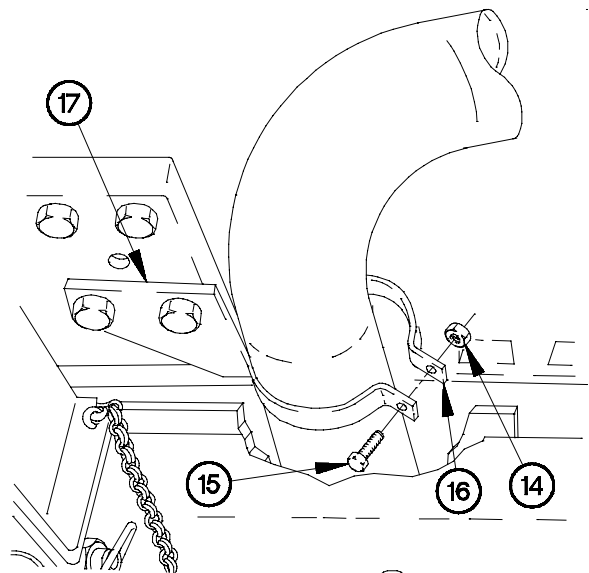

XE03R04-

5-3. EXHAUST PIPE REPLACEMENT (CONT)

- (10) Remove self-locking nut (18) from clamp (19). Discard self-locking nut.
- (11) Remove exhaust pipe (13) from rear of turbocharger (20).
- (12) Remove clamp (19) from exhaust pipe (13).

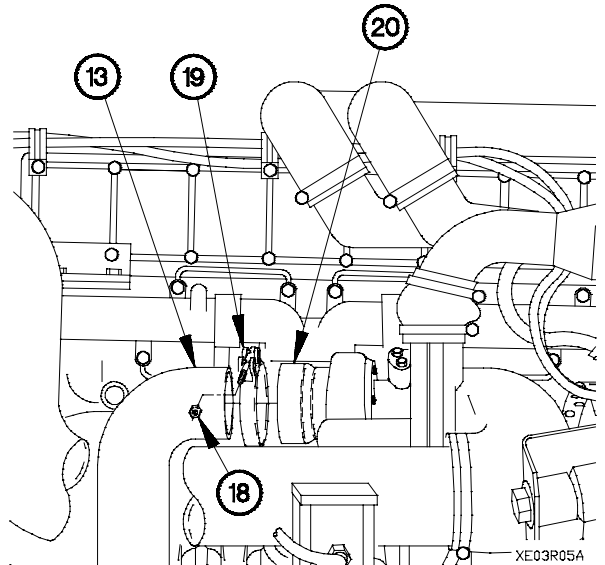

b. Installation.

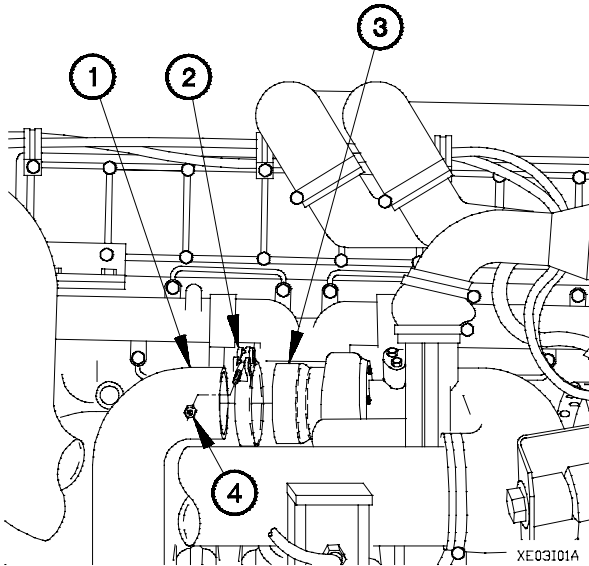

- (1) Install exhaust pipe (1) and clamp (2) to rear of turbocharger (3).
- (2) Position self-locking nut (4) on clamp (2).
- (3) Tighten self-locking nut (4) to 89-109 lb-in. (10-12 N·m).

- (4) Position loop clamp half (5) on exhaust pipe bracket (6) with two screws (7) and self-locking nuts (8).
- (5) Tighten two self-locking nuts (8) to 42-52 lb-ft (57-71 N·m).

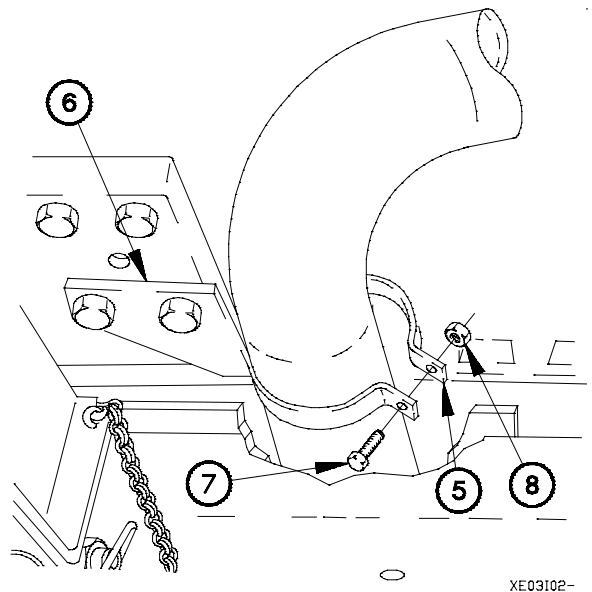

- (6) Position exhaust pipe (9) and clamp (10) on exhaust pipe (1).
- (7) Position self-locking nut (11) on clamp (10).
- (8) Tighten self-locking nut (11) to 89-109 lb-in. (10-12 N·m).

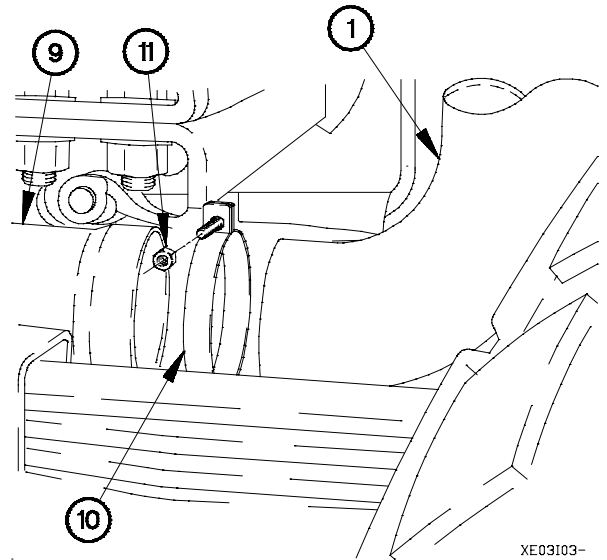

XE03103-

- (9) Position exhaust bracket (12) on transmission (13) with two bolts (14).
- (10) Tighten two bolts (14) to 44-55 lb-ft (60-75 N·m).
- (11) Position loop clamp half (15) on muffler exhaust pipe (9) with two screws (16) and self-locking nuts (17).
- (12) Tighten two self-locking nuts (17) to 42-52 lb-ft (57-71 N·m).

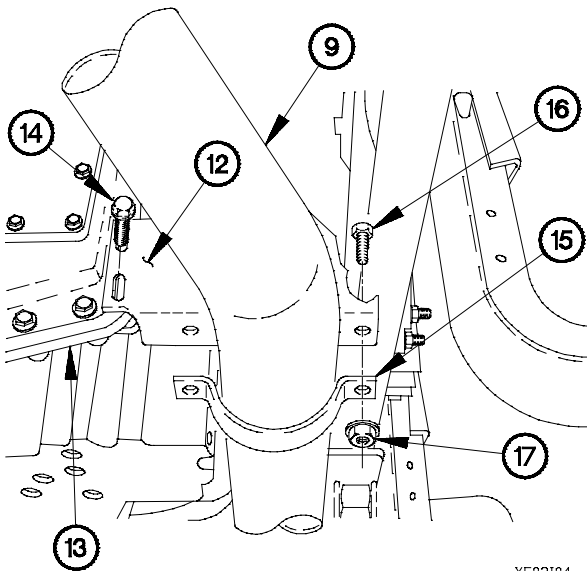

XE03104-

- (13) Position exhaust pipe (9) and clamp (18) on muffler (19).
- (14) Position self-locking nut (20) on clamp (18).
- (15) Tighten self-locking nut (20) to 89-109 lb-in. (10-12 N·m).

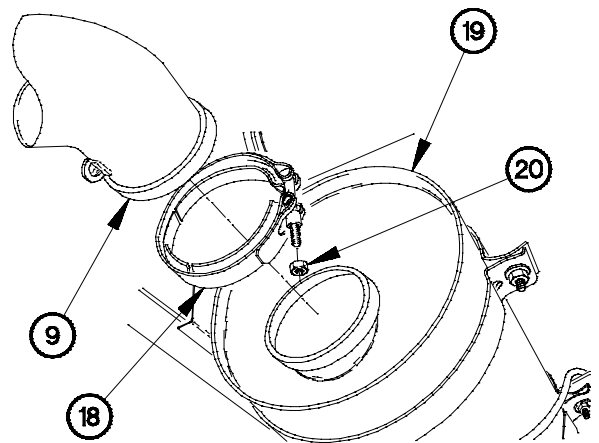

XE03105-

5-3. EXHAUST PIPE REPLACEMENT (CONT)

c. Follow-On Maintenance.

- (1) Lower cab (TM 9-2320-366-10-1).
- (2) Start engine (TM 9-2320-366-10-1).
- (3) Check for exhaust leaks, excessive noise, and vibration.
- (4) Shut down engine (TM 9-2320-366-10-1).

End of Task.

5-4. TAILPIPE REPLACEMENT

This task covers:

- a. Removal
- b. Installation
- c. Follow-On Maintenance

INITIAL SETUP

Equipment Conditions

Engine shut down (TM 9-2320-366-10-1).

Tools and Special Tools

Goggles, Industrial (Item 15, Appendix C)
 Tool Kit, Genl Mech (Item 46, Appendix C)
 Wrench, Torque, 0-175 lb-ft (Item 58, Appendix C)
 Wrench, Torque, 0-200 lb-in. (Item 59, Appendix C)
 Socket Set, Socket Wrench (Item 36, Appendix C)

Materials/Parts

Nut, Self-Locking (4) (Item 156, Appendix G)
 Nut, Self-Locking (Item 129, Appendix G)

WARNING

- Ensure exhaust system is cool before performing maintenance. Failure to comply may result in injury to personnel.
- Wear appropriate eye protection when working under vehicle due to the possibility of falling debris. Failure to comply may result in injury to personnel.

a. Removal.

- (1) Loosen hose clamp (1) on particle extraction hose (2).
- (2) Remove particle extraction hose (2) from tailpipe (3).

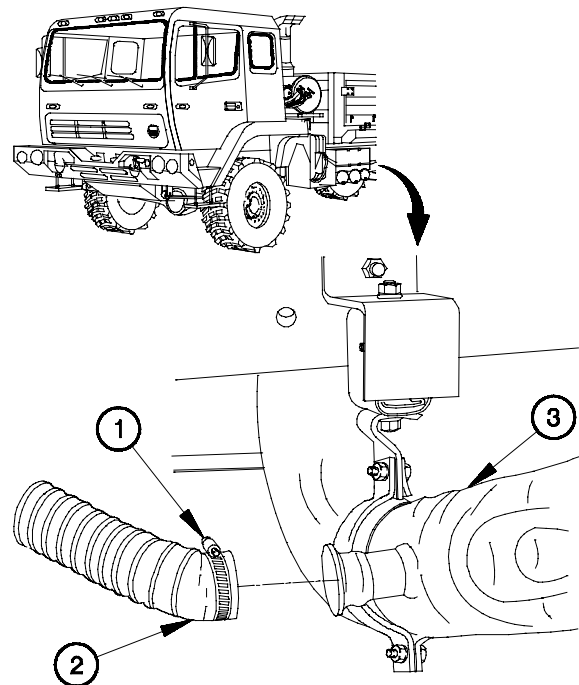

XE04R01-

5-4. TAILPIPE REPLACEMENT (CONT)

- (3) Remove self-locking nut (4) from clamp (5). Discard self-locking nut.
- (4) Disconnect tailpipe (3) from muffler (6).
- (5) Remove clamp (5) from tailpipe (3).

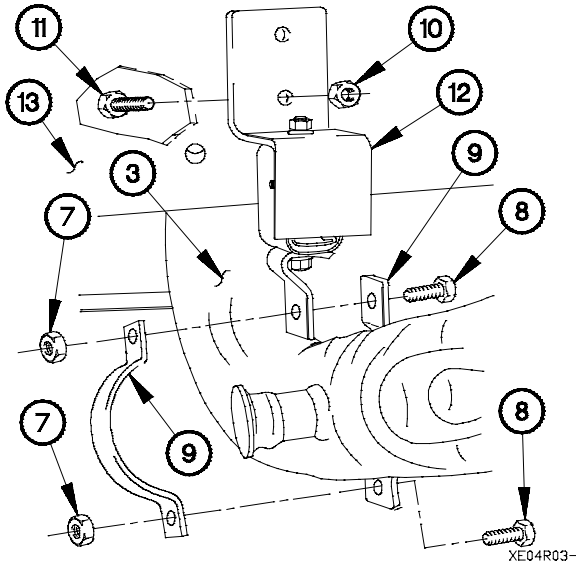
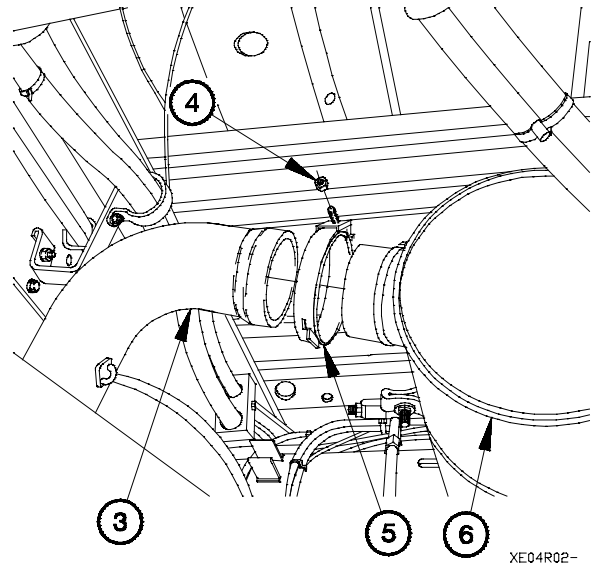

- (6) Remove two self-locking nuts (7), screws (8), and loop clamp halves (9) from tailpipe (3). Discard self-locking nuts.
- (7) Remove two self-locking nuts (10), screws (11), and tailpipe bracket (12) from frame (13). Discard self-locking nuts.

b. Installation.

- (1) Position tailpipe bracket (1) on frame (2) with two screws (3) and self-locking nuts (4).
- (2) Tighten two self-locking nuts (4) to 42-52 lb-ft (57-71 N-m).
- (3) Position two loop clamp halves (5) and tailpipe (6) on tailpipe bracket (1) with two screws (7) and self-locking nuts (8).

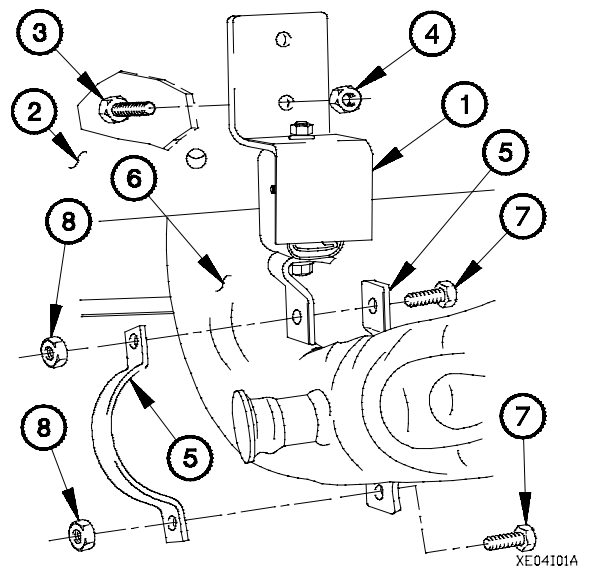

- (4) Position clamp (9) and tailpipe (6) on muffler (10).
- (5) Position self-locking nut (11) on clamp (9).
- (6) Tighten self-locking nut (11) to 89-109 lb-in. (10-12 N·m).

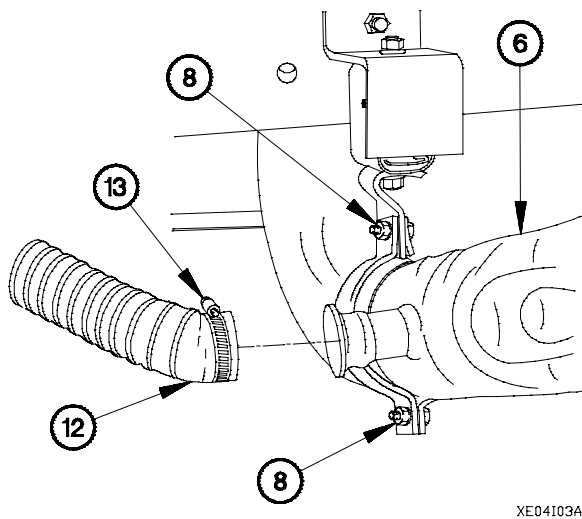
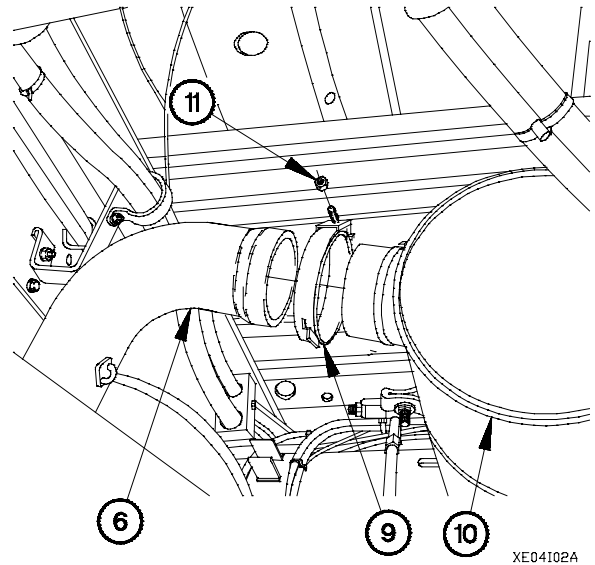

- (7) Tighten two self-locking nuts (8) to 42-52 lb-ft (57-71 N·m).
- (8) Install particle extraction hose (12) on tailpipe (6) with hose clamp (13).

c. Follow-On Maintenance.

- (1) Start engine (TM 9-2320-366-10-1).
- (2) Check around muffler and tailpipe for exhaust leaks.
- (3) Shut down engine (TM 9-2320-366-10-1).

End of Task.

CHAPTER 6 COOLING SYSTEM MAINTENANCE

RESTRICTED MAINTENANCE NOTICE

Units not authorized SC 4910-95-CL-A72 (SHOP EQUIPMENT, COMMON NO. 2) in their T.O.E. may be unable to perform some of the maintenance tasks described in this chapter. If the required tools are not authorized, the equipment must be submitted to DS Maintenance for repair.

Section I.	INTRODUCTION	6-1
6-1.	INTRODUCTION	6-1
Section II.	MAINTENANCE PROCEDURES	6-2
6-2.	RADIATOR/CHARGE AIR COOLER REPLACEMENT	6-2
6-3.	RADIATOR OVERFLOW TANK AND BRACKET REPLACEMENT/REPAIR	6-7
6-4.	RADIATOR FAN SHROUDS REPLACEMENT	6-15
6-5.	THERMOSTAT REPLACEMENT	6-25
6-6.	THERMOSTAT HOUSING REPLACEMENT	6-28
6-7.	COOLANT BYPASS TUBE REPLACEMENT	6-34
6-8.	PERSONNEL HEATER HOSES REPLACEMENT	6-42
6-9.	UPPER COOLANT TUBE AND HOSES REPLACEMENT	6-49
6-10.	LOWER COOLANT HOSE REPLACEMENT	6-55
6-11.	AIR COMPRESSOR INLET AND OUTLET COOLANT TUBES REPLACEMENT	6-59
6-12.	WATER PUMP AND FITTINGS REPLACEMENT	6-63
6-13.	DRIVE BELT AND TENSION PULLEY REPLACEMENT	6-70
6-14.	ENGINE FAN AND FAN CLUTCH ASSEMBLY REPLACEMENT	6-74

Section I. INTRODUCTION

6-1. INTRODUCTION

This chapter contains maintenance instructions for replacing and repairing cooling system components authorized by the Maintenance Allocation Chart (MAC) at the Unit Maintenance level.

Section II. MAINTENANCE PROCEDURES

6-2. RADIATOR/CHARGE AIR COOLER REPLACEMENT	
This task covers:	
<ul style="list-style-type: none"> a. Removal b. Installation 	<ul style="list-style-type: none"> c. Follow-On Maintenance
INITIAL SETUP	
<p>Equipment Conditions</p> <ul style="list-style-type: none"> ■ Radiator fan shrouds removed (para 6-4). <p>Tools and Special Tools</p> <ul style="list-style-type: none"> ■ Goggles, Industrial (Item 15, Appendix C) ■ Tool Kit, Genl Mech (Item 46, Appendix C) ■ Sling, Cargo (Item 31, Appendix C) ■ Wrench, Torque, 0-175 lb-ft (Item 58, Appendix C) ■ Adapter, Socket Wrench (Item 2, Appendix B) 	<p>Materials/Parts</p> <ul style="list-style-type: none"> Antiseize Compound (Item 58, Appendix D) Lockwasher (6) (Item 95, Appendix G) Nut, Self-Locking (4) (Item 156, Appendix G) Grommet, Nonmetallic (Item 53, Appendix G) Screw, Self-Locking (6) (Item 263, Appendix G) <p>Personnel Required</p> <ul style="list-style-type: none"> (2)

WARNING

Wear appropriate eye protection when working under vehicle due to the possibility of falling debris. Failure to comply may result in injury to personnel.

a. Removal.

- (1) Disconnect air hose (1) from fitting (2).
- (2) Remove fitting (2) from fan clutch assembly (3).

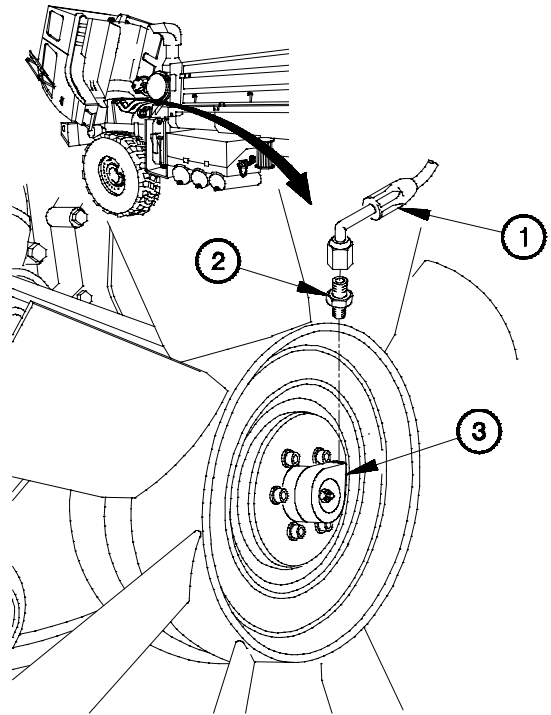

XF02R01A

NOTE

Perform steps (3) through (6) on vehicles serial number 8426 and lower that have not had the fan clutch replaced.

- (3) Remove six screws (4), lockwashers (5), and washers (6) from engine fan (7). Discard lockwashers.

CAUTION

Mark front of engine fan before removing. Failure to comply may result in damage to equipment.

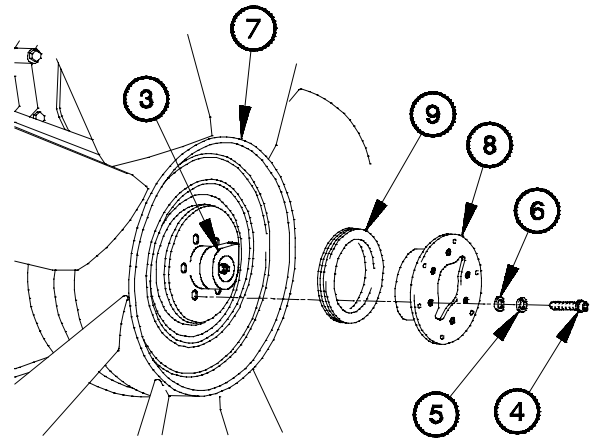

XF02R021

- (4) Remove engine fan (7) from fan clutch assembly (3).
- (5) Remove fan support plate (8) from engine fan (7).
- (6) Remove grommet (9) from engine fan (7). Discard grommet.

NOTE

Perform steps (6.1) and (6.2) on vehicles serial number 8427 and higher and on vehicles that have had the fan, clutch replaced.

- (6.1) Remove six nuts (9.1), lockwashers (9.2), and washers (9.3) from engine fan (9.4). Discard lockwashers.

CAUTION

Mark front of engine fan before removal. Failure to comply may result in damage to equipment.

- (6.2) Remove engine from (9.4) from fan clutch assembly (9.5).

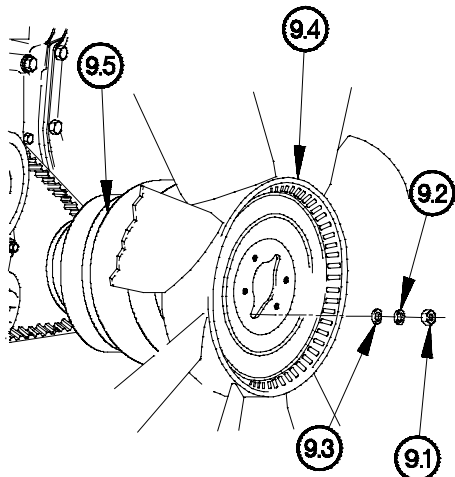

XF02R03B

6-2. RADIATOR/CHARGE AIR COOLER REPLACEMENT (CONT)

(7) Remove four self-locking nuts (10) and screws (11) from radiator mounting brackets (12). Discard self-locking nuts.

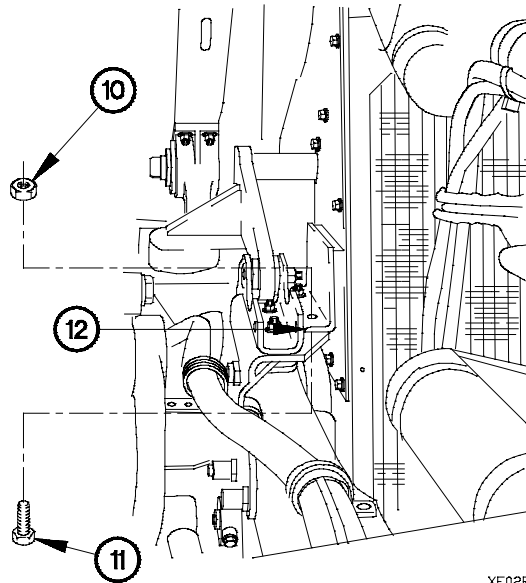

XF02R04B

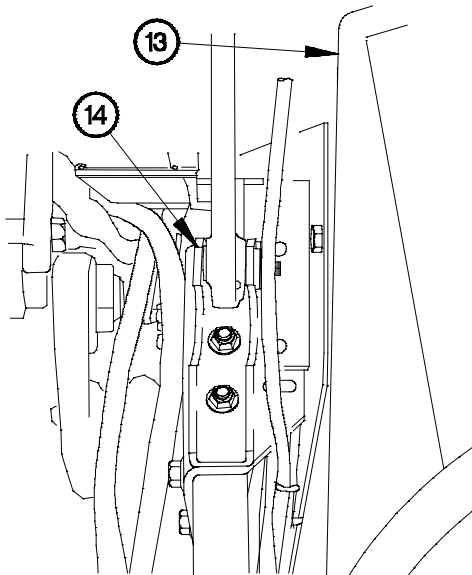

XF02R051

NOTE

- Additional coolant may drain out of radiator during removal.
 - Steps (8) and (9) require the aid of an assistant.
- (8) Slide radiator (13) to the rear approximately four inches, enough to clear left and right cab hinge pins (14).

WARNING

- Radiator and charge air cooler assembly weigh approximately 160 lbs (73 Kgs). Attach a suitable lifting device prior to removal. Failure to comply may result in injury to personnel or damage to equipment.
- Cargo sling must be placed under charge air cooler inlet and outlet ports. Failure to comply may result in injury to personnel or damage to equipment.

- (9) Remove radiator (13) and charge air cooler (15) from vehicle.
- (10) Remove six screws (16) and charge air cooler (15) from two radiator mounting brackets (12).
- (11) Remove ten screws (17) and two radiator mounting brackets (12) from radiator (13).

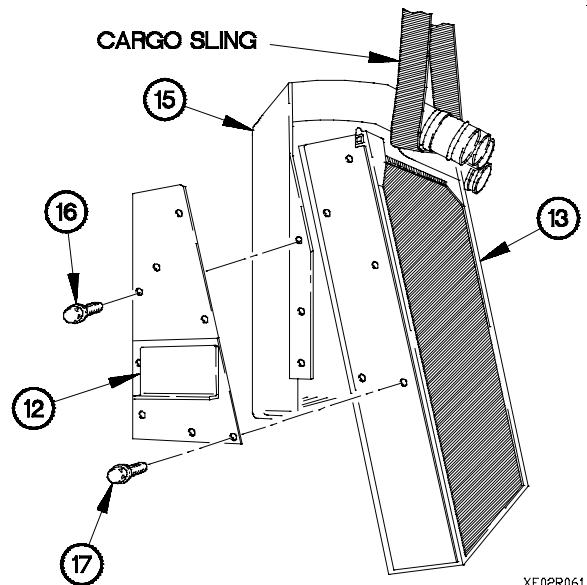

XF02R061

b. Installation.

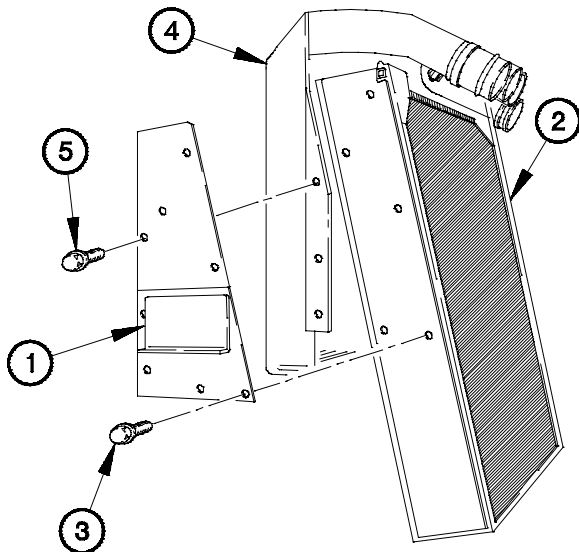

XF02I01-

- (1) Position two radiator mounting brackets (1) on radiator (2) with ten screws (3).
- (2) Tighten ten screws (3) to 20-26 lb-ft (27-35 N·m).
- (3) Position charge air cooler (4) between two radiator mounting brackets (1) with six screws (5).
- (4) Tighten six screws (5) to 20-26 lb-ft (27-35 N·m).

6-2. RADIATOR/CHARGE AIR COOLER REPLACEMENT (CONT)

WARNING

- Radiator and charge air cooler assembly weigh approximately 160 lbs (73 Kgs). Attach a suitable lifting device prior to installation. Failure to comply may result in injury to personnel or damage to equipment.
- Cargo sling must be placed under charge air cooler inlet port and outlet port. Failure to comply may result in injury to personnel or damage to equipment.

CAUTION

Use caution when lowering radiator and charge air cooler into vehicle. Failure to comply may result in damage to equipment.

NOTE

Step (5) requires the aid of an assistant.

- (5) Position radiator (2) and charge air cooler (4) in vehicle.

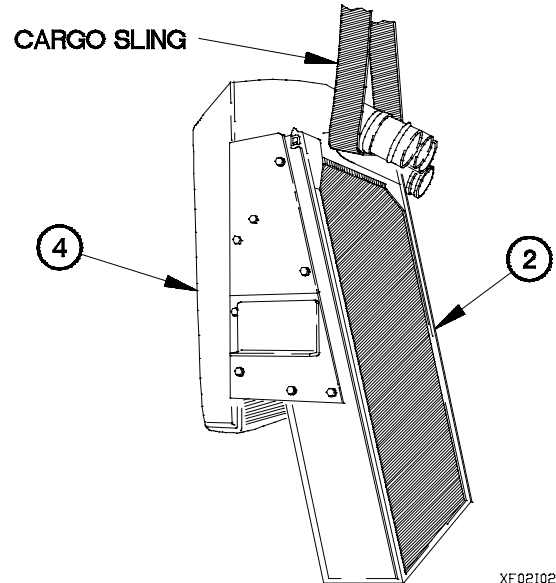

XF02102-

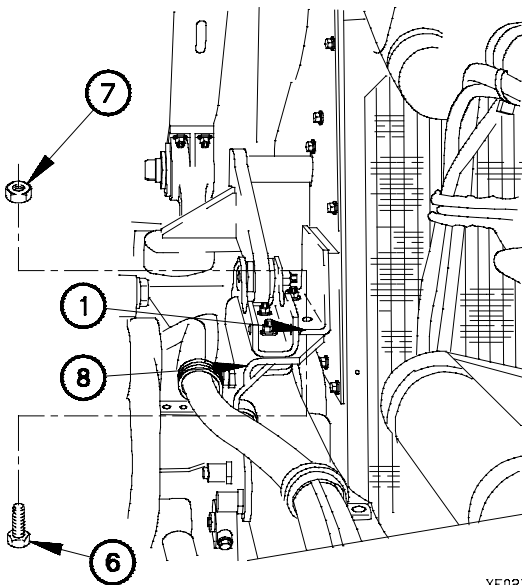

XF02103-

- (6) Position four screws (6) and self-locking nuts (7) through frame rails (8) and two radiator mounting brackets (1).
- (7) Tighten four self-locking nuts (7) to 42-52 lb-ft (57-71 N·m).

CAUTION

Ensure engine fan is positioned with mark facing forward. Failure to comply may result in damage to equipment.

NOTE

Perform steps (7.1) through (7.3) on vehicles serial number 8427 and higher and on vehicles that have had the fan clutch replaced.

- (7.1) Position engine fan (8.1) on fan clutch assembly (8.2) with six washers (8.3), lockwashers (8.4) and nuts (8.5).
- (7.2) Tighten six nuts (8.5) to 15 lb-ft (20 N·m) in sequence shown.
- (7.3) Re-tighten six nuts (8.5) to 23-29 lb-ft (31-39 N·m) in sequence shown.

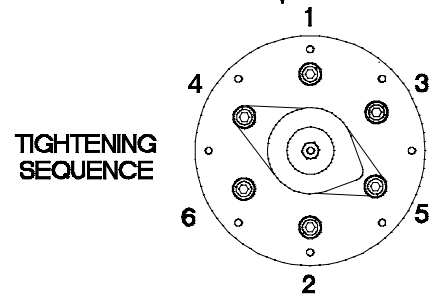
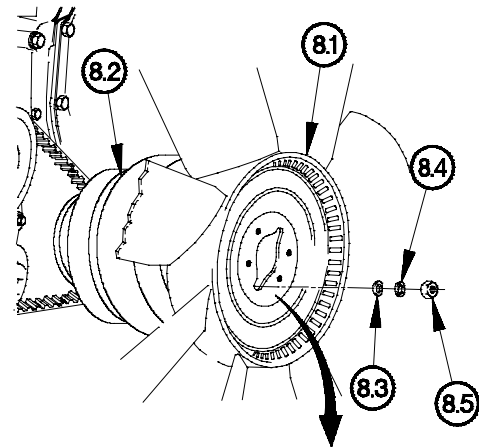

XF02104B

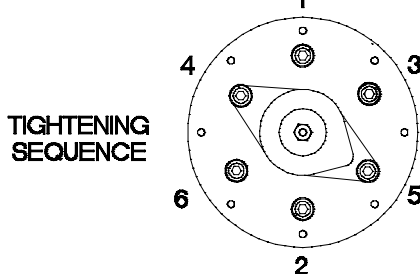
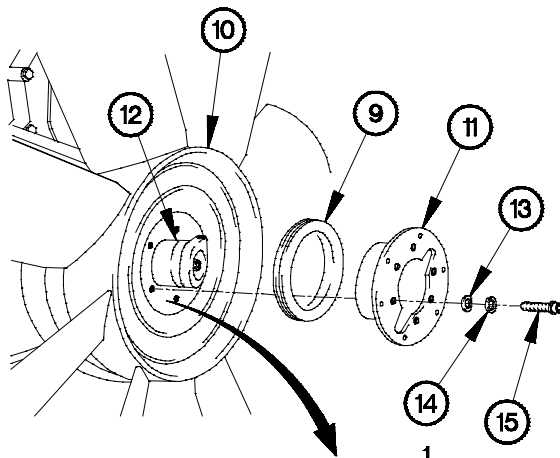

XF02105B

NOTE

Perform steps (8) through (12) on vehicles serial number 8426 and lower that have not had fan clutch replaced.

- (8) Install grommet (9) on engine fan (10).
- (9) Install fan support plate (11) on engine fan (10).
- (10) Position engine fan (10) and fan support plate (11) on fan clutch assembly (12) with six washers (13), lockwashers (14), and screws (15).
- (11) Tighten six screws (15) to 15 lb-ft (20 N·m) in sequence shown.
- (12) Re-tighten six screws (15) to 22-32 lb-ft (30-44 N·m) in sequence shown.

6-2. RADIATOR/CHARGE AIR COOLER REPLACEMENT (CONT)

WARNING

Adhesives, solvents, and sealing compounds can burn easily, can give off harmful vapors, and are harmful to skin and clothing. Keep away from open fire and use in a well-ventilated area. If adhesive, solvent, or sealing compound gets on skin or clothing, wash immediately with soap and water. Failure to comply may result in injury to personnel.

- (13) Apply antiseize compound to threads of fitting (16).
- (14) Install fitting (16) in fan clutch assembly (12).
- (15) Connect air hose (17) to fitting (16).

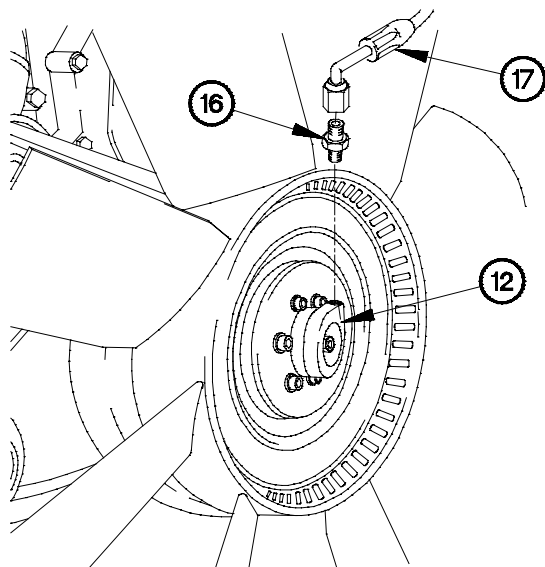

XF02106B

c. Follow-On Maintenance.

Install radiator fan shrouds (para 6-4).

End of Task.

6-3. RADIATOR OVERFLOW TANK AND BRACKET REPLACEMENT/REPAIR

This task covers:

- a. Radiator Overflow Tank Removal
- b. Radiator Overflow Tank Disassembly
- c. Radiator Overflow Tank Assembly
- d. Radiator Overflow Tank Installation
- e. Radiator Overflow Tank Bracket Removal
- f. Radiator Overflow Tank Bracket Installation
- g. Follow-On Maintenance

INITIAL SETUP

Equipment Conditions

Engine shut down (TM 9-2320-366-10-1).
Cab raised (TM 9-2320-366-10-1).

Tools and Special Tools (Cont)

Wrench, Torque, 0-200 lb-in. (Item 59, Appendix C)

Tools and Special Tools

Pan, Drain (Item 24, Appendix C)
Goggles, Industrial (Item 15, Appendix C)
Tool Kit, Genl Mech (Item 46, Appendix C)
Screwdriver Attachment, Socket Wrench (Item 48, Appendix B)
Socket Set, Socket Wrench (Item 36, Appendix C)
Wrench, Torque, 0-175 lb-ft (Item 58, Appendix C)

Materials/Parts

Antiseize Compound (Item 58, Appendix D)
Antifreeze, Ethylene Glycol, Permanent (Item 12, Appendix D)
Nut, Self-Locking (2) (Item 167, Appendix G)
Nut, Self-Locking (3) (Item 156, Appendix G)
Nut, Self-Locking (Item 152, Appendix G)



Coolant may be very hot and under pressure from engine operation. Ensure engine is cool before performing maintenance. Failure to comply may result in injury to personnel.

a. Radiator Overflow Tank Removal.

- (1) Remove radiator cap (1) from radiator overflow tank (2).
- (2) Position drain pan under radiator draincock (3).



Wear appropriate eye protection when working under vehicle due to the possibility of falling debris. Failure to comply may result in injury to personnel.

- (3) Open radiator draincock (3) and drain approximately three gallons (11 L) of coolant.
- (4) Close radiator draincock (3).
- (5) Loosen hose clamp (4) on lower coolant hose (5).
- (6) Remove lower coolant hose (5) from radiator overflow tank (2).

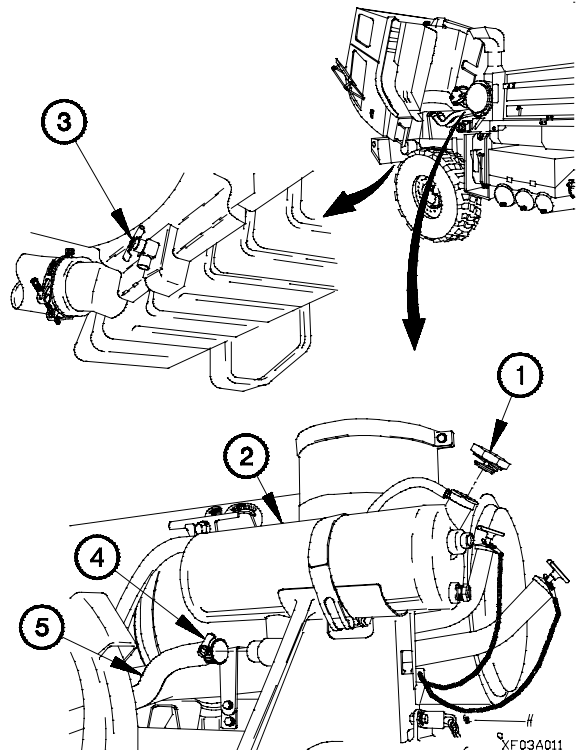

6-3. RADIATOR OVERFLOW TANK AND BRACKET REPLACEMENT/REPAIR (CONT)

- (7) Loosen two hose clamps (6) on upper coolant hoses (7 and 8).
- (8) Remove upper coolant hoses (7 and 8) from radiator overflow tank (2).

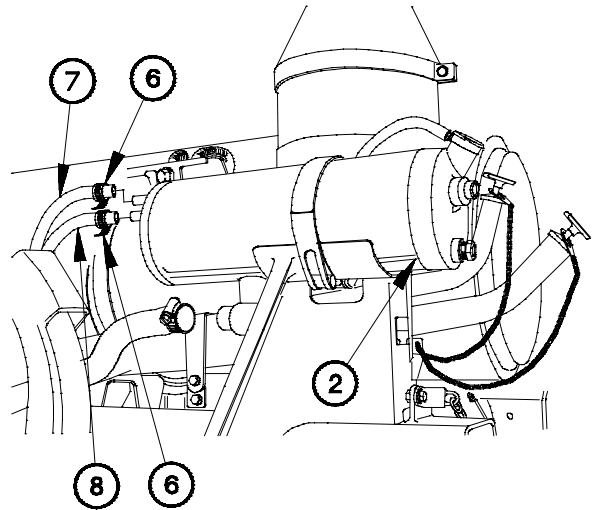

XF03A021

- (9) Loosen screw (9) and remove clamp (10) from bracket (11).
- (10) Remove radiator overflow tank (2) from bracket (11).

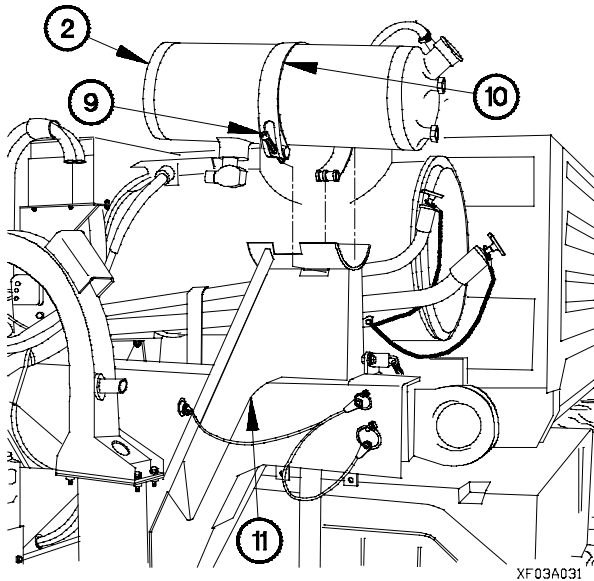

XF03A031

b. Radiator Overflow Tank Disassembly.

NOTE

Perform step (1) on all models except M1093/M1094.

- (1) Remove 90-degree fitting (1) from radiator overflow tank (2).

NOTE

Perform step (2) on M1093/M1094.

- (2) Remove 45-degree fitting (3) from radiator overflow tank (2).

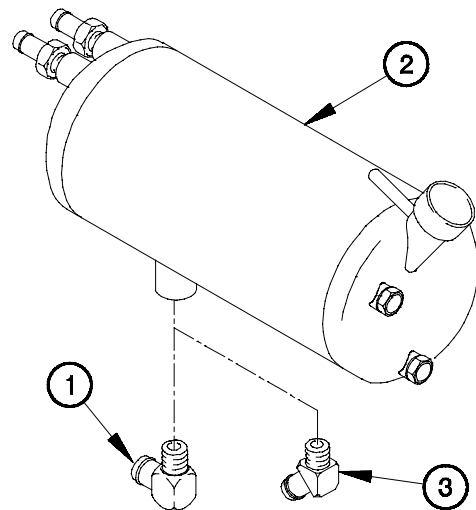

XF03B01A

- (3) Remove two adapters (4) from radiator overflow tank (2).
- (4) Remove two sightglasses (5) from radiator overflow tank (2).

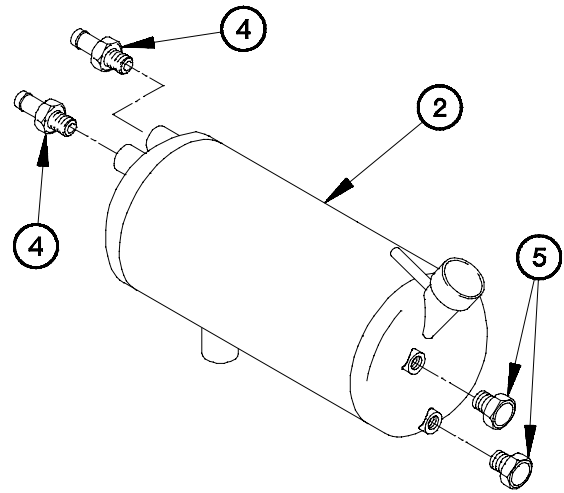

XF03B02A

c. Radiator Overflow Tank Assembly.

WARNING

Adhesives, solvents, and sealing compounds can burn easily, can give off harmful vapors, and are harmful to skin and clothing. Keep away from open fire and use in a well-ventilated area. If adhesive, solvent, or sealing compound gets on skin or clothing, wash immediately with soap and water. Failure to comply may result in injury to personnel.

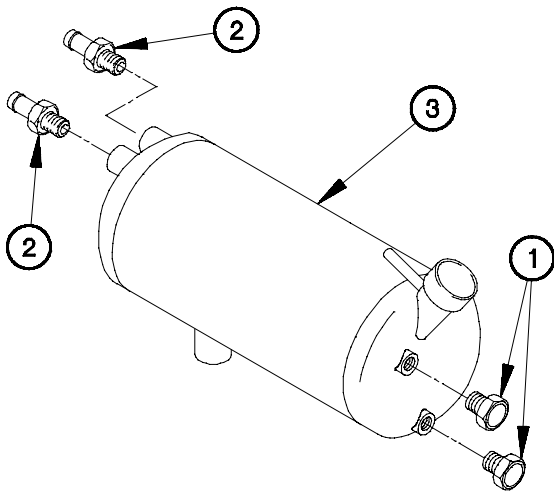

XF03C01A

- (1) Apply antiseize compound to threads of two sightglasses (1) and adapters (2).
- (2) Install two sightglasses (1) in radiator overflow tank (3).
- (3) Install two adapters (2) in radiator overflow tank (3).

6-3. RADIATOR OVERFLOW TANK AND BRACKET REPLACEMENT/REPAIR (CONT)

WARNING

Adhesives, solvents, and sealing compounds can burn easily, can give off harmful vapors, and are harmful to skin and clothing. Keep away from open fire and use in a well-ventilated area. If adhesive, solvent, or sealing compound gets on skin or clothing, wash immediately with soap and water. Failure to comply may result in injury to personnel.

NOTE

Perform step (4) on M1093/M1094.

- (4) Install 45-degree fitting (4) in radiator overflow tank (3).

NOTE

Perform step (5) on all models except M1093/M1094.

- (5) Install 90-degree fitting (5) in radiator overflow tank (3).

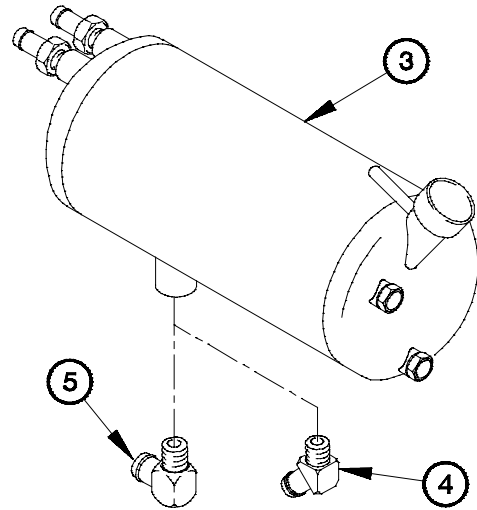

XF03C02A

d. Radiator Overflow Tank Installation.

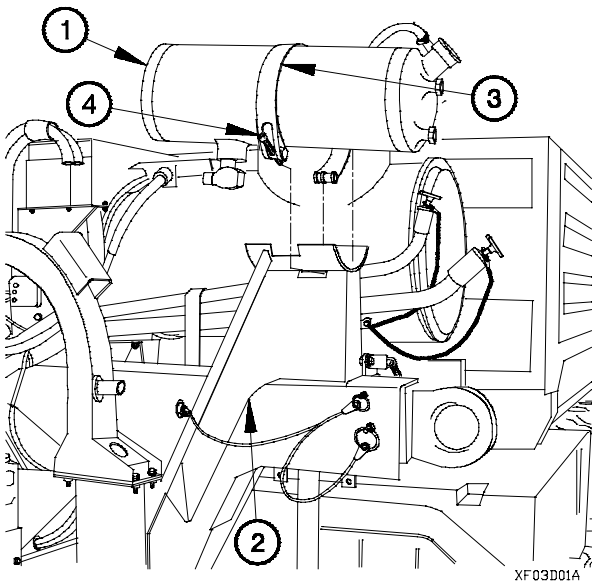

XF03D01A

NOTE

If replacing radiator overflow tank 12421810 with radiator overflow tanks 12421810-001 or 12421810-002, replace clamp 12421379-004 with clamp 12421379-006.

- (1) Position radiator overflow tank (1) on bracket (2) with clamp (3) and screw (4).
- (2) Tighten screw (4) to 108-132 lb-in. (12-15 N-m).

- (3) Position two hose clamps (5) and upper coolant hoses (6 and 7) on radiator overflow tank (1).
- (4) Position hose clamp (8) and lower coolant hose (9) on radiator overflow tank (1).
- (5) Tighten two hose clamps (5) and hose clamp (8) to 36-44 lb-in. (4-5 N-m).

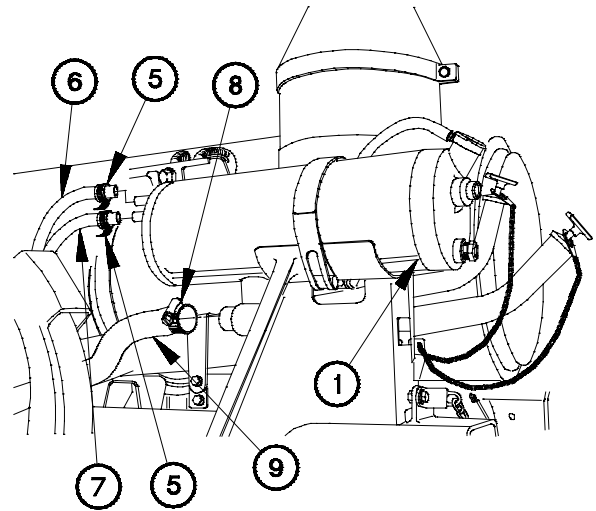

e. Radiator Overflow Tank Bracket Removal.

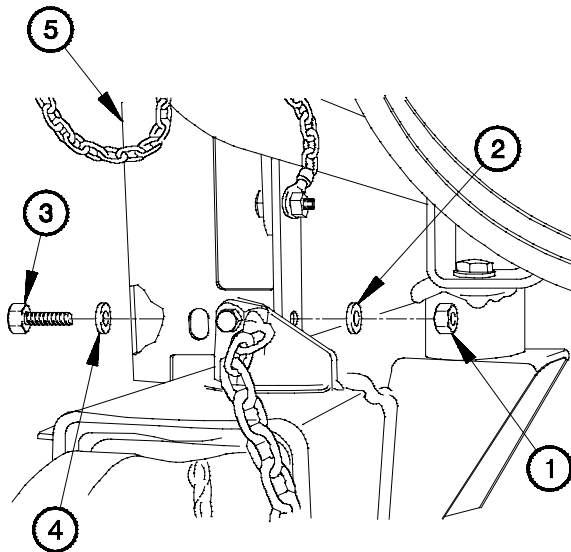

XF03D02A

NOTE

Perform step (1) on all models except M1093/M1094.

- (1) Remove self-locking nut (1), washer (2), screw (3), and washer (4) from radiator overflow tank bracket (5). Discard self-locking nut.

NOTE

Perform step (2) on M1093/M1094.

- (2) Remove self-locking nut (6), washer (7), screw (8), washer (9), and spacer (10) from radiator overflow tank bracket (5). Discard self-locking nut.

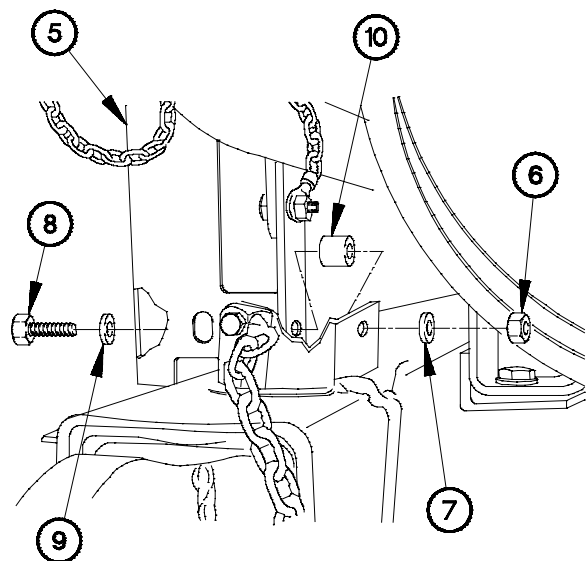

XF03E02A

6-3. RADIATOR OVERFLOW TANK AND BRACKET REPLACEMENT/REPAIR (CONT)

- (3) Remove self-locking nut (11), screw (12), and chain (13), from radiator overflow tank bracket (5). Discard self-locking nut.

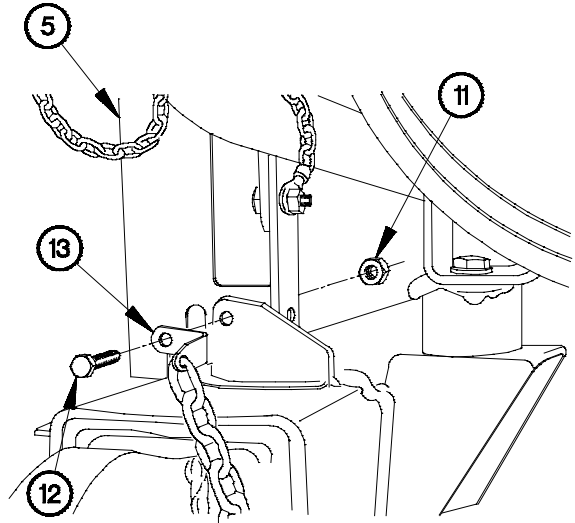

XF03E03B

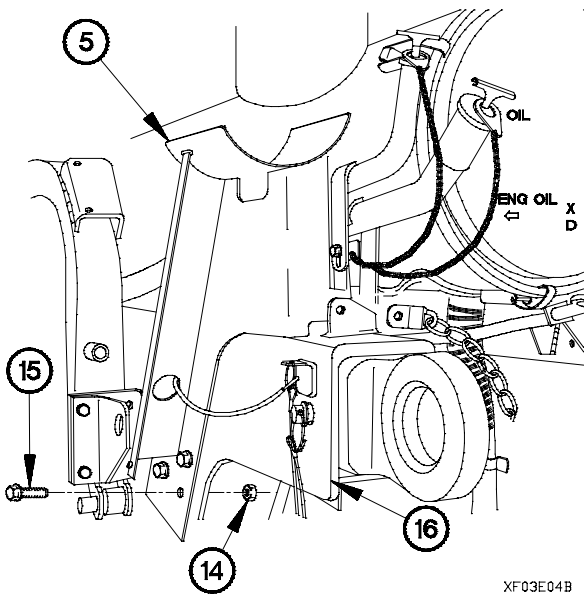

XF03E04B

- (4) Remove three self-locking nuts (14), bolts (15), and radiator overflow tank bracket (5) from front lifting bracket (16). Discard self-locking nuts.

f. Radiator Overflow Tank Bracket Installation.

- (1) Position radiator overflow tank bracket (1) on front lifting bracket (2) with three bolts (3) and self-locking nuts (4).
- (2) Tighten three bolts (3) to 44-56 lb-ft (60-76 N-m).

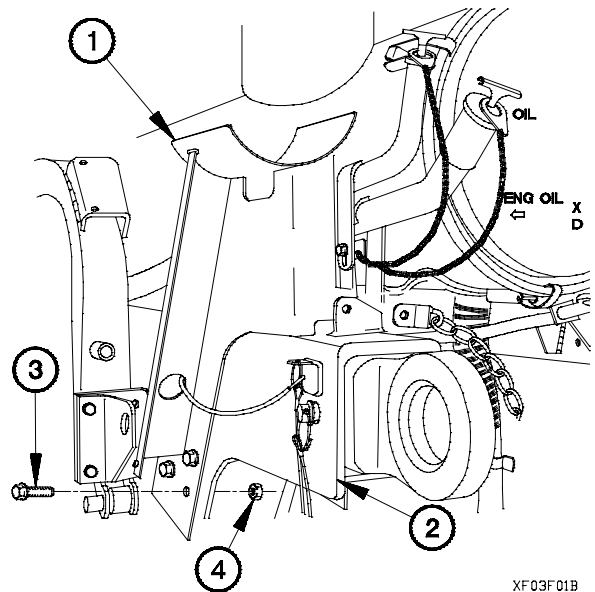

XF03F01B

- (3) Position chain (5), screw (6) and self-locking nut (7) in radiator overflow tank bracket (1).
- (4) Tighten screw (6) to 22-26 lb-ft (30-35 N·m).

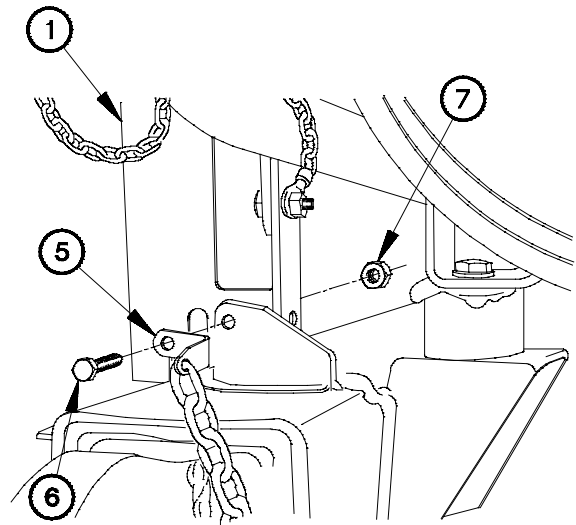

XF03F02B

NOTE

Perform steps (5) and (6) on M1093/ M1094.

- (5) Position washer (8), screw (9), spacer (10), washer (11), and self-locking nut (12) in radiator overflow tank bracket (1).
- (6) Tighten self-locking nut (12) to 22-26 lb-ft (30-35 N·m).

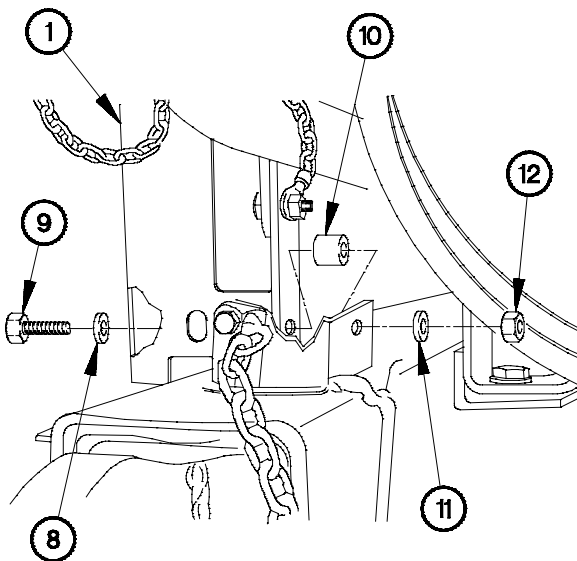

XF03F03A

NOTE

Perform steps (7) and (8) on all models except M1093/M1094.

- (7) Position washer (13), screw (14), washer (15), and self-locking nut (16) in radiator overflow tank bracket (1).
- (8) Tighten self-locking nut (16) to 22-26 lb-ft (30-35 N·m).

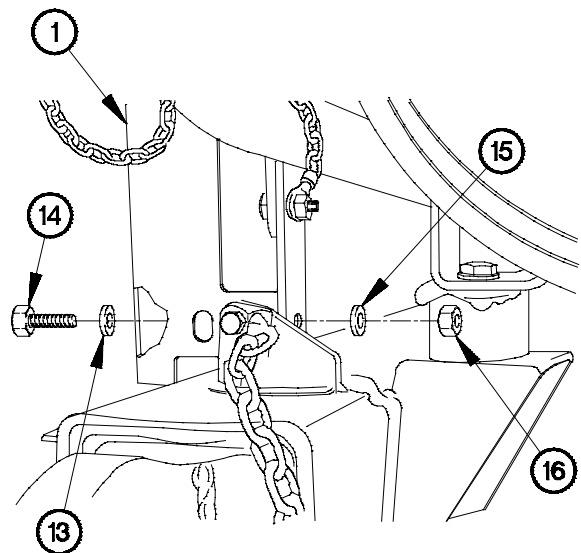

XF03F04A

6-3. RADIATOR OVERFLOW TANK AND BRACKET REPLACEMENT/REPAIR (CONT)

g. Follow-On Maintenance.

- (1) Add coolant to radiator overflow tank (TM 9-2320-366-10-2).
- (2) Lower cab (TM 9-2320-366-10-1).
- (3) Start engine (TM 9-2320-366-10-1).
- (4) Check for coolant leaks under vehicle.
- (5) Check coolant level after normal operating temperature is reached. Add coolant as needed (TM 9-2320-366-10-2).
- (6) Raise cab (TM 9-2320-366-10-1).
- (7) Check for coolant leaks around radiator overflow tank.
- (8) Lower cab (TM 9-2320-366-10-1).
- (9) Shut down engine (TM 9-2320-366-10-1).

End of Task.

6-4. RADIATOR FAN SHROUDS REPLACEMENT

This task covers:

- a. Top Radiator Fan Shroud Removal
- b. Top Radiator Fan Shroud Installation
- c. Bottom Radiator Fan Shroud Removal
- d. Bottom Radiator Fan Shroud Installation
- e. Follow-On Maintenance

INITIAL SETUP

Equipment Conditions

Turbocharger to charge air cooler tube/hoses removed (para 4-4).
 Charge air cooler to air inlet elbow tubes/hoses removed (para 4-5).
 Upper coolant tube and hoses removed (para 6-9).

Tools and Special Tools

Goggles, Industrial (Item 15, Appendix C)
 Container (52 qt (50 L) capacity)
 Socket Set, Socket Wrench (Item 35, Appendix C)

Tools and Special Tools (Cont)

Tool Kit, Genl Mech (Item 44, Appendix C)
 Wrench, Torque, 0-175 lb-ft (Item 57, Appendix C)
 Wrench, Torque, 0-200 lb-in. (Item 58, Appendix C)
 Wrench, Torque, 0-75 lb-in. (Item 86, Appendix B)

Materials/Parts

Nut, Self-Locking (6) (Item 116, Appendix G)
 Antifreeze, Ethylene Glycol, Permanent (Item 13, Appendix D)
 Sealing Compound (Item 58, Appendix D)

WARNING

Wear appropriate eye protection when working under vehicle due to the possibility of falling debris. Failure to comply may result in injury to personnel.

a. Top Radiator Fan Shroud Removal.

- (1) Loosen hose clamp (1) on radiator vent hose (2).
- (2) Disconnect radiator vent hose (2) from radiator (3).
- (3) Disconnect fan clutch hoses (4 and 5) from 90-degree fitting (6).

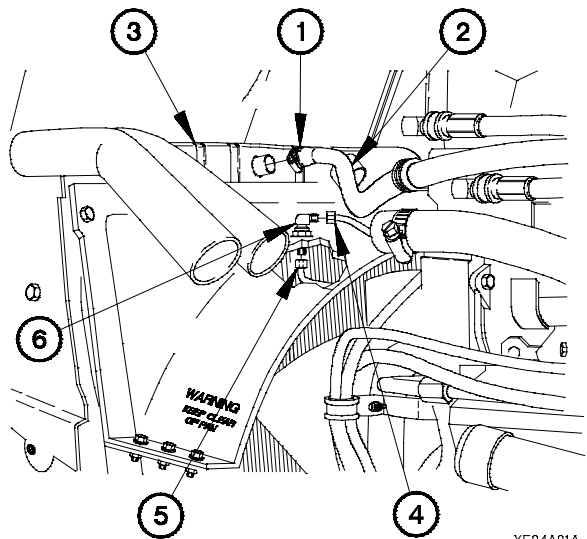

6-4. RADIATOR FAN SHROUDS REPLACEMENT (CONT)

- (4) Remove three self-locking nuts (7), six washers (8), and three screws (9) from left side of top radiator fan shroud (10). Discard self-locking nuts.
- (5) Remove screw (11) and washer (12) from left side of top radiator fan shroud (10).

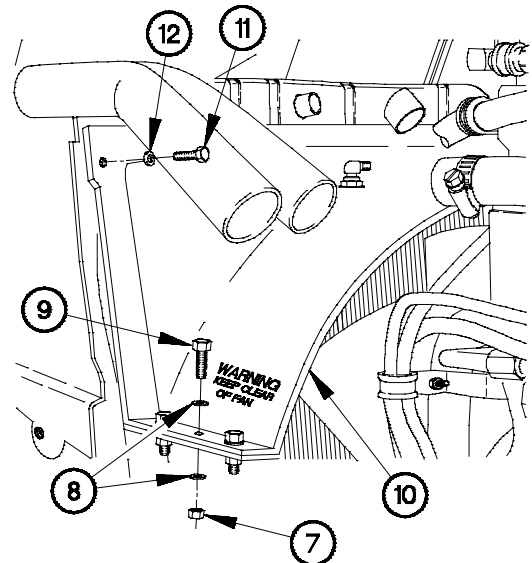

XF04A02A

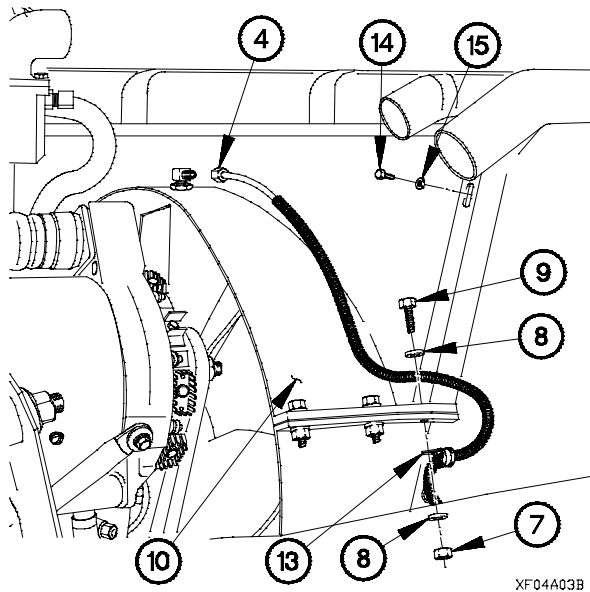

XF04A03B

- (6) Remove three self-locking nuts (7), six washers (8), three screws (9), clamp (13), and fan clutch hose (4) from right side of top radiator fan shroud (10). Discard self-locking nuts.
- (7) Remove screw (14) and washer (15) from right side of top radiator fan shroud (10).
- (8) Remove top radiator fan shroud (10) from vehicle.

- (9) Remove 90-degree fitting (6) from pipe coupling (11).
- (10) Remove fitting (12) from pipe coupling (11).
- (11) Remove nut (13), washer (14), and pipe coupling (11) from top radiator fan shroud (10).

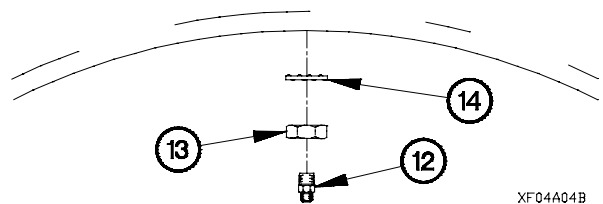
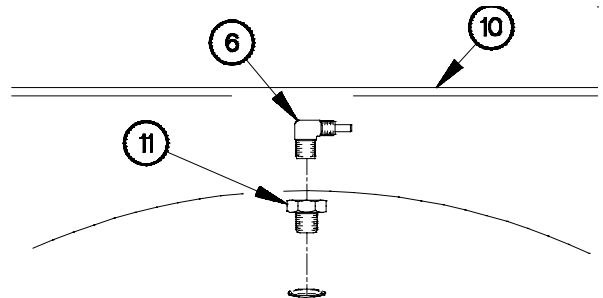

XF04A04B

b. Top Radiator Fan Shroud Installation.

- (1) Install coupling (1) in top radiator fan shroud (2) with washer (3) and nut (4).

WARNING

Adhesives, solvents, and sealing compounds can burn easily, can give off harmful vapors, and are harmful to skin and clothing. To avoid injury or death, keep away from open fire and use in a well-ventilated area. If adhesive, solvent, or sealing compound gets on skin or clothing, wash immediately with soap and water. Failure to comply may result in injury to personnel.

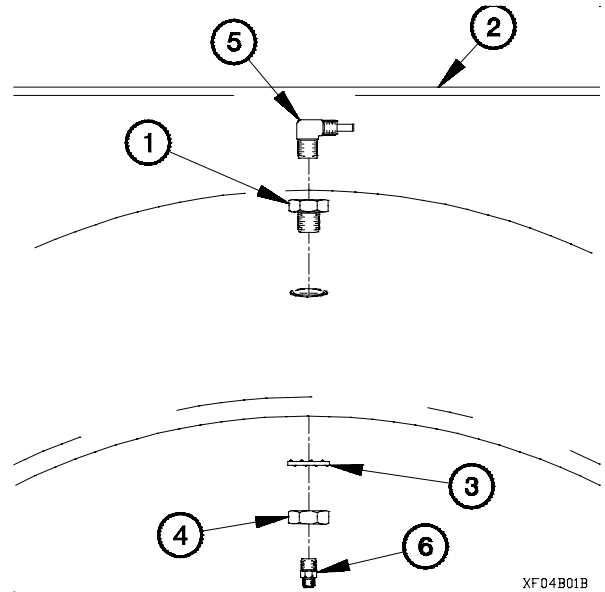

- (2) Apply sealing compound to threads of 90-degree fitting (5) and fitting (6).
- (3) Install fitting (6) in pipe coupling (1).
- (4) Install 90-degree fitting (5) in pipe coupling (1).

- (5) Position top radiator fan shroud (2) on vehicle.

WARNING

Adhesive sealant MIL-S-46163 can damage your eyes. Wear safety goggles/glasses when using; avoid contact with eyes. If sealant contacts eyes, flush eyes with water and get immediate medical attention. Failure to comply may result in injury to personnel.

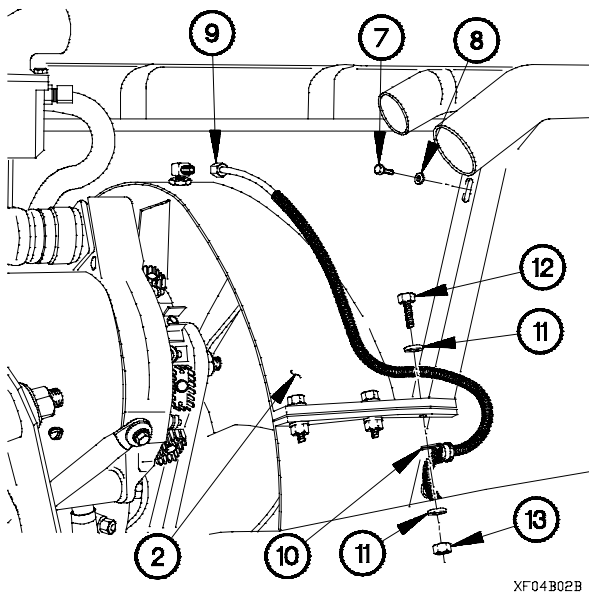

- (6) Apply sealing compound to threads of screw (7).
- (7) Position washer (8) and screw (7) on right side of radiator fan shroud (2).
- (8) Tighten screw (7) to 84-108 lb-in. (10-12 N·m).
- (9) Position fan clutch hose (9), clamp (10), six washers (11), three screws (12) and self-locking nuts (13) on right side of top radiator fan shroud (2).
- (10) Tighten three self-locking nuts (13) to 84-108 lb-in. (10-12 N·m).

6-4. RADIATOR FAN SHROUDS REPLACEMENT (CONT)

- (11) Apply sealing compound to threads of screw (14).
- (12) Install washer (15) and screw (14) on left side of top radiator fan shroud (2).
- (13) Tighten screw (14) to 84-108 lb-in. (10-12 N-m).
- (14) Position six washers (11), three screws (12), and self-locking nuts (13) on left side of top radiator fan shroud (2).
- (15) Tighten three self-locking nuts (13) to 84-108 lb-in. (10-12 N-m).

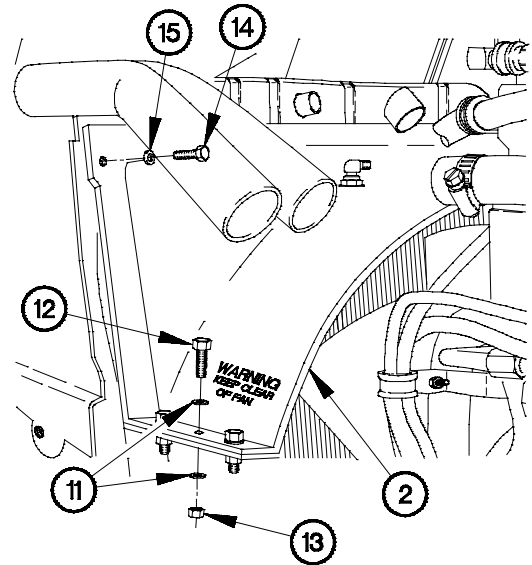

XF04B03B

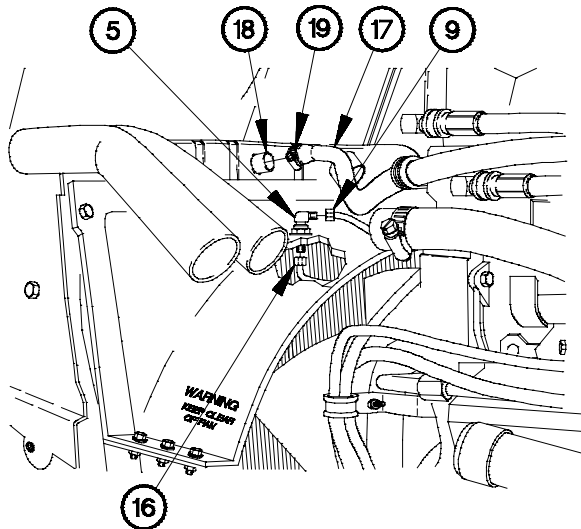

XF04B04B

- (16) Connect fan clutch hoses (9 and 16) to 90-degree fitting (5).
- (17) Install radiator vent hose (17) on radiator (18) with hose clamp (19).

c. Bottom Radiator Fan Shroud Removal.

- (1) Position container under radiator (1).
- (2) Remove radiator cap (2) from radiator overflow tank (3).
- (3) Open radiator draincock (4) and drain coolant from radiator (1).
- (4) Close radiator draincock (4).

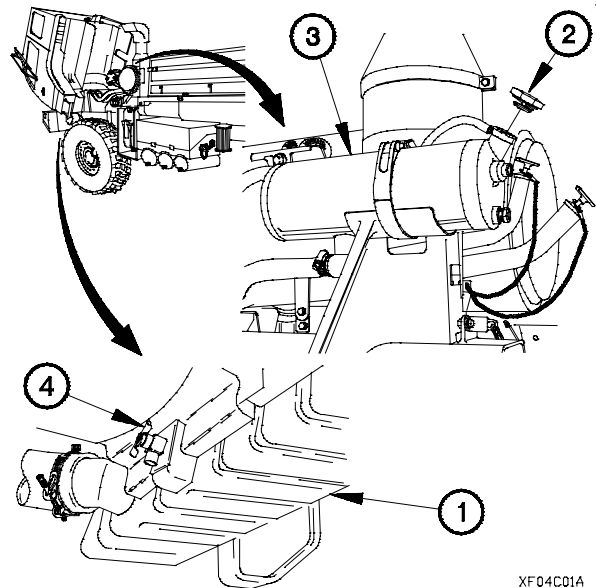

XF04C01A

- (5) Loosen clamps (5 and 6) on lower coolant hose (7).
- (6) Remove lower coolant hose (7) from radiator (1) and transmission oil cooler (8).

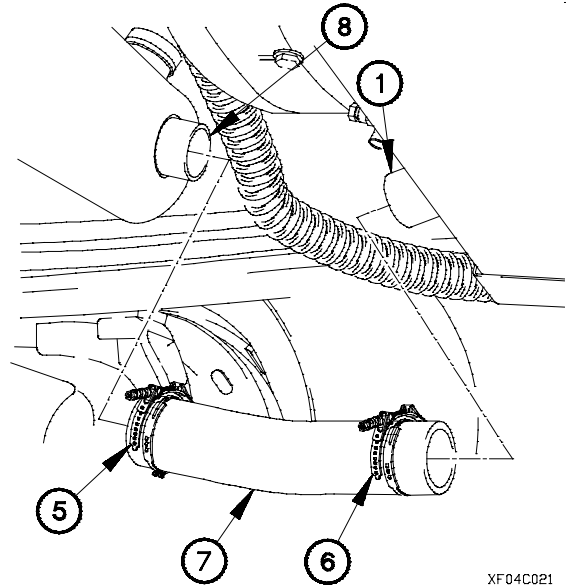

XF04C021

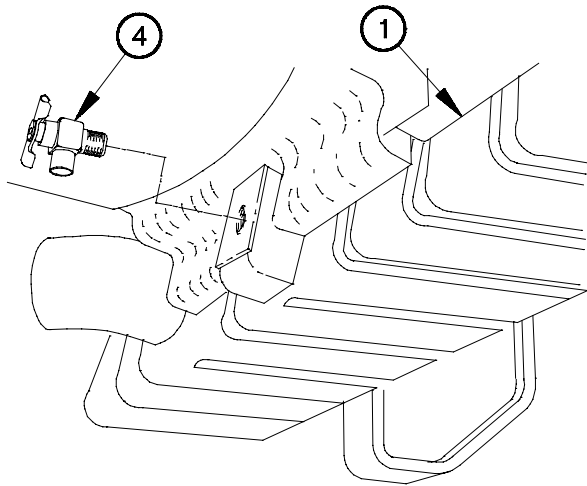

XF04C03A

- (7) Remove radiator draincock (4) from radiator (1).

- (8) Remove three self-locking nuts (9), six washers (10), and three screws (11) from left side of bottom radiator fan shroud (12). Discard self-locking nuts.

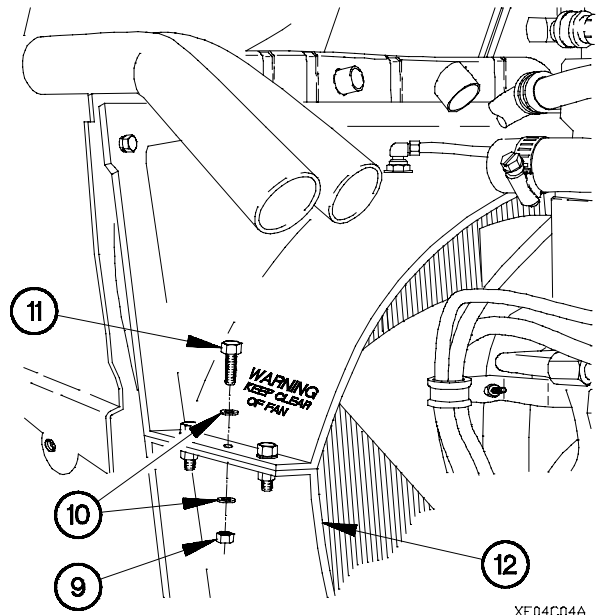

XF04C04A

6-4. RADIATOR FAN SHROUDS REPLACEMENT (CONT)

(9) Remove three self-locking nuts (13), six washers (14), three screws (15), clamp (16), and fan clutch hose (4) from right side of bottom radiator fan shroud (12). Discard self-locking nuts.

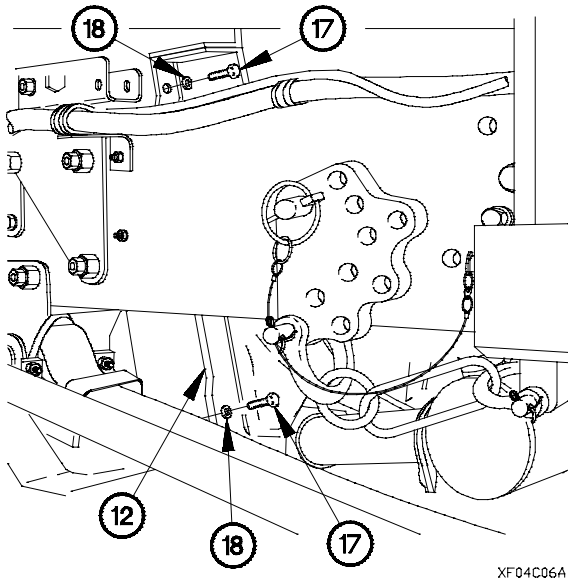
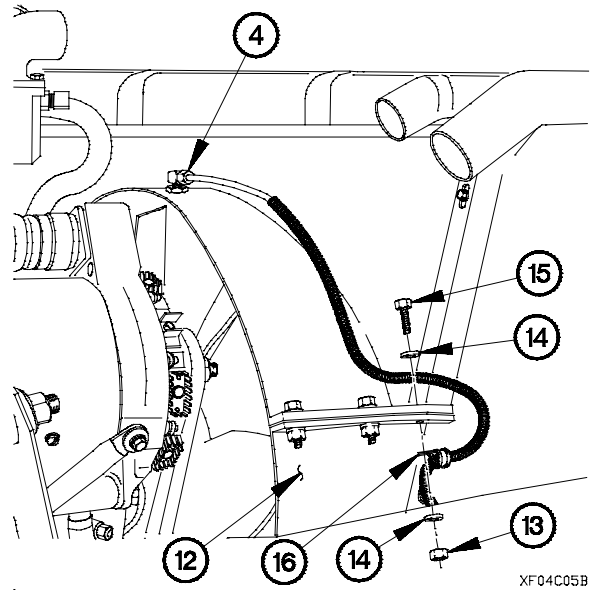

(10) Remove two screws (17) and washers (18) from each side of bottom radiator fan shroud (12).

(11) Remove bottom radiator fan shroud (12) and two engine airflow baffles (19).

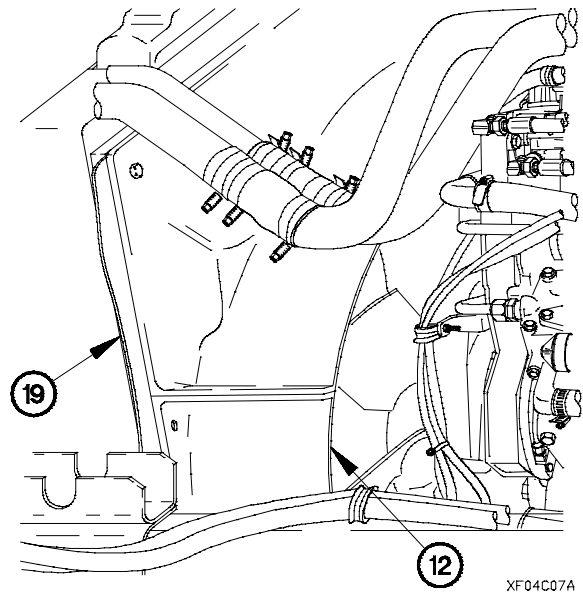

d. Bottom Radiator Fan Shroud Installation.

- (1) Position bottom radiator fan shroud (1) in mounting location.
- (2) Position two engine airflow baffles (2) between bottom radiator fan shroud (1) and radiator (3).

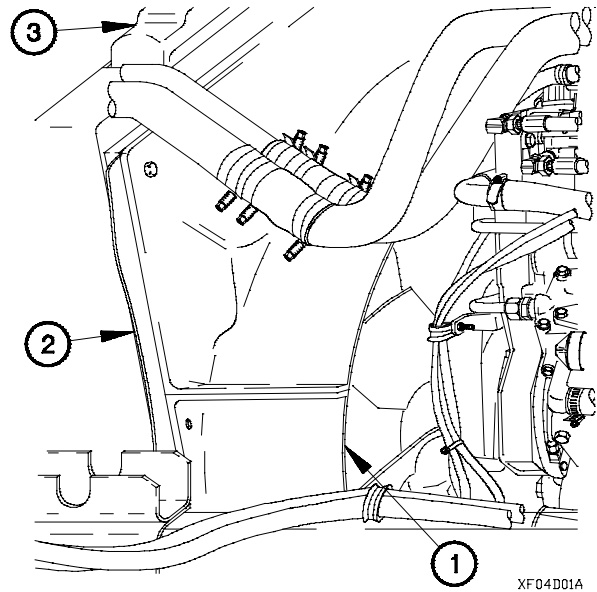

XF04D01A

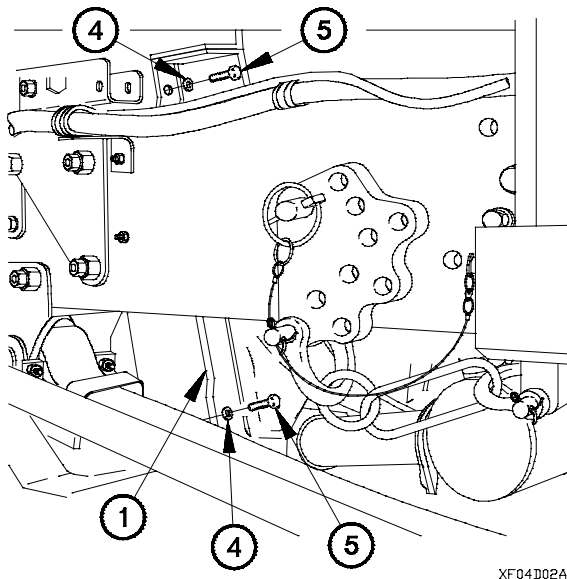

XF04D02A

WARNING

Adhesives, solvents, and sealing compounds can burn easily, can give off harmful vapors, and are harmful to skin and clothing. To avoid injury or death, keep away from open fire and use in a well-ventilated area. If adhesive, solvent, or sealing compound gets on skin or clothing, wash immediately with soap and water. Failure to comply may result in injury to personnel.

- (3) Apply sealing compound to threads of four screws (5).
- (4) Position two washers (4) and screws (5) in each side of bottom radiator fan shroud (1).

6-4. RADIATOR FAN SHROUDS REPLACEMENT (CONT)

- (5) Position six washers (6), three screws (7), and self-locking nuts (8) on left side of bottom radiator fan shroud (1).
- (6) Tighten three self-locking nuts (8) to 84-108 lb-in. (10-12 N-m).

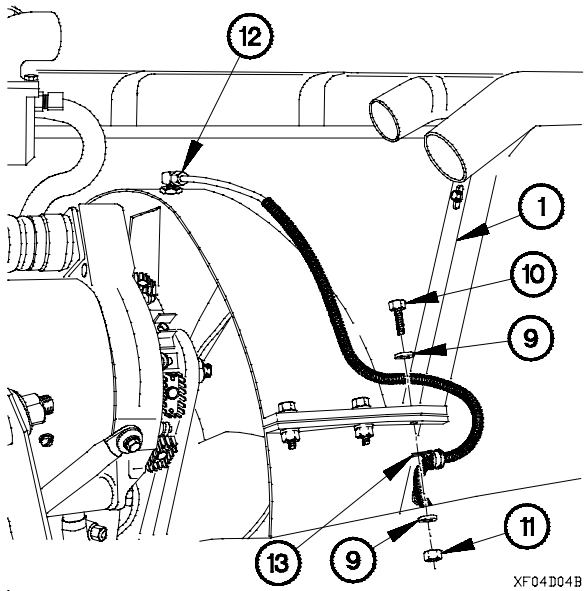
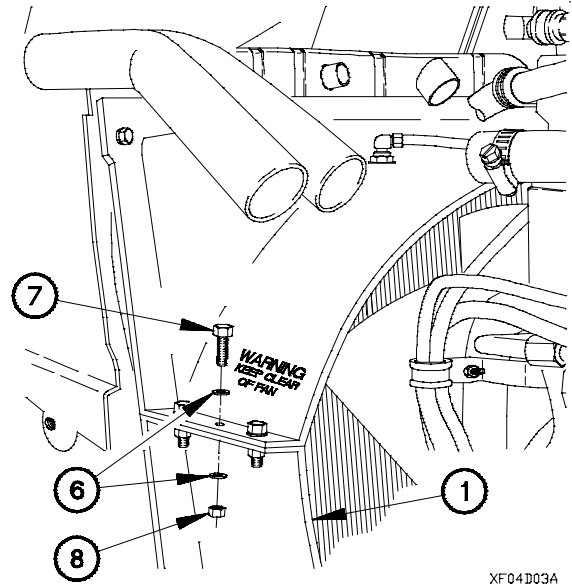

- (7) Position six washers (9), three screws (10), self-locking nuts (11), fan clutch hose (12), and clamp (13) on right side of bottom radiator fan shroud (1).
- (8) Tighten three self-locking nuts (11) to 84-108 lb-in. (10-12 N-m).

- (9) Tighten two screws (5) on each side of bottom radiator fan shroud (1) to 84-108 lb-in (10-12 N-m).

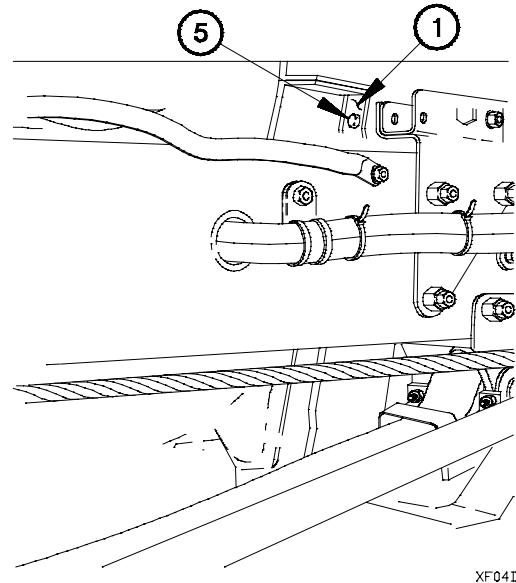

WARNING

Adhesives, solvents, and sealing compounds can burn easily, can give off harmful vapors, and are harmful to skin and clothing. Keep away from open fire and use in a well ventilated area. If adhesive, solvent, or sealing compound gets on skin or clothing, wash immediately with soap and water. Failure to comply may result in injury to personnel.

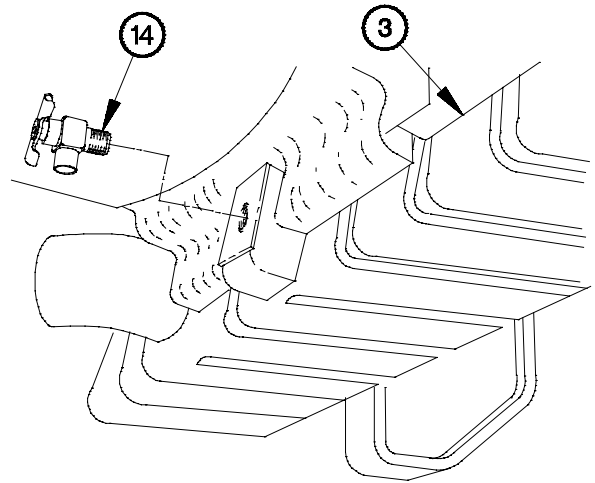

(10) Apply antiseize compound to threads of radiator draincock (14).

(11) Install radiator draincock (14) in radiator (3).

XF04D06B

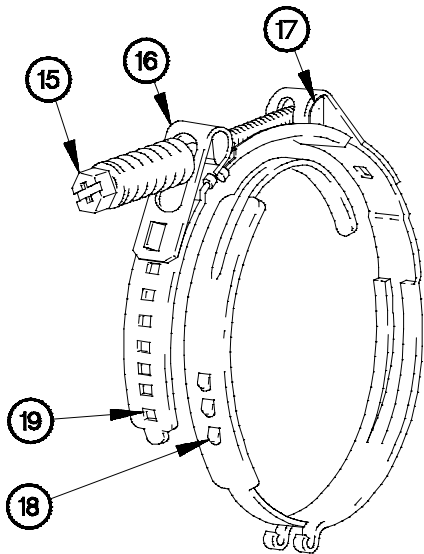

(12) Loosen two screws (15) in clamps (16) as far as possible without disengaging screws from D-nuts (17).

(13) Unhook clamp tabs (18) from tab windows (19).

XF04D07B

CAUTION

- Clamp tongue must be started in clamp groove. Failure to comply may result in damage to equipment.
- Position clamps so that screws will be toward center of vehicle and angled down.

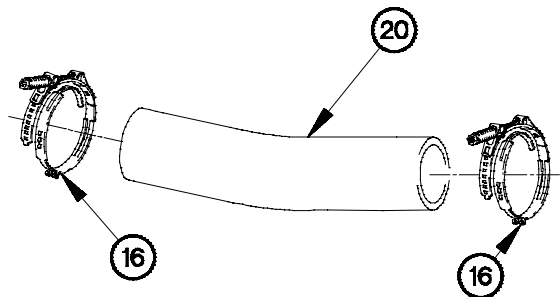

XF04D08B

(14) Position two clamps (16) on lower coolant hose (20).

6-4. RADIATOR FAN SHROUDS REPLACEMENT (CONT)

- (15) Install lower coolant hose (20) between radiator (3) and transmission oil cooler (21).
- (16) Engage as many clamp tabs (18) as possible in tab windows (19) allowing little or no play between clamps (16) and lower coolant hose (20).
- (17) Tighten two clamps (16) to 12-18 lb-in. (1-2 N·m).

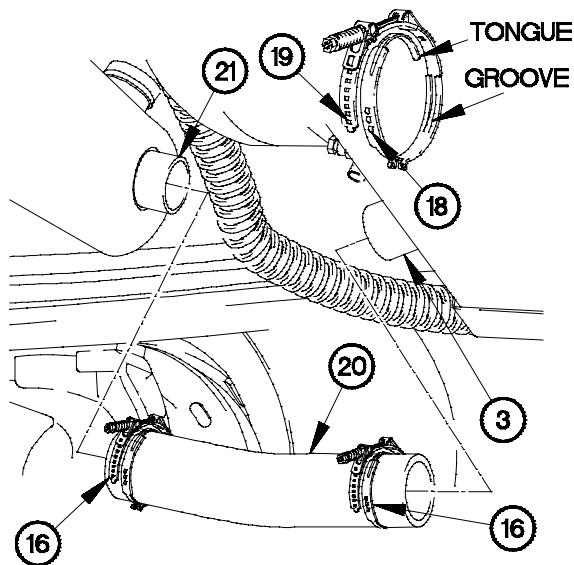

XF04D09B

NOTE

Minimum allowable gap on clamp is 0.2 in. (5 mm). If gap is less than 0.2 in. (5 mm), remove and re-install clamp.

- (18) Measure gap on two clamps (16).

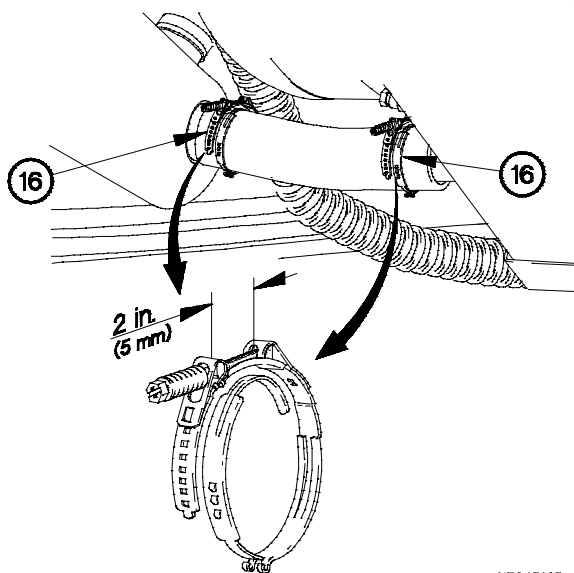

XF04D10B

e. Follow-On Maintenance.

- (1) Install upper coolant tube and hoses (para 6-9).
- (2) Install charge air cooler to air inlet elbow tubes/hoses (para 4-5).
- (3) Install turbocharger to charge air cooler tube/hoses (para 4-4).
- (4) Add coolant to radiator overflow tank (TM 9-2320-365-10).
- (5) Check for coolant leaks under vehicle.
- (6) Start engine (TM 9-2320-365-10).
- (7) Check for coolant leaks under vehicle.

- (8) Check coolant level after normal operating temperature is reached. Add coolant as required.
- (9) Install radiator cap on radiator overflow tank.
- (10) Check for coolant leaks under vehicle.
- (11) Raise cab (TM 9-2320-365-10).
- (12) Check for coolant leaks in engine compartment.
- (13) Check to make sure engine fan does not contact fan shroud.
- (14) Lower cab (TM 9-2320-365-10).
- (15) Shut down engine (TM 9-2320-365-10).

End of Task.

6-5. THERMOSTAT REPLACEMENT

This task covers:

- a. Removal
- b. Installation
- c. Follow-On Maintenance

INITIAL SETUP

Equipment Conditions

- Engine shut down (TM 9-2320-366-10-1).
- Cab raised (TM 9-2320-366-10-1).

Tools and Special Tools

- Tool Kit, Genl Mech (Item 46, Appendix C)
- Pan, Drain (Item 24, Appendix C)

Tools and Special Tools (Cont)

- Goggles, Industrial (Item 15, Appendix C)
- Gloves, Rubber (Item 13, Appendix C)

Materials/Parts

- Adhesive (Item 5, Appendix D)
- Gasket and Preformed Packing Set (Item 43.1, Appendix G)

a. Removal.

- (1) Position drain pan under thermostat housing (1).
- (2) Remove two screws (2) and washers (3) from outlet housing (4).
- (3) Remove outlet housing (4) from thermostat housing (1).
- (4) Remove thermostat (5) from thermostat housing (1).
- (5) Remove thermostat gasket (6) from thermostat housing (1). Discard thermostat gasket.
- (6) Remove thermostat gasket debris from outlet housing (4) and thermostat housing (1).

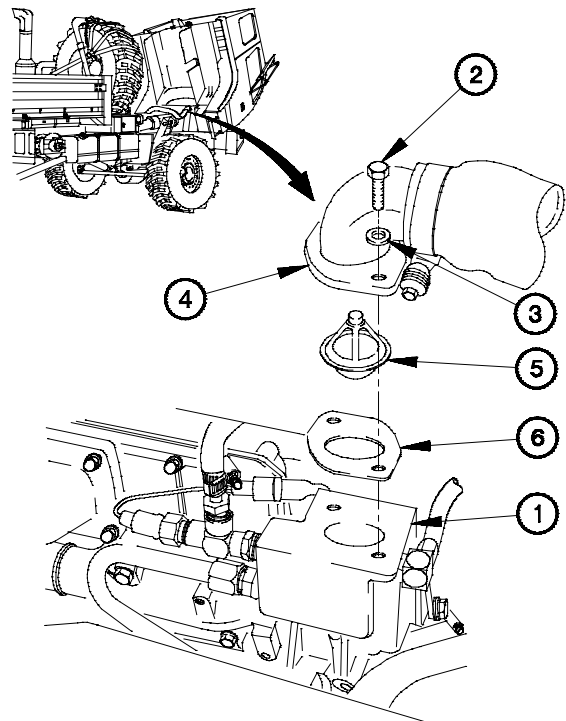

XF05R01A

6-5. THERMOSTAT REPLACEMENT (CONT)

b. Installation.

WARNING

Adhesives, solvents, and sealing compounds can burn easily, can give off harmful vapors, and are harmful to skin and clothing. Keep away from open fire and use in a well-ventilated area. If adhesive, solvent, or sealing compound gets on skin or clothing, wash immediately with soap and water. Failure to comply may result in injury to personnel.

- (1) Apply adhesive to thermostat housing surface (1).
- (2) Position thermostat gasket (2) on thermostat housing (1).
- (3) Install thermostat (3) with long end up.
- (4) Apply adhesive to outlet housing (4) mating surface.
- (5) Install outlet housing (4) on thermostat housing (1) with two washers (5) and screws (6).

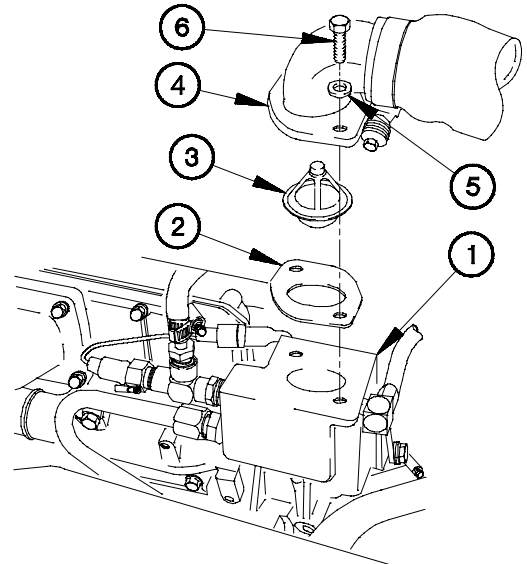

XF05I01A

c. Follow-On Maintenance.

- (1) Lower cab (TM 9-2320-366-10-1).
- (2) Add coolant to radiator overflow tank (TM 9-2320-366-10-2).
- (3) Check for coolant leaks under vehicle.
- (4) Start engine (TM 9-2320-366-10-1).
- (5) Check coolant level after normal operating temperature is reached. Add coolant as required (TM 9-2320-366-10-2).
- (6) Raise cab (TM 9-2320-366-10-1).

- (7) Check thermostat housing for coolant leaks.
- (8) Install radiator cap on radiator overflow tank.
- (9) Lower cab (TM 9-2320-366-10-1).
- (10) Shut down engine (TM 9-2320-366-10-1).

End of Task.

6-6. THERMOSTAT HOUSING REPLACEMENT

This task covers:

- a. Removal
- b. Installation
- c. Follow-On Maintenance

INITIAL SETUP

Equipment Conditions

Thermostat removed (para 6-5).

Tools and Special Tools

Tool Kit, Genl Mech (Item 46, Appendix C)
 Pan, Drain (Item 24, Appendix C)
 Goggles, Industrial (Item 15, Appendix C)
 Gloves, Rubber (Item 13, Appendix C)

Materials/Parts

Antiseize Compound (Item 58, Appendix D)
 Antifreeze, Ethylene Glycol, Permanent (Item 12, Appendix D)
 Adhesive (Item 5, Appendix D)
 Packing, Preformed (Item 201, Appendix G)

a. Removal.

- (1) Position drain pan under thermostat housing (1).
- (2) Disconnect heater tube (2) from fitting (3).
- (3) Loosen hose clamp (4) on radiator fill hose (5).
- (4) Disconnect radiator fill hose (5) from fitting (6).
- (5) Disconnect connector clamp (7) from water temperature transducer connector (8).
- (6) Disconnect water temperature transducer connector (8) from connector P41 (9).
- (7) Remove water temperature transducer (10) from tee fitting (11).

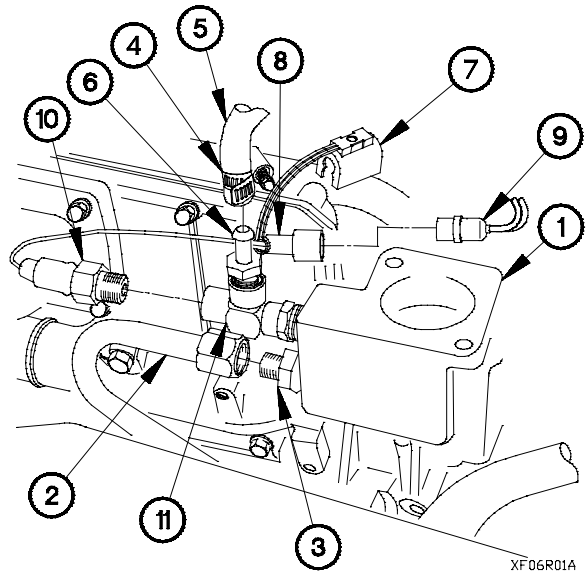

XF06R01A

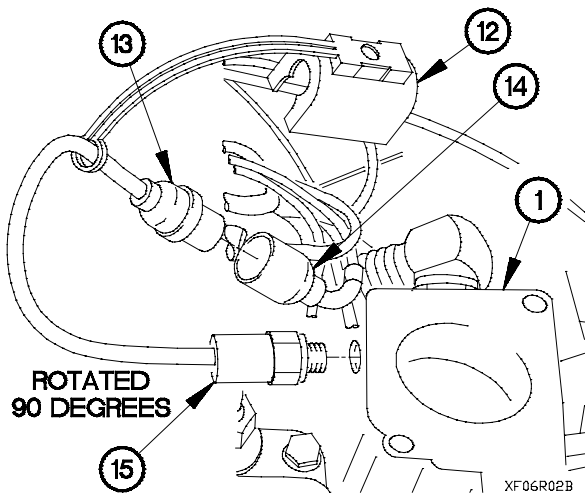

XF06R02B

- (8) Disconnect connector clamp (12) from water temperature light switch connector (13).
- (9) Disconnect water temperature light switch connector (13) from connector P37 (14).
- (10) Remove water temperature light switch (15) from thermostat housing (1).

- (11) Loosen hose clamp (16) on transmission oil cooler hose (17).
- (12) Disconnect transmission oil cooler hose (17) from thermostat housing (1).
- (13) Disconnect compressor inlet coolant tube (18) from 90-degree fitting (19).

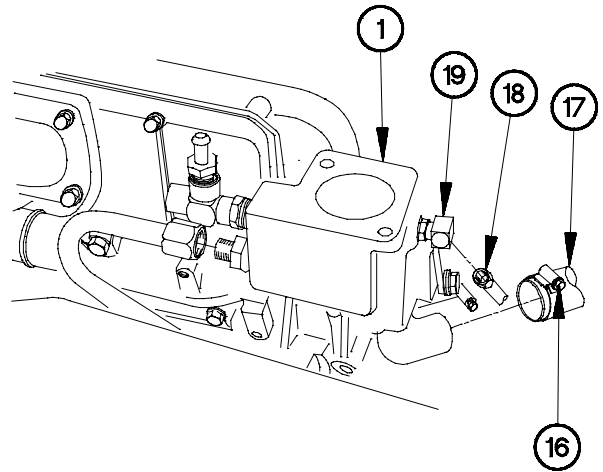

XF06R03-

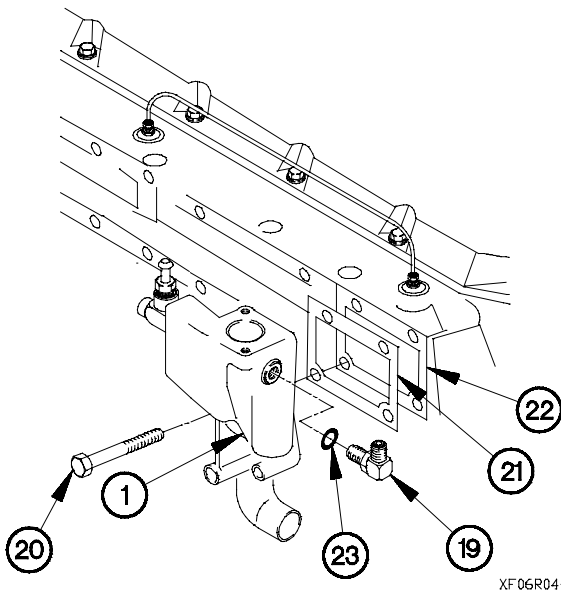

XF06R04-

- (14) Remove two screws (20) from thermostat housing (1).
- (15) Remove thermostat housing (1) and gasket (21) from engine block (22). Discard gasket.
- (16) Remove 90-degree fitting (19) from thermostat housing (1).
- (17) Remove preformed packing (23) from 90-degree fitting (19). Discard preformed packing.
- (18) Remove gasket debris from thermostat housing (1).

- (19) Remove tee fitting (11) from thermostat housing (1).
- (20) Remove fitting (6) from tee fitting (11).
- (21) Remove fitting (24) from thermostat housing (1).

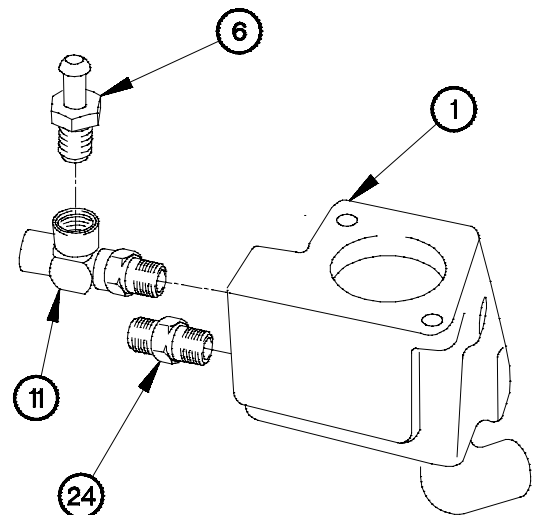

XF06R051

6-6. THERMOSTAT HOUSING REPLACEMENT (CONT)

b. Installation.

WARNING

Adhesives, solvents, and sealing compounds can burn easily, can give off harmful vapors, and are harmful to skin and clothing. Keep away from open fire and use in a well-ventilated area. If adhesive, solvent, or sealing compound gets on skin or clothing, wash with soap and water. Failure to comply may result in injury to personnel.

- (1) Apply adhesive to threads of tee fitting (1) and fittings (2 and 3).
- (2) Install fitting (2) in tee fitting (1).
- (3) Install tee fitting (1) in thermostat housing (4).
- (4) Install fitting (3) in thermostat housing (4).

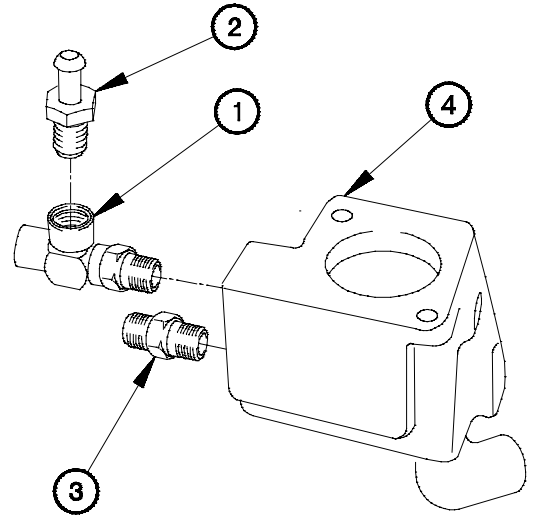

XF061011

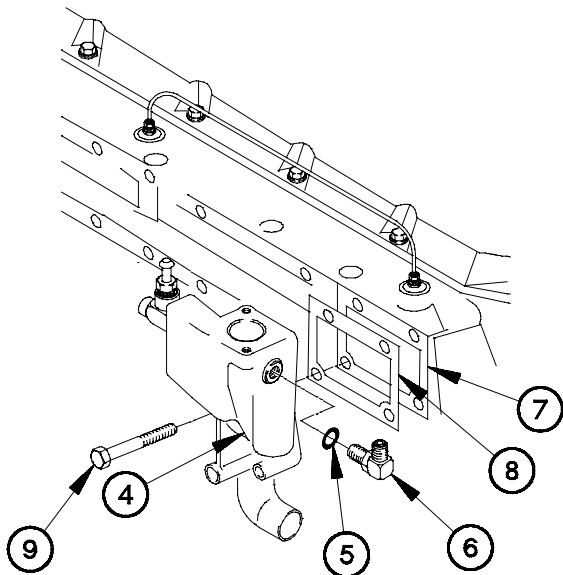

XF06102A

- (5) Install preformed packing (5) on 90-degree fitting (6).
- (6) Install 90-degree fitting (6) in thermostat housing (4).
- (7) Apply adhesive to surfaces of thermostat housing (4) and engine block (7).
- (8) Position gasket (8) on engine block (7).
- (9) Install thermostat housing (4) on engine block (7) with two screws (9).

- (10) Connect compressor inlet coolant tube (10) to 90-degree fitting (6).
- (11) Install transmission oil cooler hose (11) on thermostat housing (4) with hose clamp (12).

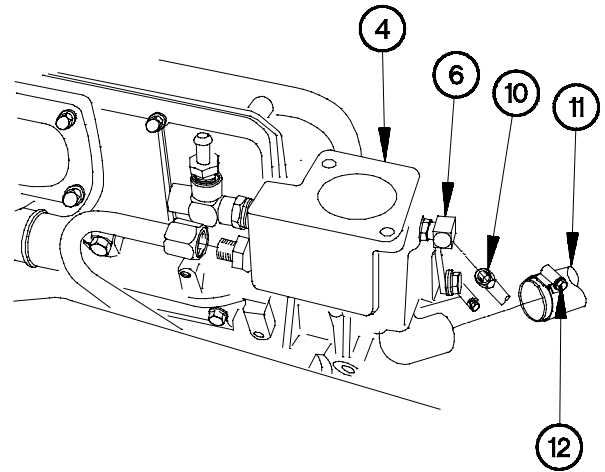

XF06I03A

WARNING

Adhesives, solvents, and sealing compounds can burn easily, can give off harmful vapors, and are harmful to skin and clothing. Keep away from open fire and use in a well-ventilated area. If adhesive, solvent, or sealing compound gets on skin or clothing, wash with soap and water. Failure to comply may result in injury to personnel.

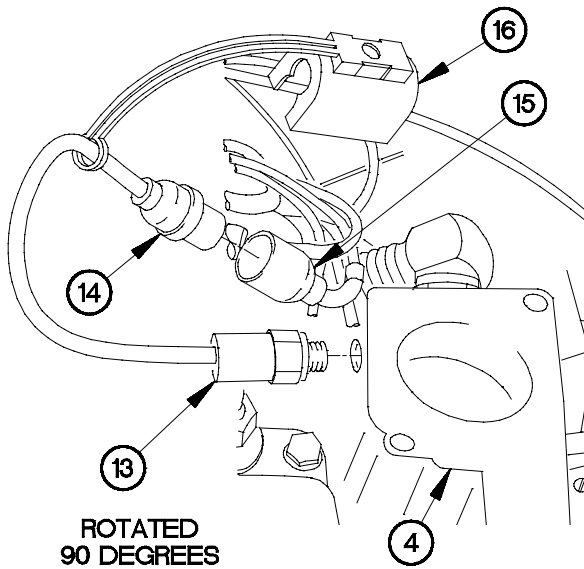

XF06I04A

- (12) Apply antiseize compound to threads of water temperature light switch (13).
- (13) Install water temperature light switch (13) in thermostat housing (4).
- (14) Connect water temperature light switch connector (14) to connector P37 (15).
- (15) Connect connector clamp (16) on water temperature light switch connector (14).

6-6. THERMOSTAT HOUSING REPLACEMENT (CONT)

WARNING

Adhesives, solvents, and sealing compounds can burn easily, can give off harmful vapors, and are harmful to skin and clothing. Keep away from open fire and use in a well-ventilated area. If adhesive, solvent, or sealing compound gets on skin or clothing, wash with soap and water. Failure to comply may result in injury to personnel.

- (16) Apply antiseize compound to threads of water temperature transducer (17).
- (17) Install water temperature transducer (17) in tee fitting (1).
- (18) Connect water temperature transducer connector (18) to connector P41 (19).
- (19) Connect connector clamp (20) on water temperature transducer connector (18).
- (20) Install radiator fill hose (21) on fitting (2) with hose clamp (22).
- (21) Connect heater tube (23) to fitting (2).

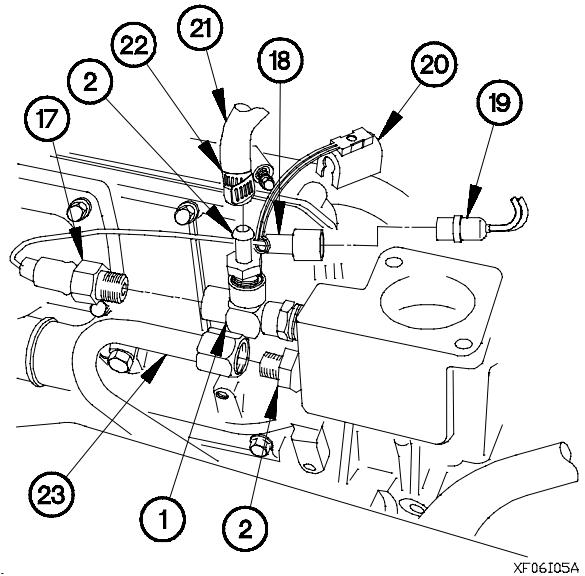

XF06105A

c. Follow-On Maintenance.

- (1) Install thermostat (para 6-5).
- (2) Add coolant to radiator overflow tank (TM 9-2320-366-10-2).
- (3) Lower cab (TM 9-2320-366-10-1).
- (4) Start engine (TM 9-2320-366-10-1).
- (5) Check for coolant leaks under vehicle.
- (6) Check coolant level after normal operating temperature is reached. Add coolant as required (TM 9-2320-366-10-2).
- (7) Check for coolant leaks under vehicle.

- (8) Raise cab (TM 9-2320-366-10-1).
- (9) Check for coolant leaks at thermostat housing.
- (10) Lower cab (TM 9-2320-366-10-1).
- (11) Shut down engine (TM 9-2320-366-10-1).

End of Task.

6-7. COOLANT BYPASS TUBE REPLACEMENT	
This task covers:	
a. Removal b. Installation	c. Follow-On Maintenance
INITIAL SETUP	
<p>Equipment Conditions Engine shut down (TM 9-2320-366-10-1). Cab raised (TM 9-2320-366-10-1). Batteries disconnected (para 7-57).</p> <p>Tools and Special Tools Goggles, Industrial (Item 15, Appendix C) Container (52 qt (50 L) capacity) Tool Kit, Genl Mech (Item 46, Appendix C) Wrench, Torque, 0-75 lb-in. (Item 90, Appendix B)</p>	<p>Materials/Parts Antiseize Compound (Item 58, Appendix D) Antifreeze, Ethylene Glycol, Permanent (Item 12, Appendix D) Nut, Self-Locking (Item 128, Appendix G)</p>

WARNING

- Coolant may be very hot and under pressure from engine operation. Ensure engine is cool before performing maintenance. Failure to comply may result in injury to personnel.
- Wear appropriate eye protection when working under vehicle due to the possibility of falling debris. Failure to comply may result in injury to personnel.

a. Removal.

- (1) Remove radiator cap (1) from radiator overflow tank (2).
- (2) Position container under radiator (3).
- (3) Open radiator draincock (4) and drain coolant.
- (4) Close radiator draincock (4).

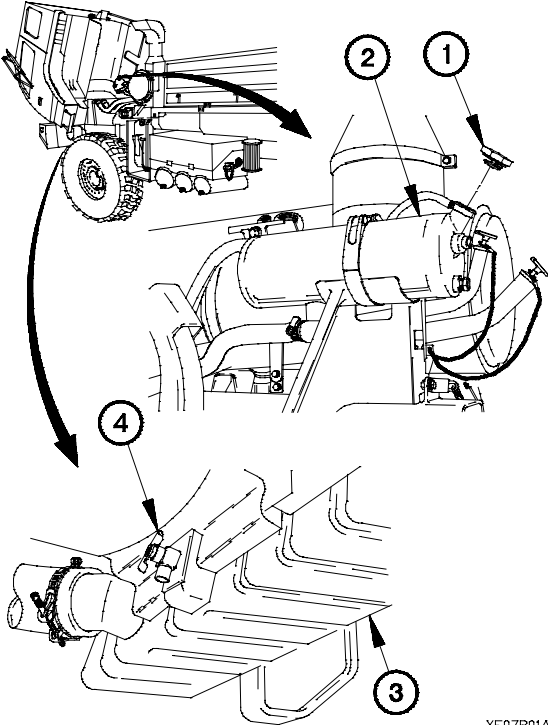

XF07R01A

- (5) Remove self-locking nut (5), washer (6), screw (7), and clamp (8) from bracket (9). Discard self-locking nut.
- (6) Remove clamp (8) from coolant bypass tube (10).

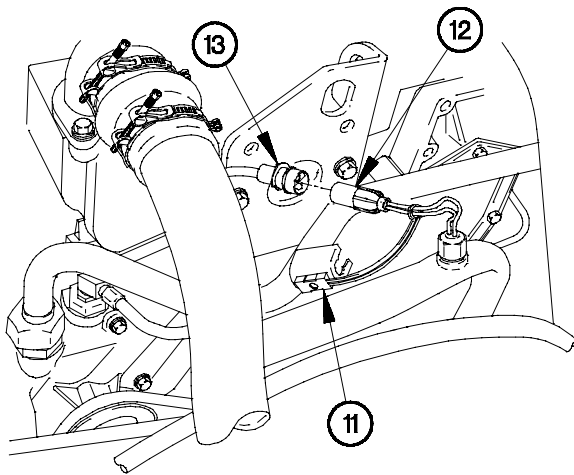
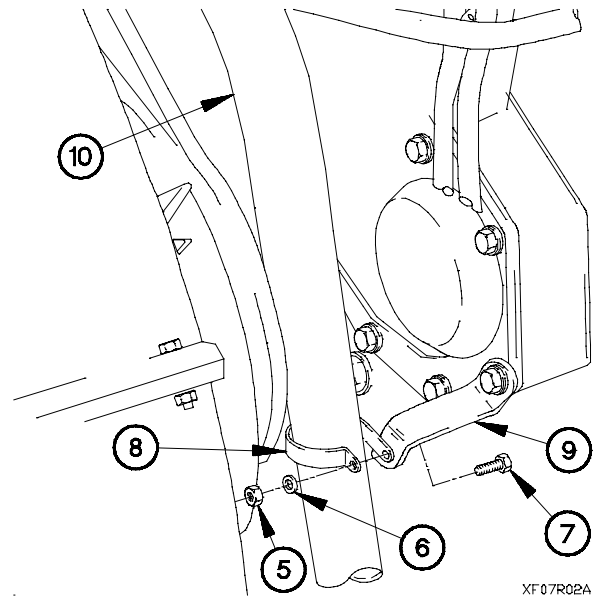

- (7) Disconnect connector clamp (11) from ether sensor connector (12).
- (8) Disconnect ether sensor connector (12) from connector P42 (13).

- (9) Loosen two clamps (14) on coolant hose (15).
- (10) Remove coolant hose (15) and flow restrictor (16) from transmission oil cooler (17).
- (11) Remove coolant hose (15) and two clamps (14) from coolant bypass tube (10).

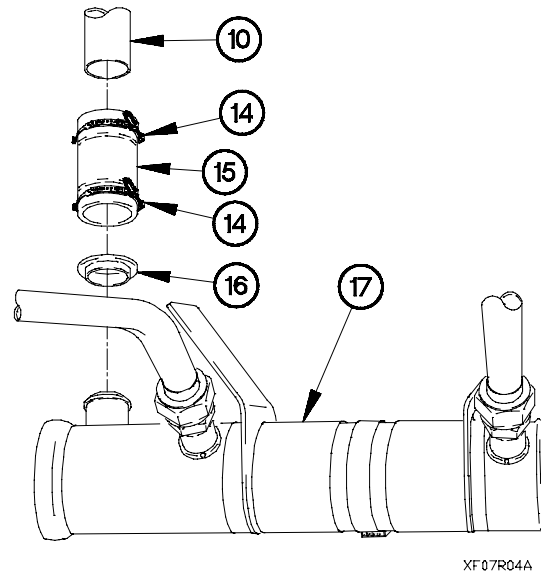

6-7. COOLANT BYPASS TUBE REPLACEMENT (CONT)

- (12) Loosen two clamps (18) on coolant hose (19).
- (13) Remove coolant bypass tube (10) from coolant hose (19).
- (14) Remove coolant hose (19) from thermostat housing (20).

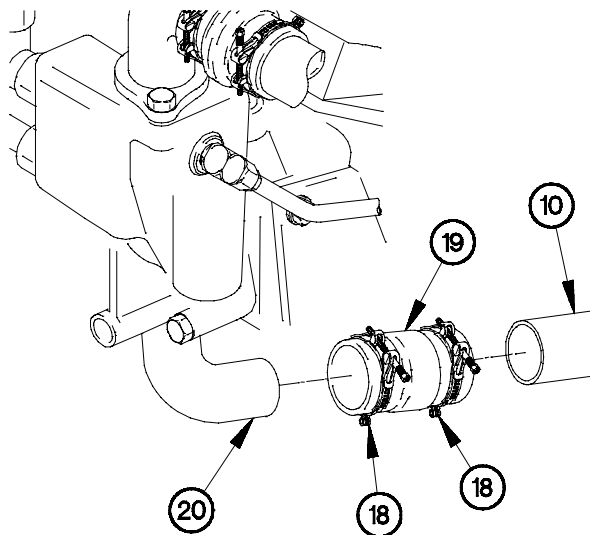

XF 07R05A

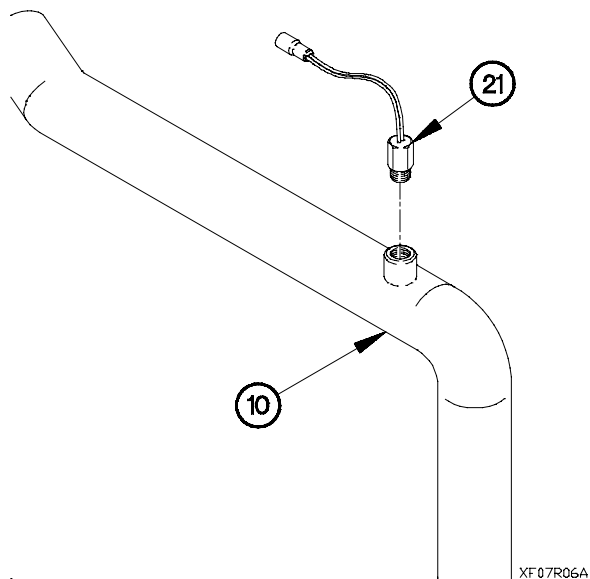

- (15) Remove ether sensor (21) from coolant bypass tube (10).

XF 07R06A

b. Installation.

WARNING

Adhesives, solvents, and sealing compounds can burn easily, can give off harmful vapors, and are harmful to skin and clothing. Keep away from open fire and use in a well-ventilated area. If adhesive, solvent, or sealing compound gets on skin or clothing, wash immediately with soap and water. Failure to comply may result in injury to personnel.

- (1) Apply antiseize compound to threads of ether sensor (1).
- (2) Install ether sensor (1) in coolant bypass tube (2).

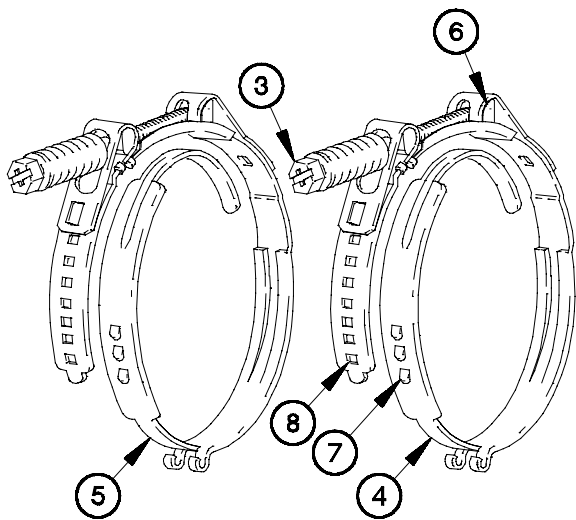
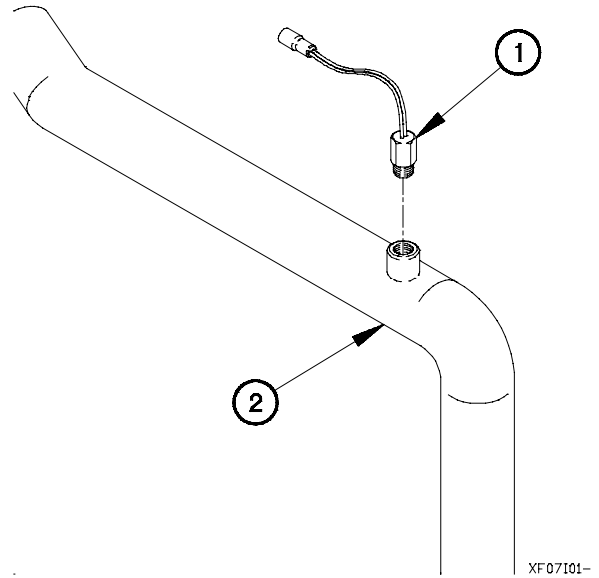

NOTE

Both coolant hoses are assembled the same way. Only one shown.

- (3) Loosen two screws (3) in clamps (4) and clamps (5) as far as possible without disengaging screws from D-nuts (6).
- (4) Unhook clamp tabs (7) from tab windows (8).

6-7. COOLANT BYPASS TUBE REPLACEMENT (CONT)

CAUTION

Clamp tongue must be started in clamp groove. Failure to comply may result in damage to equipment.

- (5) Position two clamps (4) on coolant hose (9).
- (6) Position two clamps (5) on coolant hose (10).

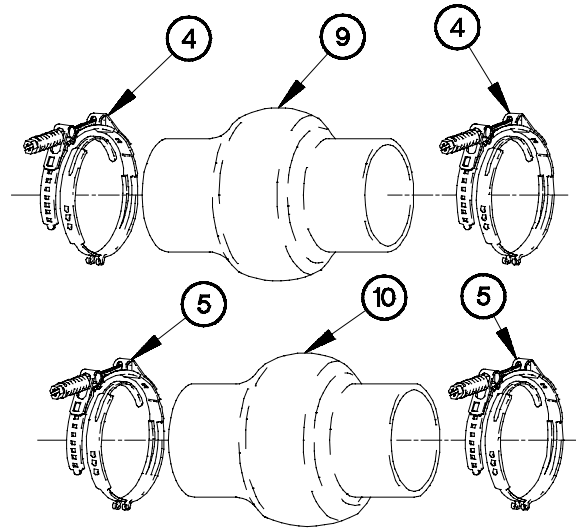

XF07I03A*

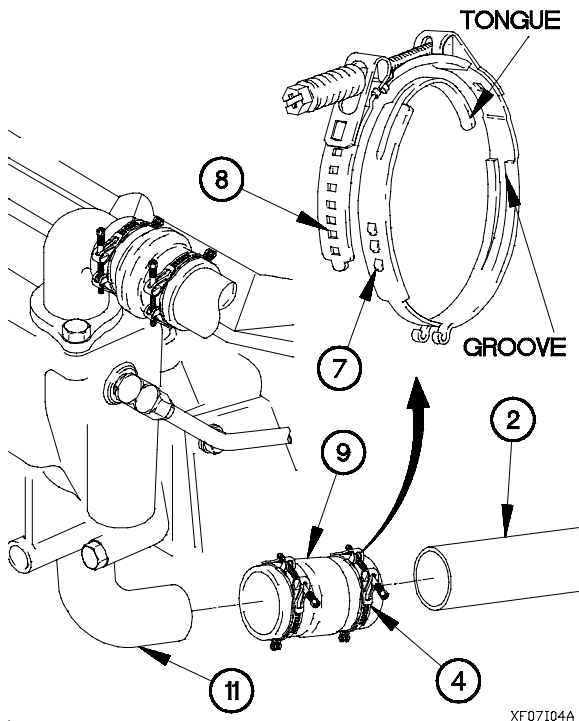

XF07I04A

- (7) Position coolant hose (9) on thermostat housing (11).
- (8) Position coolant bypass tube (2) in coolant hose (9).
- (9) Engage as many clamp tabs (7) as possible in tab windows (8) allowing little or no play between two clamps (4) and coolant hose (9).

- (10) Position coolant hose (10) on coolant bypass tube (2).
- (11) Position flow restrictor (12) and coolant hose (10) on transmission oil cooler (13).
- (12) Engage as many clamp tabs (7) as possible in tab windows (8) allowing little or no play between two clamps (5) and coolant hose (10).
- (13) Tighten two clamps (5) to 12-18 lb-in. (1-2 N·m).

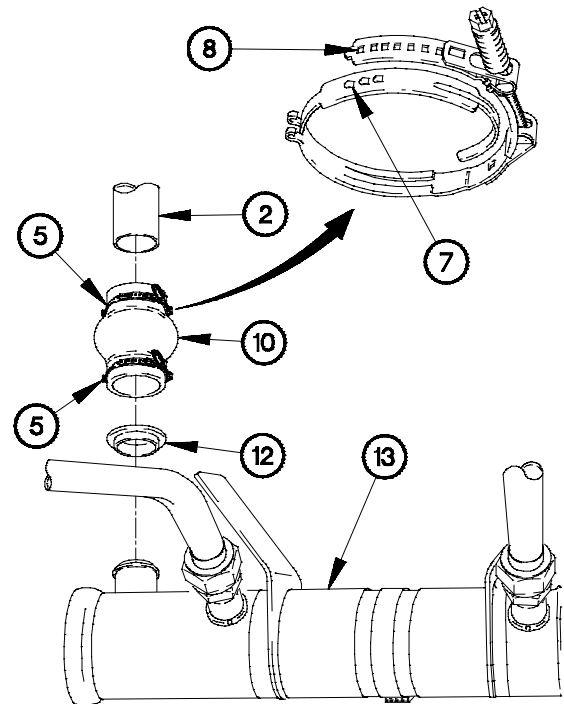

XF07105A

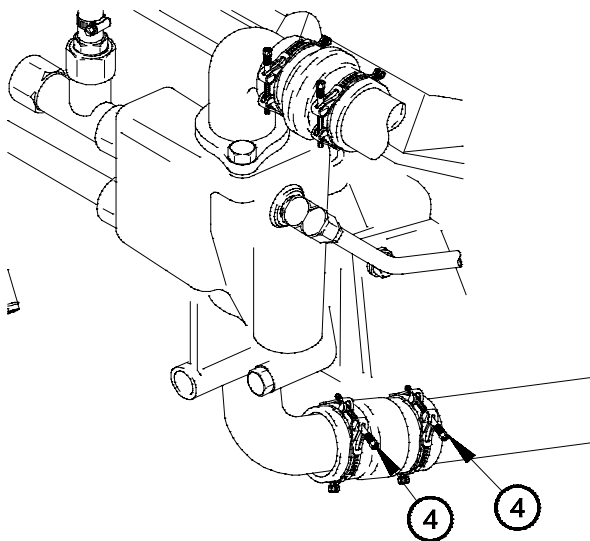

XF07106A

- (14) Tighten two clamps (4) to 12-18 lb-in. (1-2 N·m).

NOTE

Minimum allowable gap on clamp is 0.2 in. (5 mm). If gap is less than 0.2 in. (5 mm), remove and re-install clamp.

- (15) Measure gap on two clamps (5).

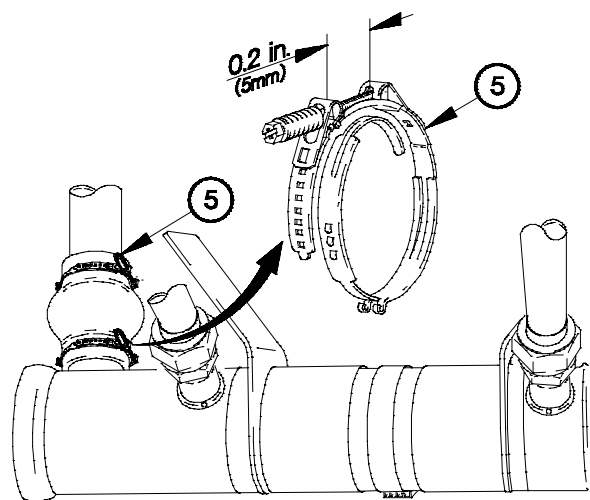

XF07107B

6-7. COOLANT BYPASS TUBE REPLACEMENT (CONT)

(16) Measure gap on two clamps (4).

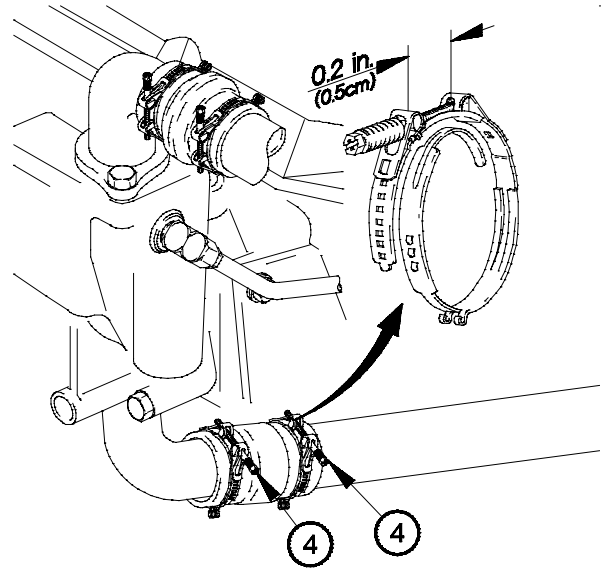

XF07I081

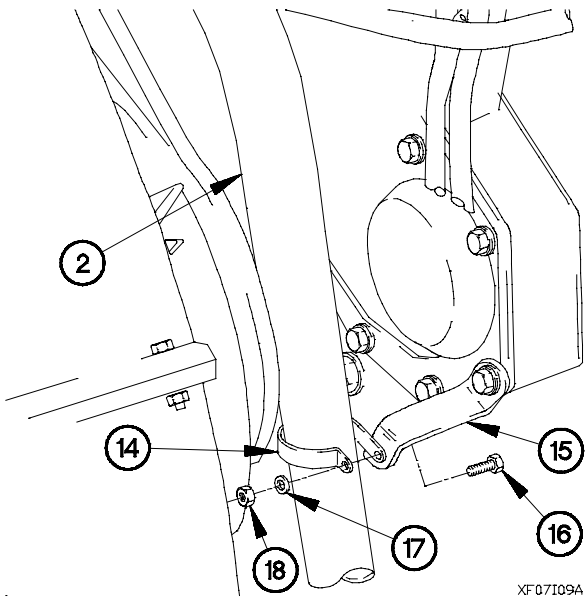

XF07I09A

(17) Install clamp (14) on coolant bypass tube (2).

(18) Install clamp (14) on bracket (15) with screw (16), washer (17), and self-locking nut (18).

(19) Connect connector P42 (19) to ether sensor connector (20).

(20) Connect connector clamp (21) on ether sensor connector (20).

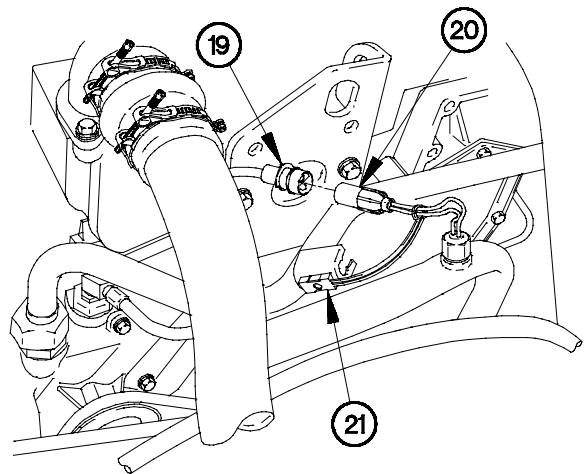

XF07I10A

c. Follow-On Maintenance.

- (1) Connect batteries (para 7-57).
- (2) Add coolant to radiator overflow tank (TM 9-2320-366-10-2).
- (3) Lower cab (TM 9-2320-366-10-1).
- (4) Start engine (TM 9-2320-366-10-1).
- (5) Check for coolant leaks under vehicle.
- (6) Check coolant level after normal operating temperature is reached. Add coolant as required (TM 9-2320-366-10-2).
- (7) Install radiator cap on radiator overflow tank.
- (8) Check for coolant leaks under vehicle.
- (9) Raise cab (TM 9-2320-366-10-1).
- (10) Check around transmission oil cooler, thermostat, and coolant bypass tube for coolant leaks.
- (11) Lower cab (TM 9-2320-366-10-1).
- (12) Shut down engine (TM 9-2320-366-10-1).

End of Task.

6-8. PERSONNEL HEATER HOSES REPLACEMENT	
This task covers:	
a. Removal b. Installation	c. Follow-On Maintenance
INITIAL SETUP	
Equipment Conditions Engine shut down (TM 9-2320-366-10-1).	Tools and Special Tools (Cont) Wrench, Torque, 0-75 lb-in. (Item 90, Appendix B) Wrench, Torque, 0-200 lb-in. (Item 59, Appendix C) Socket Set, Socket Wrench (Item 36, Appendix C)
Tools and Special Tools Goggles, Industrial (Item 15, Appendix C) Container (10 gal (38 L) capacity) Tool Kit, Genl Mech (Item 46, Appendix C)	Materials/Parts Ties, Cable, Plastic (Item 69, Appendix D)

WARNING

Coolant may be very hot and under pressure from engine operation. Ensure engine is cool before performing maintenance. Failure to comply may result in injury to personnel.

a. Removal.

- (1) Remove radiator cap (1) from radiator overflow tank (2).

WARNING

Wear appropriate eye protection when working under vehicle due to the possibility of falling debris. Failure to comply may result in injury to personnel.

- (2) Position container under radiator draincock (3).
- (3) Open radiator draincock (3) and drain approximately five gallons (19 L) of coolant.
- (4) Close radiator draincock (3).

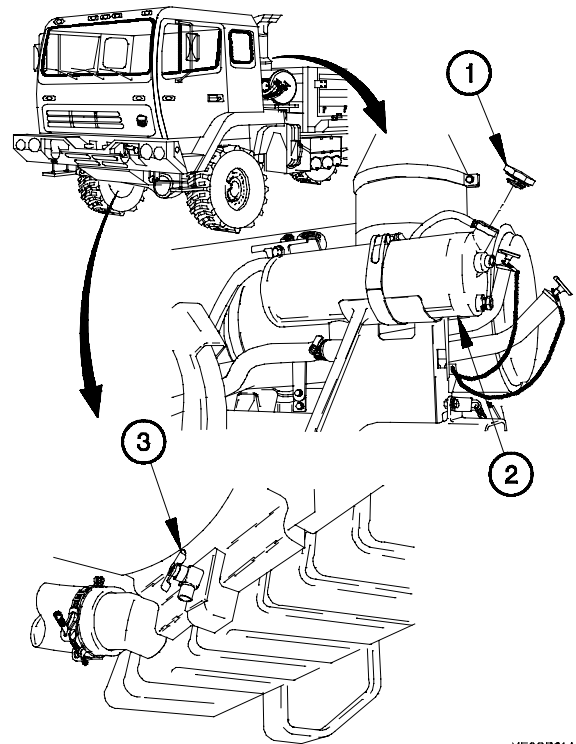

XF08R01A

NOTE

Remove plastic cable ties as required.

- (5) Remove two screws (4) and washers (5) from front grille (6).
- (6) Remove screw (7) and washer (8) from front grille (6).
- (7) Remove front grille (6) from cab (9).

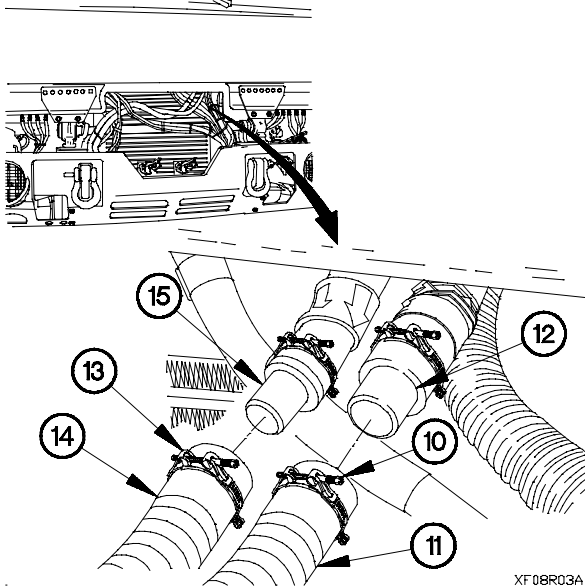
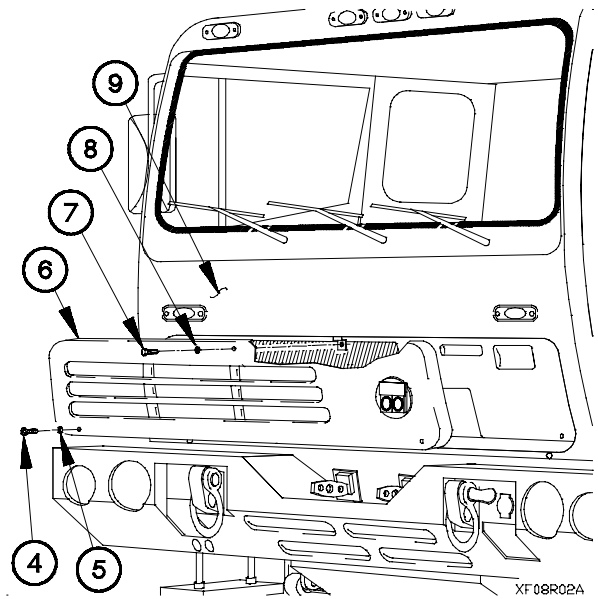

- (8) Loosen clamp (10) on heater inlet hose (11).
- (9) Remove heater inlet hose (11) from supply fitting (12).
- (10) Loosen clamp (13) on heater outlet hose (14).
- (11) Remove heater outlet hose (14) from return fitting (15).

- (12) Raise cab (TM 9-2320-366-10-1).
- (13) Loosen clamp (16) on heater inlet hose (11).
- (14) Remove heater inlet hose (11) from supply tube (17).

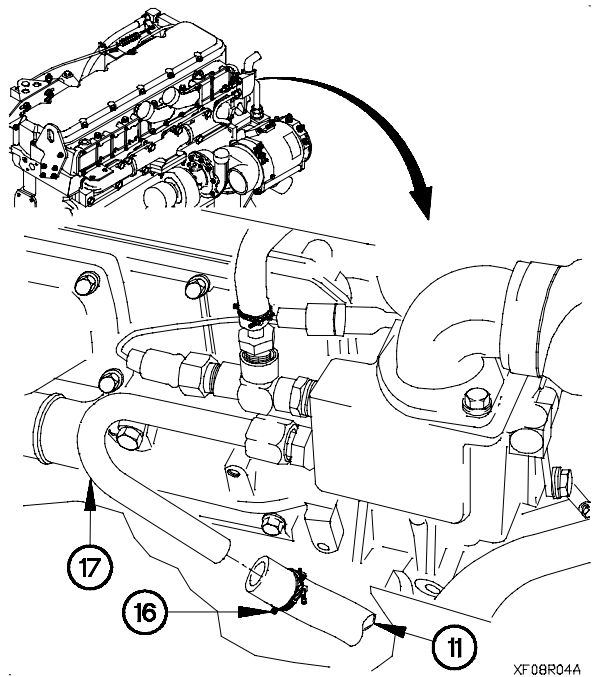

6-8. PERSONNEL HEATER HOSES REPLACEMENT (CONT)

- (15) Loosen clamp (18) on heater outlet hose (14).
- (16) Remove heater outlet hose (14) from return fitting (19).

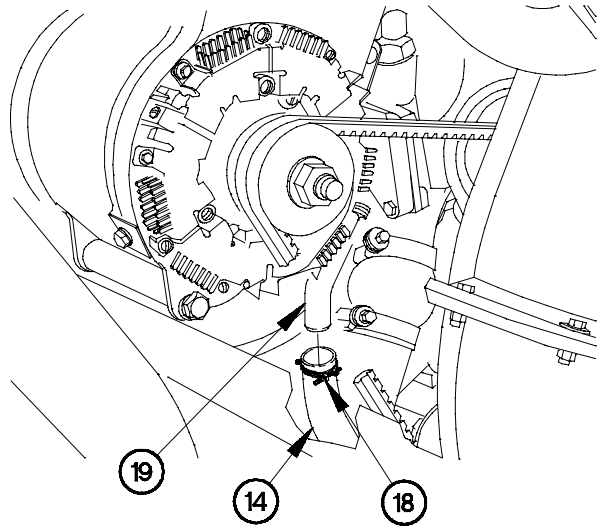

XF08R05A

b. Installation.

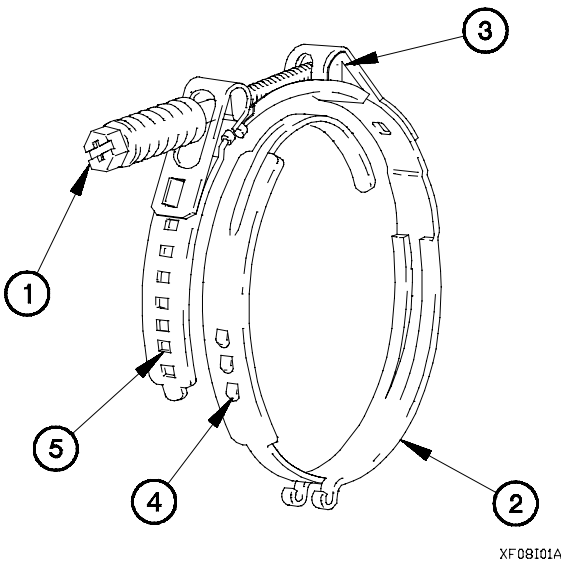

XF08I01A

- (1) Loosen four screws (1) in clamps (2) as far as possible without disengaging screws from D-nuts (3).
- (2) Unhook clamp tabs (4) from tab windows (5).

CAUTION

Clamp tongue must be started in clamp groove. Failure to comply may result in damage to equipment.

- (3) Position two clamps (2) on heater outlet hose (6).
- (4) Position two clamps (2) on heater inlet hose (7).

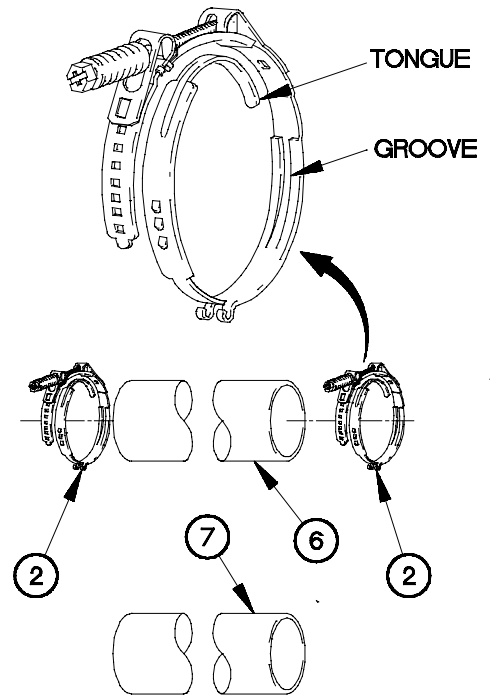

XF08I02A*

- (5) Position heater outlet hose (6) on return fitting (8).
- (6) Engage as many clamp tabs (4) as possible in tab windows (5) allowing little or no play between clamp (2) and heater outlet hose (6).
- (7) Tighten clamp (2) to 12-18 lb-in. (1-2 N·m).

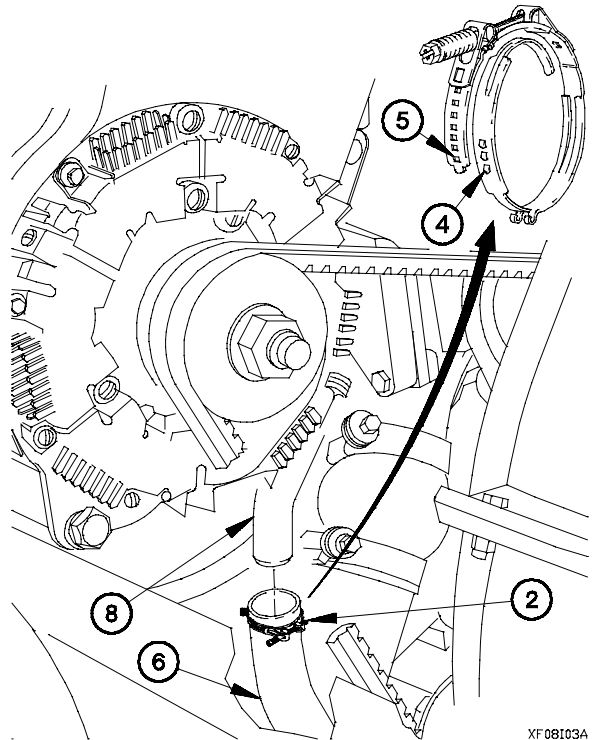

XF 08103A

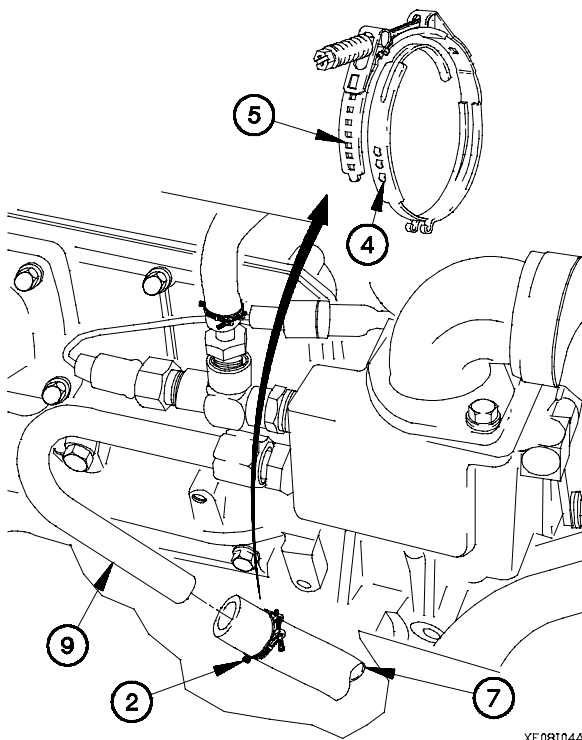

XF 08104A

- (8) Position heater inlet hose (7) on supply tube (9).
- (9) Engage as many clamp tabs (4) as possible in tab windows (5) allowing little or no play between clamp (2) and heater inlet hose (7).
- (10) Tighten clamp (2) to 12-18 lb-in. (1-2 N·m).

6-8. PERSONNEL HEATER HOSES REPLACEMENT (CONT)

(11) Lower cab (TM 9-2320-366-10-1).

NOTE

Heater outlet hose is marked with an arrow pointing down.

(12) Position heater outlet hose (6) on return fitting (10).

NOTE

Heater inlet hose is marked with an arrow pointing up.

(13) Position heater inlet hose (7) on supply fitting (11).

(14) Engage as many clamp tabs (4) as possible in tab windows (5) allowing little or no play between clamps (2) and heater outlet hose (6) and heater inlet hose (7).

(15) Tighten two clamps (2) to 12-18 lb-in. (1-2 N·m).

(16) Raise cab (TM 9-2320-366-10-1).

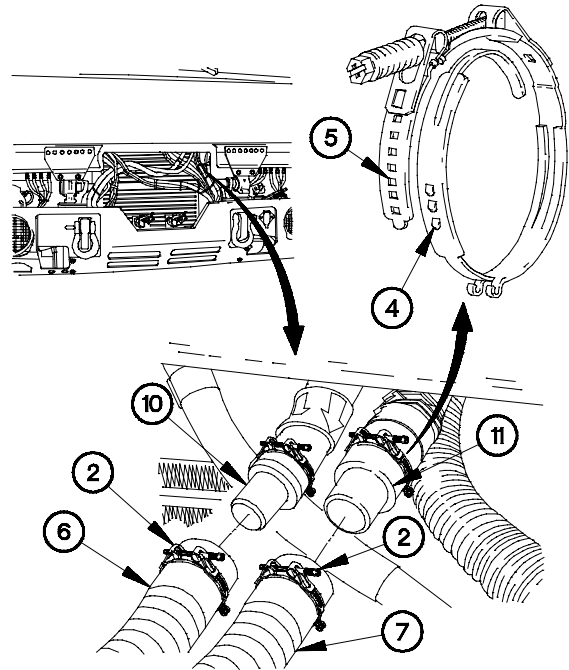

XF08105A

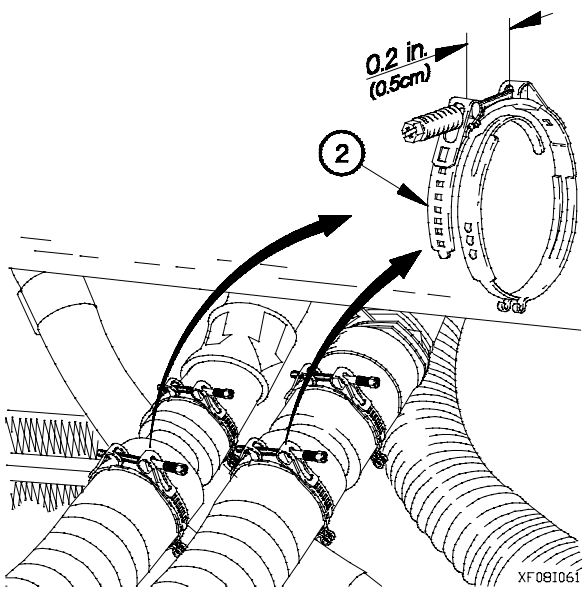

XF091061

NOTE

Minimum allowable gap on clamp is 0.2 in. (0.5 cm). If gap is less than 0.2 in. (0.5 cm), remove and re-install clamp.

(17) Measure gap on two clamps (2).

(18) Measure gap on clamp (2).

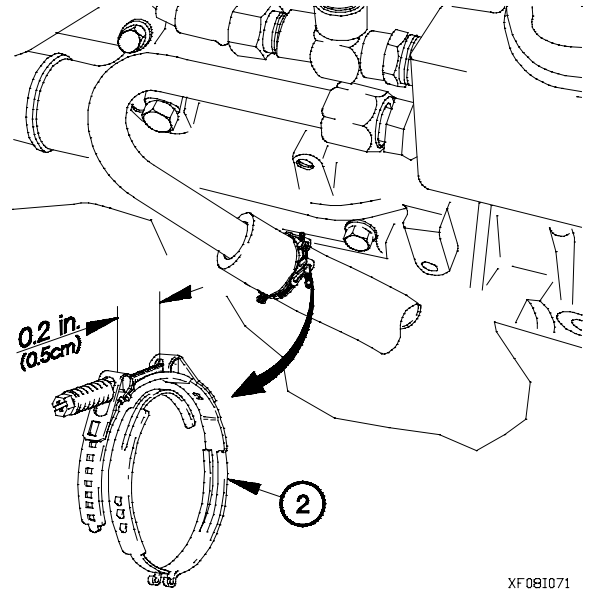

XF081071

(19) Measure gap on clamp (2).

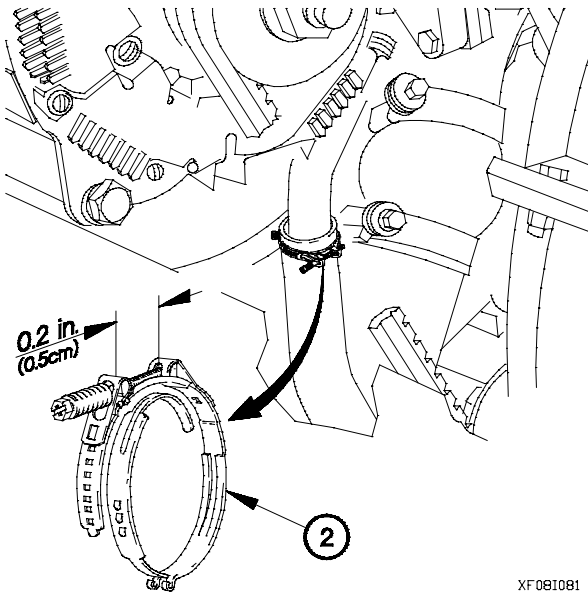

XF081081

(20) Lower cab (TM 9-2320-366-10-1).

(21) Position front grille (12) on cab (13) with washer (14) and screw (15).

(22) Position two washers (16) and screws (17) in front grille (12).

(23) Tighten screw (15) to 48-60 lb-in. (5-7 N-m).

(24) Tighten two screws (17) to 24 lb-in. (3 N-m).

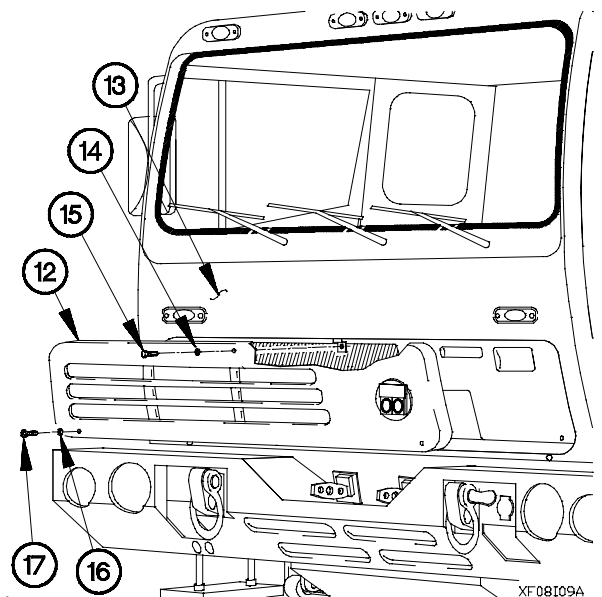

XF08109A

6-8. PERSONNEL HEATER HOSES REPLACEMENT (CONT)

c. Follow-On Maintenance.

- (1) Add coolant to radiator overflow tank (TM 9-2320-366-10-2).
- (2) Start engine (TM 9-2320-366-10-1).
- (3) Operate personnel heater (TM 9-2320-366-10-1).
- (4) Raise cab (TM 9-2320-366-10-1).
- (5) Check for coolant leaks around hoses and fittings.
- (6) Lower cab (TM 9-2320-366-10-1).
- (7) Shut down engine (TM 9-2320-366-10-1).

End of Task.

6-9. UPPER COOLANT TUBE AND HOSES REPLACEMENT

This task covers:

- a. Removal
- b. Installation
- c. Follow-On Maintenance

INITIAL SETUP

Equipment Conditions

- Engine shut down (TM 9-2320-366-10-1).
- Cab raised (TM 9-2320-366-10-1).
- Batteries disconnected (para 7-57).

Tools and Special Tools

- Pan, Drain (Item 24, Appendix C)
- Goggles, Industrial (Item 15, Appendix C)
- Tool Kit, Genl Mech (Item 46, Appendix C)
- Wrench, Torque, 0-75 lb-in. (Item 90, Appendix B)

Materials/Parts

- Antiseize Compound (Item 58, Appendix D)
- Antifreeze, Ethylene Glycol, Permanent (Item 12, Appendix D)

WARNING

Coolant may be very hot and under pressure from engine operation. Ensure engine is cool before performing maintenance. Failure to comply may result in injury to personnel.

a. Removal.

- (1) Remove radiator cap (1) from radiator overflow tank (2).

WARNING

Wear appropriate eye protection when working under vehicle due to the possibility of falling debris. Failure to comply may result in injury to personnel.

- (2) Position drain pan under radiator (3).
- (3) Open radiator draincock (4) and drain approximately one gallon of coolant.
- (4) Close radiator draincock (4).

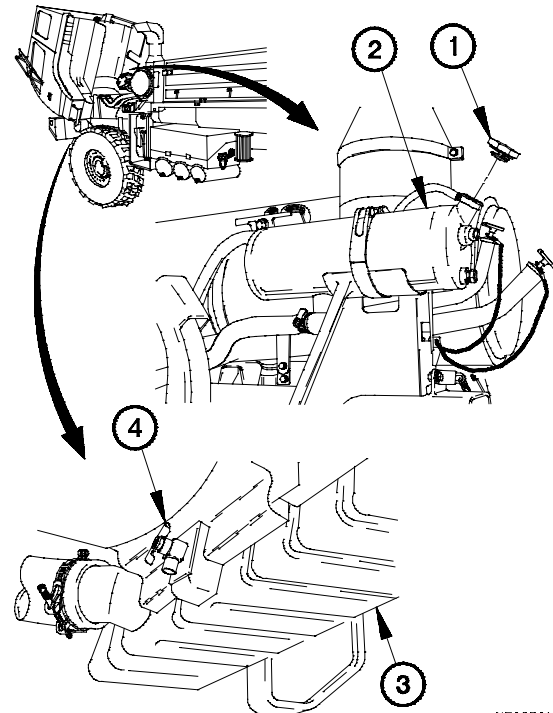

XF09R011

6-9. UPPER COOLANT TUBE AND HOSES REPLACEMENT (CONT)

- (5) Disconnect connector clamp (5) from water temperature switch electrical connector (6).
- (6) Disconnect water temperature switch electrical connector (6) from connector P36 (7).
- (7) Remove water temperature switch (8) from upper coolant tube (9).

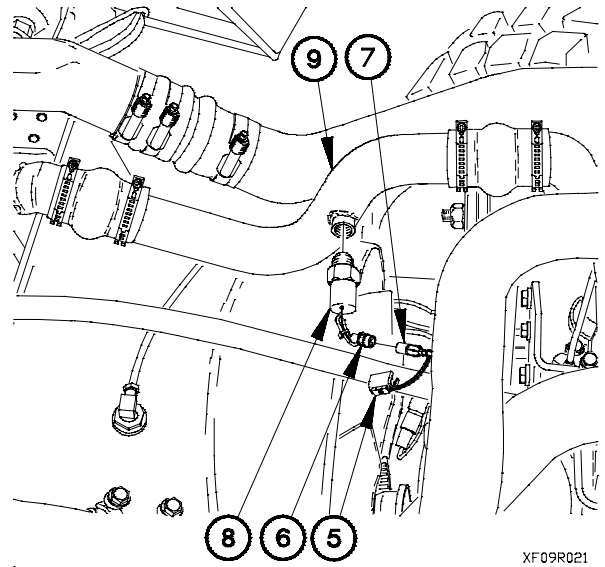

XF09R021

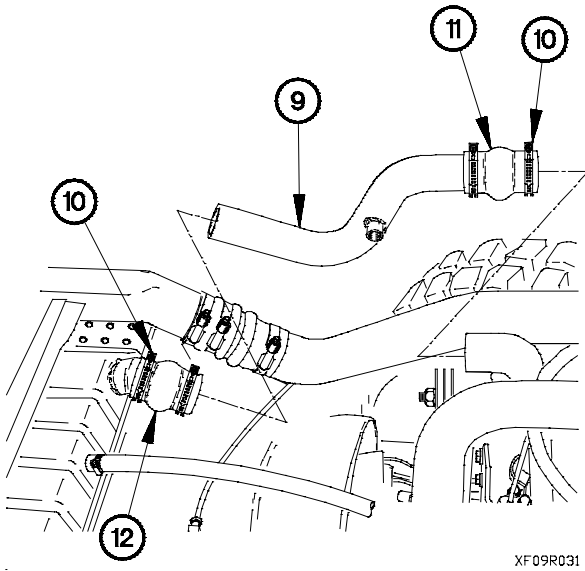

XF09R031

- (8) Loosen four hose clamps (10) on coolant hoses (11 and 12).
- (9) Slide coolant hose (11) completely onto upper coolant tube (9).
- (10) Remove upper coolant tube (9) from vehicle.

- (11) Remove coolant hose (12) from radiator (3).

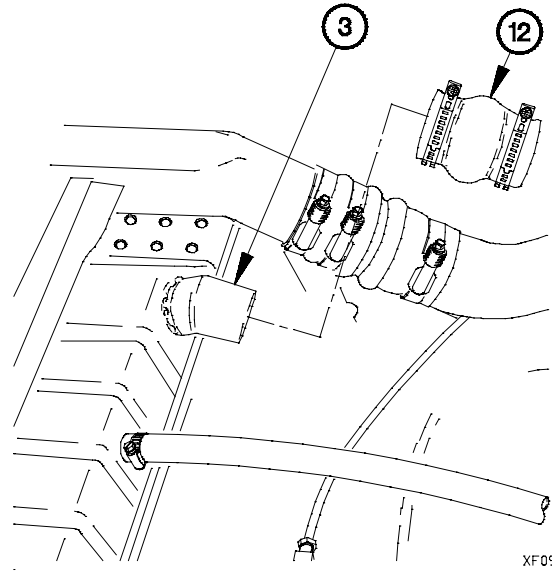

XF09R041

- (12) Remove coolant hose (11) from upper coolant tube (9).
- (13) Remove four clamps (10) from coolant hoses (11 and 12).

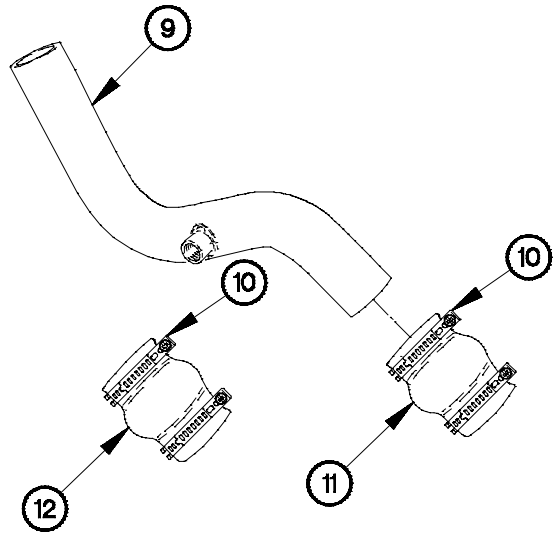

XF09R051

b. Installation.

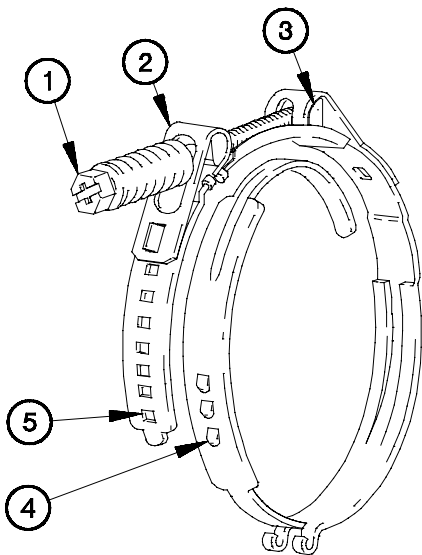

XF09I01A

NOTE

Both coolant hoses are assembled the same way. One coolant hose shown.

- (1) Loosen two screws (1) in clamps (2) as far as possible without disengaging screws from D-nuts (3).
- (2) Unhook clamp tabs (4) from tab windows (5).

6-9. UPPER COOLANT TUBE AND HOSES REPLACEMENT (CONT)

CAUTION

Clamp tongue must be started in clamp groove. Failure to comply may result in damage to equipment.

- (3) Position two clamps (2) on coolant hose (6).
- (4) Perform steps (1) through (3) on coolant hose (7).

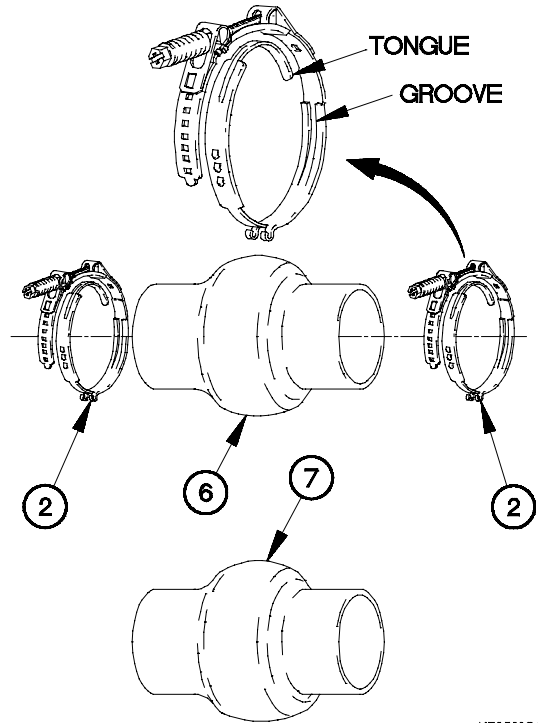

XF09I02A

- (5) Position coolant hose (6) on upper coolant tube (8).

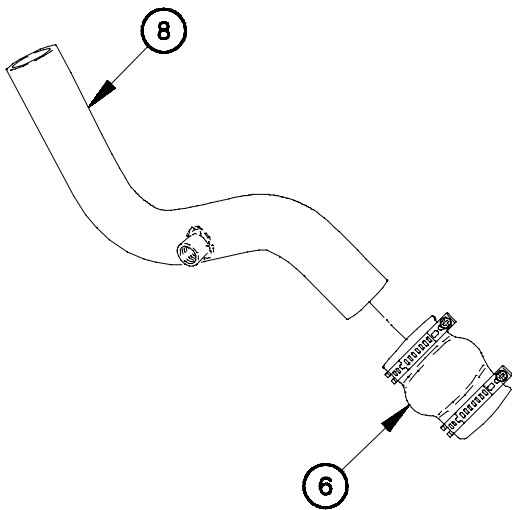

XF09I03A

- (6) Position coolant hose (7) on radiator (9).

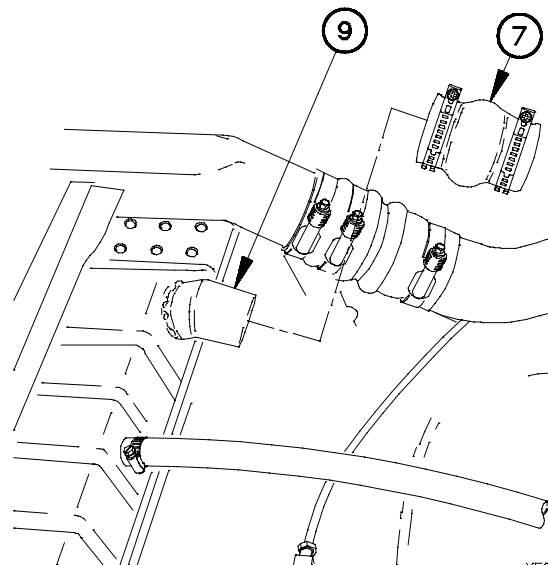

XF09I04A

- (7) Position upper coolant tube (8) between coolant hose (7) and thermostat housing (10).
- (8) Slide coolant hose (6) onto thermostat housing (10).
- (9) Engage as many clamp tabs (4) as possible in tab windows (5) allowing little or no play between four clamps and two coolant hoses (6 and 7).
- (10) Tighten four clamps (2) to 12-18 lb-in. (1-2 N-m).

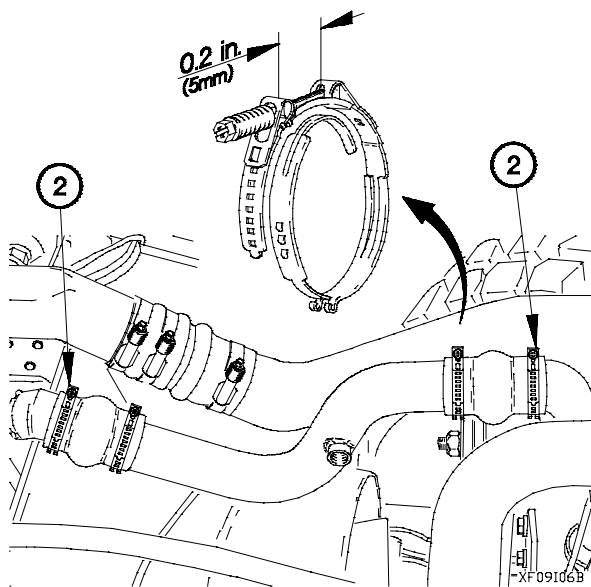
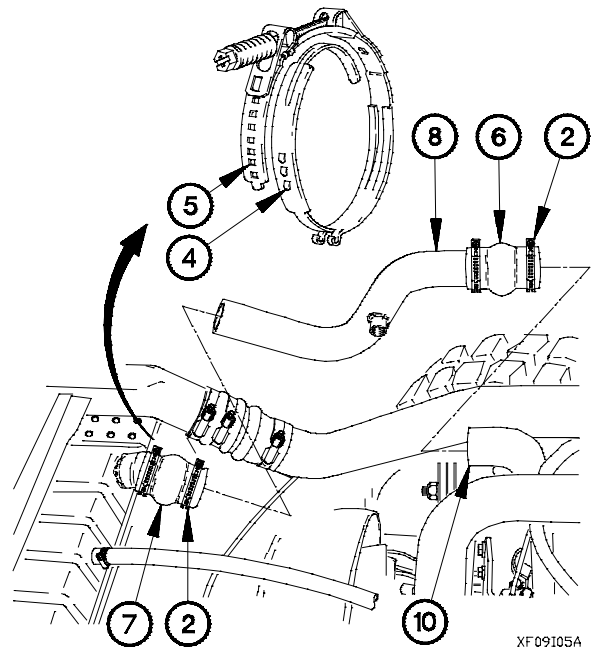

NOTE

Minimum allowable gap on clamp is 0.2 in. (5 mm). If gap is less than 0.2 in. (5 mm), remove and re-install clamp.

- (11) Measure gap on four clamps (2).

6-9. UPPER COOLANT TUBE AND HOSES REPLACEMENT (CONT)

WARNING

Adhesives, solvents, and sealing compounds can burn easily, can give off harmful vapors, and are harmful to skin and clothing. Keep away from open fire and use in a well-ventilated area. If adhesive, solvent, or sealing compound gets on skin or clothing, wash immediately with soap and water. Failure to comply may result in injury to personnel.

- (12) Apply antiseize compound to threads of water temperature switch (11).
- (13) Install water temperature switch (11) in upper coolant tube (8).
- (14) Connect water temperature switch electrical connector (12) to connector P36 (13).
- (15) Connect connector clamp (14) on water temperature switch electrical connector (12).

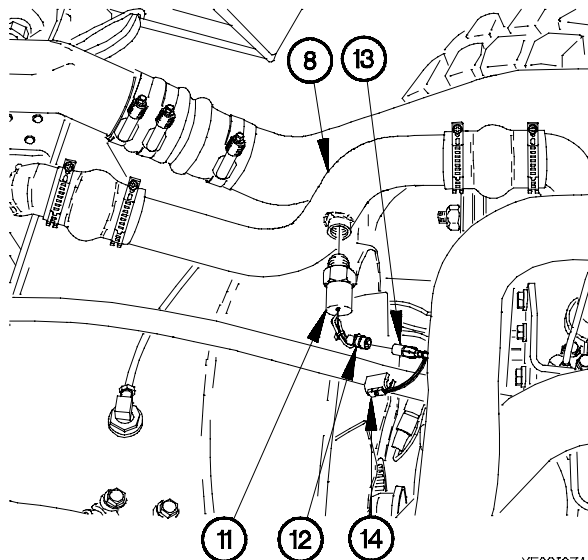

XF09I07A

c. Follow-On Maintenance.

- (1) Connect batteries (para 7-57).
- (2) Add coolant to radiator overflow tank (TM 9-2320-366-10-2).
- (3) Start engine (TM 9-2320-366-10-1).
- (4) Check for coolant leaks under vehicle.
- (5) Remove radiator cap from radiator overflow tank.
- (6) Check coolant level after normal operating temperature is reached. Add coolant as required (TM 9-2320-366-10-2).
- (7) Install radiator cap on radiator overflow tank.
- (8) Raise cab (TM 9-2320-366-10-1).
- (9) Check for coolant leaks around hoses and fittings.
- (10) Lower cab (TM 9-2320-366-10-1).
- (11) Shut down engine (TM 9-2320-366-10-1).

End of Task.

6-10. LOWER COOLANT HOSE REPLACEMENT

This task covers:

- a. Removal
- b. Installation
- c. Follow-On Maintenance

INITIAL SETUP

Equipment Conditions

Engine shut down (TM 9-2320-366-10-1).

Tools and Special Tools

Goggles, Industrial (Item 15, Appendix C)
 Container (52 qt (50 L) capacity)
 Tool Kit, Genl Mech (Item 46, Appendix C)
 Wrench, Torque, 0-75 lb-in. (Item 90, Appendix B)

Materials/Parts

Antifreeze, Ethylene Glycol, Permanent (Item 12, Appendix D)

WARNING

Coolant may be very hot and under pressure from engine operation. Ensure engine is cool before performing maintenance. Failure to comply may result in injury to personnel.

a. Removal.

- (1) Remove radiator cap (1) from radiator overflow tank (2).

WARNING

Wear appropriate eye protection when working under vehicle due to the possibility of falling debris. Failure to comply may result in injury to personnel.

- (2) Position container under radiator draincock (3).
- (3) Open radiator draincock (3) and drain coolant.
- (4) Close radiator draincock (3).

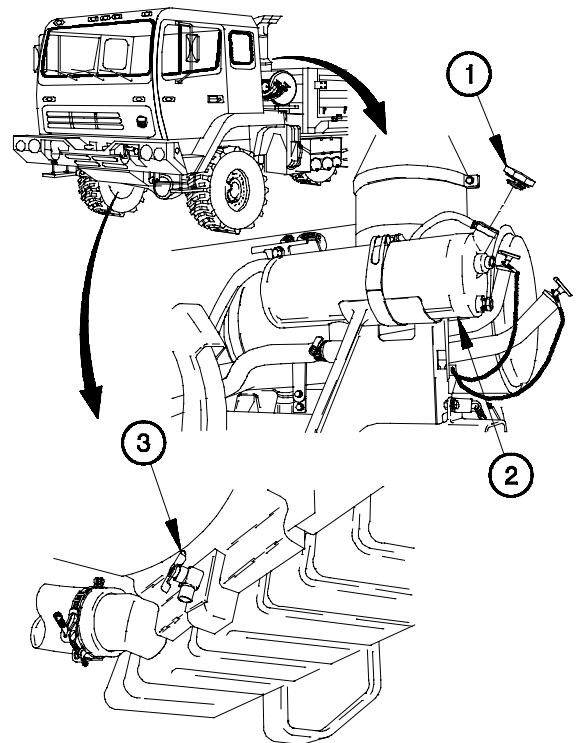

XF10R01A

6-10. LOWER COOLANT HOSE REPLACEMENT (CONT)

- (5) Loosen two clamps (4) on lower coolant hose (5).
- (6) Remove lower coolant hose (5) from radiator (6) and transmission oil cooler (7).

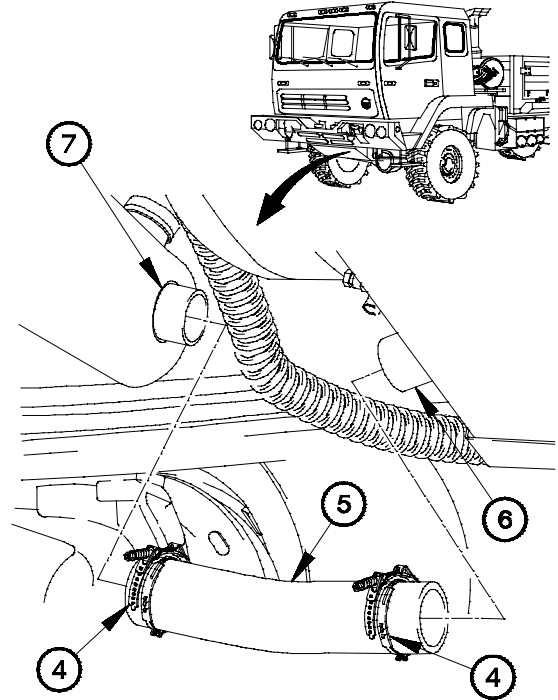

XF10R021

b. Installation.

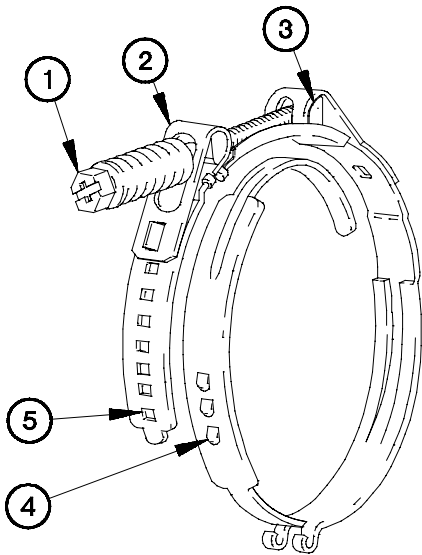

XF10I01A

- (1) Loosen two screws (1) in clamps (2) as far as possible without disengaging screws from D-nuts (3).
- (2) Unhook clamp tabs (4) from tab windows (5).

CAUTION

- Clamp tongue must be started in clamp groove. Failure to comply may result in damage to equipment.
- Position clamps so that screws will be toward center of vehicle and angled down.

(3) Position two clamps (2) on lower coolant hose (6).

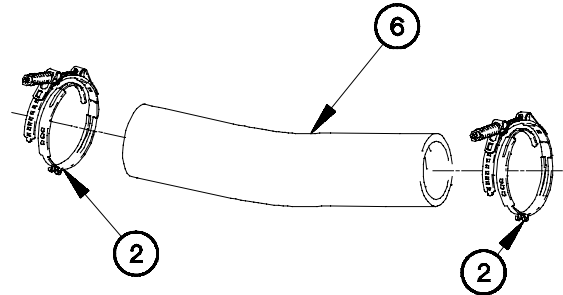

XF10I02A

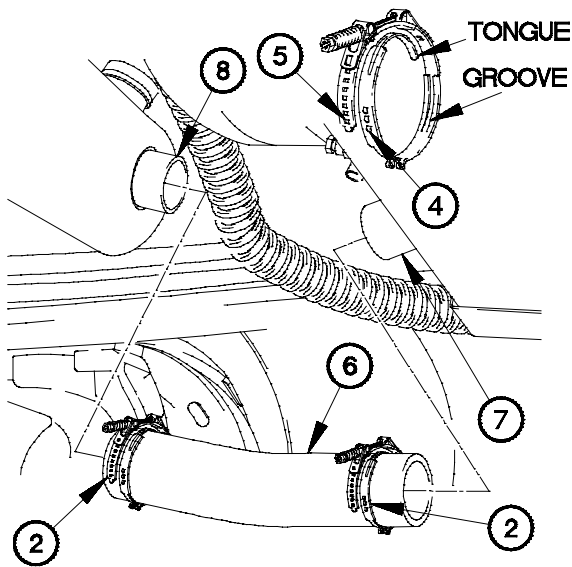

XF10I03I

- (4) Install lower coolant hose (6) between radiator (7) and transmission oil cooler (8).
- (5) Engage as many clamp tabs (4) as possible in tab windows (5) allowing little or no play between clamp and lower coolant hose (6).
- (6) Tighten two clamps (2) to 12-18 lb-in. (1-2 N·m).

NOTE

Minimum allowable gap on clamp is 0.2 in. (0.5 cm). If gap is less than 0.2 in. (0.5 cm), remove and re-install clamp.

(7) Measure gap on two clamps (2).

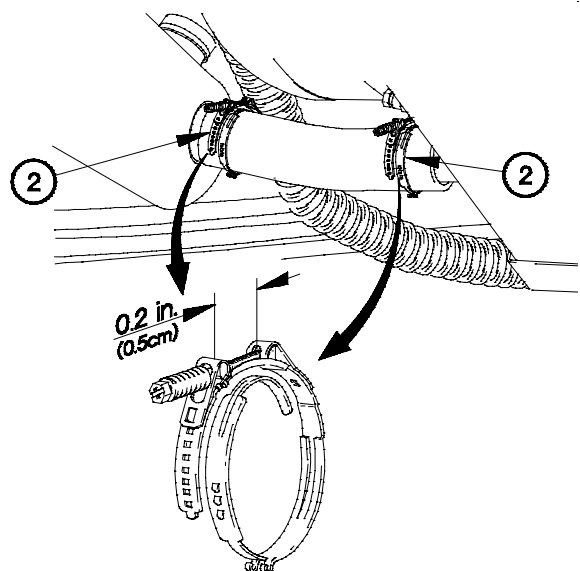

XF10I04I

6-10. LOWER COOLANT HOSE REPLACEMENT (CONT)

c. Follow-On Maintenance.

- (1) Add coolant to radiator overflow tank (TM 9-2320-366-10-2).
- (2) Install radiator cap on radiator overflow tank.
- (3) Start engine (TM 9-2320-366-10-1).
- (4) Check for coolant leaks around lower coolant hose.
- (5) Shut down engine (TM 9-2320-366-10-1).

End of Task.

6-11. AIR COMPRESSOR INLET AND OUTLET COOLANT TUBES REPLACEMENT

This task covers:

- a. Removal
- b. Installation
- c. Follow-On Maintenance

INITIAL SETUP

Equipment Conditions

Engine shut down (TM 9-2320-366-10-1).
Cab raised (TM 9-2320-366-10-1).

Materials/Parts

Antifreeze, Ethylene Glycol, Permanent (Item 12, Appendix D)

Tools and Special Tools

Pan, Drain (Item 24, Appendix C)
Tool Kit, Genl Mech (Item 46, Appendix C)

a. Removal.

- (1) Position drain pan under air compressor (1).
- (2) Disconnect air compressor inlet coolant tube (2) from air compressor (1).

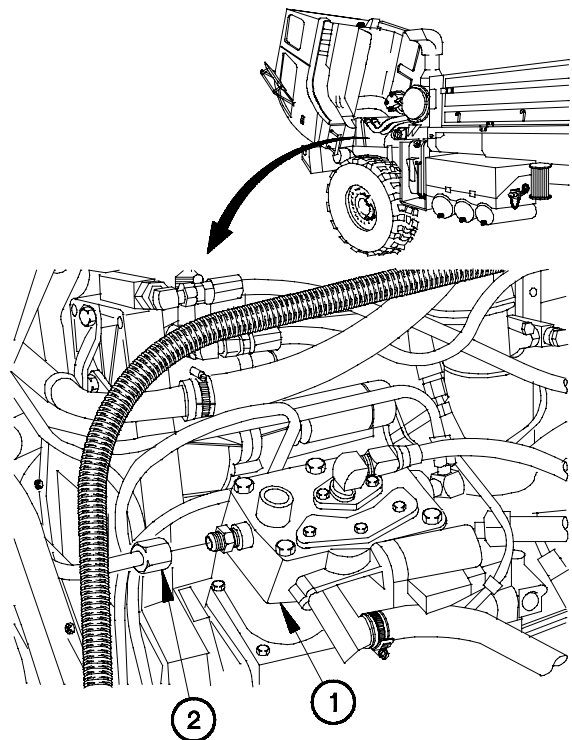
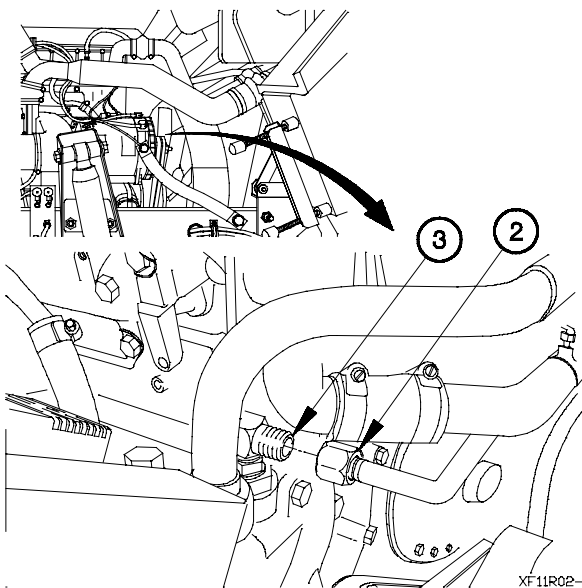

- (3) Disconnect air compressor inlet coolant tube (2) from water pump (3).
- (4) Remove air compressor inlet coolant tube (2) from vehicle.

6-11. AIR COMPRESSOR INLET AND OUTLET COOLANT TUBES REPLACEMENT (CONT)

- (5) Disconnect air compressor outlet coolant tube (4) from air compressor (1).

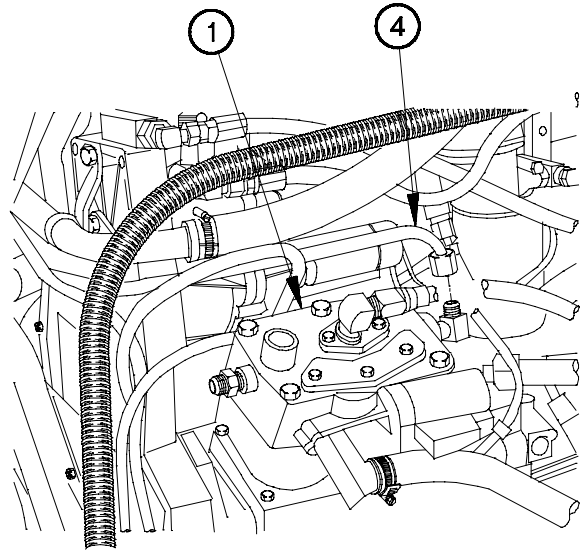

XF11R03-

- (6) Disconnect air compressor outlet coolant tube (4) from thermostat housing (5).
 (7) Remove air compressor outlet coolant tube (4) from vehicle.

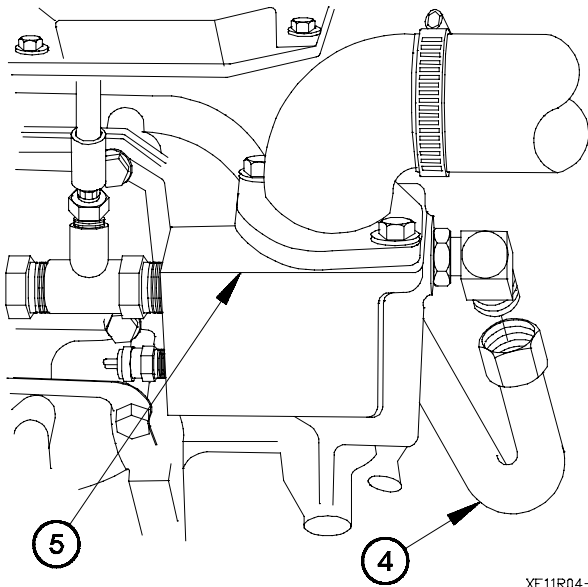

XF11R04-

b. Installation.

- (1) Connect air compressor outlet coolant tube (1) to thermostat housing (2).

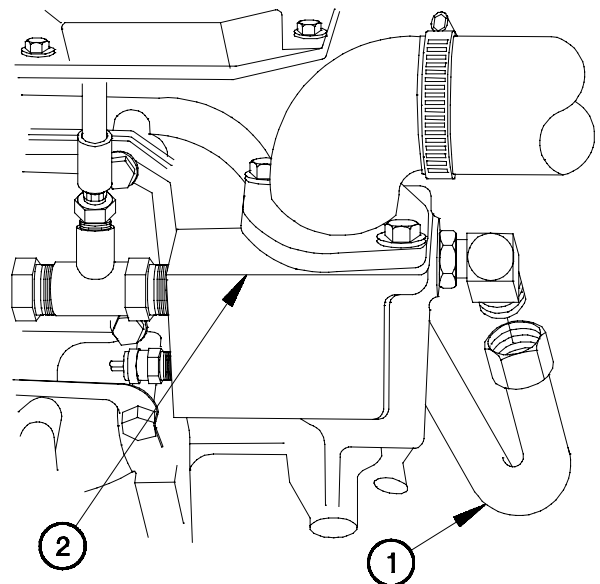

XF11I01-

(2) Connect air compressor outlet coolant tube (1) to air compressor (3).

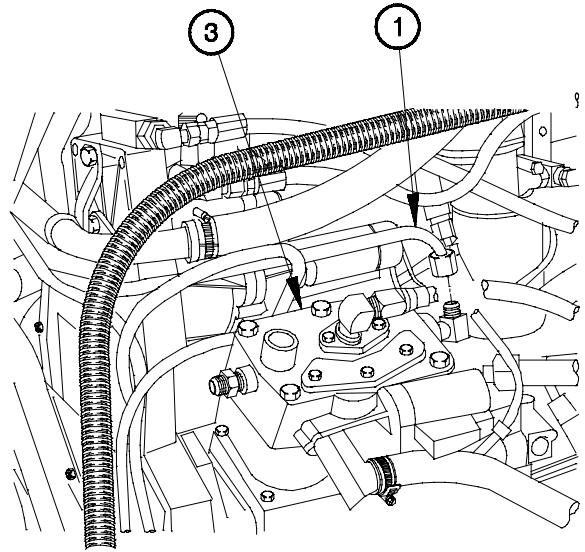

XF11I02-

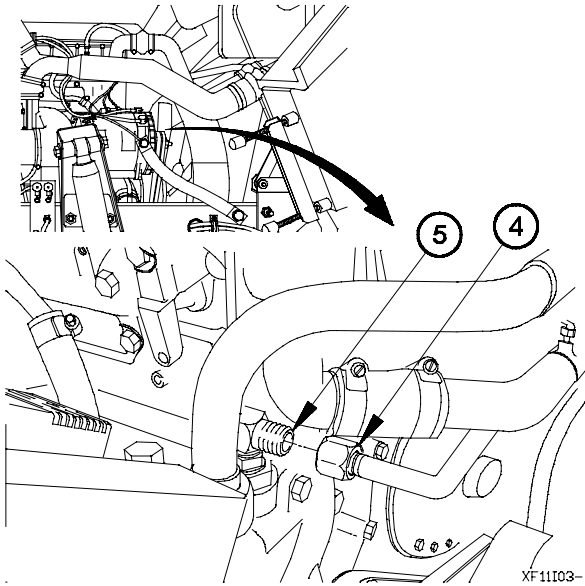

XF11I03-

(3) Connect air compressor inlet coolant tube (4) to air compressor (3).

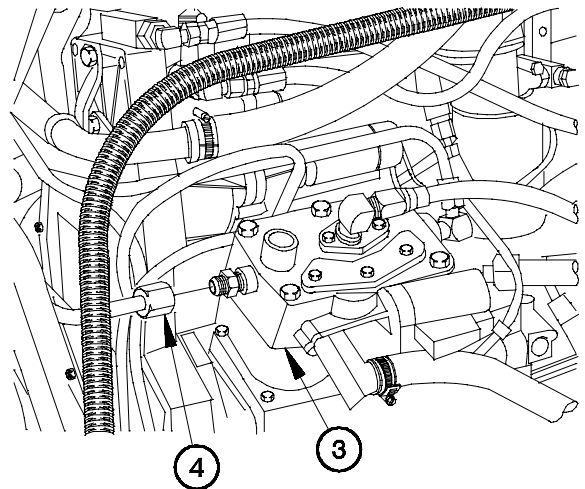

XF11I04-

(4) Connect air compressor inlet coolant tube (4) to air compressor (3).

6-11. AIR COMPRESSOR INLET AND OUTLET COOLANT TUBES REPLACEMENT (CONT)

c. Follow-On Maintenance.

- (1) Add coolant to radiator overflow tank (TM 9-2320-366-10-2).
- (2) Lower cab (TM 9-2320-366-10-1).
- (3) Start engine (TM 9-2320-366-10-1).
- (4) Check for coolant leaks under vehicle.
- (5) Check coolant level after normal operating temperature is reached. Add coolant as needed (TM 9-2320-366-10-2).
- (6) Install radiator cap on radiator overflow tank.
- (7) Raise cab (TM 9-2320-366-10-1).
- (8) Check for coolant leaks around coolant lines and fittings.
- (9) Lower cab (TM 9-2320-366-10-1).
- (10) Shut down engine (TM 9-2320-366-10-1).

End of Task.

6-12. WATER PUMP AND FITTINGS REPLACEMENT

This task covers:

- a. Water Pump Removal
- b. Water Pump Installation
- c. Fittings Removal
- d. Fittings Installation
- e. Follow-On Maintenance

INITIAL SETUP

Equipment Conditions

- 100 amp alternator removed, if equipped (para 7-2).
- 200 amp alternator removed, if equipped (para 20-45).
- Alternator brackets removed (para 7-4).

Tools and Special Tools

- Goggles, Industrial (Item 15, Appendix C)
- Container (52 qt (50 L) capacity)
- Tool Kit, Genl Mech (Item 46, Appendix C)
- Wrench, Torque, 0-75 lb-in. (Item 90, Appendix B)
- Wrench, Adjustable, Automotive (Item 53, Appendix C)
- Gage, Belt Tension (Item 18, Appendix B)
- Wrench, Torque, 0-175 lb-ft (Item 58, Appendix C)

Materials/Parts

- Antifreeze, Ethylene Glycol, Permanent (Item 12, Appendix D)
- Packing, Preformed (Item 195, Appendix G)
- Packing, Preformed (Item 214, Appendix G)
- Packing, Preformed (3) (Item 205, Appendix G)
- Packing, Preformed (2) (Item 202, Appendix G)

WARNING

Wear appropriate eye protection when working under vehicle due to the possibility of falling debris. Failure to comply may result in injury to personnel.

a. Water Pump Removal.

- (1) Position container under radiator (1).
- (2) Remove radiator cap (2) from radiator overflow tank (3).
- (3) Open radiator draincock (4) and drain coolant.
- (4) Close radiator draincock (4).

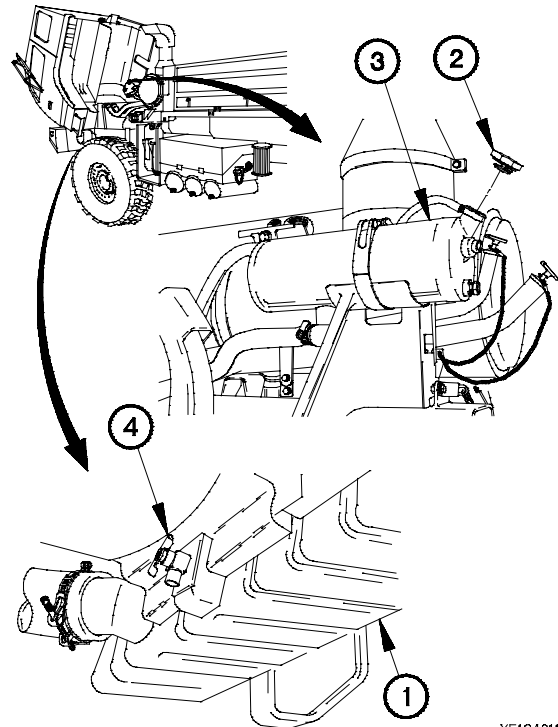

XF12A011

6-12. WATER PUMP AND FITTINGS REPLACEMENT (CONT)

- (5) Disconnect heater supply tube (5) from fitting (6).
- (6) Remove 45-degree fitting (6) and preformed packing (7) from water pump (8). Discard preformed packing.
- (7) Loosen two clamps (9).
- (8) Remove coolant hose (10) from water pump (8).

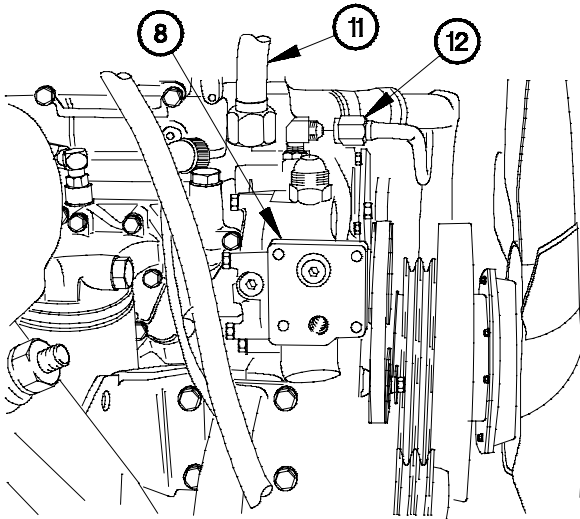
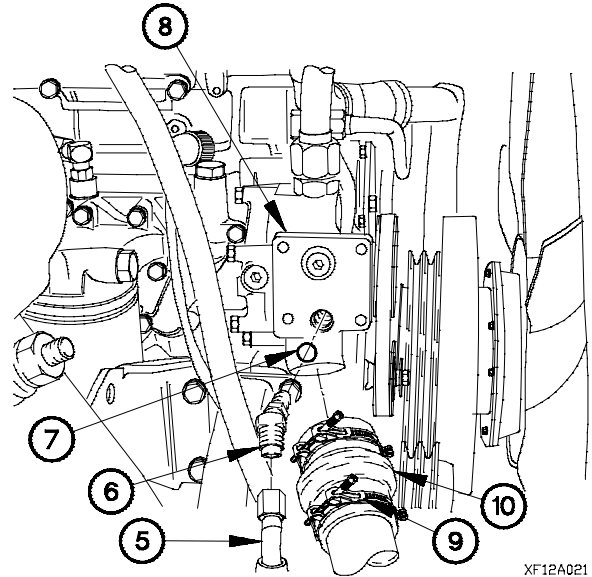

- (9) Disconnect coolant tubes (11 and 12) from water pump (8).

NOTE

Note position and size of washers prior to removal.

- (10) Remove two screws (13), washers (14), and drive belt/tension pulley (15) from engine (16).
- (11) Remove water pump drive belt (17) from water pump (8).

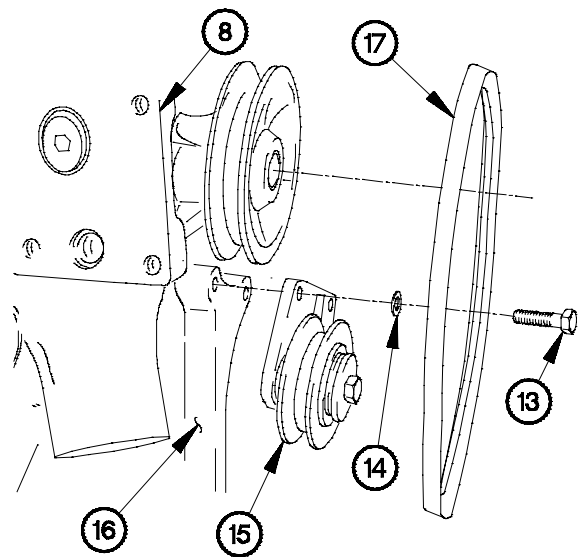

- (12) Remove four screws (18) from water pump (8).
- (13) Remove water pump (8) and preformed packings (19 and 20) from engine (16). Discard preformed packings.

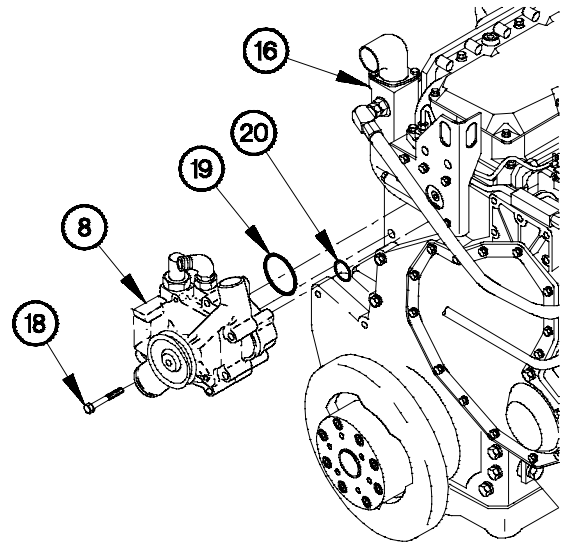

XF12A051

b. Water Pump Installation.

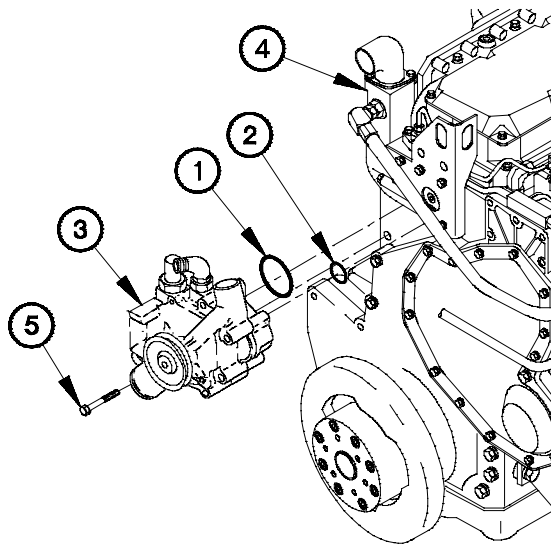

XF12B011

- (1) Install preformed packings (1 and 2) in water pump (3).
- (2) Position water pump (3) on engine (4) with four screws (5).
- (3) Tighten four screws (5) to 33-47 lb-ft (45-64 N·m).

6-12. WATER PUMP AND FITTINGS REPLACEMENT (CONT)

- (4) Position drive belt/tension pulley (6) on engine (4) with two washers (7) and screws (8).
- (5) Install water pump drive belt (9) on water pump (3) and drive belt/tension pulley (6).

NOTE

Use square hole in drive belt/tension pulley to apply and maintain tension on drive belt while adjusting belt tension.

- (6) Adjust water pump drive belt (9) with drive belt/tension pulley (6) as follows:
 - a. New belt (less than 30 minutes running time) 115-125 lb (512-556 N).
 - b. Used belt 80-100 lb (356-444 N).
- (7) Tighten two screws (8) to 35 lb-ft (47 N·m).

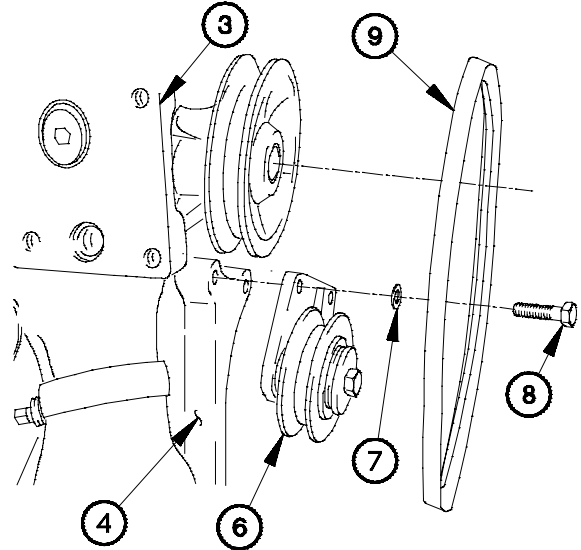

XF12B021

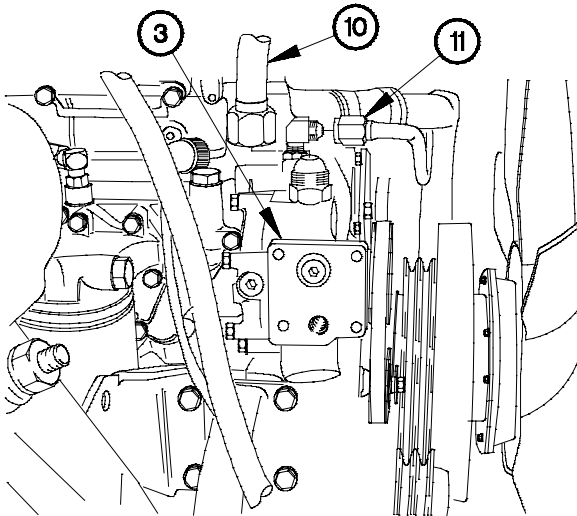

- (8) Connect coolant tubes (10 and 11) to water pump (3).

XF12B031

- (9) Loosen two screws (12) in clamps (13) as far as possible without disengaging screws from D-nuts (14).
- (10) Unhook clamp tabs (15) from tab windows (16).

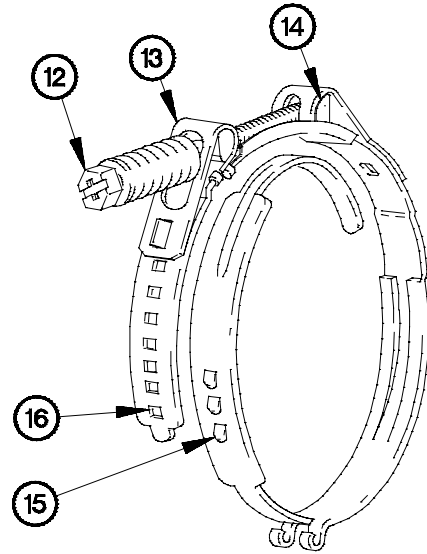

XF12B041

CAUTION

- Clamp tongue must be started in clamp groove. Failure to comply may result in damage to equipment.
- Position clamps with screw heads facing forward so they do not interfere with alternator mount.

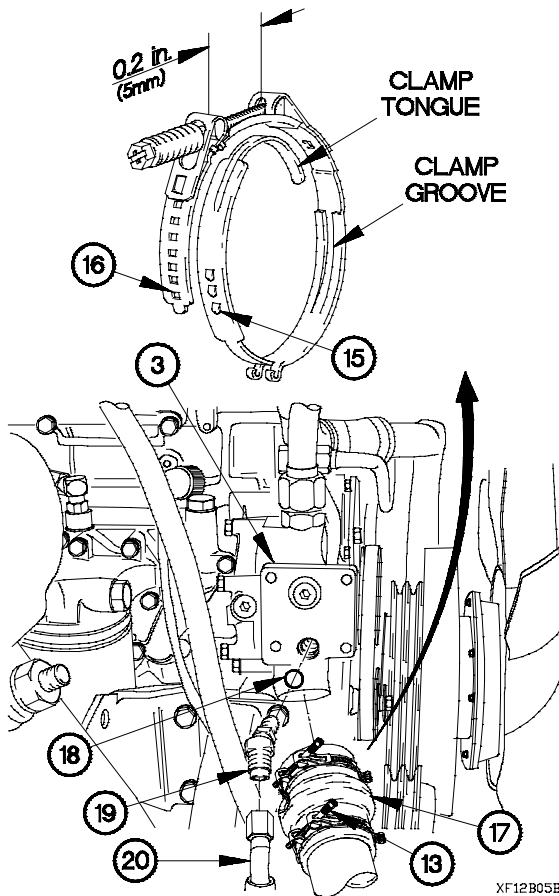

XF12B05B

- (11) Position coolant hose (17) on water pump (3).
- (12) Position two clamps (13) on coolant hose (17).
- (13) Engage as many clamp tabs (15) as possible in tab windows (16) allowing little or no play between clamp and coolant hose (17).
- (14) Tighten two clamps (13) to 13-17 lb-in. (2 N-m).

NOTE

Minimum allowable gap on clamp is 0.2 in. (5 mm). If gap is less than 0.2 in. (5 mm), remove and re-install clamp.

- (15) Measure gap on two clamps (13).
- (16) Install preformed packing (18) and 45-degree fitting (19) in water pump (3).
- (17) Connect heater supply tube (20) to 45-degree fitting (3).

6-12. WATER PUMP AND FITTINGS REPLACEMENT (CONT)

c. Fittings Removal.

- (1) Remove plug (1) and preformed packing (2) from water pump (3). Discard preformed packing.
- (2) Remove connector (4) and preformed packing (5) from water pump (3). Discard preformed packing.
- (3) Remove fitting (6) and preformed packing (7) from pipe bushing (8). Discard preformed packing.
- (4) Remove pipe bushing (8) and preformed packing (9) from water pump (3). Discard preformed packing.

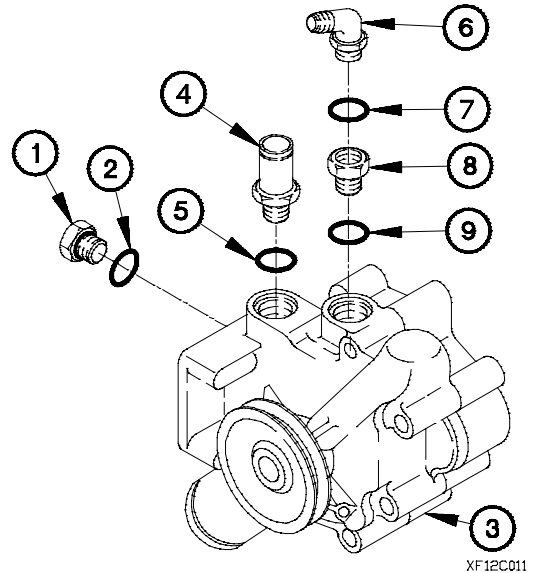

d. Fittings Installation.

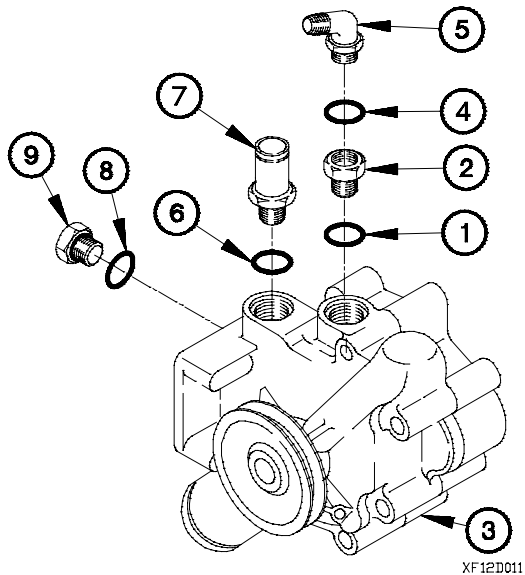

- (1) Install preformed packing (1) on pipe bushing (2).
- (2) Install pipe bushing (2) in water pump (3).
- (3) Install preformed packing (4) on fitting (5).
- (4) Install fitting (5) in pipe bushing (2).
- (5) Install preformed packing (6) on connector (7).
- (6) Install connector (7) in water pump (3).
- (7) Install preformed packing (8) on plug (9).
- (8) Install plug (9) in water pump (3).

e. Follow-On Maintenance.

- (1) Install alternator bracket assembly (para 7-4).
- (2) Install alternator (para 7-2 or 20-45).
- (3) Add coolant to radiator overflow tank (TM 9-2320-366-10-2).
- (4) Lower cab (TM 9-2320-366-10-1).
- (5) Start engine (TM 9-2320-366-10-1).
- (6) Check for coolant leaks under vehicle.
- (7) Check coolant level after normal operating temperature is reached. Add coolant as required (TM 9-2320-366-10-2).
- (8) Raise cab (TM 9-2320-366-10-1).
- (9) Check for coolant leaks around water pump.
- (10) Lower cab (TM 9-2320-366-10-1).
- (11) Shut down engine (TM 9-2320-366-10-1).

End of Task.

6-13. DRIVE BELT AND TENSION PULLEY REPLACEMENT

This task covers:

- a. Removal
- b. Installation
- c. Follow-On Maintenance

INITIAL SETUP

Equipment Conditions

Top radiator fan shroud removed (para 6-4).

Tools and Special Tools

Tool Kit, Genl Mech (Item 46, Appendix C)
 Gage, Belt Tension (Item 18, Appendix B)
 Wrench, Torque, 0-175 lb-ft (Item 58, Appendix C)

Materials/Parts

Antiseize Compound (Item 58, Appendix D)
 Lockwasher (6) (Item 95, Appendix G)
 Screw, Self-Locking (6) (Item 263, Appendix G)
 Grommet, Nonmetallic (Item 53, Appendix G)

a. Removal.

CAUTION

Mark front of engine fan before removing. Failure to comply may result in damage to equipment.

- (1) Remove air hose (1) from fitting (2) on fan clutch assembly (3).
- (2) Remove fitting (2) from fan clutch assembly (3).

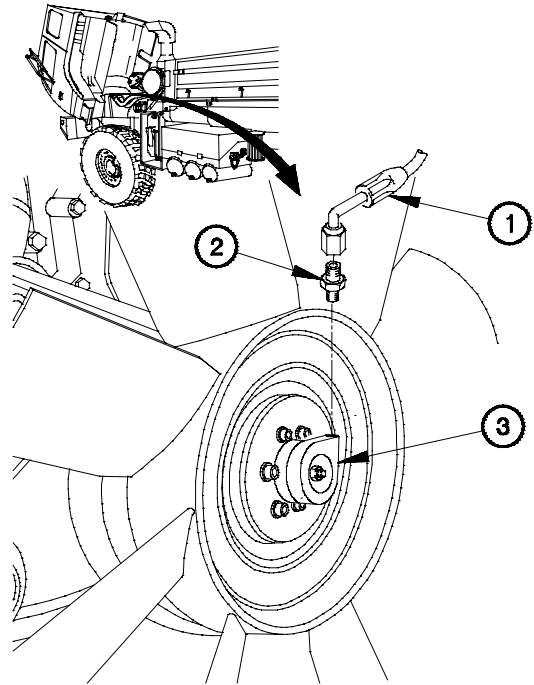

XF13R01A

NOTE

Perform steps (3) through (6) on vehicles serial number 8426 and lower that have not had the fan clutch replaced.

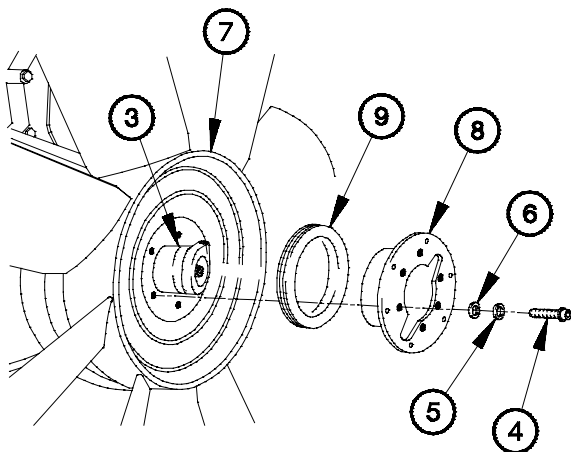

XF13R02A

- (3) Remove six screws (4), lockwashers (5), and washers (6) from engine fan (7). Discard lockwashers and screws.
- (4) Remove engine fan (7) from fan clutch assembly (3).
- (5) Remove fan support plate (8) from engine fan (7).
- (6) Remove grommet (9) from engine fan (7). Discard grommet.

NOTE

Perform steps (6.1) and (6.2) on vehicles serial number 8427 and higher and vehicles that have previously had the fan clutch replaced.

- (6.1) Remove six nuts (9.1), lockwashers (9.2), and washers (9.3) from engine fan (9.4). Discard lockwashers.
- (6.2) Remove engine fan (9.4) from fan clutch assembly (9.5).

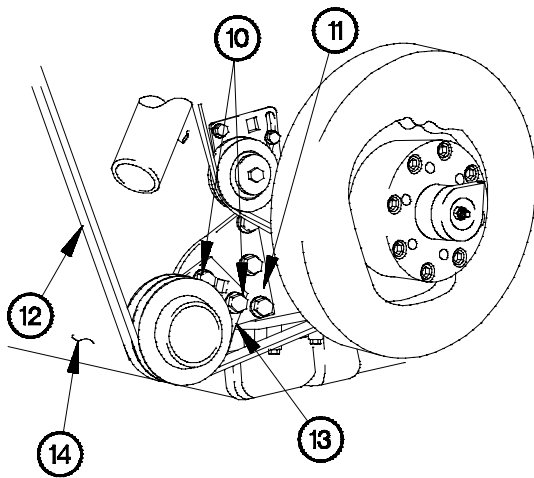
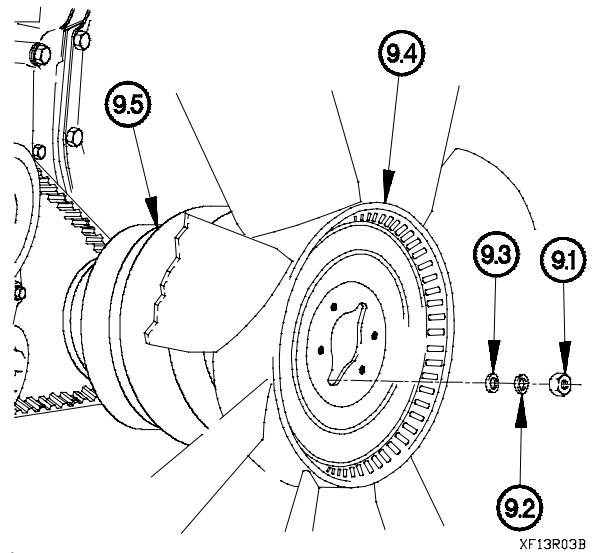

- (7) Loosen two screws (10) from front of engine block (11).
- (8) Release alternator belts (12) tension by moving tension bracket (13) up.
- (9) Remove two alternator belts (12) from engine (14).

- (10) Remove two screws (15), washers (16), and tension pulley (17) from engine (14).
- (11) Remove drive belt (18) from water pump pulley (19) and pulley damper (20).

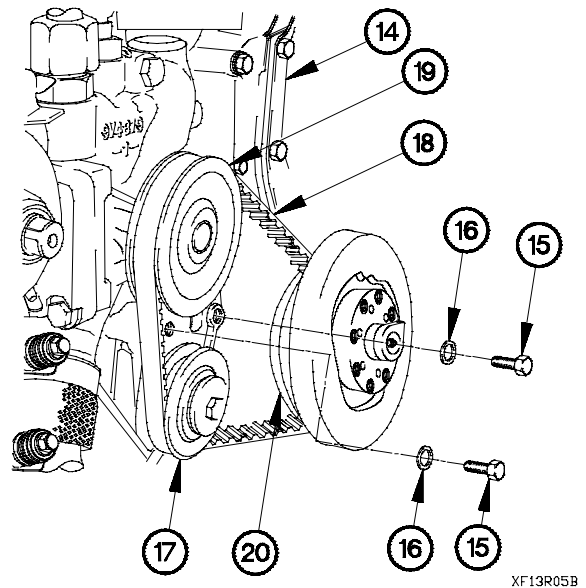

6-13. DRIVE BELT AND TENSION PULLEY REPLACEMENT (CONT)

b. Installation.

- (1) Install drive belt (1) on pulley damper (2) and water pump pulley (3).
- (2) Position tension pulley (4) on engine (5) with two washers (6) and screws (7).

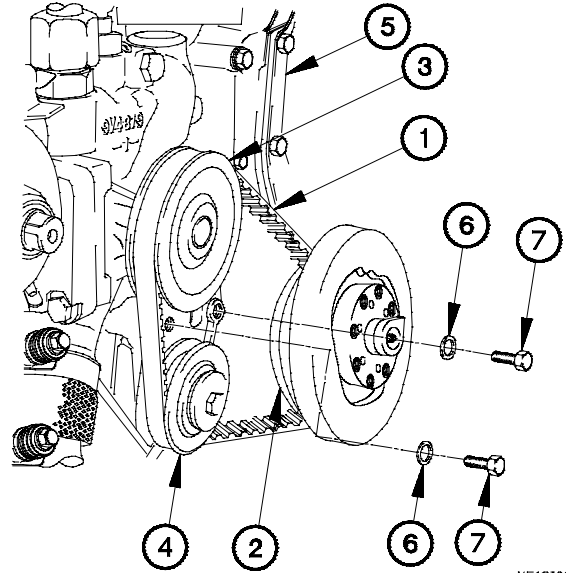

XF13101B

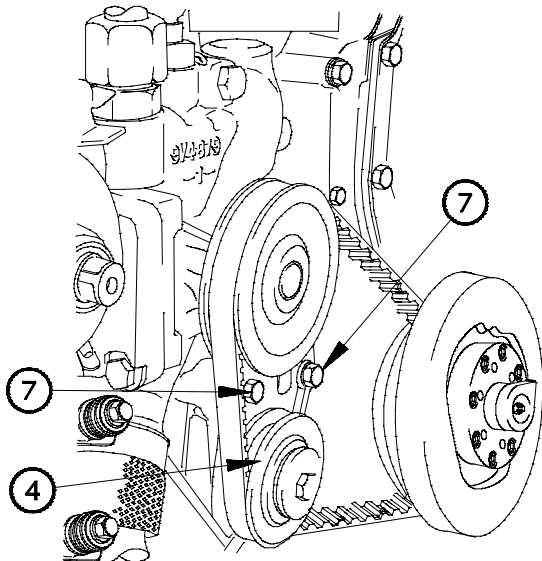

XF13102B

NOTE

Use square hole in drive belt/tension pulley to apply and maintain tension on drive belt while adjusting belt tension.

- (3) Adjust water pump drive belt with drive belt/tension pulley (4) as follows:
 - (a) New belt (less than 30 minutes running time) 115-125 lb (512-556 N).
 - (b) Used belt 80-100 lb (356-444 N).
- (4) Tighten two screws (7) to 35 lb-ft (47 N•m).

- (5) Install two alternator belts (8) onto engine (5).

NOTE

Use square hole in drive belt/tension bracket to apply and maintain tension on alternator belts while adjusting belt tension.

- (6) Adjust alternator belts with tension bracket (9) as follows:

- (a) New belt (less than 30 minutes running time) 115-125 lb (512-556 N).
- (b) Used belt 80-100 lb (356-444 N).

- (7) Tighten screw (10).

- (8) Tighten screw (11) to 47 lb-ft (64 N•m).

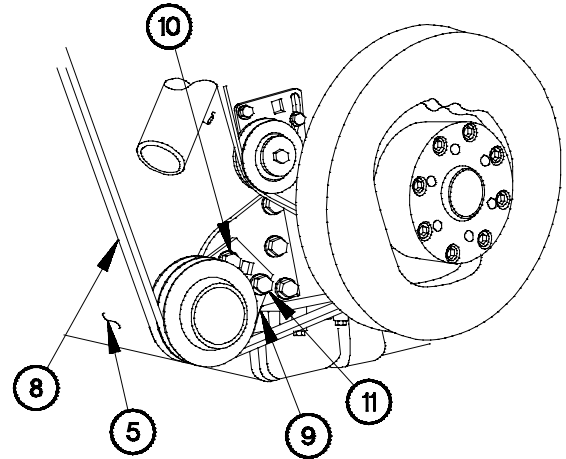

XF13103-

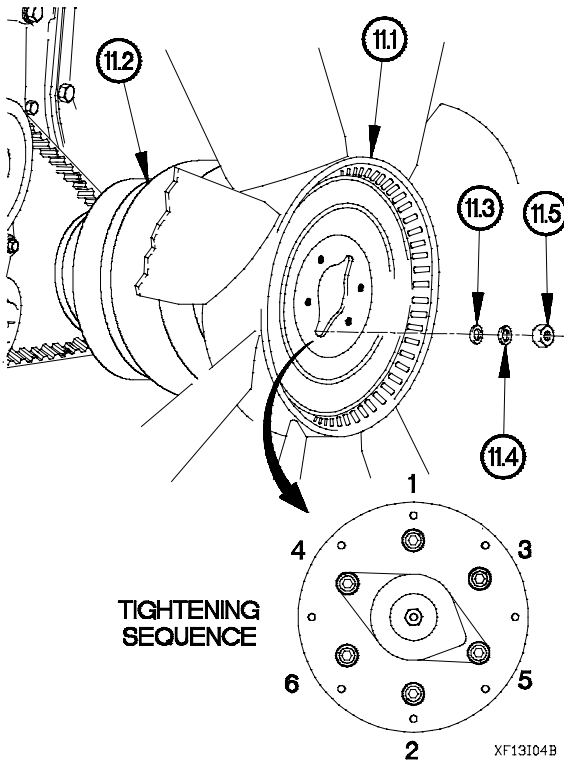

CAUTION

Ensure engine fan is positioned with mark facing forward. Failure to comply may result in damage to equipment.

NOTE

Perform steps (8.1) through (8.3) on vehicles serial number 8427 and higher.

- (8.1) Position engine fan (11.1) on fan clutch assembly (11.2) with six washers, lockwashers
- (8.2) Tighten six nuts (11.5) to 15 lb-ft (20 N•m) in sequence shown.
- (8.3) Re-tighten six nuts (11.5) to 23-29 lb-ft (31-39 N•m) in sequence shown.

NOTE

Perform steps (9) through (13) on vehicles serial numbers 8426 and lower that have not had fan clutch replaced.

- (9) Install grommet (12) on engine fan (13).
- (10) Install fan support plate (14) on engine fan (13).
- (11) Position engine fan (13) and fan support plate (14) on fan clutch assembly (15) with six washers (16), lockwashers (17), and screws (18).
- (12) Tighten six screws (18) to 15 lb-ft (20 N·m) in sequence shown.
- (13) Re-tighten six screws (18) to 22-32 lb-ft (30-44 N·m) in sequence shown.

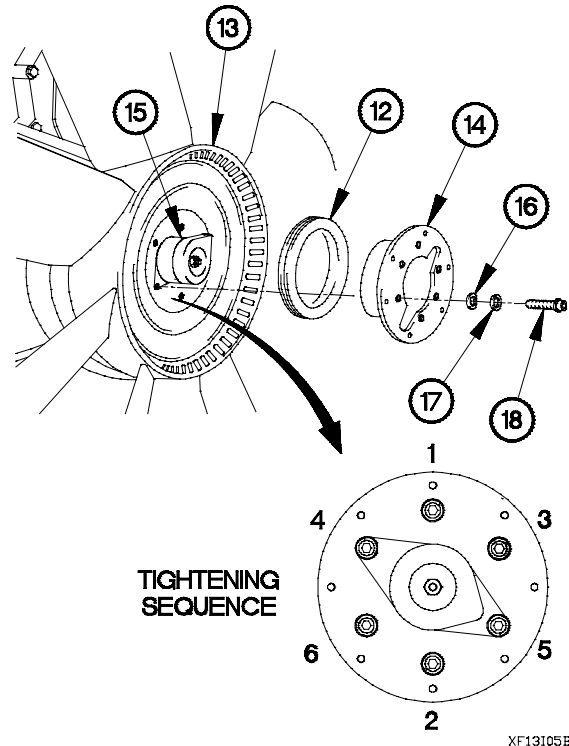

WARNING

Adhesives, solvents, and sealing compounds can burn easily, can give off harmful vapors, and are harmful to skin and clothing. Keep away from open fire and use in a well-ventilated area. If adhesive, solvent, or sealing compound gets on skin or clothing, wash immediately with soap and water. Failure to comply may result in injury to personnel.

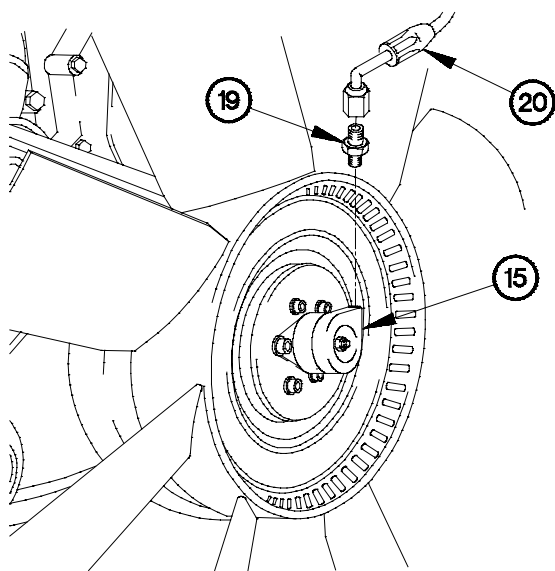

- (14) Apply antiseize compound to threads of fitting (19).
- (15) Install fitting (19) on fan clutch assembly (15).
- (16) Connect air hose (20) to fitting (19).

c. Follow-On Maintenance.

Install top radiator fan shroud (para 6-4).

End of Task.

6-14. ENGINE FAN AND FAN CLUTCH ASSEMBLY REPLACEMENT	
This task covers:	
a. Removal b. Installation	c. Follow-On Maintenance
INITIAL SETUP	
Equipment Conditions Top radiator fan shroud removed (para 6-4).	Materials/Parts Antiseize Compound (Item 13, Appendix D) Lockwasher (6) (Item 95, Appendix G) Screw, Self-Locking (6) (Item 263, Appendix G)
Tools and Special Tools Tool Kit, Genl Mech (Item 46, Appendix C) Wrench, Torque, 0-175 lb-ft (Item 58, Appendix C) Adapter, Socket Wrench (Item 2, Appendix B)	

a. Removal.

- (1) Disconnect air hose (1) from fitting (2) on fan clutch assembly (3).
- (2) Remove fitting (2) from fan clutch assembly (3).

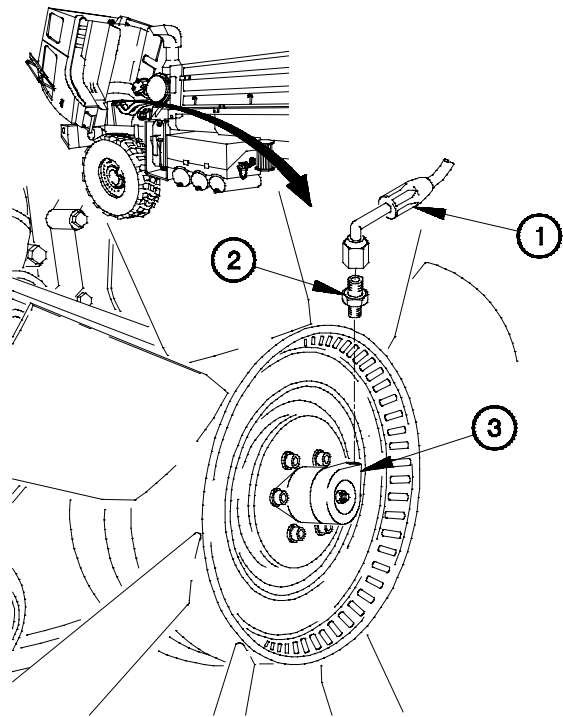

XF14R01B

NOTE

Perform steps (3) through (8) on vehicles serial number 8426 and lower that have not had the fan clutch replaced.

- (3) Remove six screws (4), lockwashers (5), and washers (6) from engine fan (7). Discard lockwashers and screws.
- (4) Remove fan support plate (8) from engine fan (7).
- (5) Remove grommet (9) from engine fan (7). Discard grommet.

CAUTION

Mark front of engine fan before removal. Failure to comply may result in damage to equipment.

- (6) Remove engine fan (7) from fan clutch assembly (3).

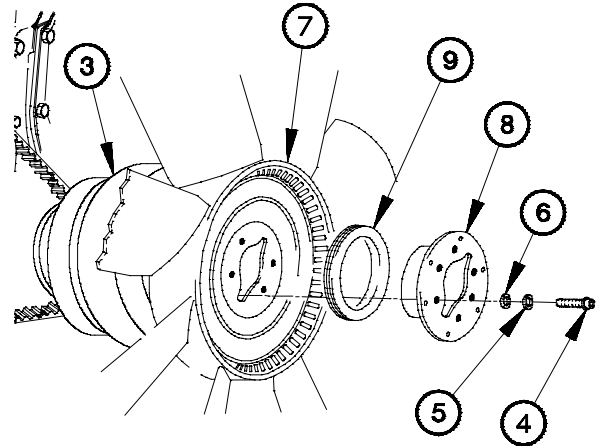

XF14R02B

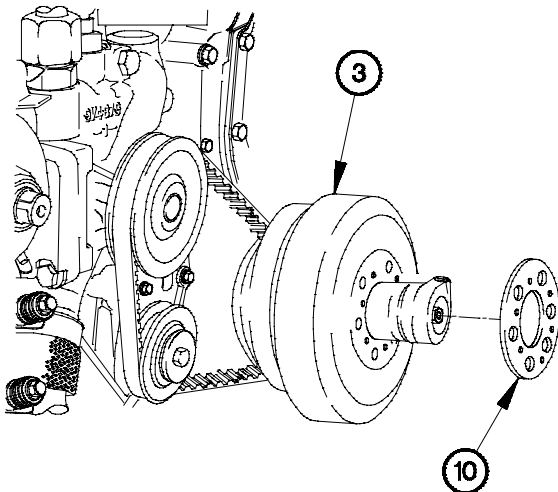

XF14R03B

- (7) Remove spacer plate (10) from fan clutch assembly (3).

6-14. ENGINE FAN AND FAN CLUTCH ASSEMBLY REPLACEMENT (CONT)

NOTE

Perform steps (8) and (8.1) on vehicles serial number 8427 and higher and on vehicles that have had the fan clutch replaced.

- (8) Remove six nuts (10.1), lockwashers (10.2), and washers (10.3) from engine fan (10.4). Discard lockwashers.

CAUTION

Mark front of engine fan before removal. Failure to comply may result in damage to equipment.

- (8.1) Remove engine fan (10.4) from fan clutch assembly (10.5).

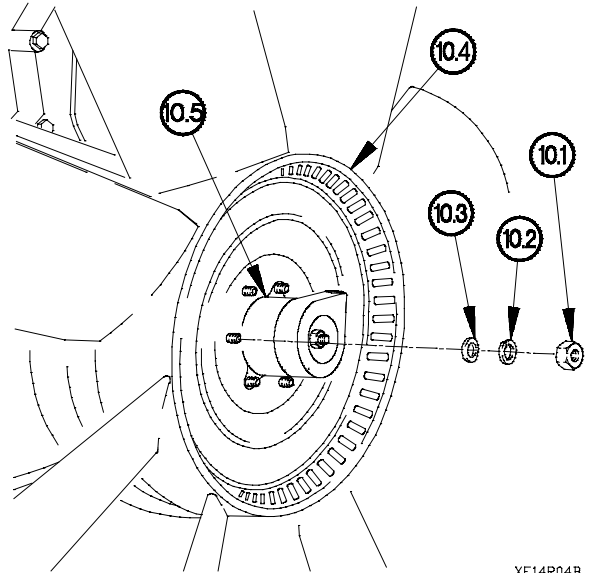

XF14R04B

NOTE

- Application of 30 psi (207 kPa) air pressure to fan clutch will free rotation of fan clutch and allow removal of fan clutch screws.
- Both fan clutches are removed the same way. Fan clutch without studs shown.

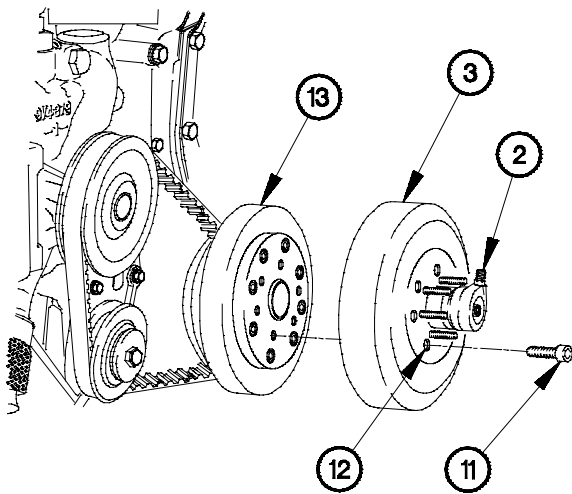

XF14R05B

- (8.2) Install fitting (2) in fan clutch assembly (3).
- (9) Apply 30 psi (207 kPa) air pressure to fitting (2).
- (10) Turn fan clutch assembly (3) until bolts (11) are visible through fan clutch access holes (12).
- (11) Remove six bolts (11) from pulley damper (13).
- (12) Remove fan clutch assembly (3) from pulley damper (13).

b. Installation.

NOTE

Discard fan clutch assembly PN 1090-08000-03 and replace with fan clutch assembly PN 1090-08000-01.

- (1) Position bolt (1) through hole (1.1) in fan clutch assembly (2).
- (2) Position fan clutch assembly (2) on pulley damper (3).
- (3) Position five bolts (1) on fan clutch assembly (2).
- (4) Tighten six bolts (1) to 42-52 lb-ft (57-71 N•m).

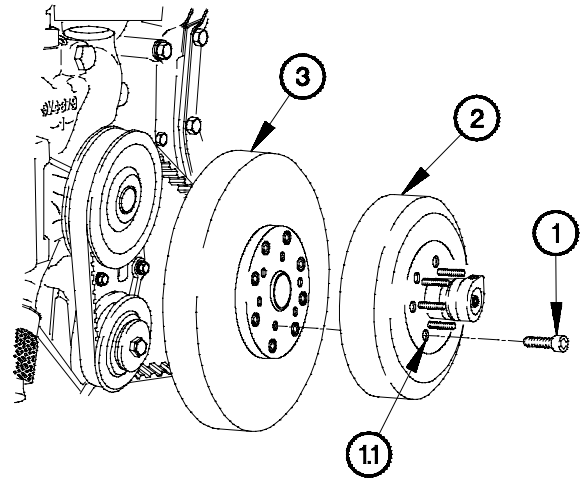

XF14101B

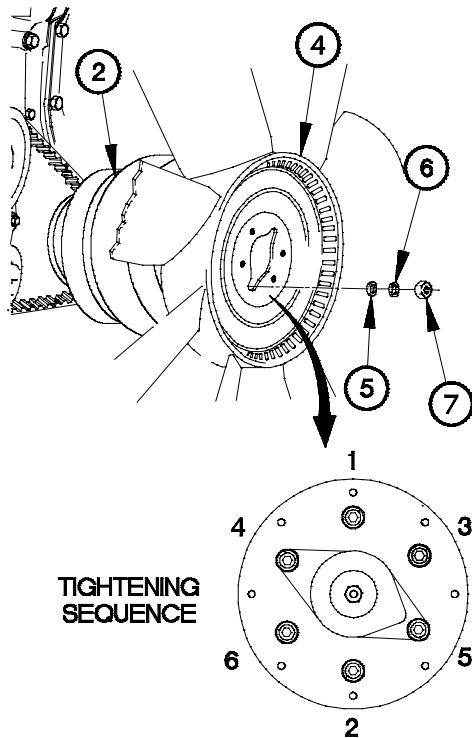

**TIGHTENING
SEQUENCE**

XF14102B

CAUTION

Ensure engine fan is positioned with mark facing forward. Failure to comply may result in damage to equipment.

NOTE

Discard engine fan PN 4035-41393-74 and replace with engine fan PN 12421972.

- (5) Position engine fan (4) on fan clutch assembly (2) with six washers (5), lockwashers (6), and nuts (7).
- (6) Tighten six nuts (7) to 15 lb-ft (20 N•m) in sequence shown.
- (7) Re-tighten six nuts (7) to 23-29 lb-ft (31-39 N•m) in sequence shown.

6-14. ENGINE FAN AND FAN CLUTCH ASSEMBLY REPLACEMENT (CONT)

WARNING

Adhesives, solvents, and sealing compounds can burn easily, can give off harmful vapors, and are harmful to skin and clothing. Keep away from open fire and use in a well-ventilated area. If adhesive, solvent, or sealing compound gets on skin or clothing, wash immediately with soap and water. Failure to comply may result in injury to personnel.

- (8) Apply antiseize compound to threads of fitting (8).
- (9) Install fitting (8) in fan clutch assembly (2).
- (10) Connect air hose (9) to fitting (8).

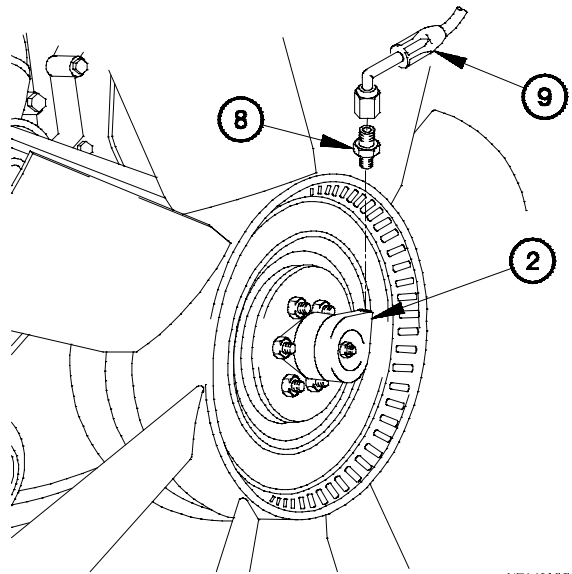

XF14103B

c. Follow-On Maintenance.

- (1) Install top radiator fan shroud (para 6-4).
- (2) Lower cab (TM 9-2320-366-10-1).
- (3) Start engine (TM 9-2320-366-10-1).
- (4) Check for coolant leaks under vehicle.
- (5) Raise cab (TM 9-2320-366-10-1).
- (6) Check for coolant leaks around radiator.
- (7) Lower cab (TM 9-2320-366-10-1).
- (8) Shut down engine (TM 9-2320-366-10-1).

End of Task.

CHAPTER 7 ELECTRICAL SYSTEM MAINTENANCE

RESTRICTED MAINTENANCE NOTICE

Units not authorized SC 4910-95-CL-A72 (SHOP EQUIPMENT, COMMON NO. 2) in their T.O.E. may be unable to perform some of the maintenance tasks described in this chapter. If the required tools are not authorized, the equipment must be submitted to DS Maintenance for repair.

Section I. INTRODUCTION	7-4
7-1. INTRODUCTION	7-4
Section II. MAINTENANCE PROCEDURES	7-5
7-2. 100 AMP ALTERNATOR REPLACEMENT	7-5
7-3. ALTERNATOR BELTS REPLACEMENT	7-11
7-4. ALTERNATOR BRACKETS REPLACEMENT	7-14
7-5. 100 AMP VOLTAGE REGULATOR REPLACEMENT	7-20
7-6. AUXILIARY STARTER SOLENOID REPLACEMENT	7-23
7-7. STARTING MOTOR REPLACEMENT	7-27
7-8. AUXILIARY PANEL REPLACEMENT	7-34
7-9. CIRCUIT BREAKER, DIODE, AND RELAY REPLACEMENT	7-38
7-10. WTEC II DASHBOARD CABLE ASSEMBLY REPLACEMENT/REPAIR	7-39
7-11. WTEC III DASHBOARD CABLE ASSEMBLY REPLACEMENT/REPAIR	7-64
7-12. DIMMER SWITCH REPLACEMENT	7-88
7-13. WTEC II TRANSMISSION ECU PUSHBUTTON SHIFT SELECTOR (TEPSS) DIMMER MODULE REPLACEMENT	7-89
7-14. ELECTRICAL GAGES REPLACEMENT	7-91
7-15. INSTRUMENT PANEL ASSEMBLY REPLACEMENT/REPAIR	7-93
7-16. LIGHTED INDICATOR DISPLAY REPLACEMENT/REPAIR	7-110
7-17. MAIN LIGHT SWITCH REPLACEMENT	7-112
7-18. ROCKER SWITCHES REPLACEMENT	7-114
7-19. START INHIBIT PUSHBUTTON SWITCH REPLACEMENT	7-119
7-20. STARTER PUSHBUTTON SWITCH REPLACEMENT	7-121
7-21. TACHOMETER REPLACEMENT	7-122
7-22. COOLANT TEMPERATURE LIGHT SWITCH REPLACEMENT	7-124
7-23. M1090/M1094 DUMP BODY SWITCH REPLACEMENT/ADJUSTMENT	7-127
7-24. FAN AND DIFFERENTIAL LOCK SOLENOIDS REPLACEMENT	7-131
7-25. FLASHER UNIT REPLACEMENT	7-134
7-26. TURN SIGNAL SWITCH REPLACEMENT	7-135
7-27. M1084/M1086 JUNCTION BOX ASSEMBLY REPLACEMENT/REPAIR	7-138
7-28. M1089 JUNCTION BOX ASSEMBLY REPLACEMENT/REPAIR	7-159
7-29. SHUNT REPLACEMENT	7-180
7-30. 100 AMP REVERSE POLARITY RELAY REPLACEMENT	7-184
7-31. FREQUENCY ECU REPLACEMENT	7-188
7-32. CRANE REMOTE CONTROL BOX REPAIR	7-190
7-33. M1089 TERMINAL BOARD ASSEMBLY REPLACEMENT	7-198
7-34. M1089 WRECKER CONTROL PANEL TOGGLE SWITCH REPLACEMENT	7-202
7-35. M1089 WRECKER REMOTE CONTROL BOX REPAIR	7-207
7-36. BACKUP LIGHT ASSEMBLY REPLACEMENT/REPAIR	7-211
7-37. BLACKOUT DRIVE LIGHT REPLACEMENT/REPAIR	7-217
7-38. CLEARANCE AND MARKER LIGHT ASSEMBLIES REPLACEMENT	7-219
7-39. COMPOSITE TAILLIGHT ASSEMBLY REPLACEMENT/REPAIR	7-225
7-40. COMPOSITE FRONT LIGHT ASSEMBLY REPLACEMENT/REPAIR	7-233
7-41. HEADLIGHT AND HOUSING REPLACEMENT/REPAIR/ADJUSTMENT	7-236
7-42. M1088/M1089 STATIONARY WORKLIGHT ASSEMBLY REPLACEMENT/REPAIR	7-240

7-43.	AUDIBLE ALARM REPLACEMENT	7-242
7-44.	AIR PRESSURE TRANSMITTER REPLACEMENT	7-244
7-45.	COOLANT TEMPERATURE GAGE SENSOR REPLACEMENT	7-246
7-46.	ENGINE SPEED SENSOR REPLACEMENT/ADJUSTMENT	7-248
7-47.	ETHER SENSOR REPLACEMENT	7-251
7-48.	OIL PRESSURE SWITCH REPLACEMENT	7-254
7-49.	OIL PRESSURE TRANSDUCER REPLACEMENT	7-256
7-50.	WATER TEMPERATURE SWITCH REPLACEMENT	7-258
7-51.	M1084/M1086 JACK CYLINDER PROXIMITY SENSOR REPLACEMENT	7-261
7-52.	TRANSMISSION ENGINE SPEED SENSOR REPLACEMENT	7-264
7-53.	HORN AND BRACKET REPLACEMENT	7-266
7-54.	BATTERY TESTER REPLACEMENT	7-269
7-55.	BATTERY/BATTERY CABLES REPLACEMENT	7-274
7-56.	BATTERY BOX REPLACEMENT	7-282
7-57.	DISCONNECTING/CONNECTING BATTERIES	7-288
7-58.	AUXILIARY PANEL CABLE ASSEMBLY REPLACEMENT	7-291
7-59.	CHEMICAL ALARM KIT CABLE ASSEMBLY REPLACEMENT	7-293
7-60.	CENTRAL TIRE INFLATION SYSTEM (CTIS) CABLE ASSEMBLY REPLACEMENT	7-294
7-61.	LEFT-HAND DOOR AND CAB MARKER LIGHTS CABLE ASSEMBLY REPLACEMENT	7-296
7-62.	M1093/M1094 CAB CLEARANCE AND MARKER LIGHTS LOWER CABLE ASSEMBLY REPLACEMENT	7-303
7-63.	M1093/M1094 CAB CLEARANCE AND MARKER LIGHTS UPPER CABLE ASSEMBLY REPLACEMENT	7-306
7-64.	RIGHT-HAND DOOR AND CAB MARKER LIGHTS CABLE ASSEMBLY REPLACEMENT	7-310
7-65.	STE/ICE-R CABLE ASSEMBLY REPLACEMENT	7-317
7-66.	CAB CLEARANCE MARKER LIGHTS CABLE ASSEMBLY REPLACEMENT	7-320
7-67.	WINDSHIELD WASHER PUMP ELECTROMAGNETIC INTERFERENCE (EMI) CABLE REPLACEMENT	7-325
7-68.	WINDSHIELD WIPER ELECTROMAGNETIC INTERFERENCE (EMI) CABLE REPLACEMENT	7-328
7-69.	WINDSHIELD WIPER ECU REPLACEMENT	7-330
7-70.	NATO POWER CABLE REPLACEMENT	7-331
7-71.	ALTERNATOR GROUND STRAP REPLACEMENT	7-334
7-72.	100 AMP ALTERNATOR TO REVERSE POLARITY RELAY 12 VDC CABLE REPLACEMENT	7-336
7-73.	100 AMP ALTERNATOR TO REVERSE POLARITY RELAY 24 VDC CABLE REPLACEMENT	7-340
7-74.	BATTERY TO 100 AMP REVERSE POLARITY RELAY 12 VDC CABLE REPLACEMENT	7-344
7-75.	BATTERY TO 100 AMP REVERSE POLARITY RELAY 24 VDC CABLE REPLACEMENT	7-346
7-76.	BATTERY TO SHUNT CABLE ASSEMBLY REPLACEMENT	7-349
7-77.	BATTERY TO STARTER CABLE ASSEMBLY REPLACEMENT	7-351
7-78.	CAB TO CHASSIS GROUND STRAP REPLACEMENT	7-355
7-79.	M1084/M1086 CRANE POWER CONTROL CABLE ASSEMBLY REPLACEMENT	7-357

Volume 4

7-80.	ENGINE CONTROL CABLE ASSEMBLY REPLACEMENT	7-365
7-81.	FRONT INTERVEHICULAR 12 VDC (7 Pin) CABLE REPLACEMENT	7-376
7-82.	FRONT LIGHTS CABLE ASSEMBLY REPLACEMENT	7-377
7-83.	M1089 WRECKER CONTROL PANEL WIRING HARNESS REPLACEMENT	7-389
7-84.	M1083/M1084/M1085/M1090/M1092/M1093/M1094/M1096 REAR LIGHTS CABLE ASSEMBLY REPLACEMENT	7-397
7-85.	M1084/M1086 BOOM DOWN LOCKOUT SOLENOID CABLE REPLACEMENT	7-430
7-86.	M1084/M1086 BOOM DOWN SOLENOID CABLE REPLACEMENT	7-434
7-87.	M1084/M1086 BOOM UP LOCKOUT SOLENOID CABLE REPLACEMENT	7-438
7-88.	M1084/M1086 BOOM UP SOLENOID CABLE REPLACEMENT	7-442

7-89.	M1084/M1086 CONTROL LOCKOUT SOLENOID CABLE REPLACEMENT	7-446
7-90.	M1084/M1086 CRANE POWER CABLE REPLACEMENT	7-450
7-91.	M1084/M1086 HOIST DOWN SOLENOID CABLE REPLACEMENT	7-454
7-92.	M1084/M1086 HOIST UP LOCKOUT SOLENOID CABLE REPLACEMENT	7-458
7-93.	M1084/M1086 HOIST UP SOLENOID CABLE REPLACEMENT	7-462
7-94.	M1084/M1086 LEFT JACK CYLINDER PROXIMITY SENSOR CABLE REPLACEMENT	7-466
7-95.	M1084/M1086 OVERLOAD LOCKOUT CABLE REPLACEMENT	7-470
7-96.	M1084/M1086 REMOTE CONTROL CABLE REPLACEMENT	7-474
7-97.	M1084/M1086 RIGHT JACK CYLINDER PROXIMITY SENSOR CABLE REPLACEMENT	7-477
7-98.	M1084/M1086 SWING CCW SOLENOID CABLE REPLACEMENT	7-481
7-99.	M1084/M1086 SWING CW SOLENOID CABLE REPLACEMENT	7-485
7-100.	M1084/M1086 SYSTEM SHUTDOWN SOLENOID CABLE REPLACEMENT	7-489
7-101.	M1084/M1086 TELESCOPE IN SOLENOID CABLE REPLACEMENT	7-493
7-102.	M1084/M1086 TELESCOPE OUT LOCKOUT SOLENOID CABLE REPLACEMENT	7-497
7-103.	M1084/M1086 TELESCOPE OUT SOLENOID CABLE REPLACEMENT	7-501
7-104.	M1086/M1088/M1089 REAR LIGHTS CABLE ASSEMBLY REPLACEMENT	7-505
7-105.	M1089 BOOM DOWN LOCKOUT SOLENOID CABLE REPLACEMENT	7-534
7-106.	M1089 BOOM DOWN SOLENOID CABLE REPLACEMENT	7-538
7-107.	M1089 BOOM UP LOCKOUT SOLENOID CABLE REPLACEMENT	7-542
7-108.	M1089 BOOM UP SOLENOID CABLE REPLACEMENT	7-546
7-109.	M1089 CONTROL PANEL POWER CABLE ASSEMBLY REPLACEMENT	7-550
7-110.	M1089 CRANE POWER CABLE REPLACEMENT	7-553
7-111.	M1089 HOIST DOWN SOLENOID CABLE REPLACEMENT	7-558
7-112.	M1089 HOIST UP LOCKOUT SOLENOID CABLE REPLACEMENT	7-562
7-113.	M1089 HOIST UP SOLENOID CABLE REPLACEMENT	7-566
7-114.	M1089 HYDRAULIC SYSTEM SOLENOID CABLE REPLACEMENT	7-570
7-115.	M1089 LEFT SIDE REMOTE CONTROL CABLE REPLACEMENT	7-574
7-116.	M1089 OVERLOAD LOCKOUT CABLE REPLACEMENT	7-578
7-117.	M1089 REMOTE CONTROL WIRING HARNESS REPLACEMENT	7-582
7-118.	M1089 RIGHT SIDE REMOTE CONTROL CABLE REPLACEMENT	7-585
7-119.	M1089 SWING CCW SOLENOID CABLE REPLACEMENT	7-588
7-120.	M1089 SWING CW SOLENOID CABLE REPLACEMENT	7-592
7-121.	M1089 TELESCOPE IN SOLENOID CABLE REPLACEMENT	7-596
7-122.	M1089 TELESCOPE OUT LOCKOUT SOLENOID CABLE REPLACEMENT	7-600
7-123.	M1089 TELESCOPE OUT SOLENOID CABLE REPLACEMENT	7-604
7-124.	M1090/M1094 DUMP CABLE ASSEMBLY REPLACEMENT	7-608
7-125.	M1090/M1094 DUMP POWER CABLE ASSEMBLY REPLACEMENT	7-612
7-126.	POWER DISTRIBUTION PANEL (PDP) TO CAB GROUND CABLE REPLACEMENT	7-619
7-127.	POWER TAKE-OFF (PTO) CABLE ASSEMBLY REPLACEMENT	7-621
7-128.	REAR INTERVEHICULAR 12 VDC (7 Pin) CABLE REPLACEMENT	7-628
7-129.	REAR INTERVEHICULAR 24 VDC (12 Pin) CABLE REPLACEMENT	7-630
7-130.	100 AMP REVERSE POLARITY RELAY TO POWER DISTRIBUTION (PDP) PANEL 12 VDC CABLE REPLACEMENT	7-631
7-131.	100 AMP REVERSE POLARITY RELAY TO POWER DISTRIBUTION (PDP) PANEL 24 VDC CABLE REPLACEMENT	7-637
7-132.	START AND CHARGING CABLE ASSEMBLY REPLACEMENT	7-643
7-133.	STARTER TO CHASSIS GROUND CABLE REPLACEMENT	7-658
7-134.	STARTER TO SHUNT 24 VDC CABLE REPLACEMENT	7-661
7-135.	WINCH CONTROL VALVE CABLE ASSEMBLY REPLACEMENT	7-665
7-136.	TRANSMISSION AUXILIARY OIL COOLER FAN CABLE ASSEMBLY REPLACEMENT	7-670
7-137.	WTEC II CAB TRANSMISSION HARNESS REPLACEMENT	7-685
7-138.	WTEC III CAB TRANSMISSION HARNESS REPLACEMENT	7-691
7-139.	M1088 INTERMEDIATE INTERVEHICULAR 12 VDC (7 PIN) (CABLE REPLACEMENT	7-696

7-140. M1088 INTERMEDIATE INTERVEHICULAR 24 VDC (12 PIN) CABLE REPLACEMENT	7-698
7-141. LOW PRESSURE TRANSMITTER REPLACEMENT	7-700
7-142. M1089 WINCH CONTROL WIRING HARNESS REPLACEMENT	7-703
7-143. M1084/M1086 JUNCTION BOX MODIFICATION	7-708
7-144. M1089 JUNCTION BOX MODIFICATION	7-715

Section I. INTRODUCTION

7-1. INTRODUCTION

This chapter contains maintenance instructions for replacing, repairing, and adjusting electrical components authorized by the Maintenance Allocation Chart (MAC) at the Unit Maintenance level.

Section II. MAINTENANCE PROCEDURES

7-2. 100 AMP ALTERNATOR REPLACEMENT	
This task covers:	
a. Removal b. Installation	c. Follow-On Maintenance
INITIAL SETUP	
Equipment Conditions Batteries disconnected (para 7-57). Alternator belts removed (para 7-3).	Materials/Parts Dispenser, Pressure Sensitive Adhesive Tape (Item 20, Appendix D) Nut, Self-Locking (Item 153, Appendix G)
Tools and Special Tools Tool Kit, Genl Mech (Item 46, Appendix C) Vise, Machinist (Item 48, Appendix C) Caps, Vise Jaw (Item 4, Appendix C) Wrench, Torque, 0-175 lb-ft (Item 58, Appendix C) Wrench, Torque, 0-200 lb-in. (Item 59, Appendix C) (Socket Set, Socket Wrench (Item 36, Appendix C)	Personnel Required (2)

a. Removal.

NOTE

Tag wires and connection points prior to disconnecting.

- (1) Remove screw (1), lockwasher (2), terminal lug TL5 (3), washer (4), and ground strap (5) from alternator (6).
- (2) Position washer (4), lockwasher (2), and screw (1) on alternator (6).
- (3) Lift dust boot (7) on terminal lug TL60 (8).
- (4) Remove self-locking nut (9), washer (10), terminal lug TL60 (8), and two washers (11) from alternator (6).
- (5) Position two washers (11), washer (10), and self-locking nut (9) on alternator (6).

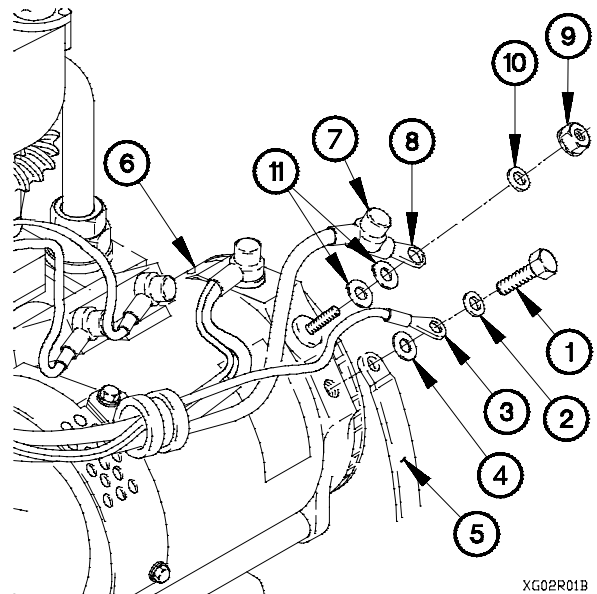

XG02R01B

7-2. 100 AMP ALTERNATOR REPLACEMENT (CONT)

- (6) Remove screw (13), washer (14), and clamp (15) from alternator (6).
- (7) Lift dust boot (16) on terminal lug TL2 (17).
- (8) Remove self-locking nut (18), washer (19), terminal lugs TL2 (17) and TL6 (21), and two washers (22) from alternator (6).
- (9) Position two washers (22), washer (19), and self-locking nut (18) on alternator (6).

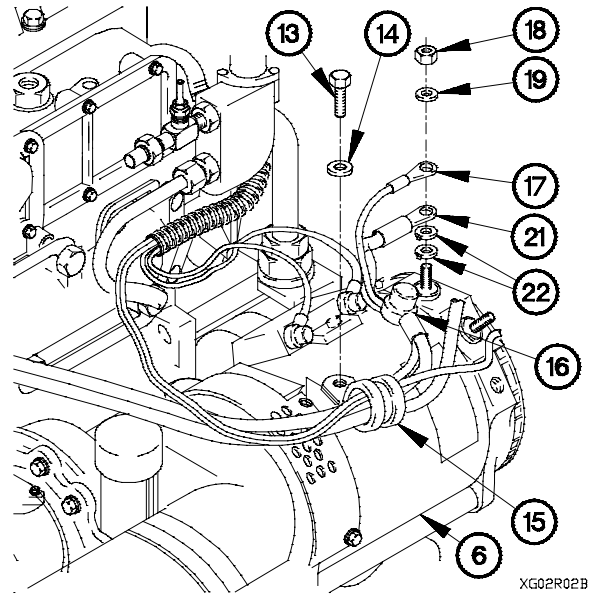

XG02R02B

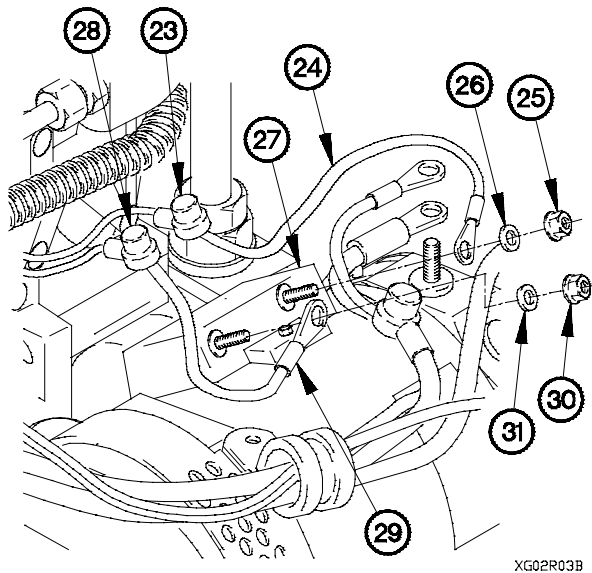

XG02R03B

- (10) Lift dust boot (23) on terminal lug TL35 (24).
- (11) Remove self-locking nut (25), washer (26), and terminal lug TL35 (24) from voltage regulator (27).
- (12) Position washer (26) and self-locking nut (25) on voltage regulator (27).
- (13) Lift dust boot (28) on terminal lug TL110 (29).
- (14) Remove self-locking nut (30), washer (31), and terminal lug TL110 (29) from voltage regulator (27).
- (15) Position washer (31) and self-locking nut (30) on voltage regulator (27).

- (16) Remove nut (32), washer (33), screw (34), and washer (35) from alternator (6).
- (17) Remove self-locking nut (36), screw (37), and washer (38) from alternator (6). Discard self-locking nut.

WARNING

Alternator weighs approximately 50 lbs (23 kgs). The aid of an assistant is required to remove alternator. Failure to comply may result in injury to personnel.

NOTE

Step (18) requires the aid of an assistant.

- (18) Remove alternator (6) from support bracket (39).

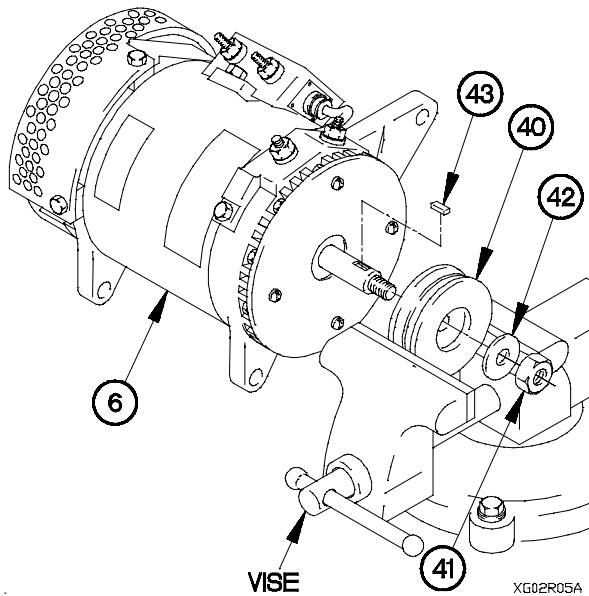
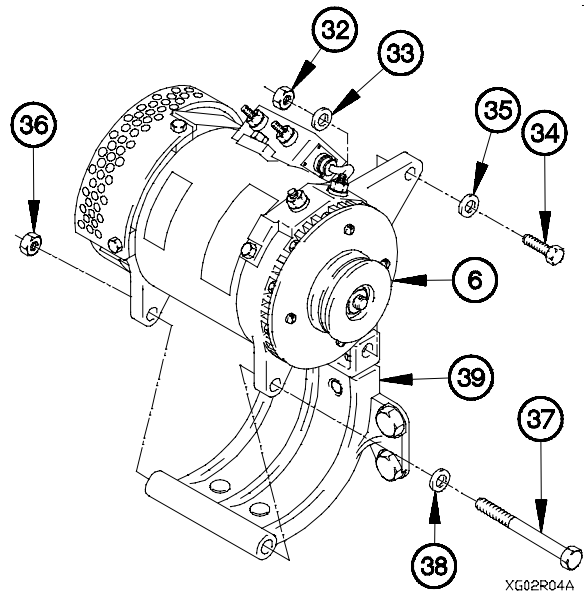

CAUTION

Alternator pulley must be positioned in a vise equipped with vise jaw caps when loosening self-locking nut. Failure to comply may result in damage to equipment.

- (19) Position pulley (40) in vise.
- (20) Loosen self-locking nut (41).
- (21) Remove pulley (40) from vise.
- (22) Remove self-locking nut (41), washer (42), pulley (40), and key (43) from alternator (6).
- (23) Position washer (42) and self-locking nut (41) on alternator (6).

7-2. 100 AMP ALTERNATOR REPLACEMENT (CONT)

b. Installation.

- (1) Remove self-locking nut (1) and washer (2) from alternator (3).
- (2) Position key (4) and pulley (5) on alternator (3) with washer (2) and self-locking nut (1).

CAUTION

Alternator pulley must be positioned in a vise equipped with vise jaw caps when tightening self-locking nut. Failure to comply may result in damage to equipment.

- (3) Position pulley (5) in vise.
- (4) Tighten self-locking nut (1) to 120 lb-ft (163 N·m).
- (5) Remove pulley (5) from vise.

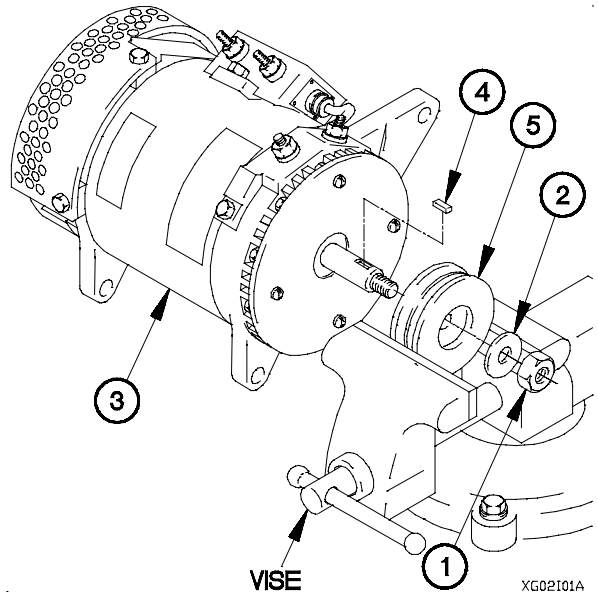

WARNING

Alternator weighs approximately 50 lbs (23 kgs). The aid of an assistant is required to install alternator. Failure to comply may result in injury to personnel.

NOTE

Step (6) requires the aid of an assistant.

- (6) Position alternator (3) on support bracket (6) with washer (7), screw (8), and self-locking nut (9).
- (7) Position washer (10), screw (11), washer (12) and nut (13) on alternator (3).
- (8) Tighten nut (13) to 18-22 lb-ft (24-30 N·m).
- (9) Tighten self-locking nut (9) to 44-56 lb-ft (60-76 N·m).

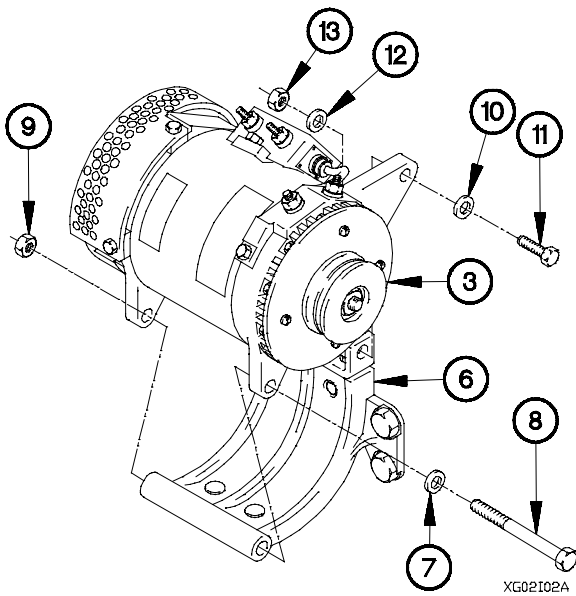

- (10) Remove self-locking nut (14) and washer (15) from voltage regulator (16).
- (11) Position terminal lug TL110 (17), washer (15), and self-locking nut (14) on voltage regulator (16).
- (12) Tighten self-locking nut (14) to 20 lb-in. (2.5 N·m).
- (13) Position dust boot (18) on terminal lug TL110 (17).
- (14) Remove self-locking nut (19) and washer (20) from voltage regulator (16).
- (15) Position terminal lug TL35 (21), washer (20), and self-locking nut (19) on voltage regulator (16).
- (16) Tighten self-locking nut (19) to 25 lb-in. (3 N·m).
- (17) Position dust boot (22) on terminal lug TL35 (21).

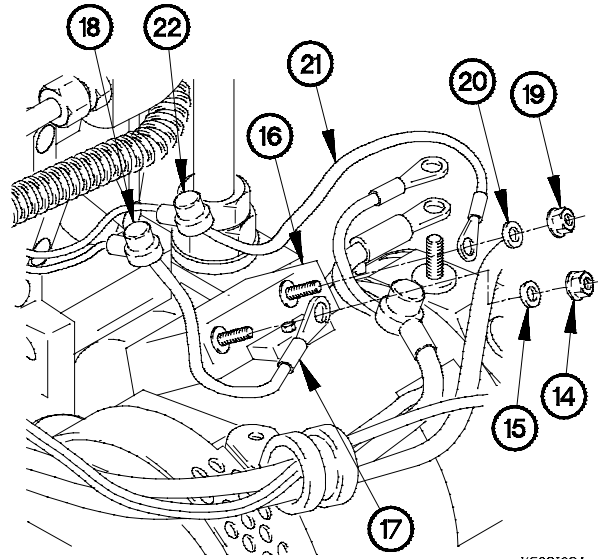

XG02103A

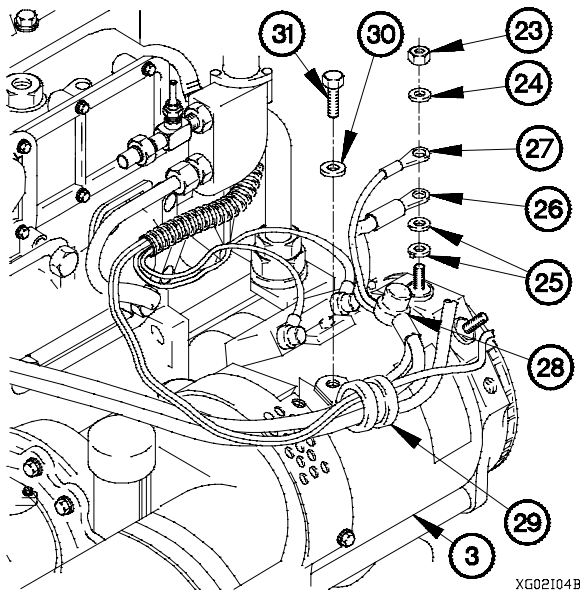

XG02104B

- (18) Remove self-locking nut (23), washer (24), and two washers (25) from alternator (3).
- (19) Position two washers (25), terminal lugs TL6 (26) and TL2 (27), washer (24), and self-locking nut (23) on alternator (3).
- (20) Tighten self-locking nut (23) to 80 lb-in. (9 N·m).
- (21) Position dust boot (28) on terminal lug TL2 (27).
- (22) Position clamp (29), washer (30), and screw (31) on alternator (3).
- (23) Tighten screw (31) to 80 lb-in. (9 N·m).

7-2. 100 AMP ALTERNATOR REPLACEMENT (CONT)

- (24) Remove self-locking nut (32), washer (33), and two washers (34) from alternator (3).
- (25) Position two washers (34), terminal lug TL60 (35), washer (33), and self-locking nut (32) on alternator (3).
- (26) Tighten self-locking nut (32) to 80 lb-in. (9 N·m).
- (27) Position dust boot (36) on terminal lug TL60 (35).
- (28) Remove screw (37), lockwasher (38), and washer (39) from alternator (3).
- (29) Position ground strap (40), washer (39), and terminal lug TL5 (41) on alternator (3) with lockwasher (38) and screw (37).
- (30) Tighten screw (37) to 80 lb-in. (9 N·m).

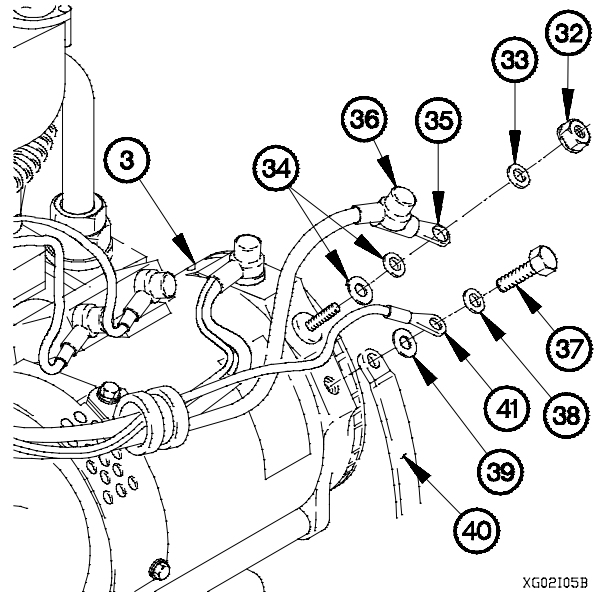

XG02105B

c. Follow-On Maintenance.

- (1) Install alternator belts (para 7-3).
- (2) Connect batteries (para 7-57).
- (3) Start engine (TM 9-2320-366-10-1).
- (4) Check alternator operation (TM 9-2320-366-10-1).
- (5) Shut down engine (TM 9-2320-366-10-1).

End of Task.

7-3. ALTERNATOR BELTS REPLACEMENT

This task covers:

- a. Removal
- b. Installation
- c. Follow-On Maintenance

INITIAL SETUP

Equipment Conditions

- Engine shut down (TM 9-2320-366-10-1).
- Cab raised (TM 9-2320-366-10-1).
- Air tanks drained (TM 9-2320-366-10-1).

Tools and Special Tools

- Tool Kit, Genl Mech (Item 46, Appendix C)
- Gage, Belt Tension (Item 19, Appendix B)
- Wrench, Torque, 0-175 lb-ft (Item 58, Appendix C)

Personnel Required

(2)

CAUTION

Alternator belts must be replaced as a pair. Failure to comply may result in damage to equipment.

a. Removal.

- (1) Disconnect air hose (1) from fan clutch (2).

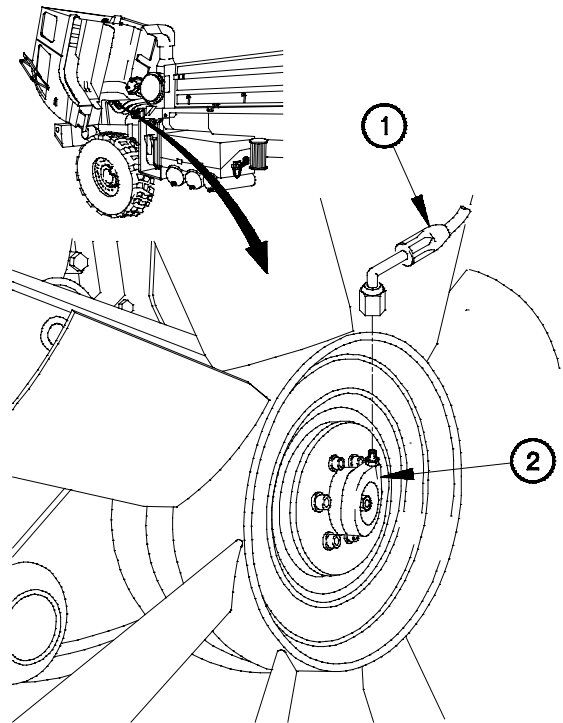

XG03R011

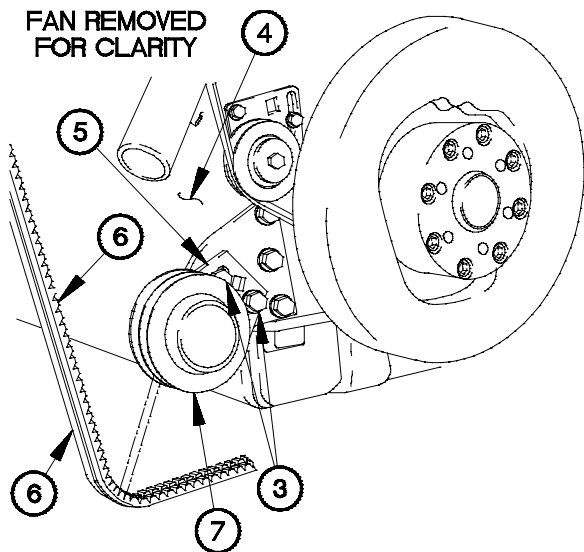

XG03R021

- (2) Loosen two screws (3) on front of engine block (4).
- (3) Move tension bracket (5) up.
- (4) Remove two alternator belts (6) from pulley (7).

7-3. ALTERNATOR BELTS REPLACEMENT (CONT)

b. Installation.

(1) Position two alternator belts (1) on pulley (2).

CAUTION

Tension bracket adjustment varies for new or reinstalled belts. New belts must be adjusted to 110-130 lbs (489-478 N), reinstalled belts must be adjusted to 80-100 lbs (356-444 N). Failure to comply may result in early belt failures.

NOTE

- Steps (2) and (3) require the aid of an assistant.
- Use square hole in tension bracket to apply tension to alternator belts.

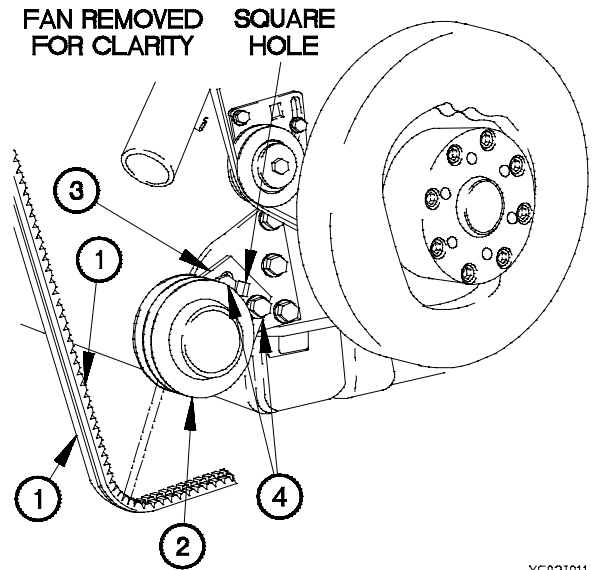

XG031011

(2) Push tension bracket (3) down until belt tension gage indicates correct tension for new or reinstalled belts (1).

(3) Maintain belt tension and tighten two screws (4).

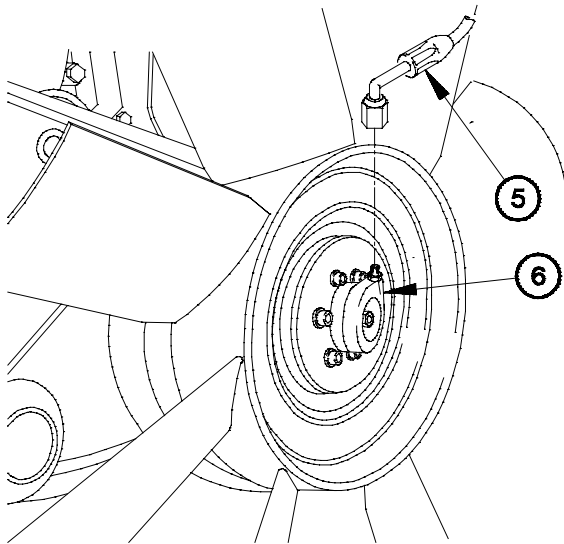

XG031021

(4) Connect air hose (5) to fan clutch (6).

- (5) Lower cab (TM 9-2320-366-10-1).
- (6) Start engine and run for five minutes.
- (7) Shut down engine (TM 9-2320-366-10-1).
- (8) Raise cab (TM 9-2320-366-10-1).

NOTE

Check belt tension for proper tension for new or reinstalled belts.

- (9) Loosen one screw (4) and readjust tension bracket (3) for new or reinstalled belts, as required.
- (10) Tighten two screws (4) to 47 lb-ft (64 N·m).

FAN REMOVED
FOR CLARITY

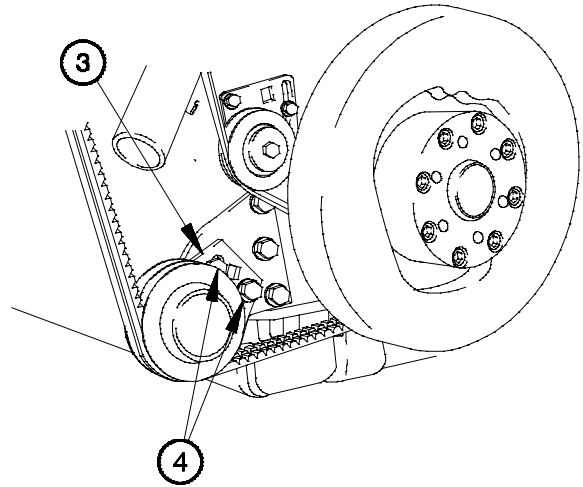

XG03I031

c. Follow-On Maintenance.

- (1) Lower cab (TM 9-2320-366-10-1).
- (2) Start engine (TM 9-2320-366-10-1).
- (3) Check VOLTS gage for indication of 22-28 volts (TM 9-2320-366-10-1).
- (4) Shut down engine (TM 9-2320-366-10-1).

End of Task.

7-4. ALTERNATOR BRACKETS REPLACEMENT	
This task covers:	
a. Support Brackets Removal b. Support Brackets Installation	c. Belt Take-Up Bracket Removal d. Belt Take-Up Bracket Installation e. Follow-On Maintenance
INITIAL SETUP	
Equipment Conditions 100 amp alternator removed, if equipped (para 7-2). 200 amp alternator removed, if equipped (para 20-45).	Material/Parts Sealing Compound (Item 57, Appendix D) Nut, Self-Locking (Item 167, Appendix G)
Tools and Special Tools Goggles, Industrial (Item 15, Appendix C) Tool Kit, Genl Mech (Item 46, Appendix C) Wrench, Torque, 0-175 lb-ft (Item 58, Appendix C) Gage, Belt Tension (Item 19, Appendix B)	Personnel Required (2)

a. Support Brackets Removal.

NOTE

Note location of different size screws for installation.

- (1) Remove two screws (1), washers (2), and belt adjusting arm (3) from alternator bracket (4).

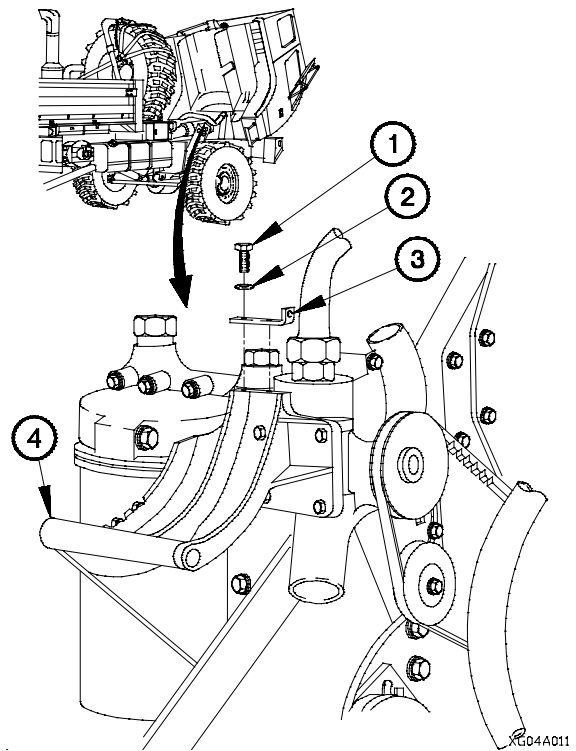

- (2) Remove two screws (5) and washers (6) from alternator support bracket (7).
- (3) Remove three screws (8) from alternator bracket (4).
- (4) Remove self-locking nut (9) and alternator bracket (4) from thermostat housing (10). Discard self-locking nut.

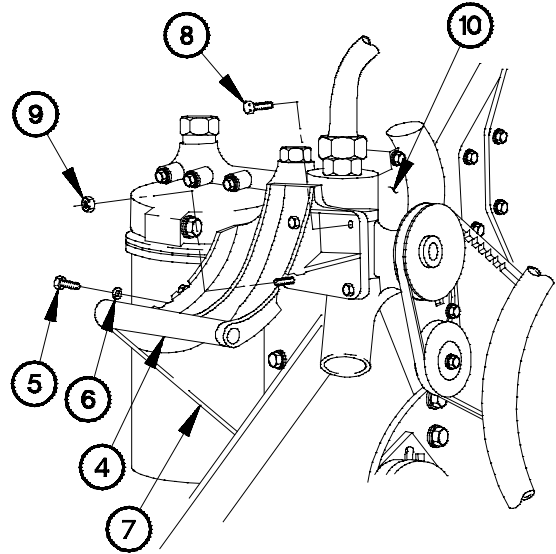

XG04A021

- (5) Remove two screws (11) and alternator support bracket (7) from engine block (12).

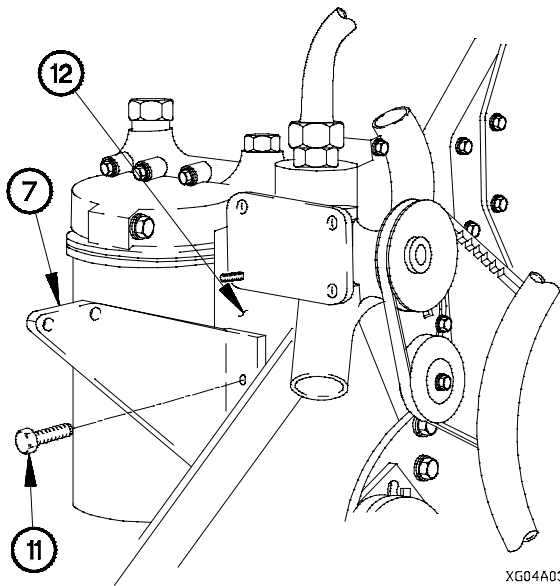

XG04A031

b. Support Brackets Installation.

- (1) Position alternator support bracket (1) on engine block (2) with two screws (3).
- (2) Tighten two screws (3) to 121-147 lb-ft (164-200 N·m).

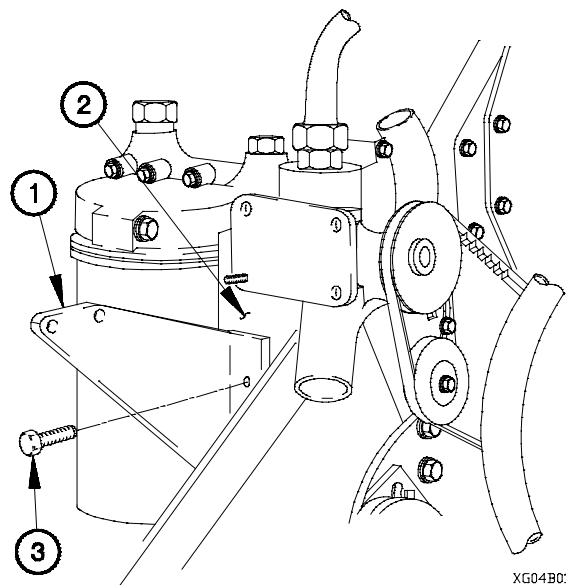

XG04B011

7-4. ALTERNATOR BRACKETS REPLACEMENT (CONT)

WARNING

Adhesive Sealant MIL-S-46163 can damage your eyes. Wear safety goggles/glasses when using; avoid contact with eyes. If sealant contacts eyes, flush eyes with water and get immediate medical attention. Failure to comply may result in injury to personnel.

- (3) Apply sealing compound to threads of three screws (4) and stud (5).
- (4) Position alternator bracket (6) on thermostat housing (7) with three screws (4).
- (5) Install self-locking nut (8) on stud (5).
- (6) Tighten three screws (4) to 18-22 lb-ft (24-30 N·m).
- (7) Position two washers (9) and screws (10) in alternator bracket (6).
- (8) Tighten two screws (10) to 121-147 lb-ft (164-200 N·m).

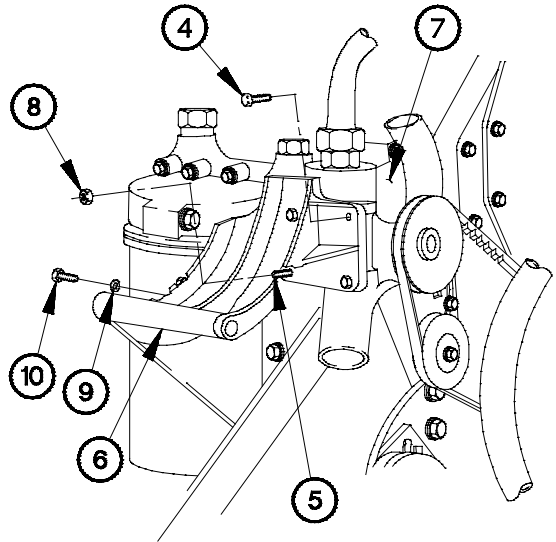

XG04B021

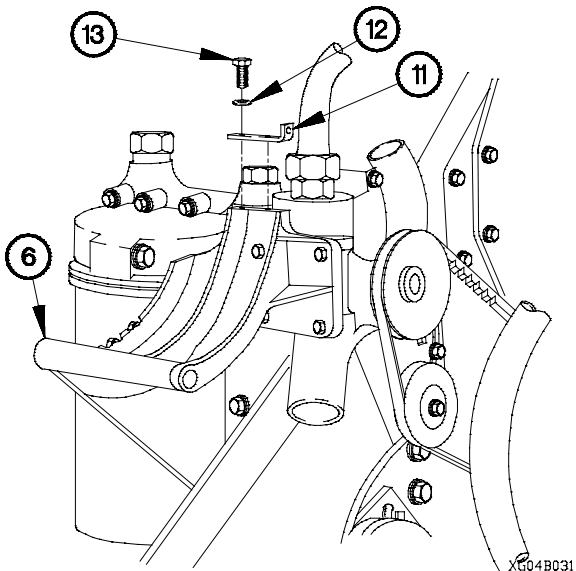

- (9) Position belt adjusting arm (11) on alternator bracket (6) with two washers (12) and screws (13).
- (10) Tighten two screws (13) to 18-22 lb-ft (24-30 N·m).

XG04B031

c. Belt Take-Up Bracket Removal.

WARNING

Wear appropriate eye protection when working under vehicle due to the possibility of falling debris. Failure to comply may result in injury to personnel.

- (1) Loosen two screws (1) on water pump pulley bracket (2).
- (2) Position water pump pulley bracket (2) for access to three screws (3).

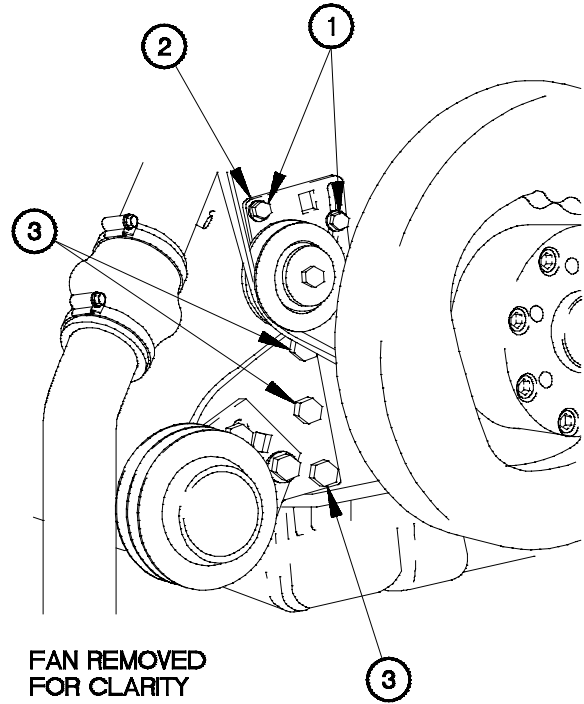

XG04C011

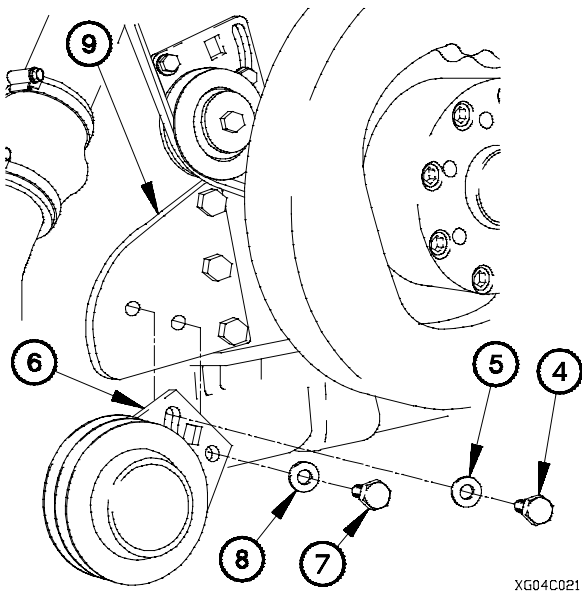

XG04C021

- (3) Remove screw (4) and washer (5) from alternator belt take-up plate (6).
- (4) Remove screw (7), washer (8), and alternator belt take-up plate (6) from alternator belt take-up mounting bracket (9).

- (5) Remove three screws (3) from alternator belt take-up mounting bracket (9).
- (6) Remove two screws (10) and alternator belt take-up mounting bracket (9) from engine front cover (11).

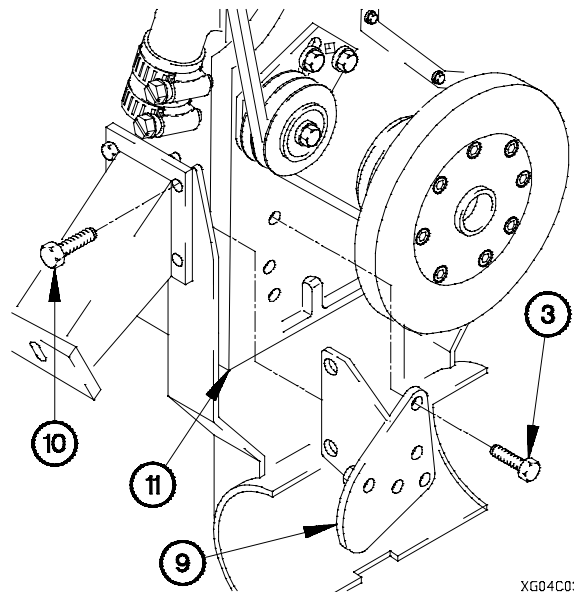

XG04C031

7-4. ALTERNATOR BRACKETS REPLACEMENT (CONT)

d. Belt Take-Up Bracket Installation.

- (1) Position alternator belt take-up mounting bracket (1) on engine front cover (2) with two screws (3).
- (2) Position three screws (4) in engine front cover (2).
- (3) Tighten two screws (3) to 121-147 lb-ft (164-200 N-m).
- (4) Tighten three screws (4) to 106-130 lb-ft (144-176 N-m).

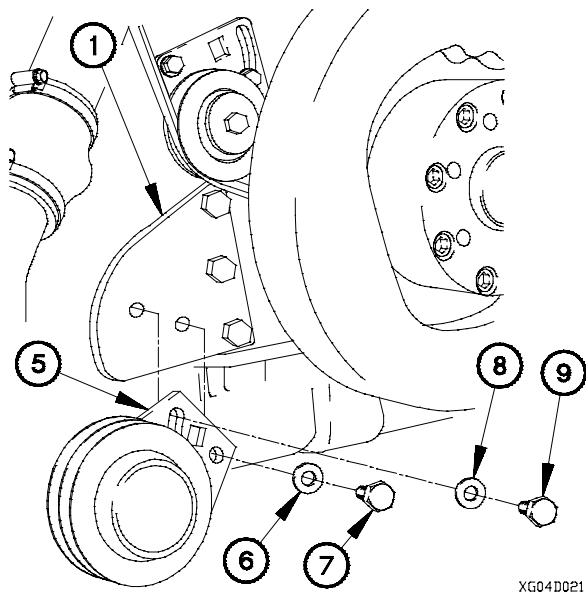
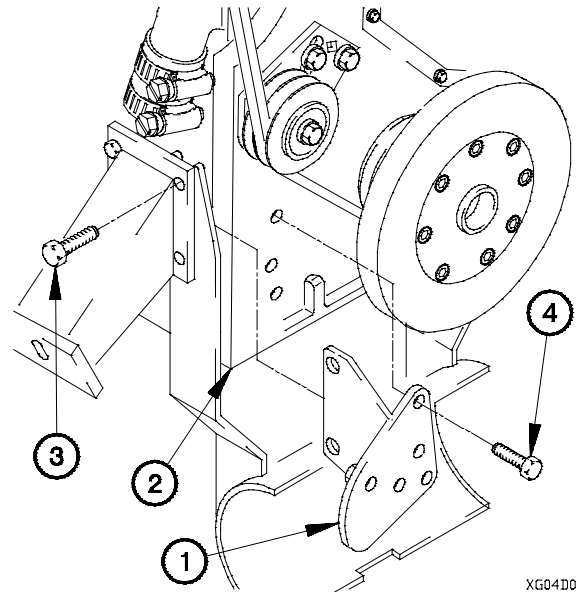

- (5) Install alternator belt take-up plate (5) on alternator belt take-up mounting bracket (1) with washer (6) and screw (7).
- (6) Install washer (8) and screw (9) in alternator belt take-up plate (5).

NOTE

- Steps (7) and (8) require the aid of an assistant.
- Use square hole in water pump belt pulley bracket to apply and maintain tension on water pump belt while adjusting belt tension.

- (7) Adjust tension on water pump belt (10) to 80-100 lbs (356-444 N).
- (8) Tighten two screws (11) to 35 lb-ft (47 N-m).

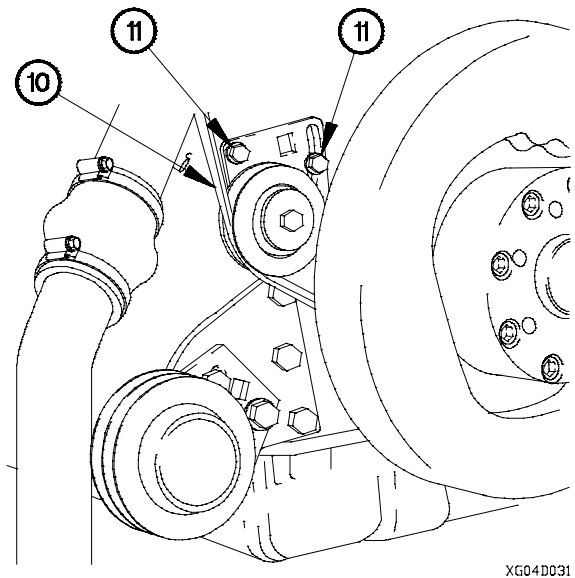

e. Follow-On Maintenance.

- (1) Install 200 amp alternator, if equipped (para 20-45).
- (2) Install 100 amp alternator, if equipped (para 7-2).
- (3) Start engine (TM 9-2320-366-10-1).
- (4) Check VOLTS gage for charge indication (TM 9-2320-366-10-1).
- (5) Shut down engine (TM 9-2320-366-10-1).

End of Task.

7-5. 100 AMP VOLTAGE REGULATOR REPLACEMENT	
This task covers:	
a. Removal b. Installation	c. Follow-On Maintenance
INITIAL SETUP	
Equipment Conditions Cab raised (TM 9-2320-366-10-1). Batteries disconnected (para 7-57).	Materials/Parts Dispenser, Pressure Sensitive Adhesive Tape (Item 20, Appendix D) Sealing Compound (Item 59, Appendix D) Lockwasher (2) (Item 104, Appendix G) Nut, Self-Locking (Item 143, Appendix G) Nut, Self-Locking (Item 144, Appendix G)
Tools and Special Tools Tool Kit, Genl Mech (Item 46, Appendix C) Wrench, Torque, 0-200 lb-in. (Item 59, Appendix C) Socket Set, Socket Wrench (Item 34, Appendix C)	

a. Removal.

NOTE

Tag wires and connection points prior to disconnecting.

- (1) Lift dust boot (1) on terminal lug TL35 (2).
- (2) Remove self-locking nut (3), washer (4), and terminal lug TL35 (2) from voltage regulator (5). Discard self-locking nut.
- (3) Lift dust boot (6) on terminal lug TL110 (7).
- (4) Remove self-locking nut (8), washer (9), and terminal lug TL110 (7) from voltage regulator (5). Discard self-locking nut.

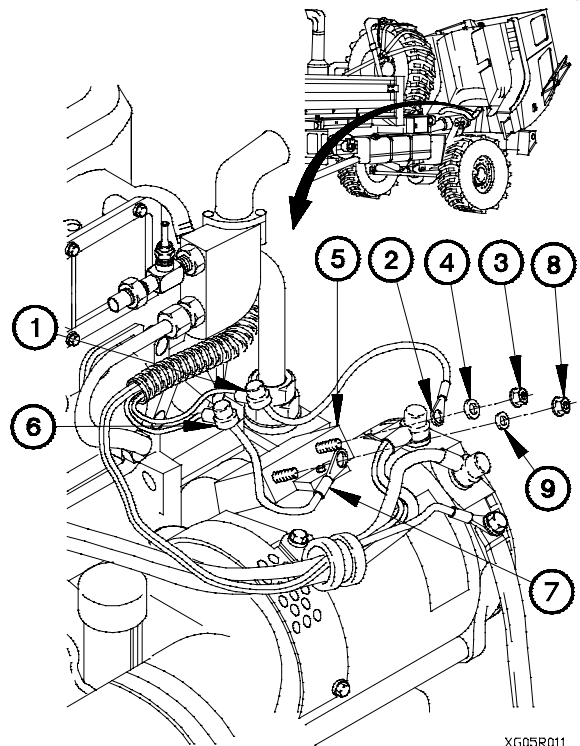

XG05R011

- (5) Disconnect voltage regulator connector (10) from voltage regulator (5).
- (6) Remove two screws (11), lockwashers (12), and voltage regulator (5) from alternator (13). Discard lockwashers.

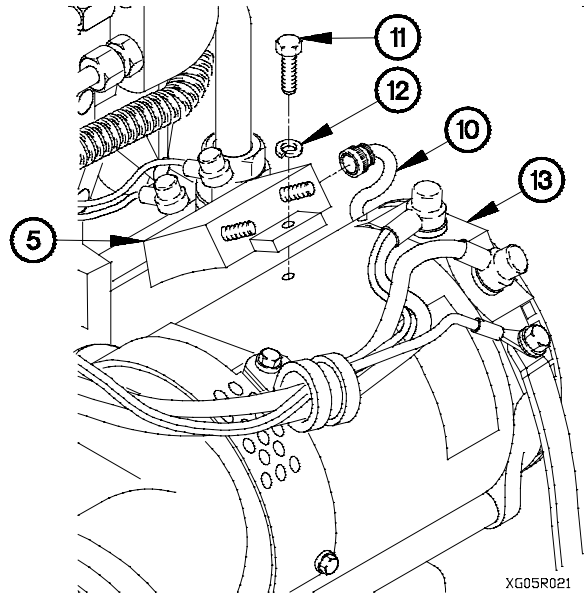

b. Installation.

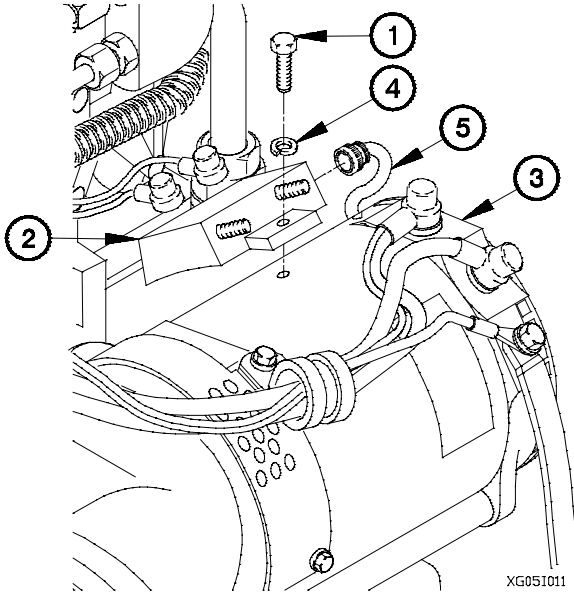

WARNING

Adhesives, solvents, and sealing compounds can burn easily, can give off harmful vapors, and are harmful to skin and clothing. Keep away from open fire and use in a well-ventilated area. If adhesive, solvent, or sealing compound gets on skin or clothing, wash immediately with soap and water. Failure to comply may result in injury to personnel.

- (1) Apply sealing compound to threads of two screws (1).
- (2) Position voltage regulator (2) on alternator (3) with two lockwashers (4) and screws (1).
- (3) Tighten two screws (1) to 65 lb-in. (7 N·m).
- (4) Connect voltage regulator connector (5) to voltage regulator (2).

7-5. 100 AMP VOLTAGE REGULATOR REPLACEMENT (CONT)

- (5) Position terminal lug TL110 (6) on voltage regulator (2) with washer (7), and self-locking nut (8).
- (6) Tighten self-locking nut (8) to 25 lb-in (3 N·m).
- (7) Position dust boot (9) on terminal lug TL110 (6).
- (8) Position terminal lug TL35 (10) on voltage regulator (2) with washer (11), and self-locking nut (12).
- (9) Tighten self-locking nut (12) to 25 lb-in. (3 N·m).
- (10) Position dust boot (13) on terminal lug TL35 (10).

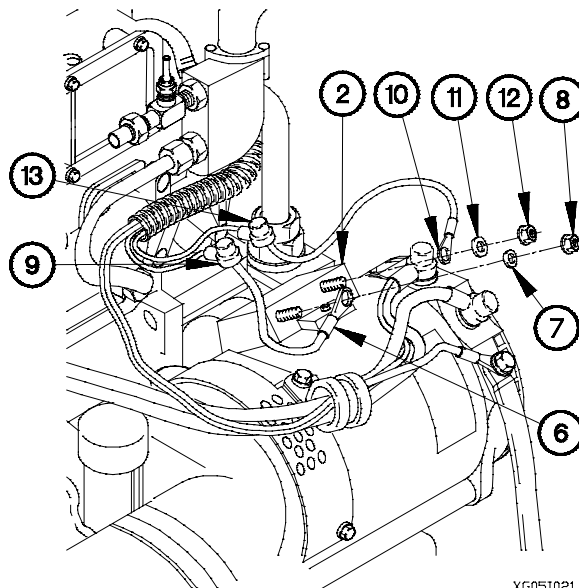

XG051021

c. Follow-On Maintenance.

- (1) Lower cab (TM 9-2320-366-10-1).
- (2) Connect batteries (para 7-57).
- (3) Start engine (TM 9-2320-366-10-1).
- (4) Check VOLTS gage for charge indication (TM 9-2320-366-10-1).
- (5) Shut down engine (TM 9-2320-366-10-1).

End of Task.

7-6. AUXILIARY STARTER SOLENOID REPLACEMENT

This task covers:

- a. Removal
- b. Installation
- c. Follow-On Maintenance

INITIAL SETUP

Equipment Conditions

Batteries disconnected (para 7-57).
Cab raised (TM 9-2320-366-10-1).

Tools and Special Tools

Tool Kit, Genl Mech (Item 46, Appendix C)
Wrench, Torque, 0-200 lb-in. (Item 59, Appendix C)
Socket Set, Socket Wrench (Item 36, Appendix C)

Materials/Parts

Dispenser, Pressure Sensitive Adhesive Tape (Item 20, Appendix D)
Adhesive (Item 8, Appendix D)
Lockwasher (2) (Item 87, Appendix G)
Lockwasher (2) (Item 89, Appendix G)
Nut, Self-Locking (2) (Item 128, Appendix G)

a. Removal.

NOTE

Tag wires and connection points prior to disconnecting.

- (1) Remove adhesive, two nuts (1), lockwashers (2), terminal lugs TL9 (3) and TL24 (4) from auxiliary starter solenoid (5). Discard lockwashers.

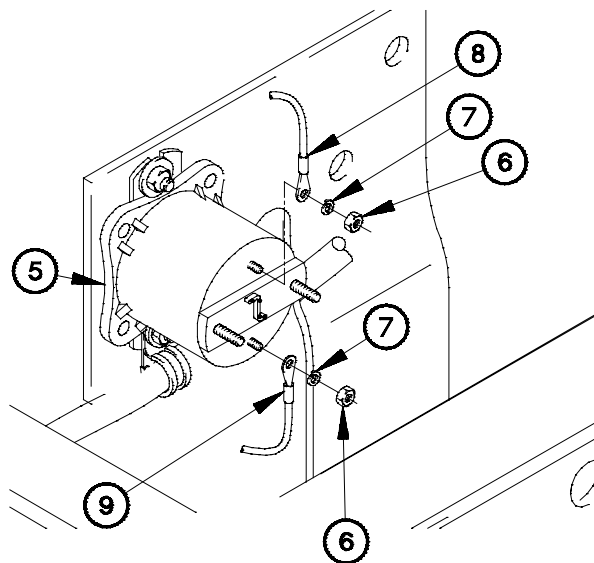
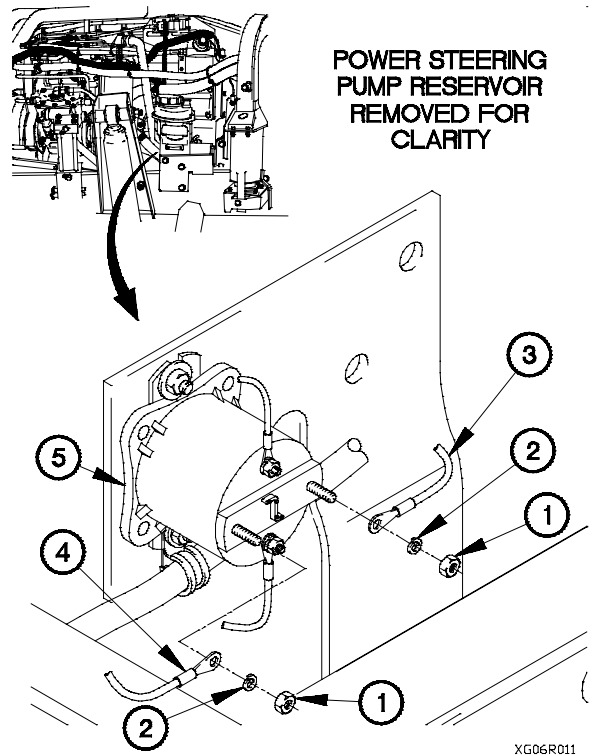

- (2) Remove adhesive, two nuts (6), lockwashers (7), terminal lugs TL23 (8) and TL33 (9) from auxiliary starter solenoid (5). Discard lockwashers.

7-6. AUXILIARY STARTER SOLENOID REPLACEMENT (CONT)

NOTE

Perform steps (3) and (4) on vehicle serial number 7413 and higher, and vehicle serial numbers 0001 through 7412 which have previously had an auxiliary starter solenoid replaced.

- (3) Remove self-locking nut (10), washer (11), and screw (12) from bracket (13). Discard self-locking nut.
- (4) Remove self-locking nut (14), washer (15), clamp (16), screw (17), and auxiliary starter solenoid (5) from bracket (13). Discard self-locking nut.

NOTE

Perform step (5) on vehicle serial numbers 0001 through 7412 which have not previously had an auxiliary starter solenoid replaced.

- (5) Remove self-locking nuts (10 and 14), washers (11 and 15), screws (12 and 17), and auxiliary starter solenoid (5) from bracket (13). Discard self-locking nuts.

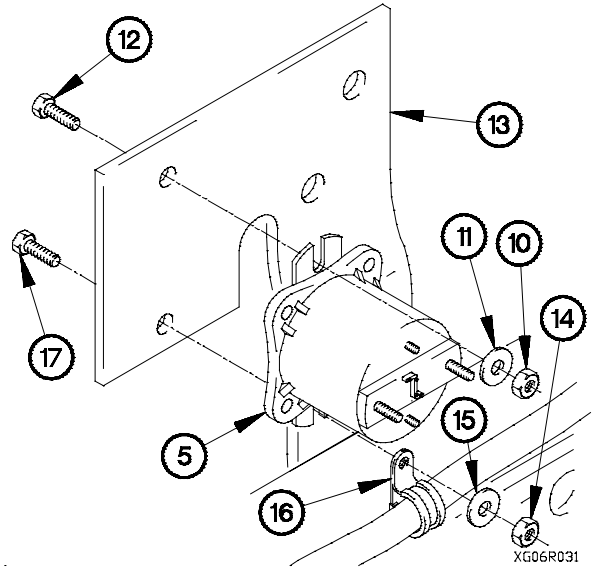

b. Installation.

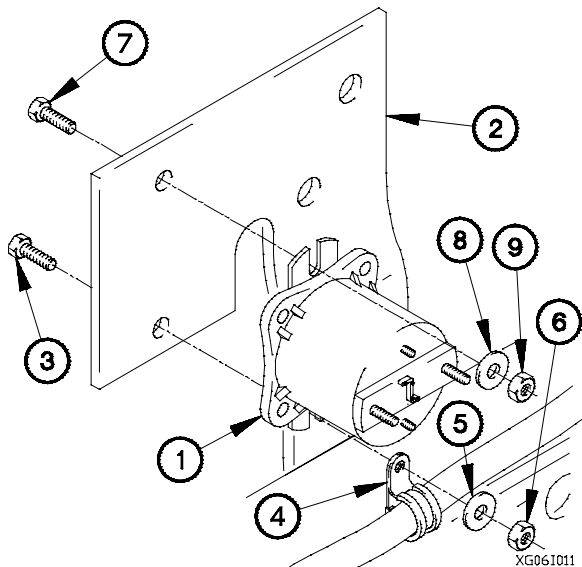

- (1) Position auxiliary starter solenoid (1) on bracket (2) with screw (3), clamp (4), washer (5), and self-locking nut (6).
- (2) Position screw (7), washer (8), and self-locking nut (9) in bracket (2).
- (3) Tighten self-locking nuts (6 and 9) to 96-120 lb-in. (11-14 N·m).

- (4) Install terminal lugs TL33 (10) and TL23 (11) on auxiliary starter solenoid (1) with two lockwashers (12) and nuts (13).

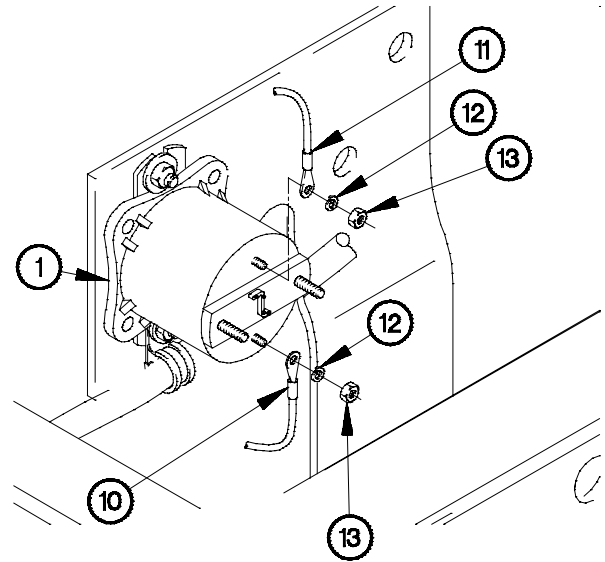

XG06I021

- (5) Install terminal lugs TL24 (14) and TL9 (15) on auxiliary starter solenoid (1) with two lockwashers (16) and nuts (17).

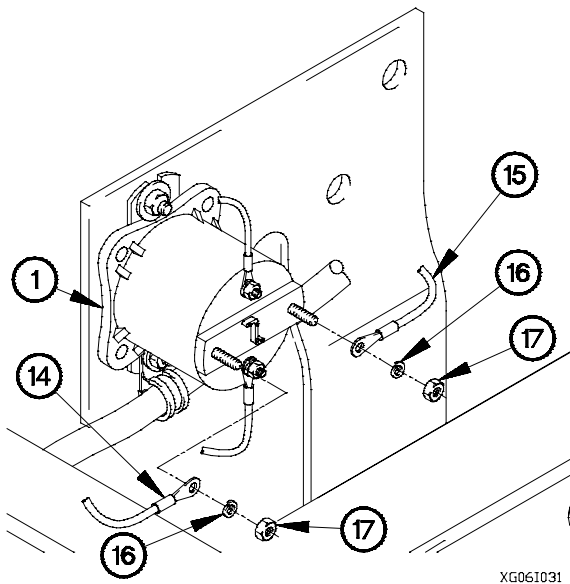

XG06I031

WARNING

Adhesives, solvents, and sealing compounds can burn easily, can give off harmful vapors, and are harmful to skin and clothing. Keep away from open fire and use in a well-ventilated area. If adhesive, solvent, or sealing compound gets on skin or clothing, wash immediately with soap and water. Failure to comply may result in injury to personnel.

- (6) Apply adhesive on nuts (13 and 17) and terminal lugs TL33 (10), TL23 (11), TL24 (14), and TL9 (15).

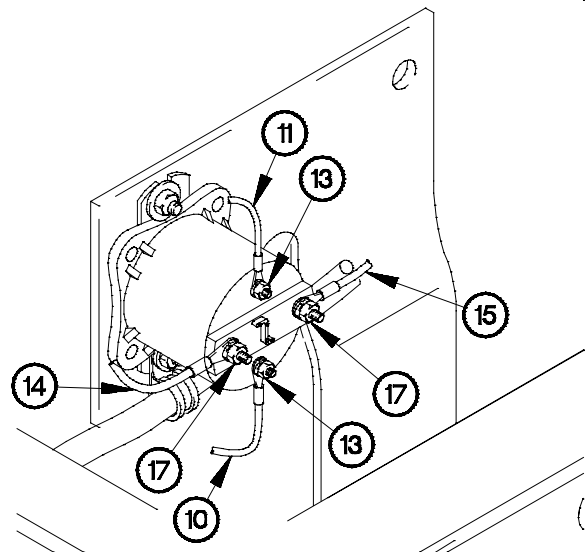

XG06I041

7-6. AUXILIARY STARTER SOLENOID REPLACEMENT (CONT)

c. Follow-On Maintenance.

- (1) Connect batteries (para 7-57).
- (2) Lower cab (TM 9-2320-366-10-1).
- (3) Start engine (TM 9-2320-366-10-1).
- (4) Shut down engine (TM 9-2320-366-10-1).

End of Task.

7-7. STARTING MOTOR REPLACEMENT

This task covers:

- a. Removal
- b. Installation
- c. Follow-On Maintenance

INITIAL SETUP

Equipment Conditions

Cab raised (TM 9-2320-366-10-1).
Batteries disconnected (para 7-57).

Tools and Special Tools

Goggles, Industrial (Item 15, Appendix C)
Tool Kit, Genl Mech (Item 46, Appendix C)
Wrench, Torque, 0-175 lb-ft (Item 58, Appendix C)
Sling, Endless (Item 32, Appendix C)
Wrench Set, Socket (Item 51, Appendix C)
Socket Set, Socket Wrench (Item 34, Appendix C)
Wrench, Torque, 0-200 lb-in. (Item 59, Appendix C)
Adapter, Socket Wrench (Item 2, Appendix B)
Heater, Gun Type, Electric (Item 24, Appendix B)
Crowfoot Attachment, Socket Wrench (Item 8, Appendix B)

Materials/Parts

Dispenser, Pressure Sensitive Adhesive Tape (Item 20, Appendix D)
Adhesive (Item 8, Appendix D)
Adhesive (Item 9, Appendix D)
Bolt, Machine (3) (Item 2, Appendix G)
Gasket (Item 39, Appendix G)
Splice, Conductor (Item 261, Appendix G)
Tape, Insulation, Electrical (Item 68, Appendix D)
Insulation, Sleeving, Electrical (Item 28.1, Appendix D)

Personnel Required

(2)

WARNING

Wear appropriate eye protection when working under vehicle due to the possibility of falling debris. Failure to comply may result in injury to personnel.

a. Removal.

NOTE

Tag wires and connection points prior to disconnecting.

- (1) Remove adhesive, nut (1), terminal lugs TL55 (2) and TL12 (3) from solenoid terminal (4).
- (2) Position nut (1) on solenoid terminal (4).
- (3) Remove adhesive, nut (5), and terminal lug TL26 (6) from solenoid terminal (7).
- (4) Position nut (5) on solenoid terminal (7).

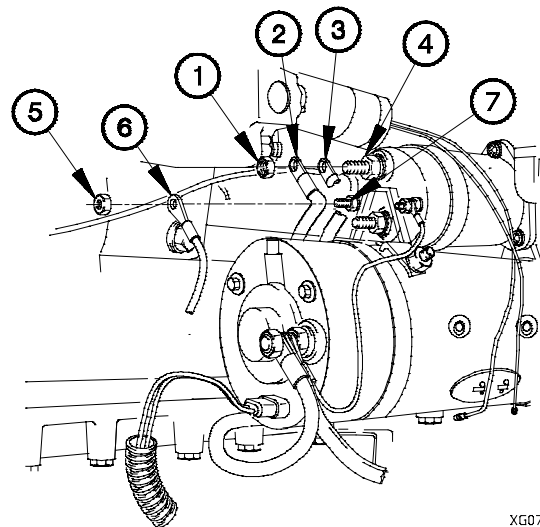

XG07B01B

7-7. STARTING MOTOR REPLACEMENT (CONT)

- (5) Remove adhesive, nut (8), terminal lugs TL25 (9), TL46 (10), ground strap (11), and terminal lug TL53 (12) from starting motor terminal (13).
- (6) Position nut (8) on starting motor terminal (13).

NOTE

Perform step (7) on vehicles that have not had connector P81 removed.

- (7) Disconnect connector P81 (14) from starting motor connector (15).

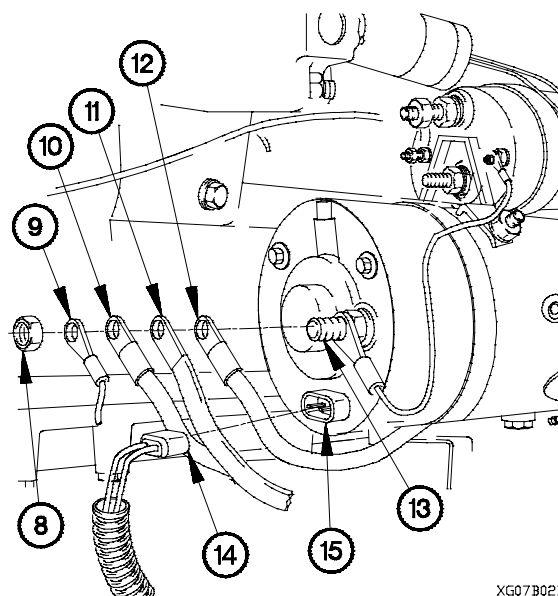

XG07B02B

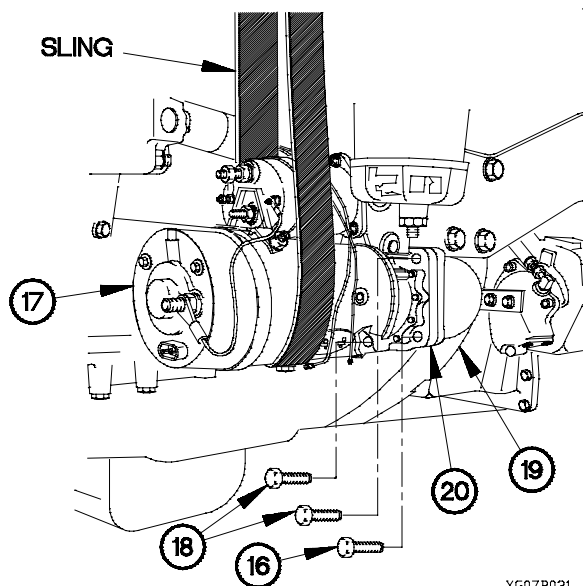

XG07B031

- (8) Remove screw (16) from starting motor (17). Discard screw.

WARNING

Starting motor weighs approximately 60 lbs (27 kgs). Attach a suitable lifting device prior to removal. Failure to comply may result in injury to personnel or damage to equipment.

NOTE

Step (9) requires the aid of an assistant.

- (9) Remove two screws (18) and starting motor (17) from flywheel housing (19). Discard screws.
- (10) Remove gasket (20) from starting motor (17). Discard gasket.

b. Installation.

- (1) Deleted.
- (2) Deleted.
- (3) Deleted.

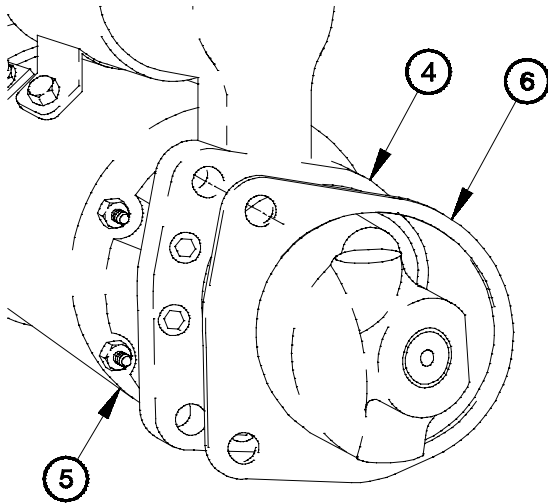

XG07C021

WARNING

Adhesives, solvents, and sealing compounds can burn easily, can give off harmful vapors, and are harmful to skin and clothing. Keep away from open fire and use in a well-ventilated area. If adhesive, solvent, or sealing compound gets on skin or clothing, wash immediately with soap and water. Failure to comply may result in injury to personnel.

- (4) Apply a bead of adhesive around flange (4) of starting motor (5).
- (5) Install gasket (6) on starting motor (5).
- (6) Apply a bead of adhesive around gasket (6).

7-7. STARTING MOTOR REPLACEMENT (CONT)

WARNING

Starting motor weighs approximately 60 lbs (27 kgs). Attach a suitable lifting device prior to installation. Failure to comply may result in injury to personnel or damage to equipment.

NOTE

Step (7) requires the aid of an assistant.

- (7) Position starting motor (5) in flywheel housing (7) with two screws (8).
- (8) Position screw (9) in starting motor (5).
- (9) Tighten two screws (8) and screw (9) to 47 lb-ft (64 N-m).

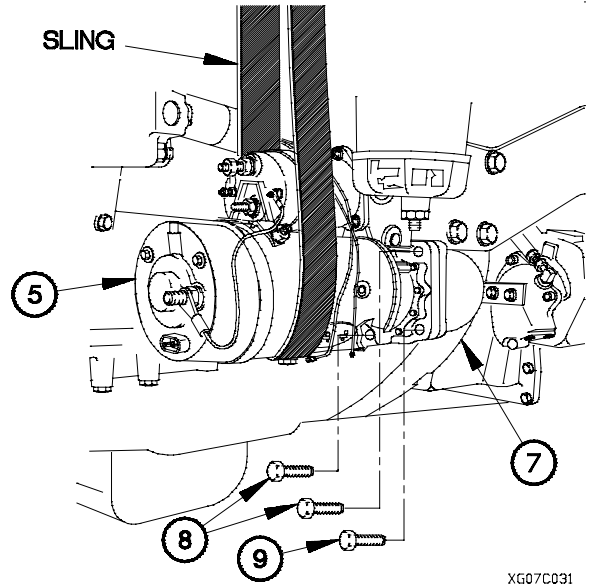

NOTE

Perform step (10) through (21) on vehicles that have not had connector P81 removed.

- (10) Cut connector P81 (10) from start and charging cable assembly (11).
- (11) Remove band marker (12) from start and charging cable assembly (11).

NOTE

Remove electrical tape as required.

- (12) Remove convoluted tubing (13) from two wires (14 and 15).
- (13) Remove insulation sleeving (16) from two wires (14 and 15).

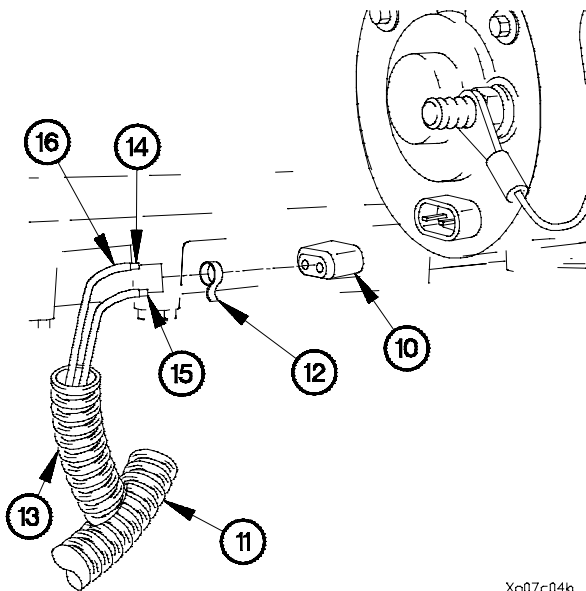

NOTE

Measure wires from body of start and charging cable assembly.

- (14) Cut wire (14) to 3 in. (7.6 cm) in length.
- (15) Cut wire (15) to 4 in. (10.2 cm) in length.
- (16) Remove 0.38 in. (1 cm) of insulation from two wires (14 and 15).
- (17) Cut insulation sleeving (17) 1.5 in. (3.8 cm).
- (18) Position insulation sleeving (17) on wire (15).
- (19) Install conductor splice (18) on two wires (14 and 15).
- (20) Install insulation sleeving (17) on conductor splice (18).

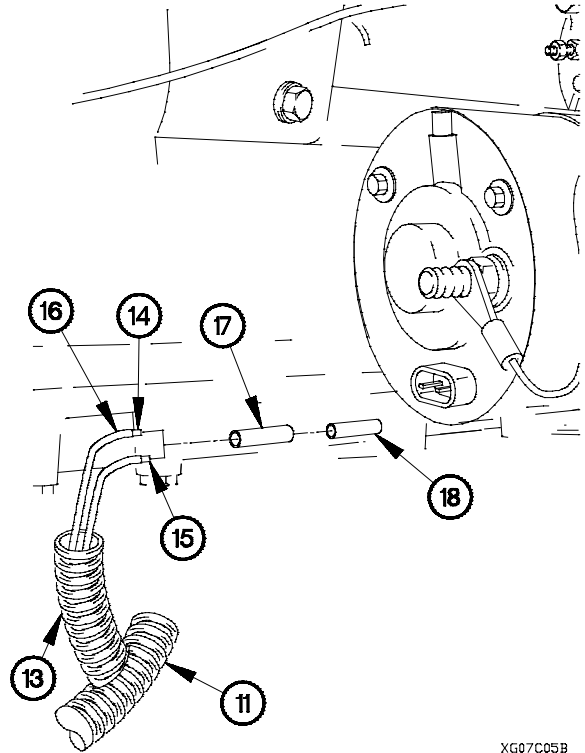

NOTE

Install electrical tape as required.

- (21) Install convoluted tubing (13) on two wires (14 and 15).

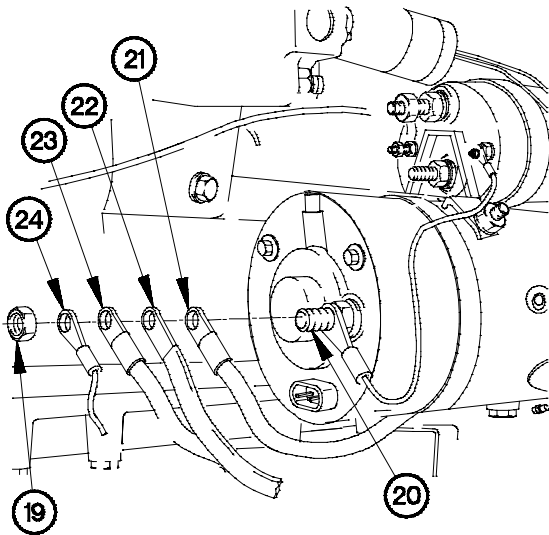

- (22) Deleted.
- (23) Remove nut (19) from starting motor terminal (20).
- (24) Position terminal lug TL53 (21), ground strap (22), terminal lugs TL46 (23), and TL25 (24) on starting motor terminal (20) with nut (19).
- (25) Tighten nut (19) to 33-37 lb-ft (45-50 N·m).

WARNING

Adhesives, solvents, and sealing compounds can burn easily, can give off harmful vapors, and are harmful to skin and clothing. Keep away from open fire and use in a well-ventilated area. If adhesive, solvent, or sealing compound gets on skin or clothing, wash immediately with soap and water. Failure to comply may result in injury to personnel.

- (26) Apply adhesive on terminal lug TL53 (21), ground strap (22), terminal lugs TL46 (23), TL25 (24), nut (19), and starting motor terminal (20).

7-7. STARTING MOTOR REPLACEMENT (CONT)

- (27) Remove nut (25) from solenoid terminal (26).
- (28) Position terminal lug TL26 (27) on solenoid terminal (26) with nut (25).
- (29) Tighten nut (25) to 31 lb-in. (4 N·m).
- (30) Remove nut (28) from solenoid terminal (29).
- (31) Position terminal lugs TL12 (30) and TL55 (31) on solenoid terminal (29) with nut (28).
- (32) Tighten nut (28) to 30 lb-ft (41 N·m).

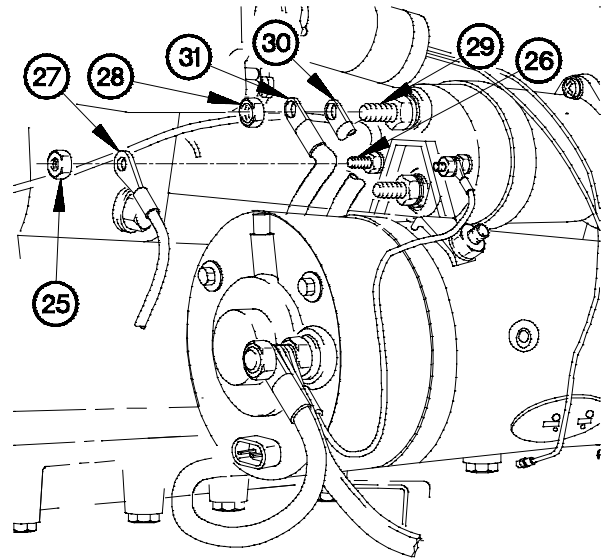

XG07C07B

WARNING

Adhesives, solvents, and sealing compounds can burn easily, can give off harmful vapors, and are harmful to skin and clothing. Keep away from open fire and use in a well-ventilated area. If adhesive, solvent, or sealing compound gets on skin or clothing, wash immediately with soap and water. Failure to comply may result in injury to personnel.

- (33) Apply adhesive on terminal lug TL26 (27), solenoid terminal (26), and nut (25).
- (34) Apply adhesive on terminal lugs TL12 (30), TL55 (31), solenoid terminal (29), and nut (28).

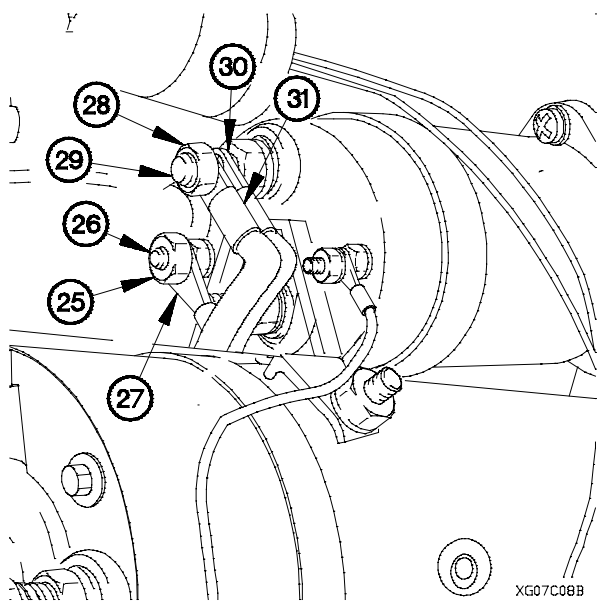

XG07C08B

c. Follow-On Maintenance.

- (1) Lower cab (TM 9-2320-366-10-1).
- (2) Connect batteries (para 7-57).
- (3) Start engine (TM 9-2320-366-10-1).
- (4) Shut down engine (TM 9-2320-366-10-1).

End of Task.

7-8. AUXILIARY PANEL REPLACEMENT

This task covers:

- a. Removal
- b. Installation
- c. Follow-On Maintenance

INITIAL SETUP

Equipment Conditions

Batteries disconnected (para 7-57).

Tools and Special Tools

Tool Kit, Genl Mech (Item 46, Appendix C)
 Wrench, Torque, 0-75 lb-in. (Item 90, Appendix B)
 Wrench, Torque, 0-200 lb-in. (Item 59, Appendix C)
 Socket Set, Socket Wrench (Item 34, Appendix C)

Materials/Parts

Dispenser, Pressure Sensitive Adhesive Tape (Item 20, Appendix D)
 Decal (Item 11, Appendix G)
 Nut, Self-Locking (2) (Item 131, Appendix G)

a. Removal.

- (1) Remove six screws (1) from auxiliary panel (2).
- (2) Lift auxiliary panel (2) outward from auxiliary panel housing (3) to gain access.

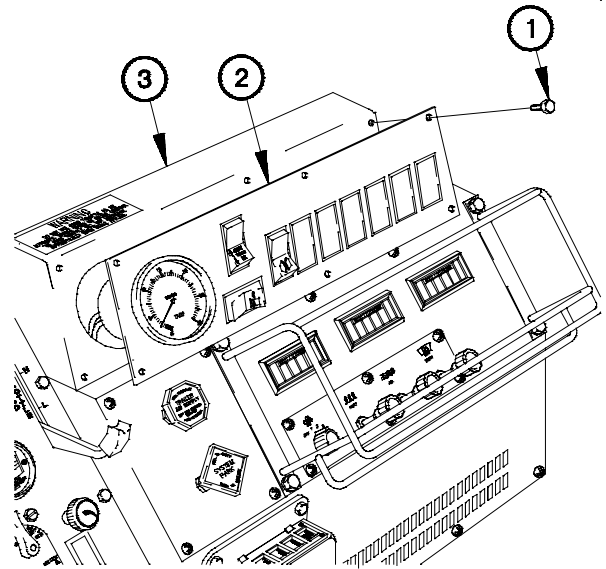

XG08R011

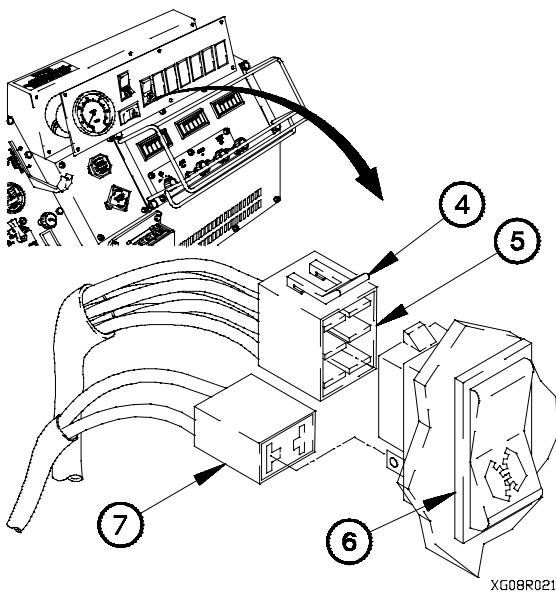

XG08R021

NOTE

- Tag electrical connectors and connection points prior to removal.
 - All rocker switches are removed the same way. PTO switch shown.
- (3) Lift tab (4) on connector P904 (5).
 - (4) Disconnect connector P904 (5) from PTO switch (6).
 - (5) Disconnect connector P904A (7) from PTO switch (6).

- (6) Push in two tabs (8) on PTO switch (6).
- (7) Remove PTO switch (6) from auxiliary panel (2).

NOTE

Auxiliary panel rocker switches will vary according to vehicle model.

- (8) Perform steps (3) through (7) on remaining rocker switches.

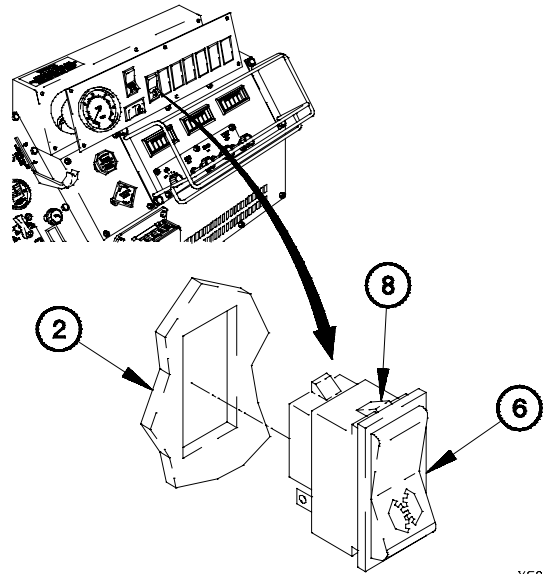

XG08R031

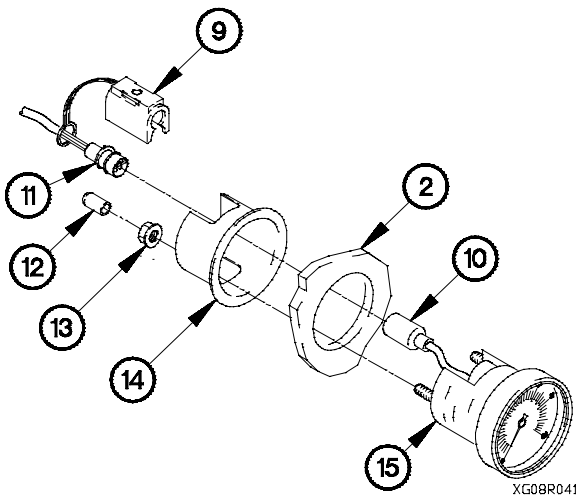

XG08R041

- (9) Disconnect connector clamp (9) from tachometer connector (10).
- (10) Disconnect connector P901 (11) from tachometer connector (10).
- (11) Remove two protective caps (12), self-locking nuts (13), retaining ring (14), and tachometer (15) from auxiliary panel (2). Discard self-locking nuts.
- (12) Remove auxiliary panel (2) from vehicle.

- (13) Remove eight screws (16) from auxiliary panel housing (3).
- (14) Remove auxiliary panel housing (3) from heater assembly (17).
- (15) Remove auxiliary panel cable assembly (18) from auxiliary panel housing (3).

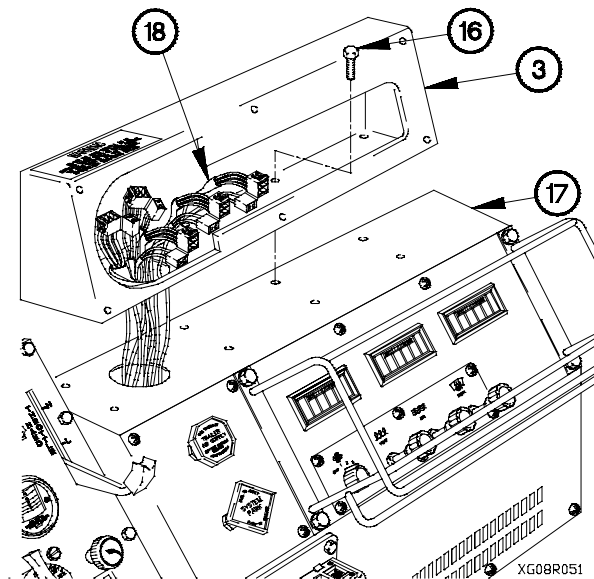

XG08R051

7-8. AUXILIARY PANEL REPLACEMENT (CONT)

b. Installation.

- (1) Install decal (1) on auxiliary panel housing (2).
- (2) Route auxiliary panel cable assembly (3) in auxiliary panel housing (2).
- (3) Position auxiliary panel housing (2) on heater assembly (4) with eight screws (5).
- (4) Tighten eight screws (5) to 35-44 lb-in. (4-5 N-m).

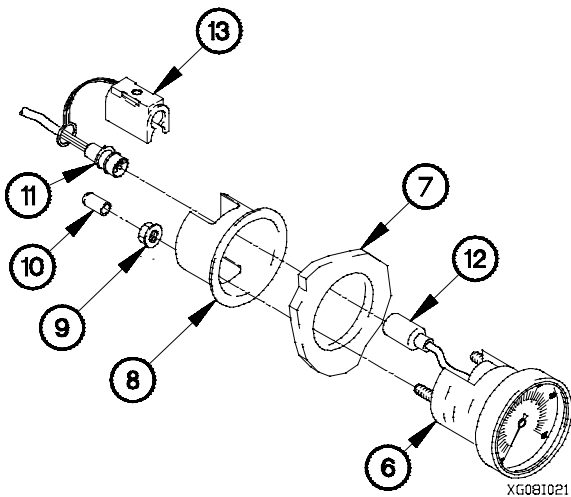
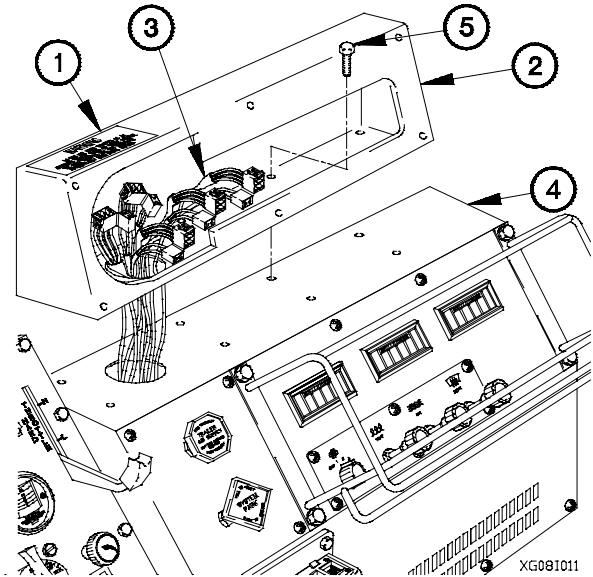

- (5) Position tachometer (6) in auxiliary panel (7) with retaining ring (8) and two self-locking nuts (9).
- (6) Tighten two self-locking nuts (9) to 9 lb-in. (1 N-m).
- (7) Install two protective caps (10) on tachometer (6).
- (8) Connect connector P901 (11) to tachometer connector (12).
- (9) Connect connector clamp (13) on tachometer connector (12).

NOTE

All rocker switches are installed the same way. PTO switch shown.

- (10) Install PTO switch (14) in auxiliary panel (7).
- (11) Connect connector P904A (15) to PTO switch (14).
- (12) Connect connector P904 (16) to PTO switch (14).

NOTE

Auxiliary panel rocker switches will vary according to vehicle model.

- (13) Perform steps (10) through (12) on remaining rocker switches.

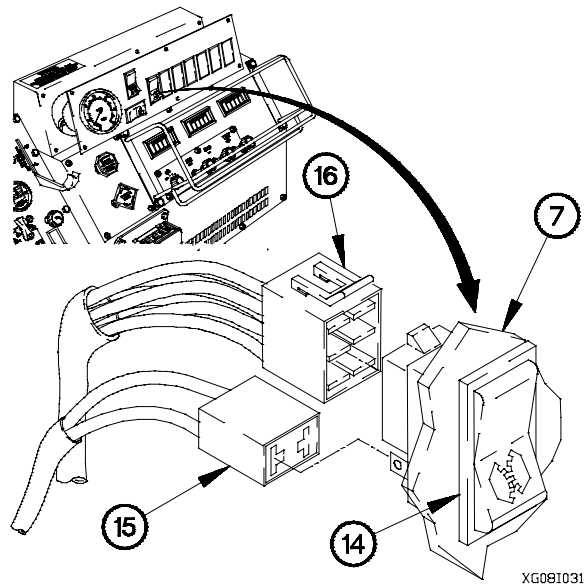

XG08I031

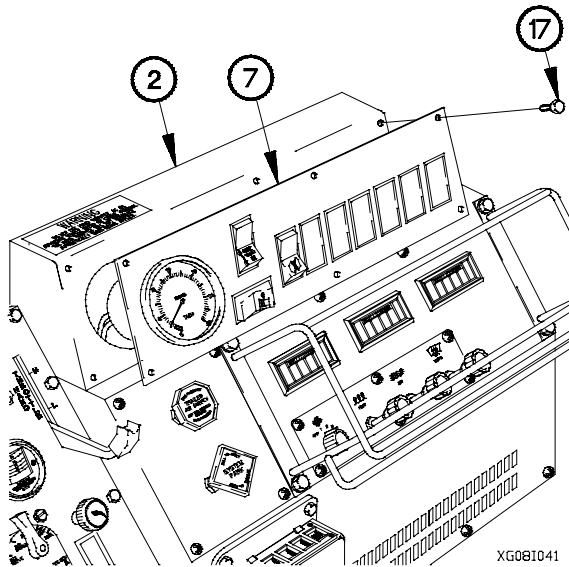

XG08I041

- (14) Position auxiliary panel (7) on auxiliary panel housing (2) with six screws (17).
- (15) Tighten six screws (17) to 18 lb-in. (2 N-m).

c. Follow-On Maintenance.

- (1) Connect batteries (para 7-57).
- (2) Check rocker switches and tachometer operation (TM 9-2320-366-10-1).

End of Task.

7-9. CIRCUIT BREAKER, DIODE, AND RELAY REPLACEMENT

This task covers:

- a. Removal
- b. Installation
- c. Follow-On Maintenance

INITIAL SETUP

Equipment Conditions

- Batteries disconnected (para 7-57).
- PDP cover removed (para 16-2).

NOTE

All circuit breakers, diodes, and relays are replaced the same way. Circuit breaker replacement shown.

a. Removal.

- (1) Locate diode, relay, or circuit breaker to be replaced.

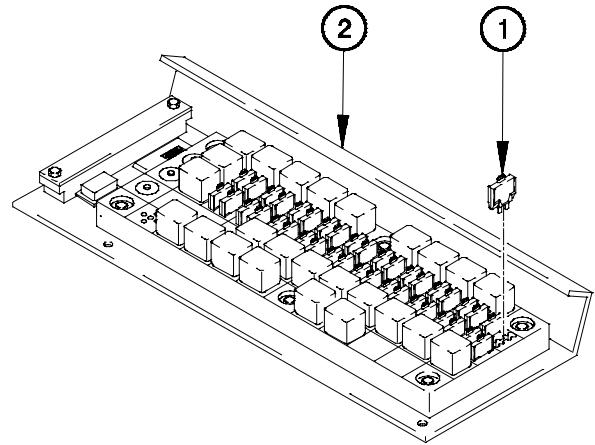

NOTE

Refer to Figure 7-1. Power Distribution Panel (PDP) Circuit Breakers, Diodes, and Relays, Table 7-1. Power Distribution Panel (PDP) Relays, and Table 7-1.1 Power Distribution Panel (PDP) Circuit Breakers for details.

- (2) Remove circuit breaker (1) from PDP (2).

xa09X011.dwg

Figure 7-1. Power Distribution Panel (PDP) Circuit Breakers, Diodes, and Relays

	D3	K12	K15	K9	K2		K32	K13	K19	K24	
	D1										
	D2										
	Storage	K25	K29	K6	K11	K26	K1	K10	K8	K7	
	K20	K52	K53	K28	K27		K30	K31	K34	K37	

XG09A02B

Table 7-1. Power Distribution Panel (PDP) Relays

Relay	VDC	Throw	Function	Remarks
K1	24 VDC	SPST	Starter Relay	
K2	12 VDC	SPST	Control Power Relay	
K6	12 VDC	SPST	Stop Light Relay	
K7	12 VDC	SPST	Headlight Relay	
K8	12 VDC	SPDT	Headlight LO/HI-Beam Relay	
K9	12 VDC	SPDT	Hazard Flasher Blackout Override Relay	
K10	12 VDC	SPDT	Stop/Hazard Flasher Relay	
K11	24 VDC	SPDT	Alternator Excitation Relay	
K12	12 VDC	SPST	Worklights Relay	M1088/M1089
K13	12 VDC	SPST	Rotating Beacon Relay	
K15	24 VDC	SPDT	Auxiliary Oil Cooler Relay	
K19	24 VDC	SPDT	Start Inhibit Relay	
K20	12 VDC	SPST	Marker Lights Relay	
K24	24 VDC	SPDT	Cranking Lock-Out Relay	
K25			Empty	WTEC II
K25	24 VDC	SPST	Reverse Warning Relay	WTEC III
K26	24 VDC	SPST	Neutral Start Relay	WTEC III
K26			Empty	WTEC II
K27	12 VDC	SPST	Blackout Stoplight Relay	
K28	12 VDC	SPST	Trailer Rear Marker and Taillight Relay	
K29	12 VDC	SPST	Trailer Blackout Marker Relay	
K30	12 VDC	SPST	24 VDC Intervehicular Left Rear Composite Lamp Relay	
K31	12 VDC	SPST	24 VDC Intervehicular Right Rear Composite Lamp Relay	
K32	24 VDC	SPST	Horn Relay	
K34			Empty	WTEC II
K34	24 VDC	SPDT	Inter-Axle Relay	WTEC III
K37			Empty	WTEC II
K37	24 VDC	SPST	PTO Relay	WTEC III
K52	12 VDC	SPDT	CTIS Overspeed Indication Relay	
K53	24 VDC	SPDT	Radio Power	

7-9. CIRCUIT BREAKER, DIODE, AND RELAY REPLACEMENT (CONT)

Table 7-1.1 Power Distribution Panel (PDP) Circuit Breakers

CB	Amp	Function	Reset	Remarks
CB20	25 AMP	Cab Radio	Manual	
CB21	15 AMP	Air Dryer, Dump Up Indicator Light, Dump Up Indicator Switch, Frequency Divider, Interaxle Differential Solenoid, and Starter Pushbutton Switch	Manual	
CB22	10 AMP	Engine Fan Off Switch, Ether Start Solenoid, Ether Start Switch, Ether Sensor, Fan Solenoid, and Water Temperature Switch (fan)	Manual	
CB23	15 AMP	Personnel Heater	Manual	
CB30	10 AMP	Chemical Alarm, Chemical Detector, and Chemical Detector Indicator Light	Manual	
CB35	15 AMP	WTEC II TEPSS and WTEC II VIM	Manual	WTEC II
CB35	15 AMP	Empty	Manual	WTEC III
CB36	20 AMP	Horn	Manual	
CB37	20 AMP	Windshield Wiper ECU and Wiper Motor	Manual	
CB38	20 AMP	Rotating Warning Light(s)	Manual	
CB39	10 AMP	24 VDC Intervehicular Blackout Stoplights	Manual	
CB40	10 AMP	CTIS, CTIS Air Pressure Switch, and CTIS Overspeed Indicator Light	Manual	
CB41	15 AMP	24 VDC Intervehicular Clearance and Rear Lights	Manual	
CB42	10 AMP	24 VDC Intervehicular Blackout Clearance, Left Blackout Marker, and Right Blackout Marker Lights	Manual	
CB43	15 AMP	24 VDC Intervehicular Left Turn Light and Stoplight	Manual	WTEC II
CB43	10 AMP	WTEC III Transmission ECU Power	Manual	WTEC III
CB44	15 AMP	24 VDC Intervehicular Right Turn Light and Stoplight	Manual	WTEC II
CB44	15 AMP	24 VDC Intervehicular Right and Left Turn Lights and Stoplights	Manual	WTEC III
CB45	15 AMP	Not Used	Manual	
CB48	20 AMP	Not Used	Manual	
CB49	15 AMP	Fuel/Water Separator, PTO Solenoid, PTO Switch, Winch In Solenoid, Winch In/Out Switch, Winch Out Solenoid, and Winch Switch	Manual	
CB50	15 AMP	Dump Down Solenoid, Dump Up Solenoid, Dump Up/Down Switch, Tailgate Release Switch, Tailgate Release Solenoid, Wrecker Control Panel, and Wrecker Remote Control	Manual	M1090/M1094
CB53	15 AMP	Material Handling Crane	Manual	

Table 7-1.1 Power Distribution Panel (PDP) Circuit Breakers (CONT)

CB	Amp	Function	Reset	Remarks
CB54	8 AMP	Blackout Drive Light	Manual	
CB61		Empty		
CB62		Empty		
CB63		Empty		
CB64		Empty		
CB65	8 AMP	Front Right and Left Parking Lights	Manual	
CB66	8 AMP	Front Left, Front Right, Rear LH, and Rear RH Blackout Marker Lights and WTEC II/WTEC III TPSS Dimmer Module	Manual	
CB67	25 AMP	12 VDC Intervehicular Marker Light and All Marker Lights	Manual	
CB68	25 AMP	Auxiliary Oil Cooler Fan Motors	Manual	M1088/M1089
CB68	20 AMP	Auxiliary Oil Cooler Fan Motors	Manual	All models except M1088/M1089
CB70	20 AMP	Circuit Breakers CB54, CB65, CB66, CB74, and CB76, Dimmer Module, Instrument and Auxiliary Panel Rocker Switch Lights, Instrument and Auxiliary Panel Gage Lights, Main Light Switch, Master Power Switch, Personnel Heater Lights, Headlight HI/LO Switch, and Rotating Warning Light Switch	Manual	
CB71	15 AMP	Hazard Warning Switch, Turn Signal Flasher, and Worklight Switch	Manual	
CB72	15 AMP	Worklights, Blackout Override Switch	Manual	
CB73	8 AMP	Backup Light	Manual	
CB74	10 AMP	Turn Signal Flasher ECU	Manual	
CB76	15 AMP	12 VDC Intervehicular Left and Right Turn Signals, and Stoplight, 24 VDC Intervehicular Auxiliary, Front Left and Right Turn Signals, Hazard Warning Switch, Left and Right Blackout Stoplights, Left and Right Turn Signal Indicators, Rear Right and Left Turn Signals, Stoplight Switches (A) and (B), and Tractor Stoplight Switch	Manual	

7-9. CIRCUIT BREAKER, DIODE, AND RELAY REPLACEMENT (CONT)

Table 7-1.1 Power Distribution Panel (PDP) Circuit Breakers (CONT)

CB	Amp	Function	Reset	Remarks
CB77	10 AMP	Instrument and Auxiliary Panel Gages, Audible Alarm, Emergency Brake Indicator Light, Engine Fan Off Indicator, Engine Fan Off Switch, Engine Oil Pressure Switch, Low Engine Oil Pressure Sensor, Engine Oil Pressure Switch Indicator Light, Front and Rear Brake Air Indicator Lights, Front and Rear Brake Air Indicator Light Switches, Front and Rear Brake Air Pressure Transmitters, Magnetic Pickup, Master Stop Indicator Light, Parking Brake Indicator Light, Parking Brake Switch, PTO Indicator Light, PTO Pressure Switch, Transmission Temperature Indicator Light, Troop Transport Alarm Switch, Water Temperature Indicator Light, Water Temperature Sensor, Water Temperature Switch and Fuel Level Sensor	Manual	
CB78	15 AMP	Left and Right Headlights	Auto	
CB79	15 AMP	WTEC II 10 AMP Fuse TEPSS, Fuel Solenoid, M1089 Remote Engine Kill Switch, and Start Inhibit Pushbutton Switch	Manual	WTEC II
CB79	15 AMP	WTEC III Transmission ECU Power, Fuel Solenoid, M1089 Remote Engine Kill Switch, and Start Inhibit Pushbutton Switch	Manual	WTEC III
CB80	25 AMP	12 VDC Intervehicular Taillight, Left and Right Taillights	Manual	

b. Installation.

NOTE

Refer to Figure 7-1. Power Distribution Panel (PDP) Circuit Breakers, Diodes, and Relays, Table 7-1. Power Distribution Panel (PDP) Relays, and Table 7-1.1 Power Distribution Panel (PDP) Circuit Breakers for details.

Install circuit breaker (1) on PDP (2).

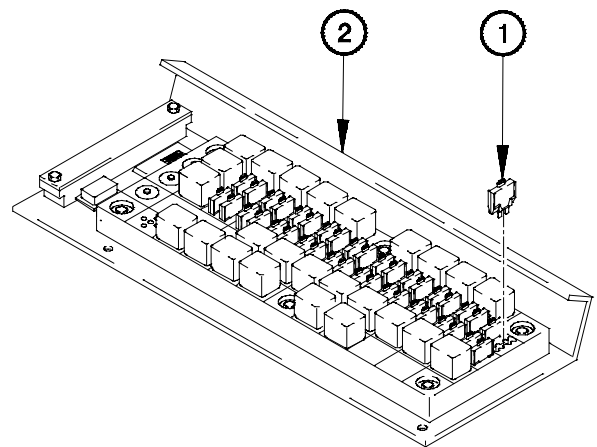

c. Follow-On Maintenance.

- (1) Install PDP cover (para 16-2).
- (2) Connect batteries (para 7-57).

End of Task.

XG09B01B

7-10. WTEC II DASHBOARD CABLE ASSEMBLY REPLACEMENT/REPAIR

This task covers:

- | | |
|----------------|--------------------------|
| a. Removal | d. Installation |
| b. Disassembly | e. Follow-On Maintenance |
| c. Assembly | |

INITIAL SETUP

Equipment Conditions

- Windshield wiper motor removed (para 18-4).
- Personnel heater removed (para 18-9).
- Instrument panel assembly removed (para 7-15).

Tools and Special Tools

- Tool Kit, Auto Fuel (Item 43, Appendix C)
- Tool Kit, Genl Mech (Item 46, Appendix C)
- Wrench, Torque, 0-175 lb-ft (Item 58, Appendix C)
- Wrench, Torque, 0-200 lb-in. (Item 59, Appendix C)
- Socket Set, Socket Wrench (Item 34, Appendix C)

Materials/Parts

- Dispenser, Pressure Sensitive Adhesive Tape (Item 20, Appendix D)
- Ties, Cable, Plastic (Item 69, Appendix D)
- Lockwasher (4) (Item 71, Appendix G)
- Lockwasher (6) (Item 93, Appendix G)
- Lockwasher (2) (Item 84, Appendix G)
- Lockwasher (10) (Item 83, Appendix G)
- Lockwasher (4) (Item 88, Appendix G)

Personnel Required

(2)

a. Removal.

NOTE

- Remove plastic cable ties as required.
- Tag wires and connection points prior to disconnecting.

- (1) Disconnect steering column switch connector J19 (1) from connector P19 (2).
- (2) Disconnect steering column switch connector P18 (3) from connector J18 (4).
- (3) Disconnect connector J118 (5) from connector P118 (6).

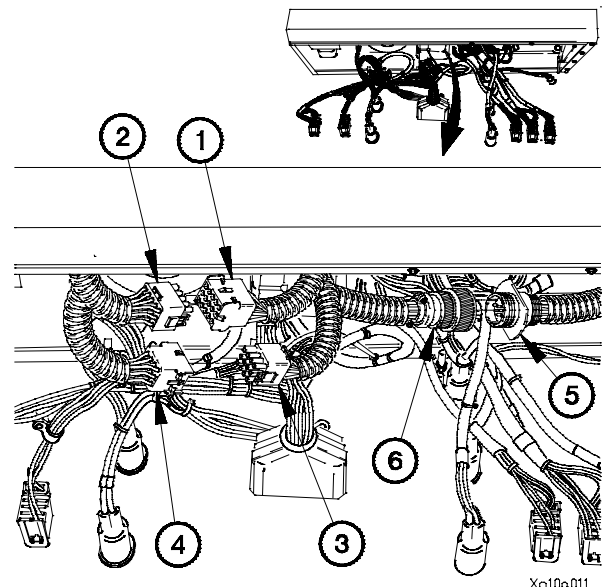

7-10. WTEC II DASHBOARD CABLE ASSEMBLY REPLACEMENT/REPAIR (CONT)

- (4) Disconnect connector J43 (7) from connector P43 (8).
- (5) Disconnect connector J31 (9) from connector P31 (10).

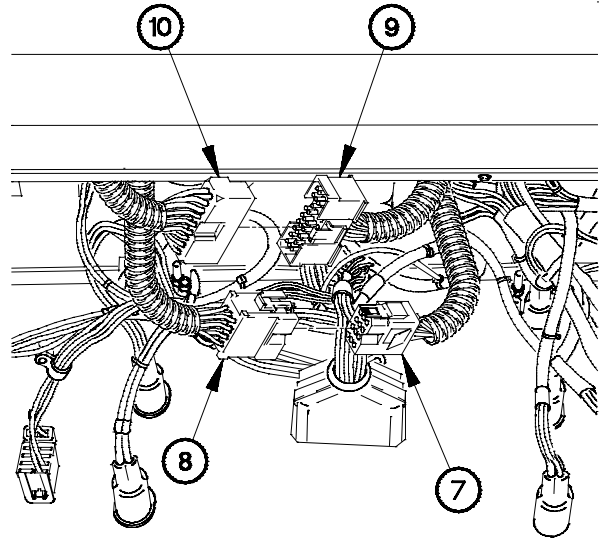

XG10A021

- (6) Remove screw (11), washer (12), and clamp (13) from WTEC II dashboard cable assembly (14).

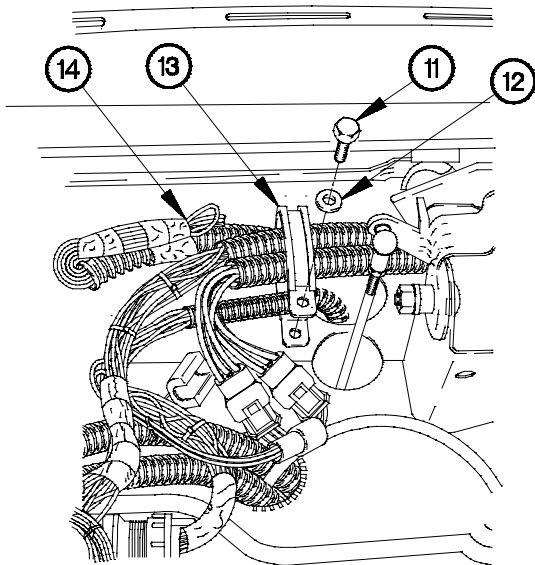

XG10A031

- (7) Disconnect connector PX26 (15) from frequency ECU connector (16).
- (8) Remove two screws (17) and frequency ECU (18) from left side dashboard (19).

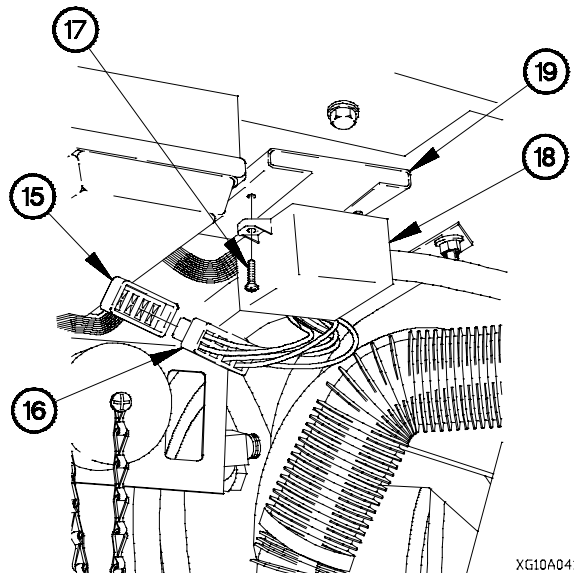

XG10A041

- (9) Remove nut (20), lockwasher (21), and terminal lug TL151 (22) from front brake air pressure transmitter terminal WK (23). Discard lockwasher.
- (10) Remove nut (24), lockwasher (25), and terminal lug TL157 (26) from front brake air pressure transmitter terminal G (27). Discard lockwasher.

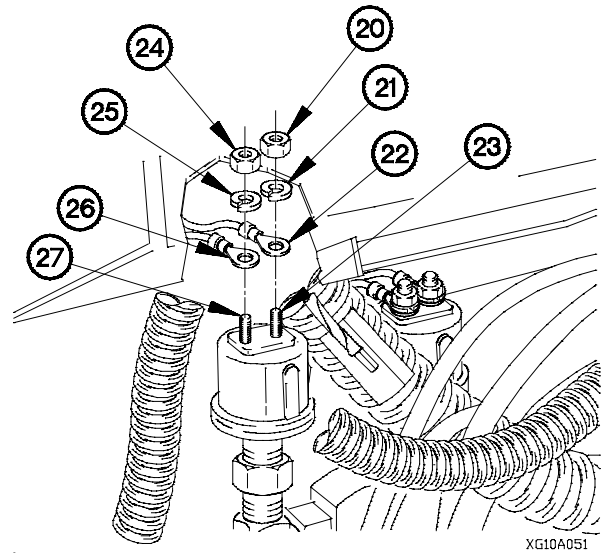

XG10A051

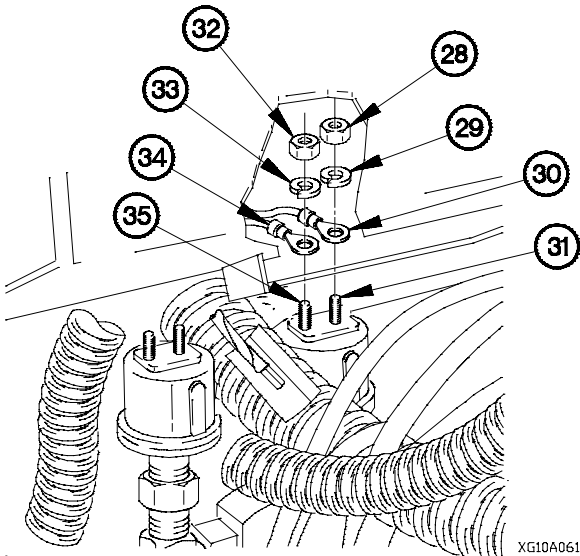

XG10A061

- (11) Remove nut (28), lockwasher (29), and terminal lug TL150 (30) from rear brake air pressure transmitter terminal WK (31). Discard lockwasher.
- (12) Remove nut (32), lockwasher (33), and terminal lug TL156 (34) from rear brake air pressure transmitter terminal G (35). Discard lockwasher.

- (13) Remove two nuts (36), lockwashers (37), and terminal lugs TL153 (38) and TL152 (39) from rear stoplight switch (40). Discard lockwashers.
- (14) Remove two nuts (41), lockwashers (42), and terminal lugs TL154 (43) and TL155 (44) from front stoplight switch (45). Discard lockwashers.

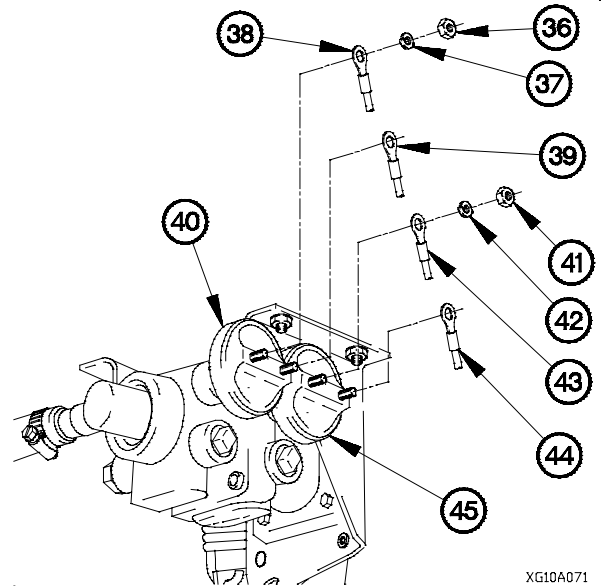

XG10A071

7-10. WTEC II DASHBOARD CABLE ASSEMBLY REPLACEMENT/REPAIR (CONT)

NOTE

Perform steps (15) and (16) on vehicles equipped with auxiliary panel.

- (15) Disconnect connector J912 (46) from connector P912 (47)
- (16) Disconnect connector P913 (48) from connector J913 (49).

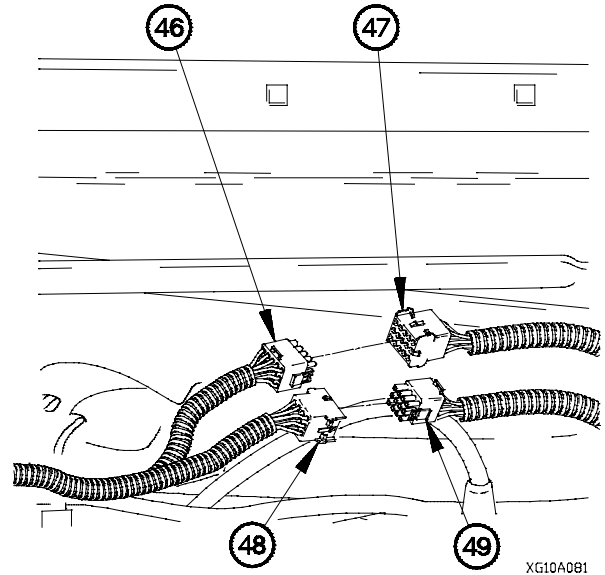

XG10A081

- (17) Remove windshield wiper ECU (50) from PDP (51).

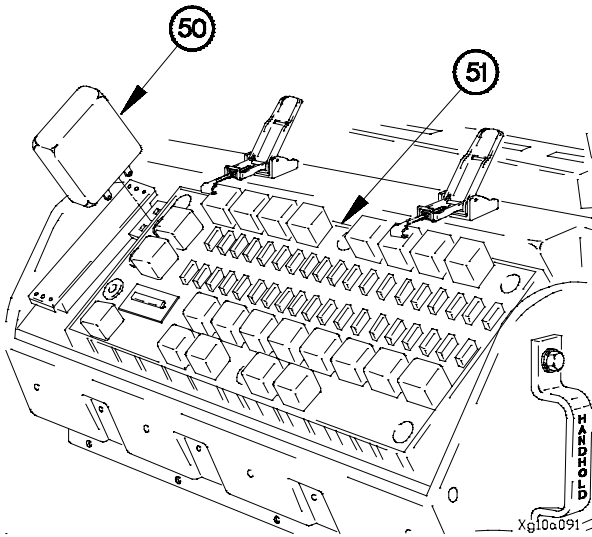

Xg10a091

- (18) Disconnect terminal lugs TL158 (52) and TL159 (53) from start inhibit pushbutton switch (54).
- (19) Remove spring clip (55) from start inhibit pushbutton switch (54).
- (20) Remove start inhibit pushbutton switch (54) from PDP (51).

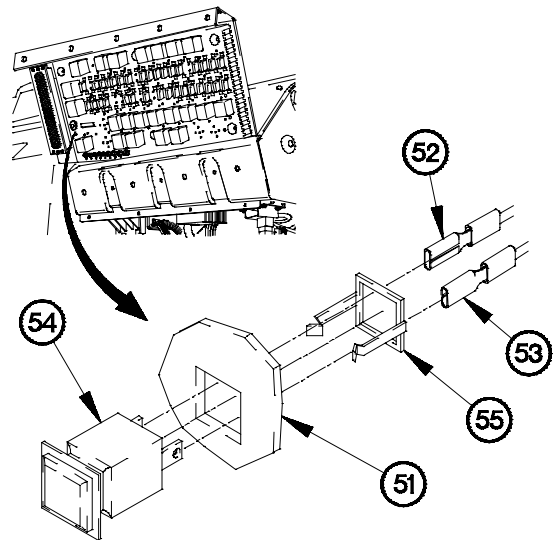

XG10A101

NOTE

Perform step (21) on vehicles not equipped with auxiliary panel.

- (21) Disconnect connector P912A (56) from connector J912 (46).
- (22) Disconnect connector J27 (57) from connector P27 (58).
- (23) Disconnect connector J51 (59) from connector P51 (60).

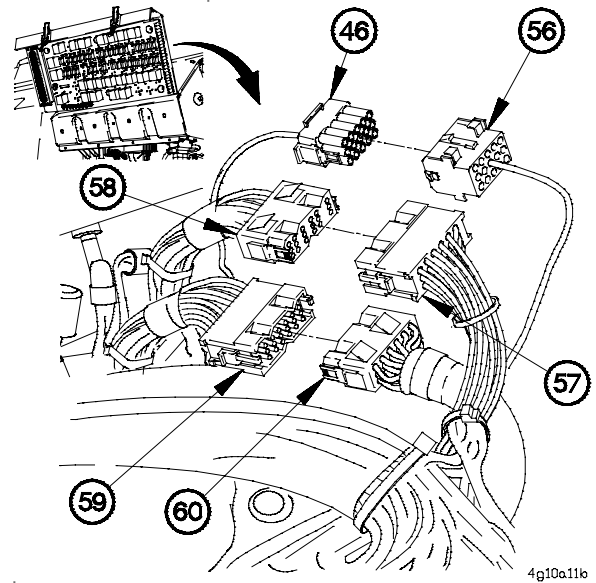

4g10a11b

- (24) Disconnect connector PX34 (61) from fan solenoid connector (62).
- (25) Disconnect connector PX50 (63) from differential solenoid connector (64).
- (26) Disconnect connector J65 (65) from warning light cable connector P65 (66).
- (27) Disconnect connector P99 (67) from chemical alarm kit cable connector J99 (68).

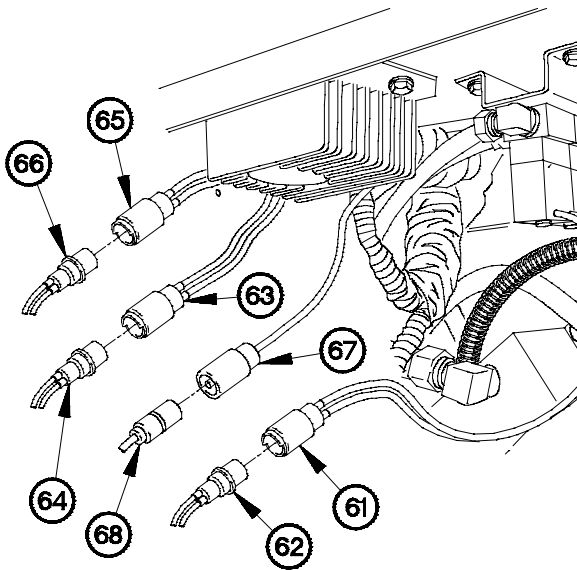

4G10A121

- (28) Disconnect connector PX20 (69) from flasher module (70).
- (29) Disconnect connector P111 (71) from connector J111 (72).

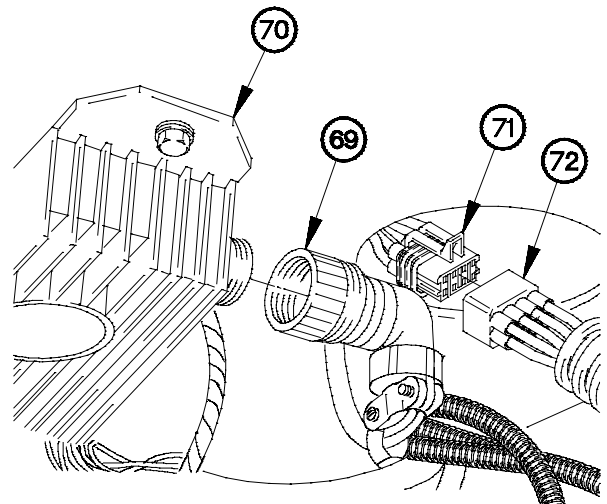

4g10a131

7-10. WTEC II DASHBOARD CABLE ASSEMBLY REPLACEMENT/REPAIR (CONT)

- (30) Loosen captive screw (73) and disconnect connector PX33 (74) from WTEC II VIM (75).

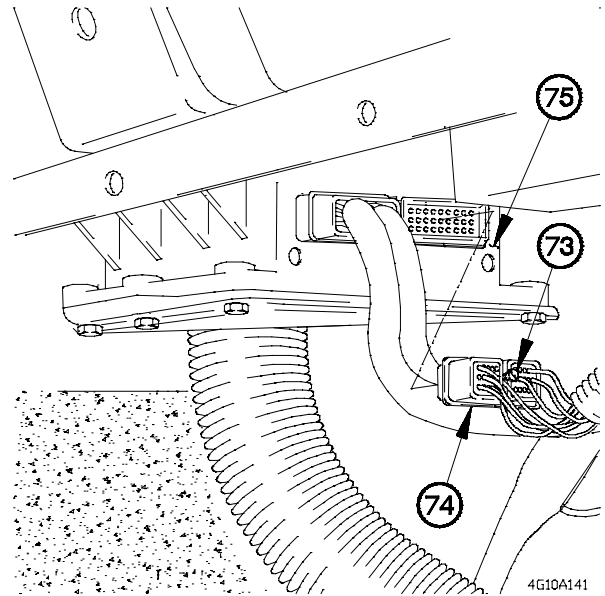

NOTE

Perform step (31) on vehicles equipped with cab radio.

- (31) Disconnect connector J78 (76) from connector P78 (77).

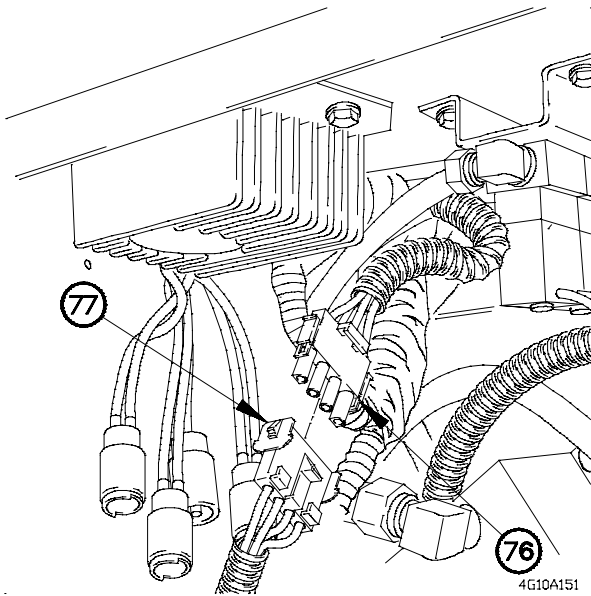

NOTE

Perform step (32) on M1088.

- (32) Remove two nuts (78), lockwashers (79), and terminal lugs TL501 (80) and TL502 (81) from terminal studs (82 and 83). Discard lockwashers.

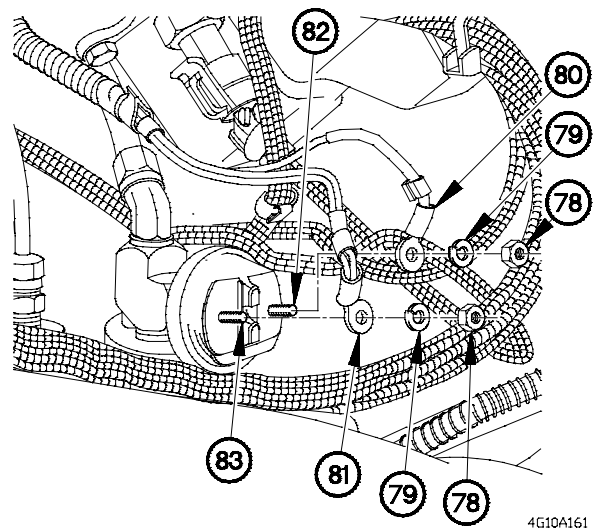

(33) Disconnect WTEC II TEPSS dimmer module (84) from connector J7 (85).

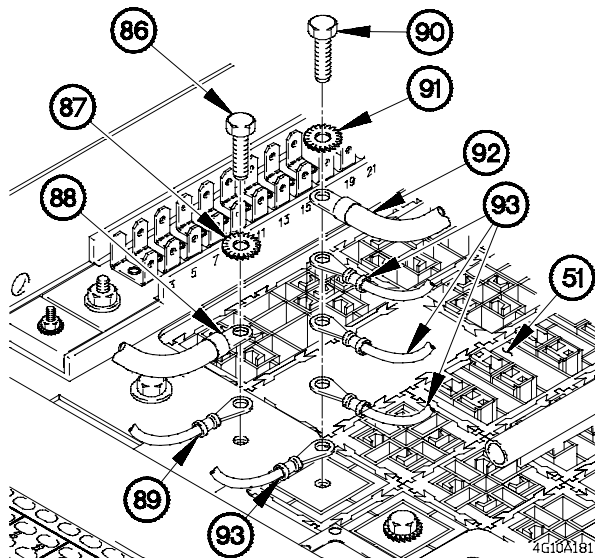
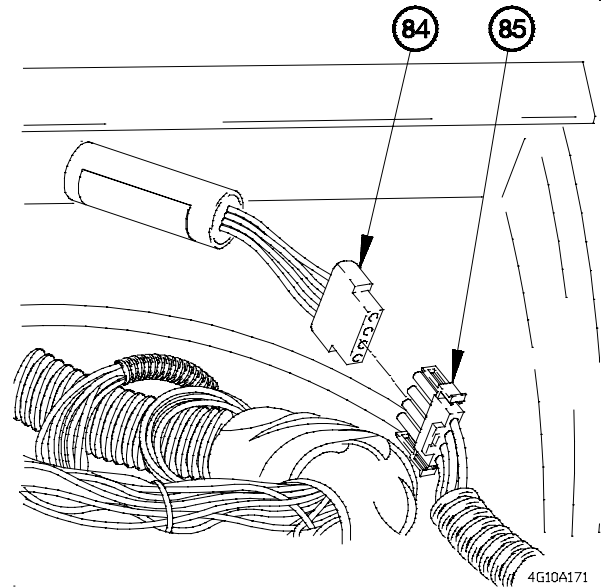

- (34) Remove screw (86), lockwasher (87), terminal lug TL56 (88), and terminal lug (89) from PDP (51).
- (35) Position terminal lug (89) on PDP (51) with lockwasher (87) and screw (86).
- (36) Remove screw (90), lockwasher (91), terminal lug TL41 (92), and four terminal lugs (93) from PDP (51).
- (37) Position four terminal lugs (93) on PDP (51) with lockwasher (91) and screw (90).

7-10. WTEC II DASHBOARD CABLE ASSEMBLY REPLACEMENT/REPAIR (CONT)

- (38) Remove screw (94), lockwasher (95), terminal lug TL42 (96), and four terminal lugs (97) from PDP (51).
- (39) Position four terminal lugs (97) on PDP (51) with lockwasher (95), and screw (94).

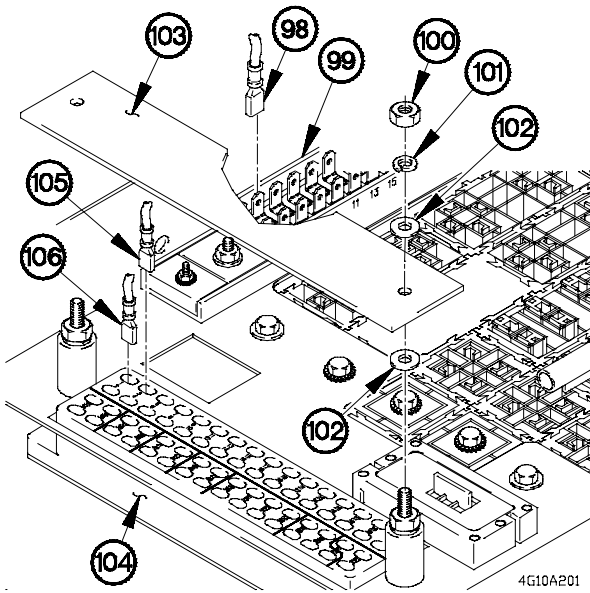
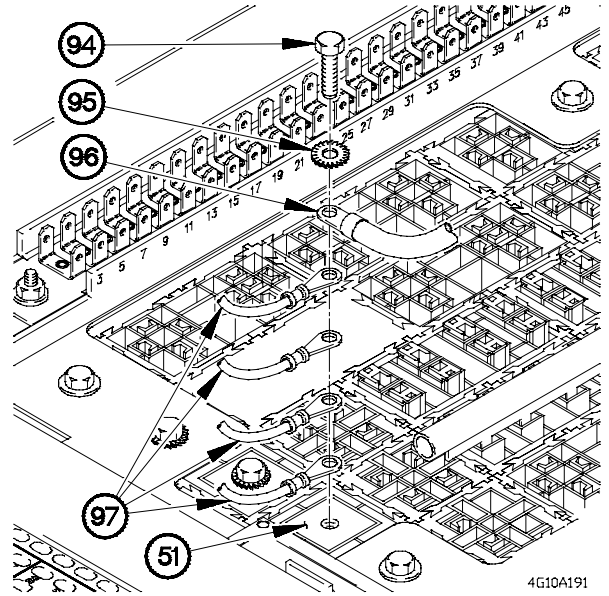

- (40) Remove terminal lug TL86 (98) from terminal board TB2 (99) position 4.
- (41) Remove two nuts (100), lockwashers (101), washers (102), cover (103), and two washers (102) from terminal board TB1 (104).
- (42) Remove terminal lug TL74 (105) from terminal board TB1 (104) position 3.
- (43) Remove terminal lug TL73 (106) from terminal board TB1 (104) position 1.

- (44) Remove terminal lug TL71 (107) from terminal board TB2 (99) position 2.
- (45) Remove terminal lug TL75 (108) from terminal board TB1 (104) position 2.
- (46) Position two washers (102) and cover (103) on terminal board TB1 (104) with two washers (102), lockwashers (101), and nuts (100).
- (47) Remove terminal lug TL87 (109) from terminal board TB2 (99) position 6.
- (48) Remove terminal lug TL14 (110) from terminal board TB2 (99) position 12.

NOTE

Step (49) requires the aid of an assistant.

- (49) Remove WTEC II dashboard cable assembly (14) from dashboard (19).

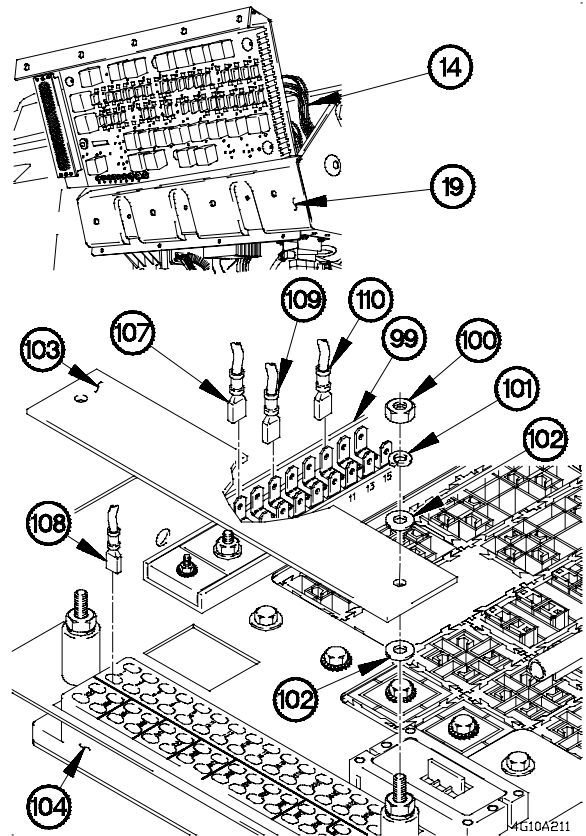

NOTE

- Perform steps (50) and (51) on M1084/M1086/M1088 and M1089.
- Tag relays and circuit breaker prior to removal.

- (50) Remove relay K12 (111) from PDP (51).
- (51) Remove circuit breaker CB72 (112) from PDP (51).
- (52) Remove relay K15 (113) from PDP (51).

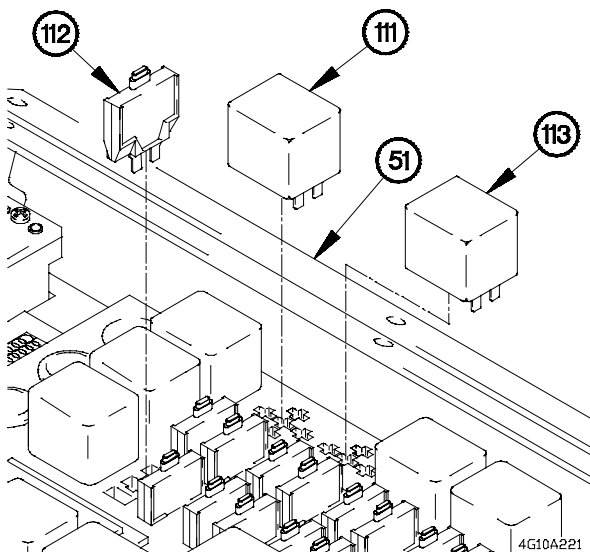

7-10. WTEC II DASHBOARD CABLE ASSEMBLY REPLACEMENT/REPAIR (CONT)

- (53) Remove circuit breaker CB68 (114) from PDP (51).
- (54) Deleted
- (55) Deleted
- (56) Deleted

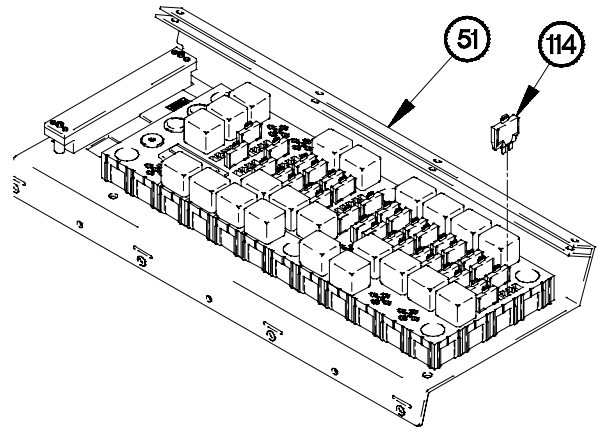

4g10a231

b. Disassembly.

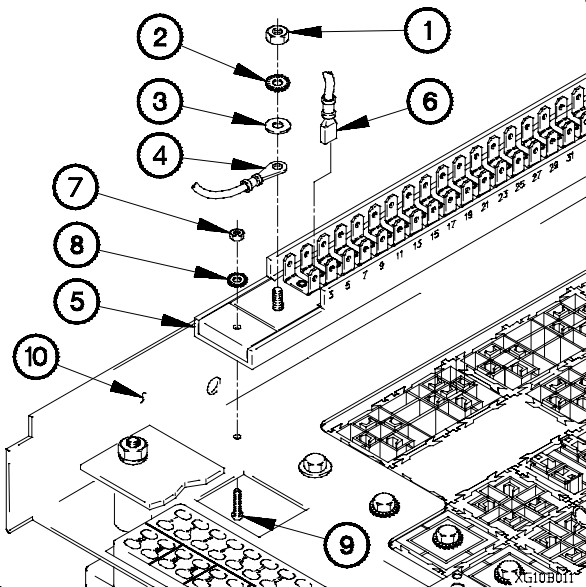

NOTE

Tag wires and connection points prior to removal.

- (1) Remove nut (1), lockwasher (2), washer (3), and wire 1603 (4) from terminal board TB2 (5). Discard lockwasher.
- (2) Remove 42 quick disconnect terminals (6) from terminal board TB2 (5) positions 3, 8, 9, 10, 11, 14, 16, 17, 18, 20, 21, 22, 23, 24, 25, 26, 28, 30, 31, 32, 33, 34, 35, 36, 37, 39, 43, 44, 45, 46, 47, 50, 53, 55, 56, 58, 60, 62, 70, 74, 77, and 79.
- (3) Remove two nuts (7), lockwashers (8), screws (9), and terminal board TB2 (5) from PDP frame (10). Discard lockwashers.

- (4) Remove screw (11), lockwasher (12), and wire 1603 (4) from PDP frame (10). Discard lockwasher.
- (5) Remove two nuts (13), lockwashers (14), washers (15), cover (16), and two washers (15) from terminal board TB1 (17). Discard lockwashers.
- (6) Remove 40 quick disconnect terminals (18) from terminal board TB1 (17) positions 5, 9, 11, 19, 20, 22, 23, 24, 26, 27, 28, 29, 30, 31, 33, 34, 35, 36, 37, 38, 39, 40, 41, 42, 43, 46, 47, 50, 51, 52, 53, 54, 56, 57, 59, 60, 61, 62, 63, and 64.

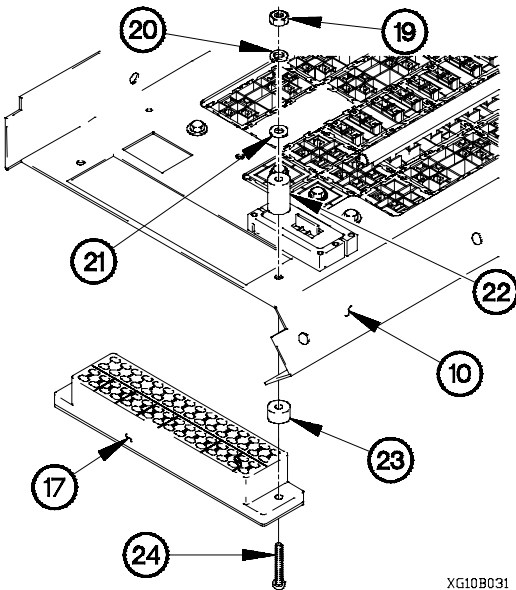
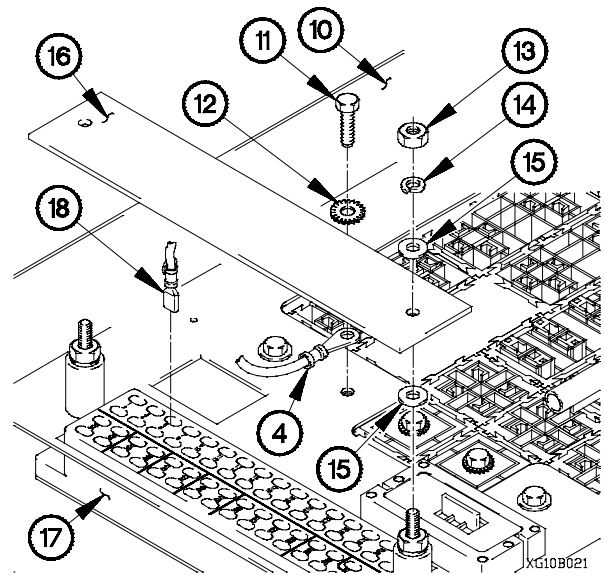

- (7) Remove two nuts (19), lockwashers (20), washers (21), spacers (22), terminal board TB1 (17), two spacers (23), and screws (24) from PDP frame (10). Discard lockwashers.

- (8) Remove six quick disconnect terminals (25) from connector PX21 (26).
- (9) Push in two locking tabs (27) and remove connector PX21 (26) from front of PDP frame (10).

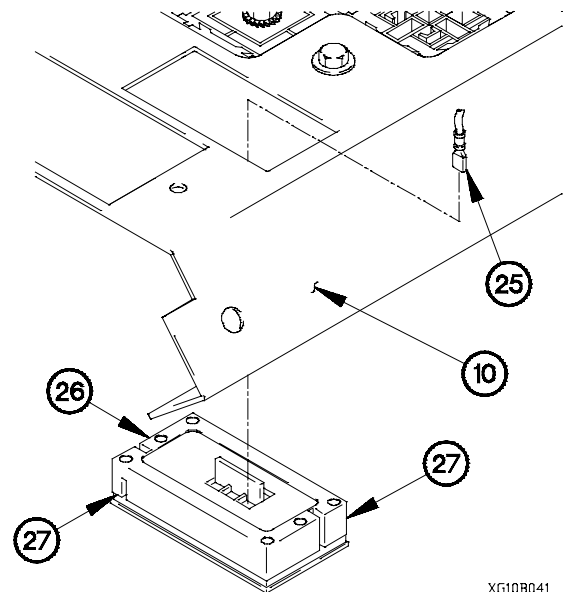

7-10. WTEC II DASHBOARD CABLE ASSEMBLY REPLACEMENT/REPAIR (CONT)

NOTE

Tag terminal lugs and connection points prior to removal.

- (10) Remove screw (28), lockwasher (29), and four terminal lugs (30) from PDP (31). Discard lockwasher.
- (11) Remove screw (32), lockwasher (33), and four terminal lugs (34) from PDP (31). Discard lockwasher.

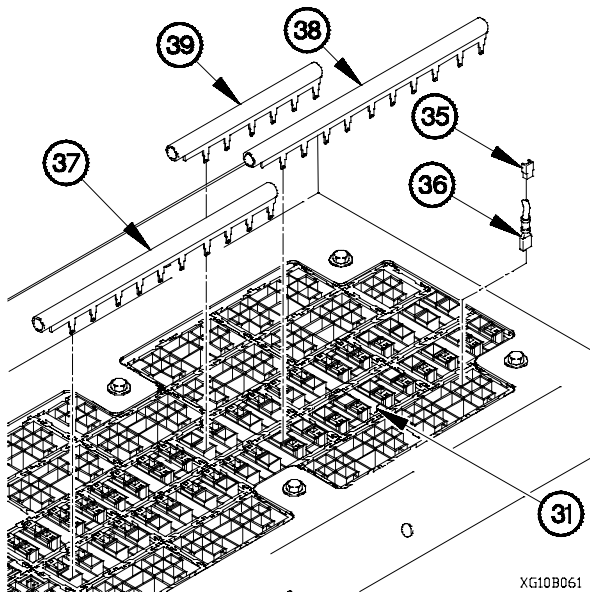
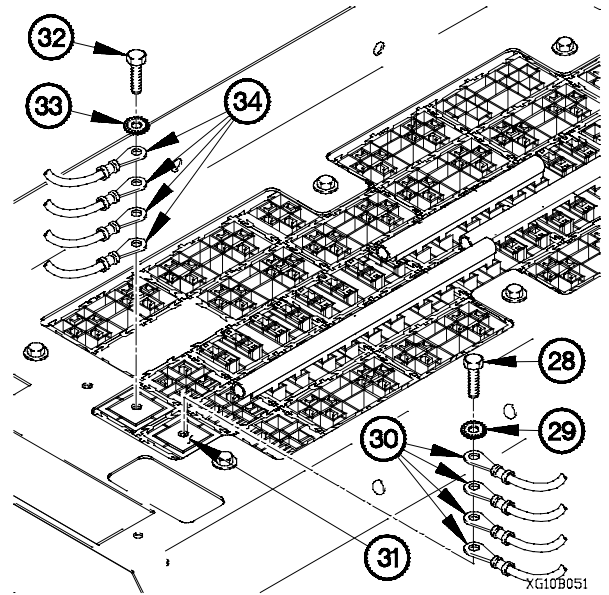

- (12) Remove 94 retaining locks (35) from PDP (31).
- (13) Remove 94 terminals (36) from PDP (31).
- (14) Remove bus bar X1 (37) from PDP (31).
- (15) Remove bus bar X6 (38) from PDP (31).
- (16) Remove bus bar X2 (39) from PDP (31).

(17) Remove 41 retaining locks (40) from PDP (31).

(18) Remove 41 terminals (41) from PDP (31).

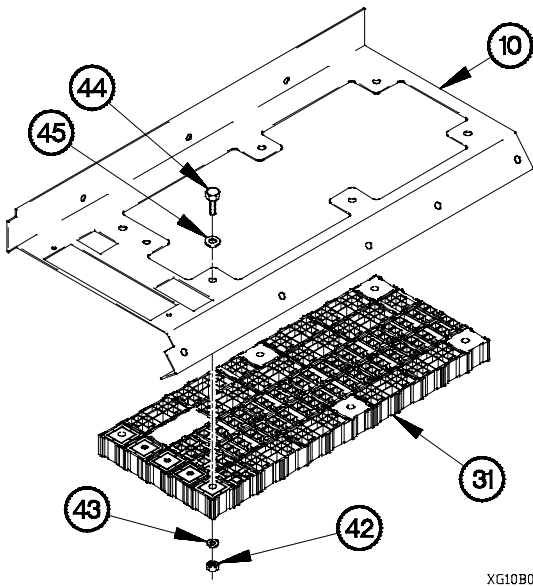
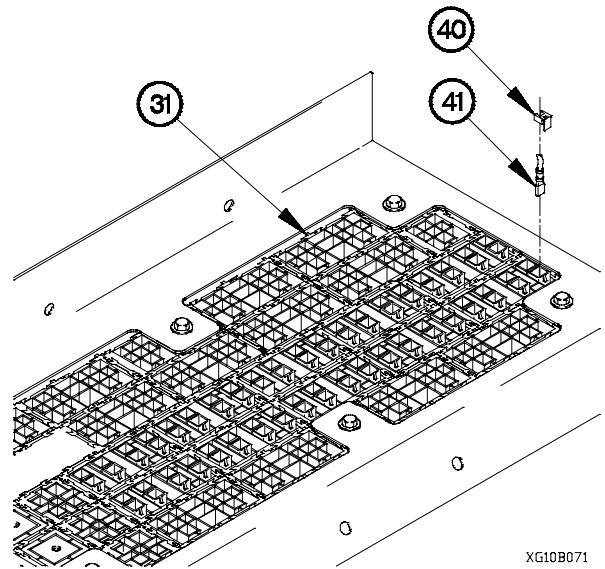

(19) Remove six nuts (42), lockwashers (43), screws (44), washers (45), and PDP (31) from PDP frame (10). Discard lockwashers.

NOTE

Tag diodes, relays, and circuit breakers prior to removal.

(20) Remove three diodes (46) from PDP (31).

(21) Remove 20 relays (47) from PDP (31).

(22) Remove 30 circuit breakers (48) from PDP (31).

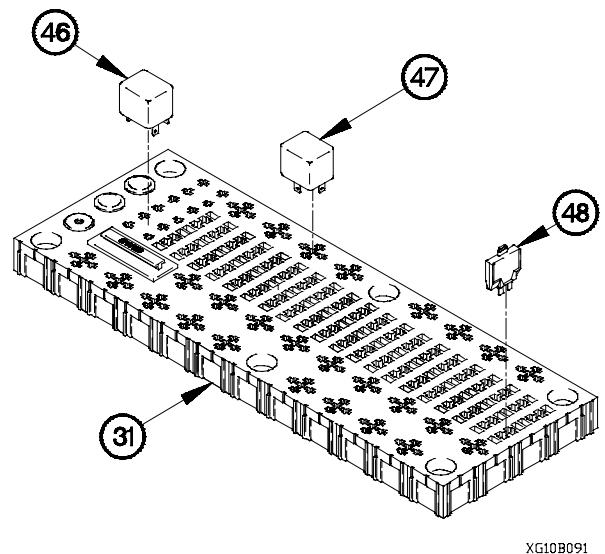

7-10. WTEC II DASHBOARD CABLE ASSEMBLY REPLACEMENT/REPAIR (CONT)

c. Assembly.

- (1) Install 30 circuit breakers (1) on PDP (2).
- (2) Install 20 relays (3) on PDP (2).
- (3) Install three diodes (4) on PDP (2).

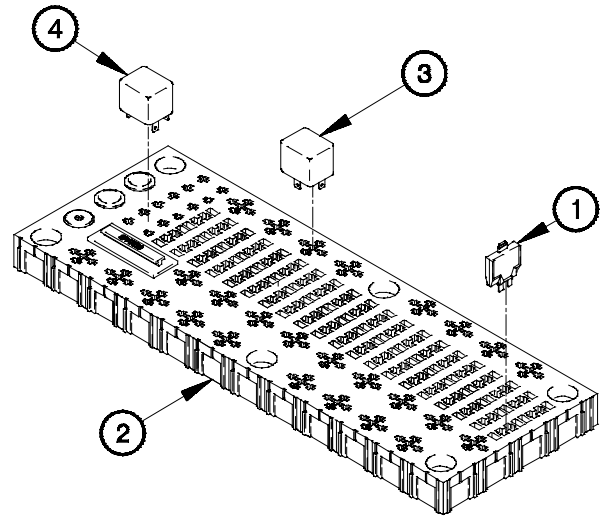

XG10C011

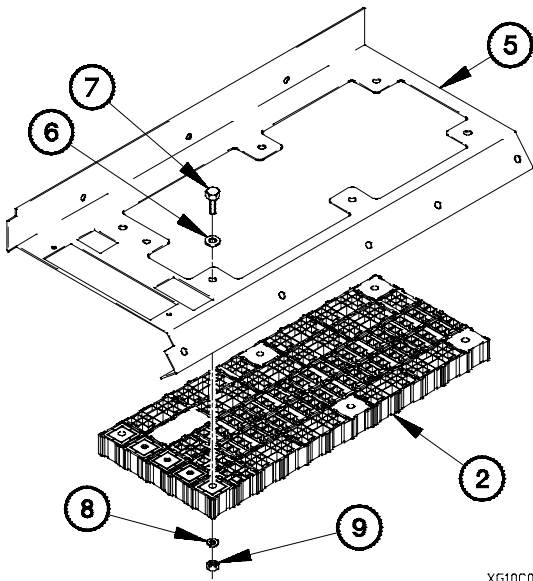

XG10C021

- (4) Position PDP (2) on PDP frame (5) with six washers (6), screws (7), lockwashers (8), and nuts (9).
- (5) Tighten six nuts (9) to 46-57 lb-ft (63-77 N-m).

- (6) Install 41 terminals (10) on PDP (2).
- (7) Install 41 retaining locks (11) on PDP (2).

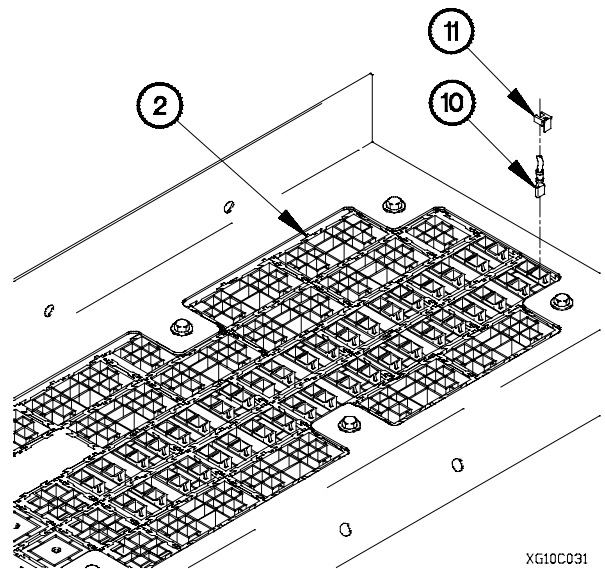

XG10C031

- (8) Install bus bar X2 (12) on PDP (2).
- (9) Install bus bar X6 (13) on PDP (2).
- (10) Install bus bar X1 (14) on PDP (2).
- (11) Install 94 terminals (15) on PDP (2).
- (12) Install 94 retaining locks (16) on PDP (2).

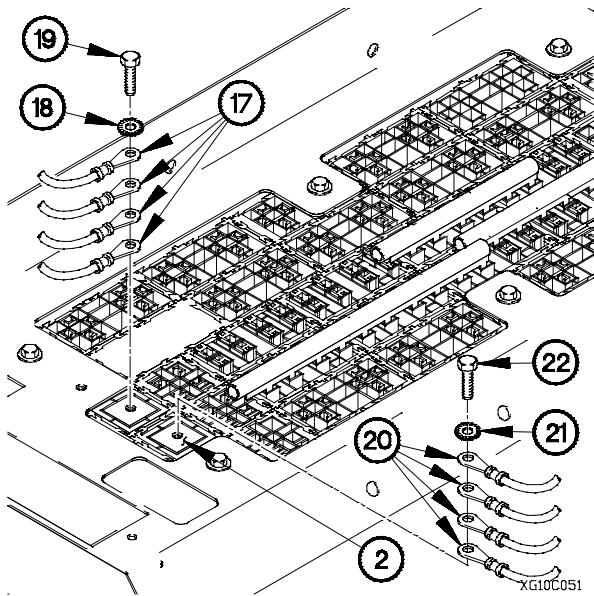
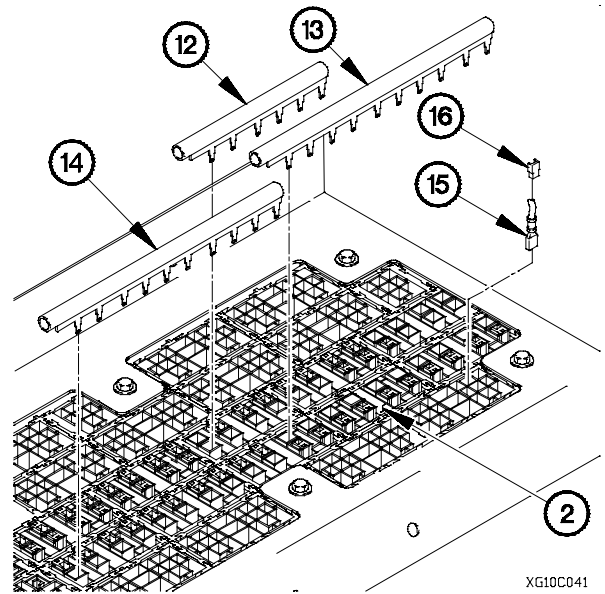

- (13) Position four terminal lugs (17) on PDP (2) with lockwasher (18), and screw (19).
- (14) Position four terminal lugs (20) on PDP (2) with lockwasher (21), and screw (22).

- (15) Push in two locking tabs (23) and install connector PX21 (24) through front of PDP frame (5).
- (16) Install six quick disconnect terminals (25) in connector PX21 (24).

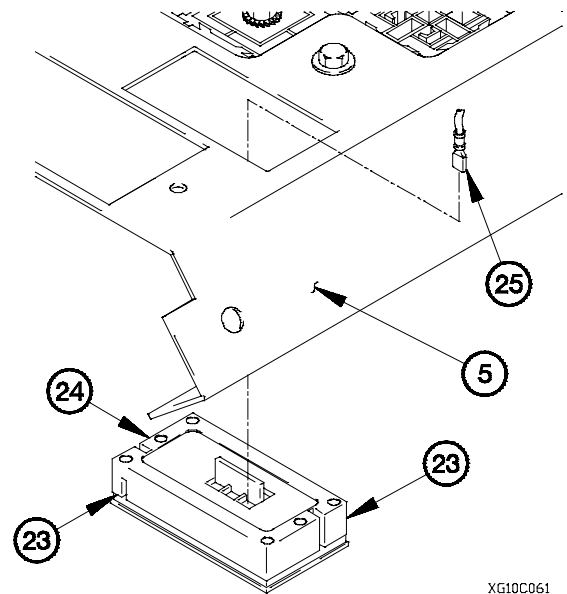

7-10. WTEC II DASHBOARD CABLE ASSEMBLY REPLACEMENT/REPAIR (CONT)

(17) Install terminal board TB1 (26) on PDP frame (5) with two screws (27), spacers (28), spacers (29), washers (30), lockwashers (31), and nuts (32).

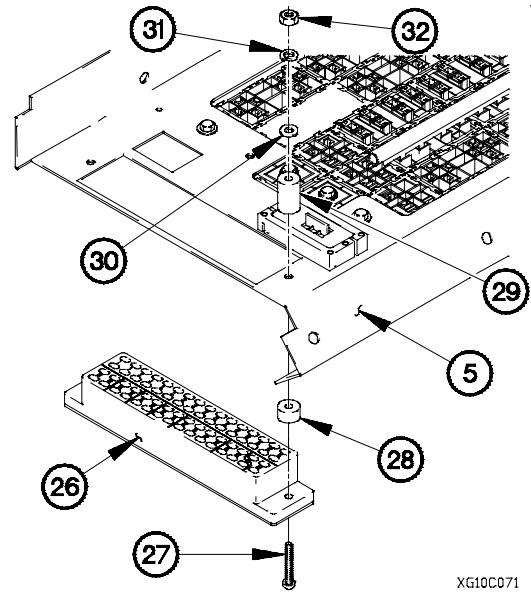

XG10C071

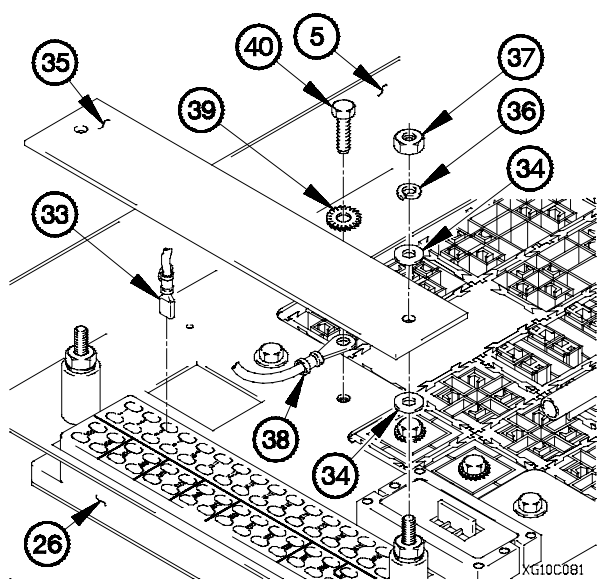

- (18) Install 40 quick disconnect terminals (33) on terminal board TB1 (26) positions 5, 9, 11, 19, 20, 22, 23, 24, 26, 27, 28, 29, 30, 31, 33, 34, 35, 36, 37, 38, 39, 40, 41, 42, 43, 46, 47, 50, 51, 52, 53, 54, 56, 57, 59, 60, 61, 62, 63, and 64.
- (19) Position two washers (34) and cover (35) on terminal board TB1 (26) with two washers (34), lockwashers (36), and nuts (37).
- (20) Position wire 1603 (38) on PDP frame (5) with lockwasher (39), and screw (40).

- (21) Install terminal board TB2 (41) on PDP frame (5) with two screws (42), lockwashers (43), and nuts (44).
- (22) Install 42 quick disconnect terminals (45) on terminal board TB2 (41) positions 3, 8, 9, 10, 11, 14, 16, 17, 18, 20, 21, 22, 23, 24, 25, 26, 28, 30, 31, 32, 33, 34, 35, 36, 37, 39, 43, 44, 45, 46, 47, 50, 53, 55, 56, 58, 60, 62, 70, 74, 77, and 79.
- (23) Position wire 1603 (38) on terminal board TB2 (41) with washer (46), lockwasher (47), and nut (48).

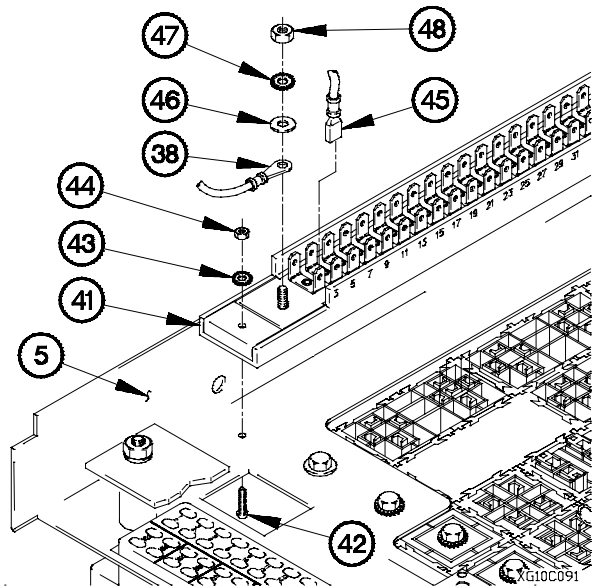

d. Installation.

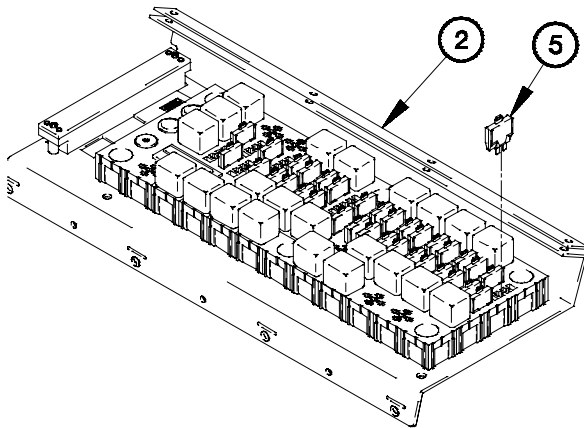

- (1) Deleted
- (2) Deleted
- (3) Deleted
- (4) Install circuit breaker CB68 (5) on PDP (2).

7-10. WTEC II DASHBOARD CABLE ASSEMBLY REPLACEMENT/REPAIR (CONT)

(5) Install relay K15 (6) on PDP (2).

NOTE

Perform steps (6) and (7) on M1084/
M1086/M1088 and M1089.

(6) Install circuit breaker CB72 (7) on PDP (2).

(7) Install relay K12 (8) on PDP (2).

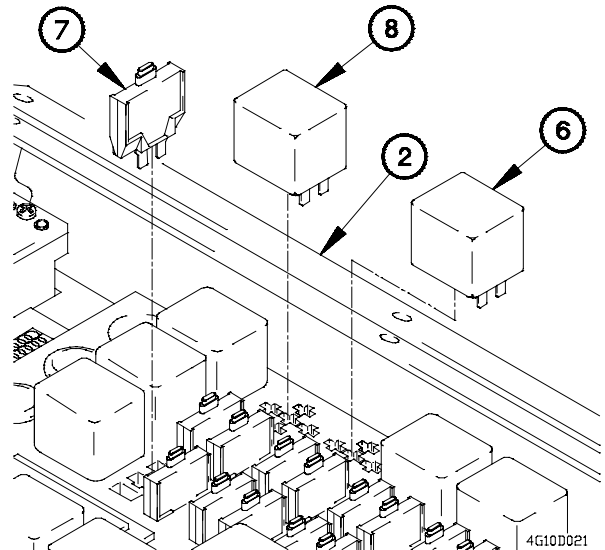

NOTE

- Step (8) requires the aid of an assistant.
- Install plastic cable ties as required.

(8) Position WTEC II dashboard cable assembly (9) in dashboard (10).

(9) Install terminal lug TL14 (11) on terminal board TB2 (12) position 12.

(10) Install terminal lug TL87 (13) on terminal board TB2 (12) position 6.

(11) Remove two nuts (14), lockwashers (15), washers (16), cover (17), and two washers (16) from terminal board TB1 (18).

(12) Install terminal lug TL75 (19) on terminal board TB1 (18) position 2.

(13) Install terminal lug TL71 (20) on terminal board TB2 (12) position 2.

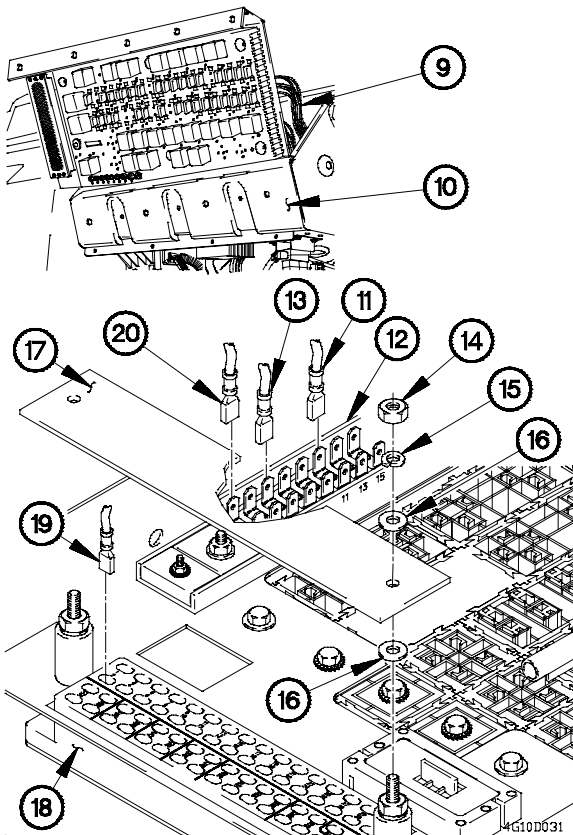

- (14) Install terminal lug TL73 (21) on terminal board TB1 (18) position 1.
- (15) Install terminal lug TL74 (22) on terminal board TB1 (18) position 3.
- (16) Install two washers (16) and cover (17) on terminal board TB1 (18) with two washers (16), lockwashers (15), and nuts (14).
- (17) Install terminal lug TL86 (23) on terminal board TB2 (12) position 4.

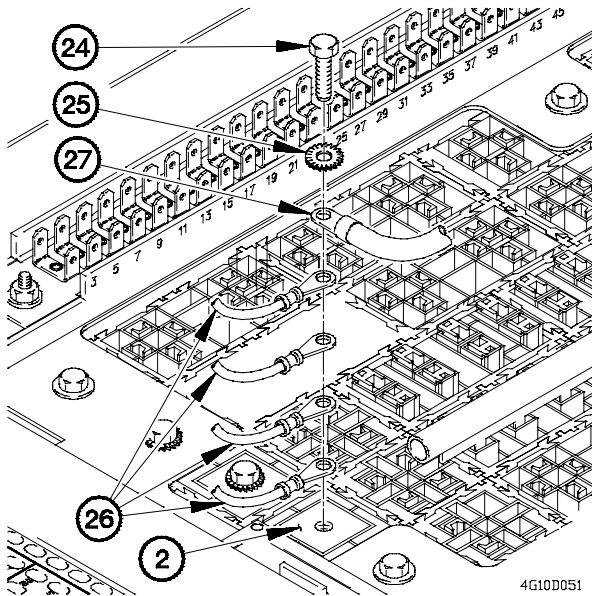
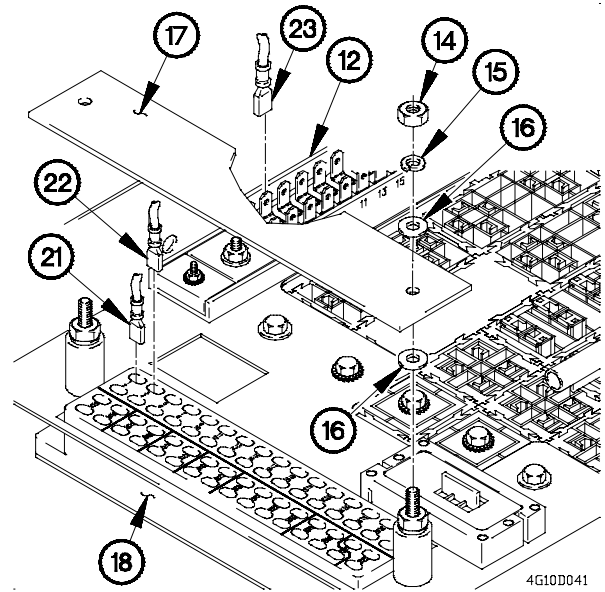

- (18) Remove screw (24), lockwasher (25), and four terminal lugs (26) from PDP (2).
- (19) Position four terminal lugs (26) and terminal lug TL42 (27) on PDP (2) with lockwasher (25), and screw (24).
- (20) Tighten screw (24) to 35-45 lb-in. (4-5 N-m).

- (21) Remove screw (28), lockwasher (29), and four terminal lugs (30) from PDP (2).
- (22) Position four terminal lugs (30) and terminal lug TL41 (31) on PDP (2) with lockwasher (29) and screw (28).
- (23) Tighten screw (28) to 35-45 lb-in. (4-5 N-m).
- (24) Remove screw (32), lockwasher (33), and terminal lug (34) from PDP (2).
- (25) Position terminal lug (34) and terminal lug TL56 (35) on PDP (2) with lockwasher (33) and screw (32).
- (26) Tighten screw (32) to 35-45 lb-in. (4-5 N-m).

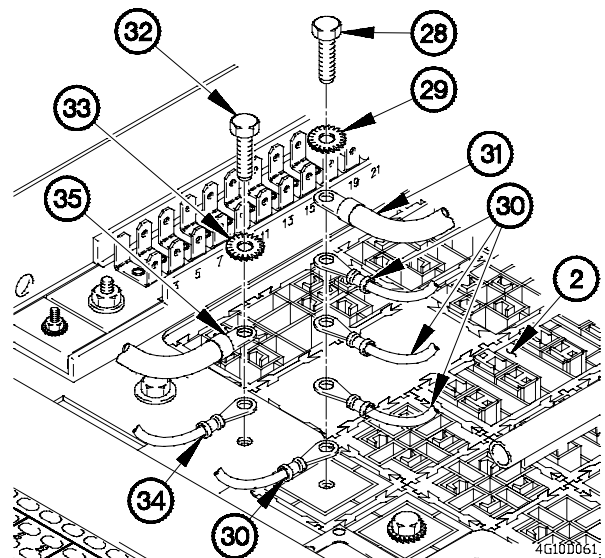

7-10. WTEC II DASHBOARD CABLE ASSEMBLY REPLACEMENT/REPAIR (CONT)

(27) Connect WTEC II TEPSS dimmer module (36) to connector J7 (37).

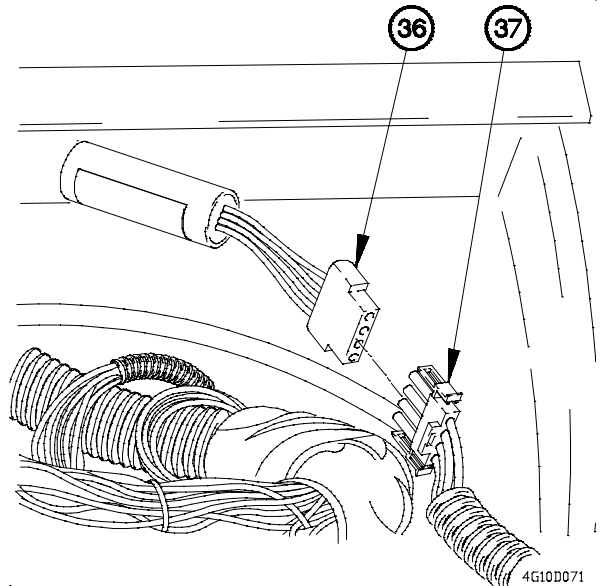

4G10D071

NOTE

Perform step (28) on M1088.

(28) Install terminal lugs TL502 (38) and TL501 (39) on terminal studs (40 and 41) with two lockwashers (42) and nuts (43).

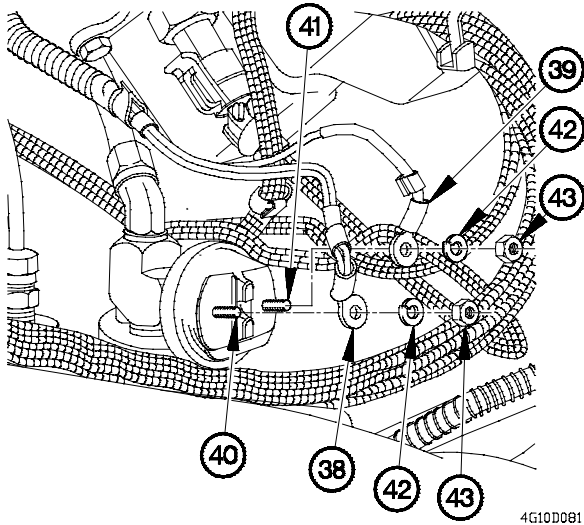

4G10D081

NOTE

Perform step (29) on vehicles equipped with cab radio.

(29) Connect connector P78 (44) to connector J78 (45).

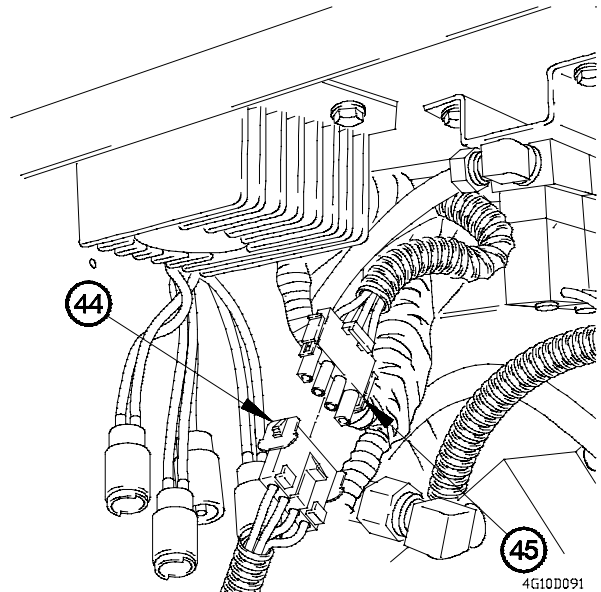

4G10D091

- (30) Connect connector PX33 (46) to WTEC II VIM (47).
- (31) Tighten captive screw (48) in connector PX33 (46).

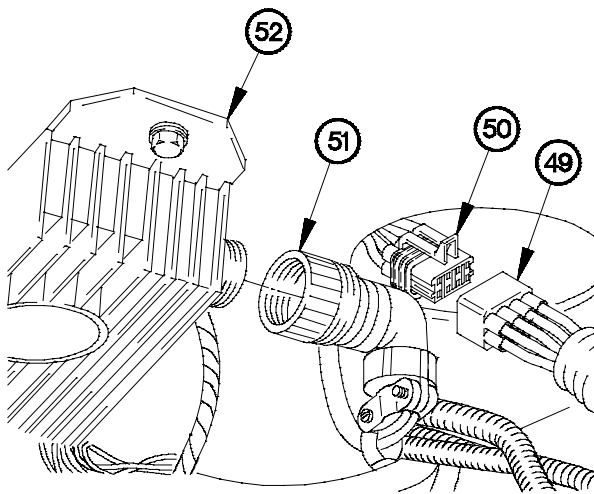
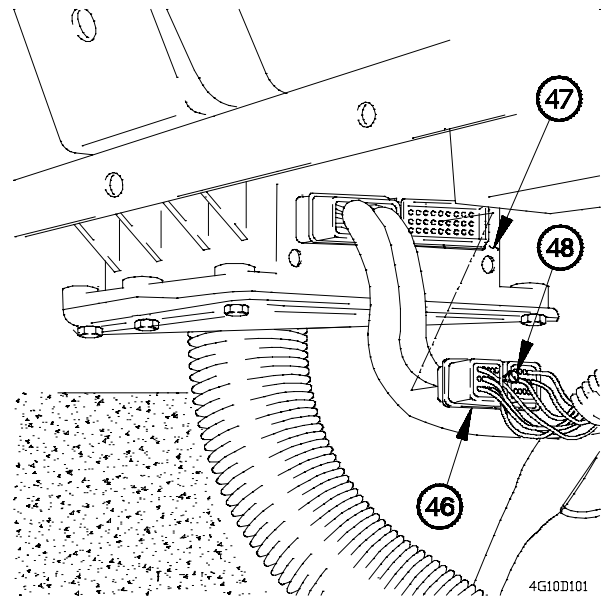

- (32) Connect connector P111 (49) to connector J111 (50).
- (33) Connect connector PX20 (51) to flasher module (52).

- (34) Connect connector J99 (53) to chemical alarm kit cable connector P99 (54).
- (35) Connect connector P65 (55) to warning light cable connector J65 (56).
- (36) Connect differential lock solenoid connector (57) to connector PX50 (58).
- (37) Connect fan solenoid connector (59) to connector PX34 (60).

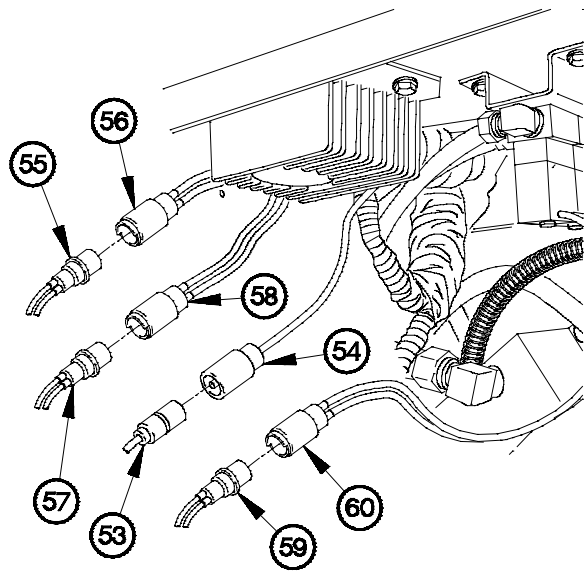

4G10D121

7-10. WTEC II DASHBOARD CABLE ASSEMBLY REPLACEMENT/REPAIR (CONT)

- (38) Connect connector P51 (61) to connector J51 (62).
- (39) Connect connector P27 (63) to connector J27 (64).

NOTE

Perform step (40) on vehicles not equipped with auxiliary panel.

- (40) Connect connector P912A (65) to connector J912 (66).

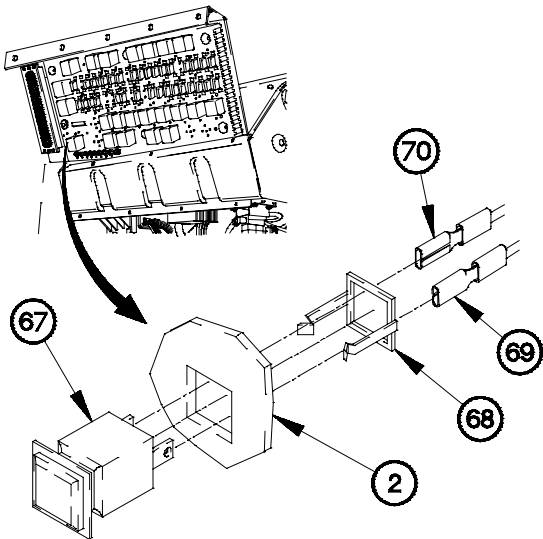
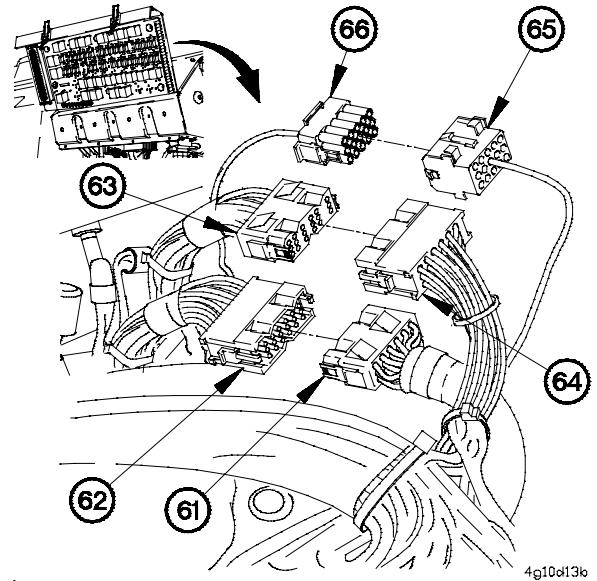

- (41) Position start inhibit pushbutton switch (67) in PDP (2).
- (42) Install spring clip (68) on start inhibit pushbutton switch (67).
- (43) Connect terminal lugs TL159 (69) and TL158 (70) to start inhibit pushbutton switch (67).

- (44) Install windshield wiper ECU (71) on PDP (2).

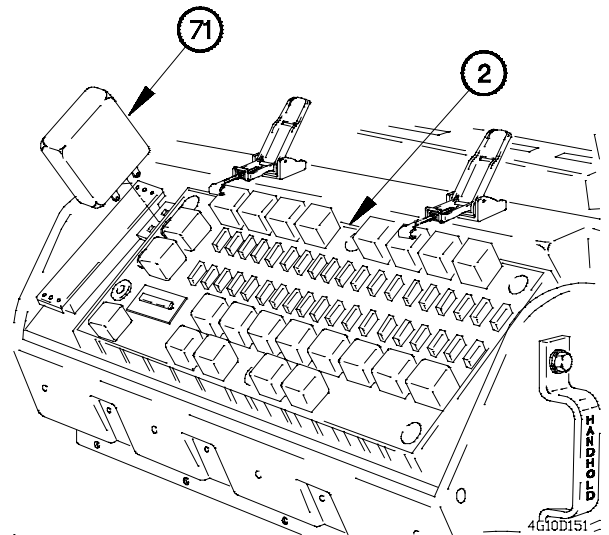

NOTE

Perform steps (45) and (46) on vehicles equipped with auxiliary panel.

(45) Connect connector P913 (72) to connector J913 (73).

(46) Connect connector P912 (74) to connector J912 (66).

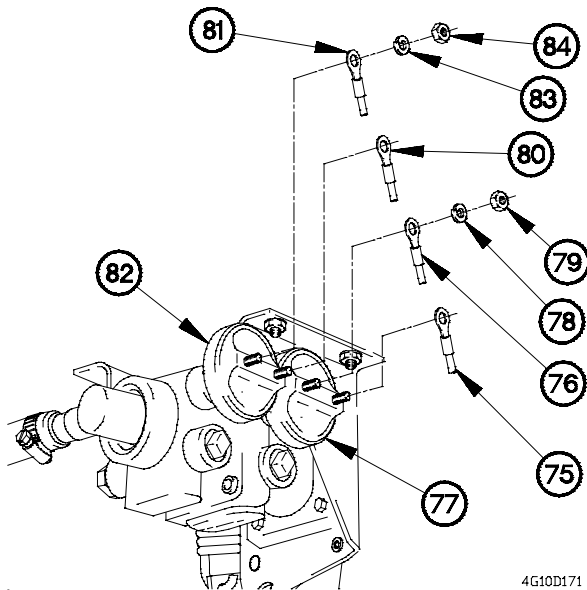
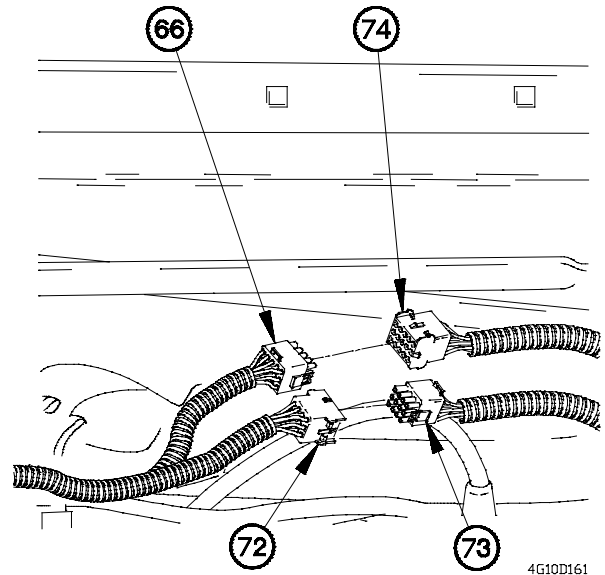

(47) Install terminal lugs TL155 (75) and TL154 (76) on front stoplight switch (77) with two lockwashers (78) and nuts (79).

(48) Install terminal lugs TL152 (80) and TL153 (81) on rear stoplight switch (82) with two lockwashers (83) and nuts (84).

(49) Install terminal lug TL156 (85) on rear brake air pressure transmitter terminal G (86) with lockwasher (87) and nut (88).

(50) Install terminal lug TL150 (89) on rear brake air pressure transmitter terminal WK (90) with lockwasher (91) and nut (92).

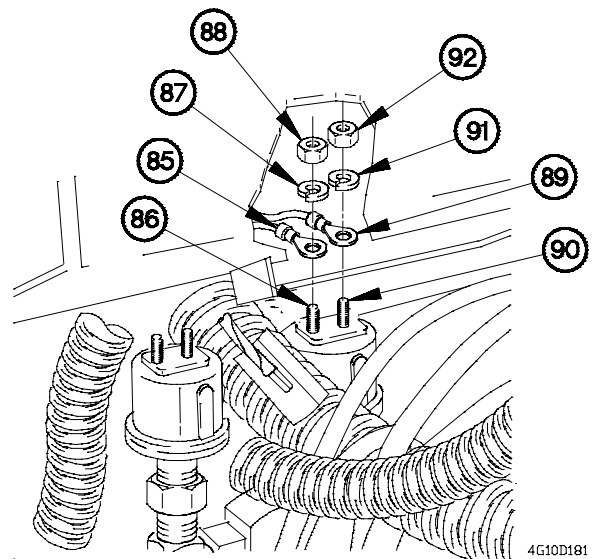

7-10. WTEC II DASHBOARD CABLE ASSEMBLY REPLACEMENT/REPAIR (CONT)

- (51) Install terminal lug TL157 (93) on front brake air pressure transmitter terminal G (94) with lockwasher (95) and nut (96).
- (52) Install terminal lug TL151 (97) on front brake air pressure transmitter terminal WK (98) with lockwasher (99) and nut (100).

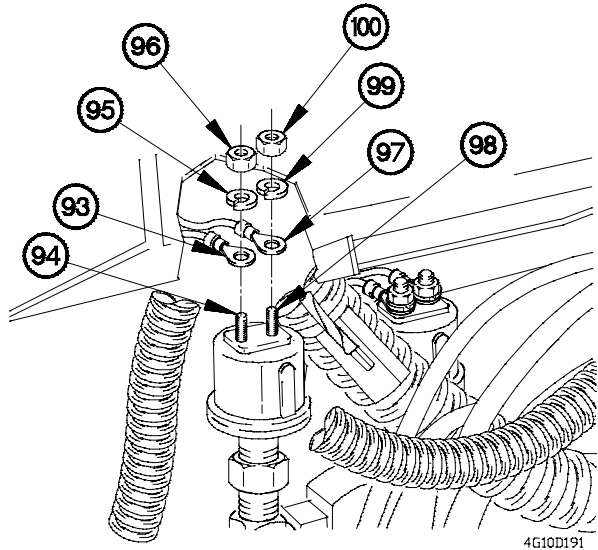

4G10D191

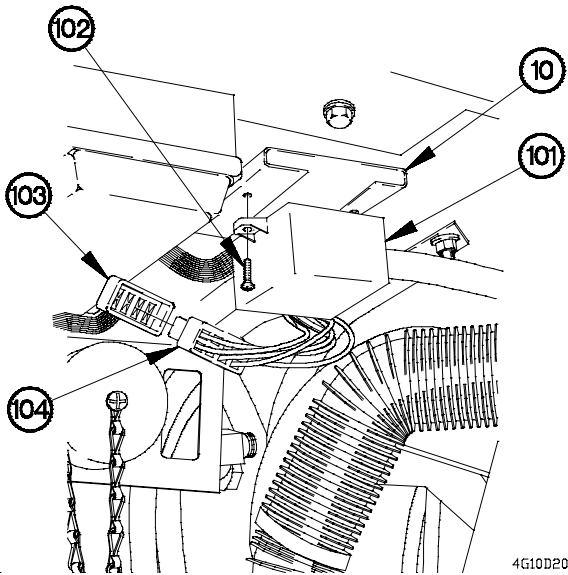

4G10D201

- (53) Install frequency ECU (101) on left side dashboard (10) with two screws (102).
- (54) Connect connector PX26 (103) to frequency ECU connector (104).

- (55) Position clamp (105) on WTEC II dashboard cable assembly (9).
- (56) Position clamp (105) on dashboard (10) with washer (106) and screw (107).
- (57) Tighten screw (107) to 35-45 lb-in. (4-5 N·m).

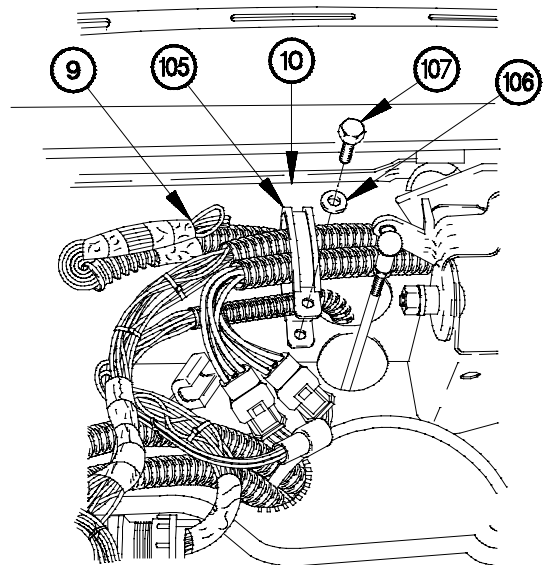

4G10D211

(58) Connect connector J31 (108) to connector P31 (109).

(59) Connect connector J43 (110) to connector P43 (111).

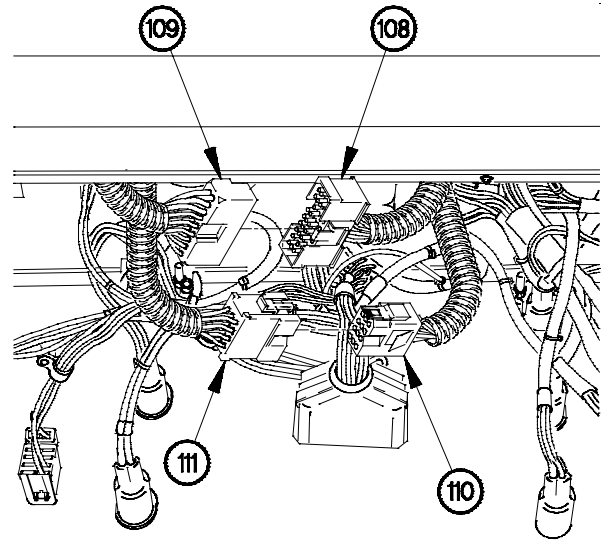

4G10D221

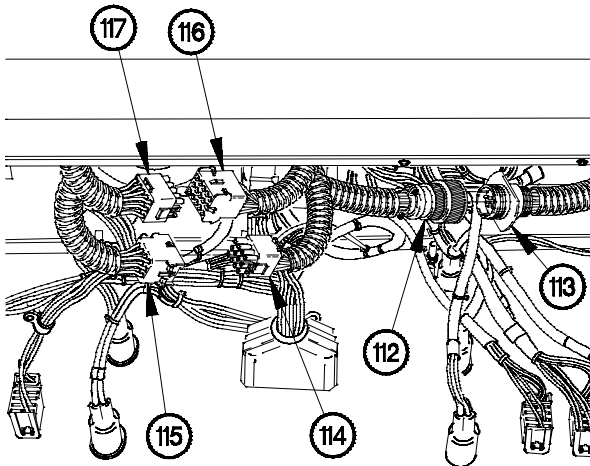

4G10D231

(60) Connect connector P118 (112) to connector J118 (113).

(61) Connect steering column switch connector P18 (114) to connector J18 (115).

(62) Connect steering column switch connector J19 (116) to connector P19 (117).

e. Follow-On Maintenance.

- (1) Install windshield wiper motor (para 18-4).
- (2) Install personnel heater (para 18-9).
- (3) Install instrument panel assembly (para 7-15).
- (4) Start engine (TM 9-2320-366-10-1).
- (5) Check instruments operation (TM 9-2320-366-10-1).
- (6) Shut down engine (TM 9-2320-366-10-1).

End of Task.

7-11. WTEC III DASHBOARD CABLE ASSEMBLY REPLACEMENT/REPAIR

This task covers:

- a. Removal
- b. Disassembly
- c. Assembly
- d. Installation
- e. Follow-On Maintenance

INITIAL SETUP

Equipment Conditions
 Windshield wiper motor removed (para 18-4).
 Personnel heater removed (para 18-9).
 Instrument panel assembly removed (para 7-15).

Tools and Special Tools
 Tool Kit, Auto Fuel (Item 43, Appendix C)
 Tool Kit, Genl Mech (Item 46, Appendix C)
 Wrench, Torque, 0-175 lb-ft (Item 58, Appendix C)
 Wrench, Torque, 0-200 lb-in. (Item 59, Appendix C)
 Socket Set, Socket Wrench (Item 34, Appendix C)

Materials/Parts
 Dispenser, Pressure Sensitive Adhesive Tape (Item 20, Appendix D)
 Ties, Cable, Plastic (Item 69, Appendix D)
 Lockwasher (4) (Item 71, Appendix G)
 Lockwasher (6) (Item 93, Appendix G)
 Lockwasher (2) (Item 84, Appendix G)
 Lockwasher (11) (Item 83, Appendix G)
 Lockwasher (4) (Item 88, Appendix G)

Personnel Required
 (2)

a. Removal.

NOTE

- Remove plastic cable ties as required.
- Tag wires and connection points prior to disconnecting.

- (1) Disconnect steering column switch connector J19 (1) from connector P19 (2).
- (2) Disconnect steering column switch connector P18 (3) from connector J18 (4).

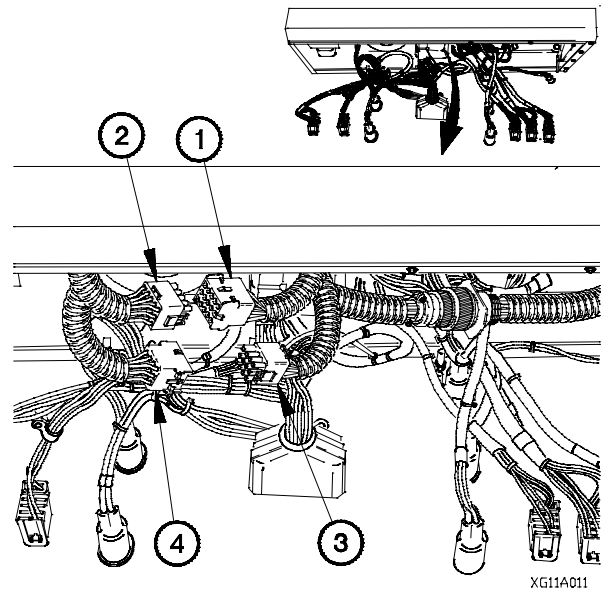

- (3) Disconnect connector J43 (5) from connector P43 (6).
- (4) Disconnect connector J31 (7) from connector P31 (8).

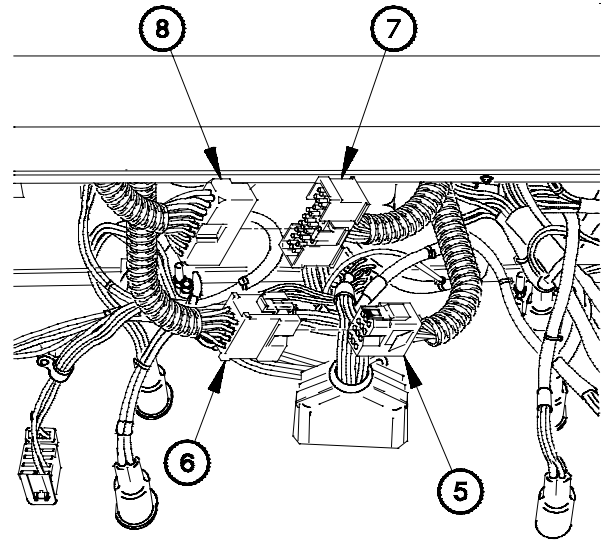

XG11A021

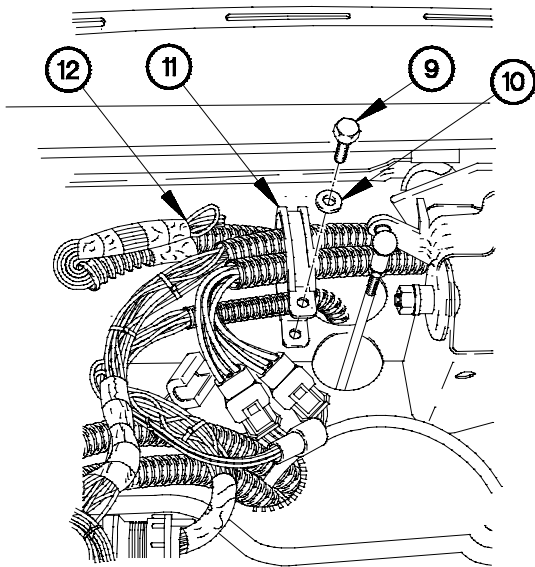

XG11A031

- (5) Remove screw (9), washer (10), and clamp (11) from WTEC III dashboard cable assembly (12).

- (6) Disconnect connector PX26 (13) from frequency ECU connector (14).
- (7) Remove two screws (15) and frequency ECU (16) from left side dashboard (17).

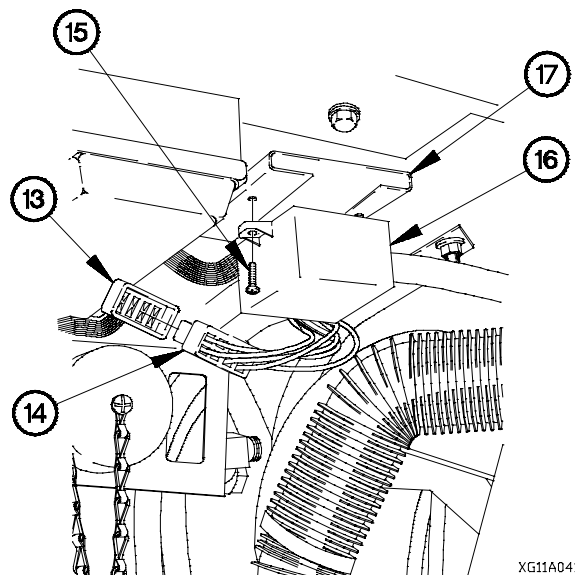

XG11A041

7-11. WTEC III DASHBOARD CABLE ASSEMBLY REPLACEMENT/REPAIR (CONT)

(8) Remove nut (18), lockwasher (19), and terminal lug TL151 (20) from front brake air pressure transmitter terminal WK (21). Discard lockwasher.

(9) Remove nut (22), lockwasher (23), and terminal lug TL157 (24) from front brake air pressure transmitter terminal G (25). Discard lockwasher.

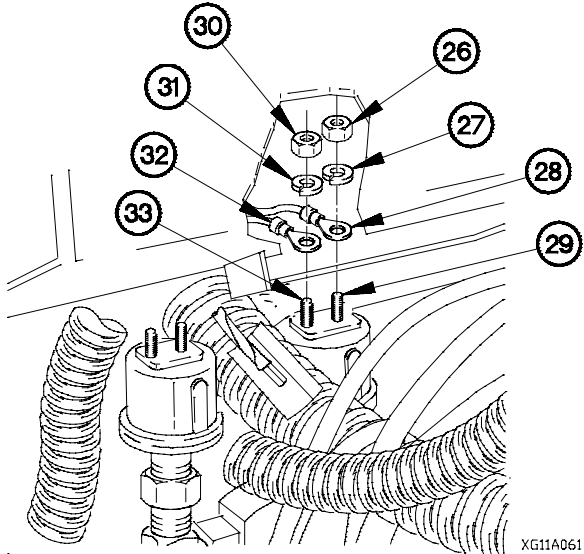
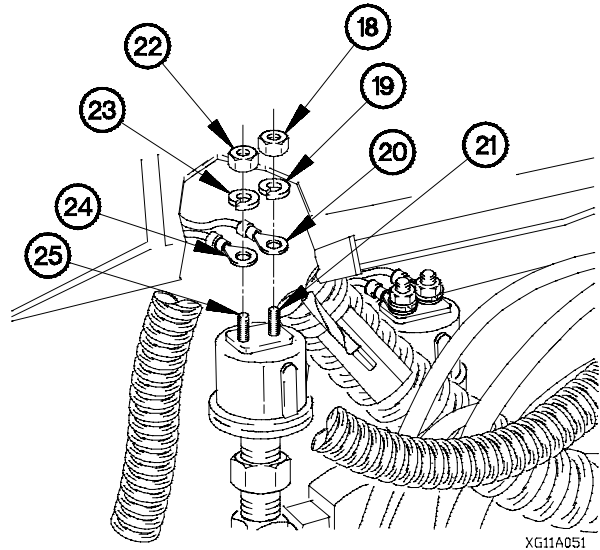

(10) Remove nut (26), lockwasher (27), and terminal lug TL150 (28) from rear brake air pressure transmitter terminal WK (29). Discard lockwasher.

(11) Remove nut (30), lockwasher (31), and terminal lug TL156 (32) from rear brake air pressure transmitter terminal G (33). Discard lockwasher.

(12) Remove two nuts (34), lockwashers (35), and terminal lugs TL153 (36) and TL152 (37) from rear stoplight switch (38). Discard lockwashers.

(13) Remove two nuts (39), lockwashers (40), and terminal lugs TL154 (41) and TL155 (42) from front stoplight switch (43). Discard lockwashers.

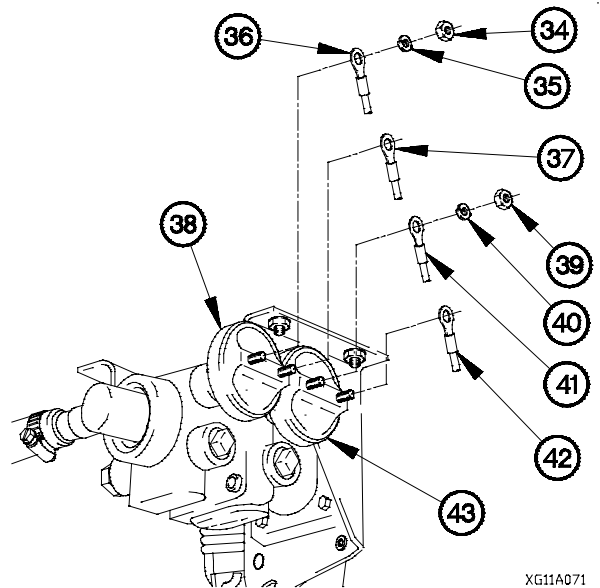

NOTE

Perform steps (14) and (15) on vehicles equipped with auxiliary panel.

- (14) Disconnect connector J912 (44) from connector P912 (45)
- (15) Disconnect connector P913 (46) from connector J913 (47).

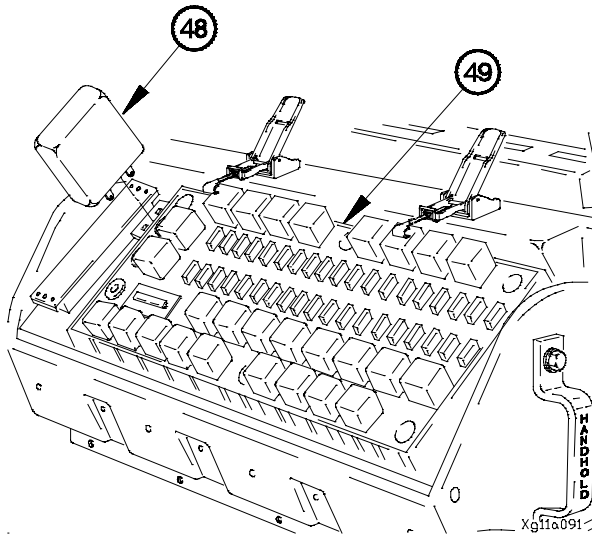
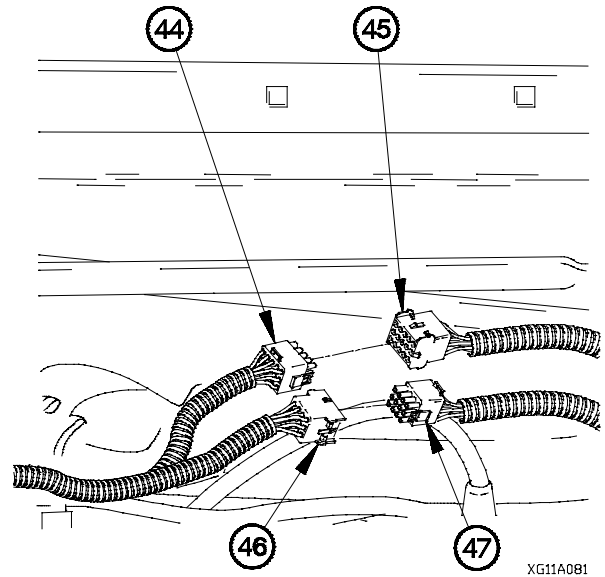

- (16) Remove windshield wiper ECU (48) from PDP (49).

- (17) Disconnect terminal lugs TL158 (50) and TL159 (51) from start inhibit pushbutton switch (52).
- (18) Remove spring clip (53) from start inhibit pushbutton switch (52).
- (19) Remove start inhibit pushbutton switch (52) from PDP (49).

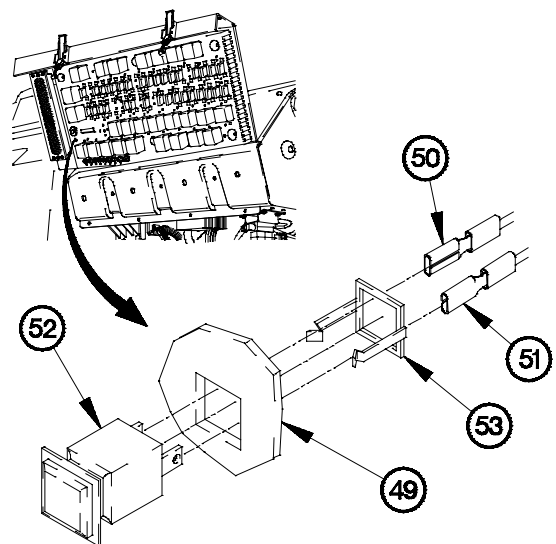

7-11. WTEC III DASHBOARD CABLE ASSEMBLY REPLACEMENT/REPAIR (CONT)

NOTE

Perform step (20) on vehicles not equipped with auxiliary panel.

- (20) Disconnect connector P912A (54) from connector J912 (44).
- (21) Disconnect connector J27 (55) from connector P27 (56).
- (22) Disconnect connector J51 (57) from connector P51 (58).

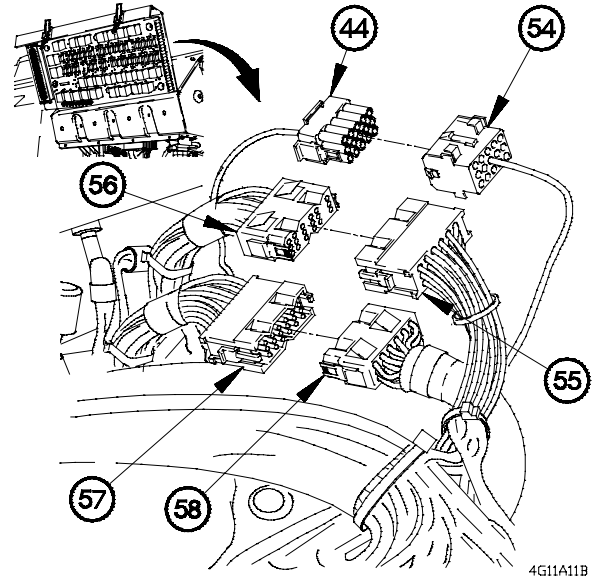

4G11A11B

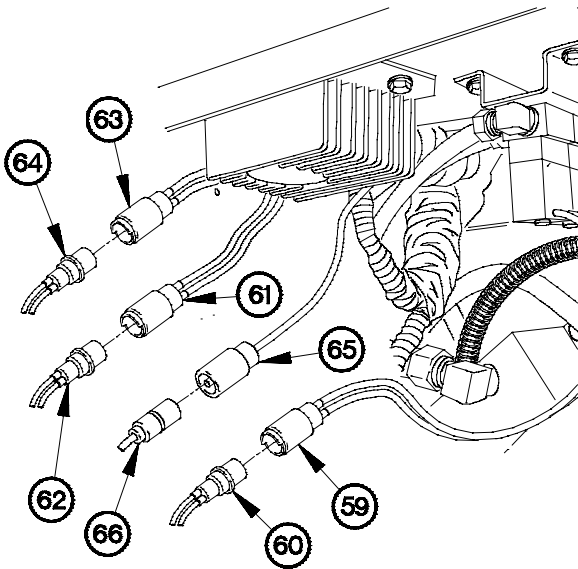

4G11A121

- (23) Disconnect connector PX34 (59) from fan solenoid connector (60).
- (24) Disconnect connector PX50 (61) from differential solenoid connector (62).
- (25) Disconnect connector J65 (63) from warning light cable connector P65 (64).
- (26) Disconnect connector P99 (65) from chemical alarm kit cable connector J99 (66).

- (27) Disconnect connector PX20 (67) from flasher module (68).
- (28) Disconnect connector P111 (69) from connector J111 (70).

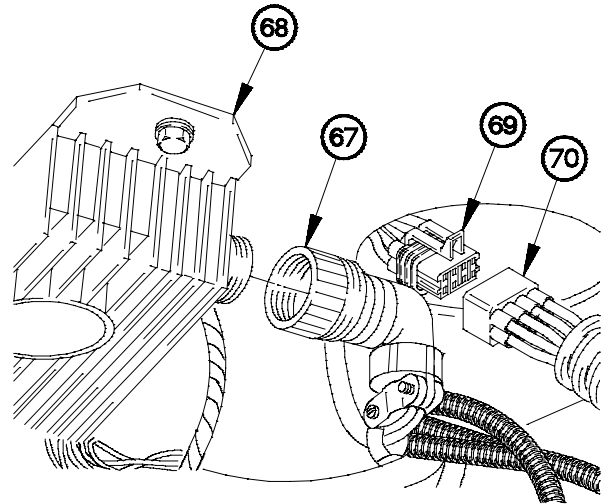

4G11A131

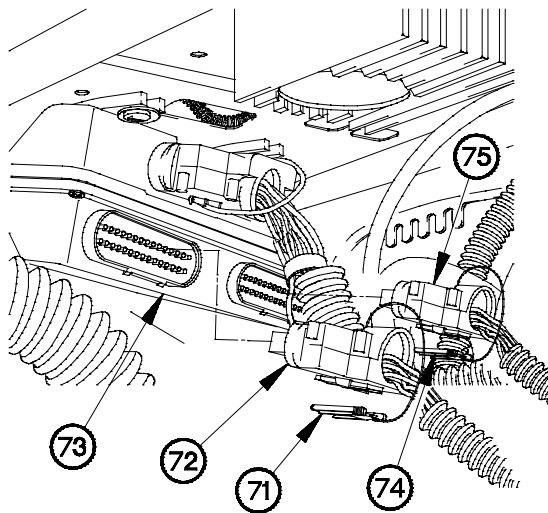

4G11A141

- (29) Disconnect connector clamp (71) from connector P115 (72).
- (30) Disconnect connector P115 (72) from WTEC III transmission ECU (73).
- (31) Disconnect connector clamp (74) from connector P116 (75).
- (32) Disconnect connector P116 (75) from WTEC III transmission ECU (73).

NOTE

Perform step (33) on vehicles equipped with cab radio.

- (33) Disconnect connector J78 (76) from connector P78 (77).

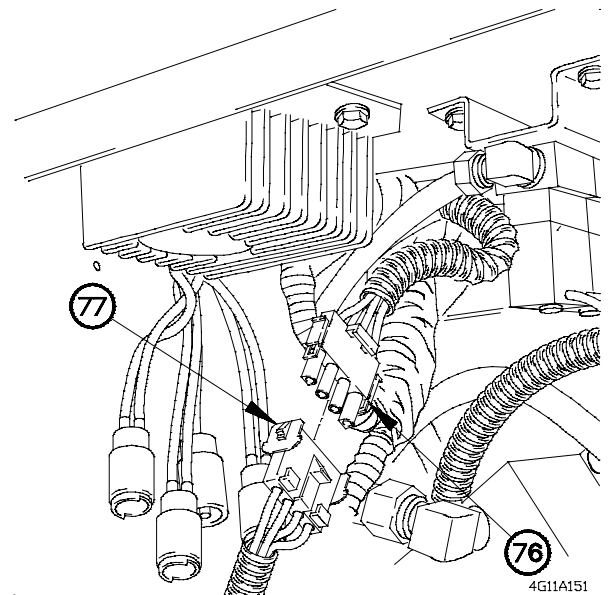

4G11A151

7-11. WTEC III DASHBOARD CABLE ASSEMBLY REPLACEMENT/REPAIR (CONT)

NOTE

Perform step (34) on M1088.

- (34) Remove two nuts (78), lockwashers (79), and terminal lugs TL501 (80) and TL502 (81) from terminal studs (82 and 83). Discard lockwashers.

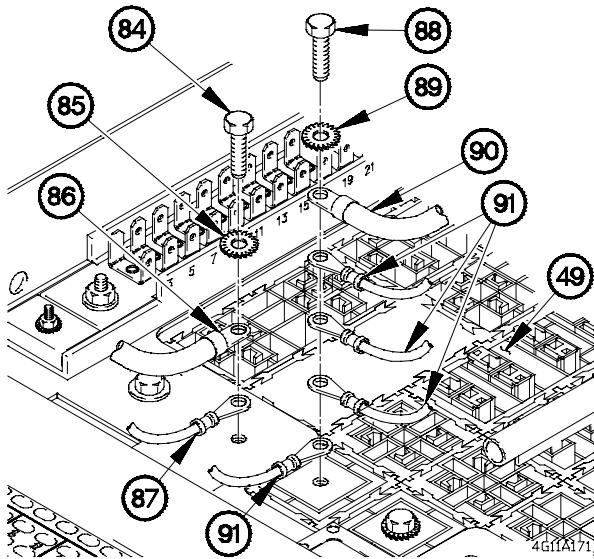
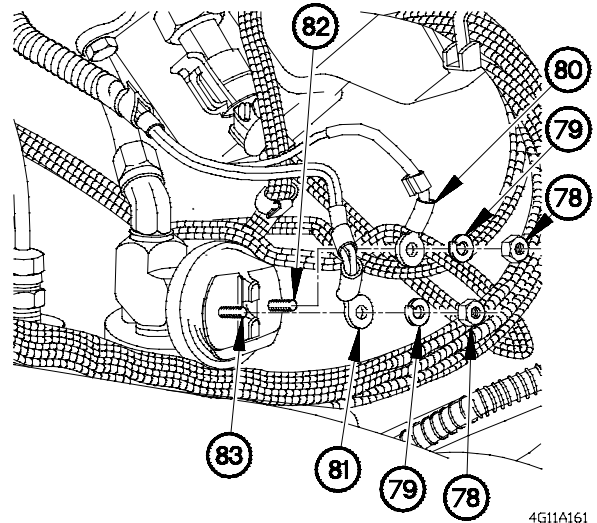

- (35) Remove screw (84), lockwasher (85), terminal lug TL56 (86), and terminal lug (87) from PDP (49).

- (36) Position terminal lug (87) on PDP (49) with lockwasher (85) and screw (84).

- (37) Remove screw (88), lockwasher (89), terminal lug TL41 (90), and four terminal lugs (91) from PDP (49).

- (38) Position four terminal lugs (91) on PDP (49) with lockwasher (89) and screw (88).

- (39) Remove screw (92), lockwasher (93), terminal lug TL42 (94), and four terminal lugs (95) from PDP (49).

- (40) Position four terminal lugs (95) on PDP (49) with lockwasher (93), and screw (92).

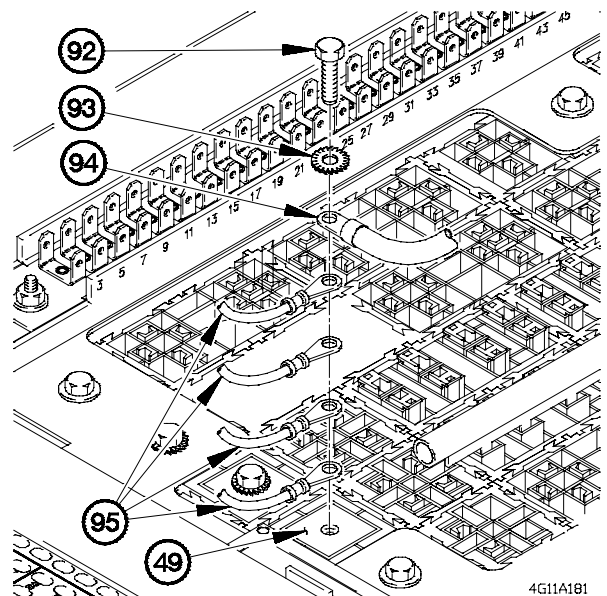

- (41) Remove terminal lug TL86 (96) from terminal board TB2 (97) position 4.
- (42) Remove two nuts (98), lockwashers (99), washers (100), cover (101), and two washers (100) from terminal board TB1 (102).
- (43) Remove terminal lug TL74 (103) from terminal board TB1 (102) position 3.
- (44) Remove terminal lug TL73 (104) from terminal board TB1 (102) position 1.

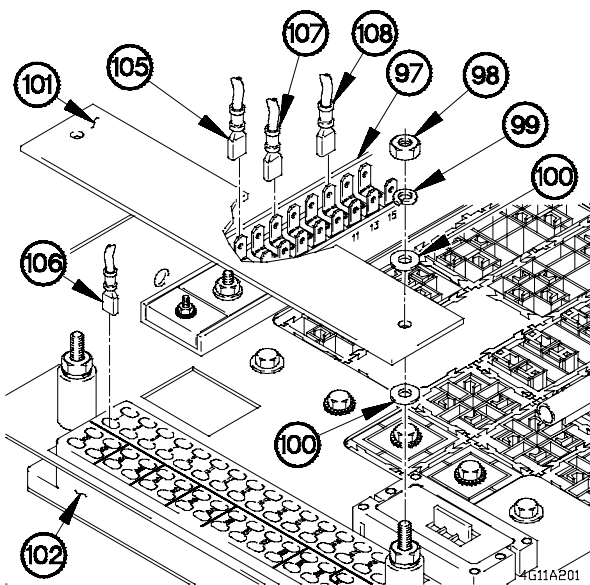
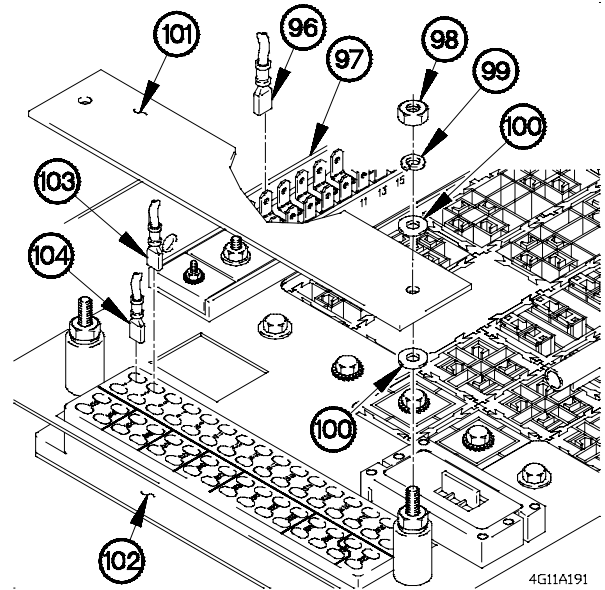

- (45) Remove terminal lug TL71 (105) from terminal board TB2 (97) position 2.
- (46) Remove terminal lug TL75 (106) from terminal board TB1 (102) position 2.
- (47) Position two washers (100) and cover (101) on terminal board TB1 (102) with two washers (100), lockwashers (99), and nuts (98).
- (48) Remove terminal lug TL87 (107) from terminal board TB2 (97) position 6.
- (49) Remove terminal lug TL14 (108) from terminal board TB2 (97) position 12.

7-11. WTEC III DASHBOARD CABLE ASSEMBLY REPLACEMENT/REPAIR (CONT)

(50) Remove nut (109), lockwasher (110), terminal lug TL190 (111), terminal lug TL57 (112), two washers (113), and screw (114) from dashboard (17). Discard lockwasher.

NOTE

Step (51) requires the aid of an assistant.

(51) Remove WTEC III dashboard cable assembly (12) from dashboard (17).

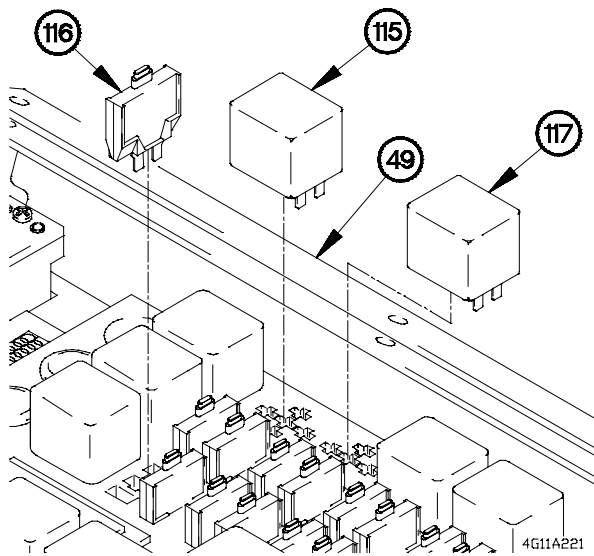
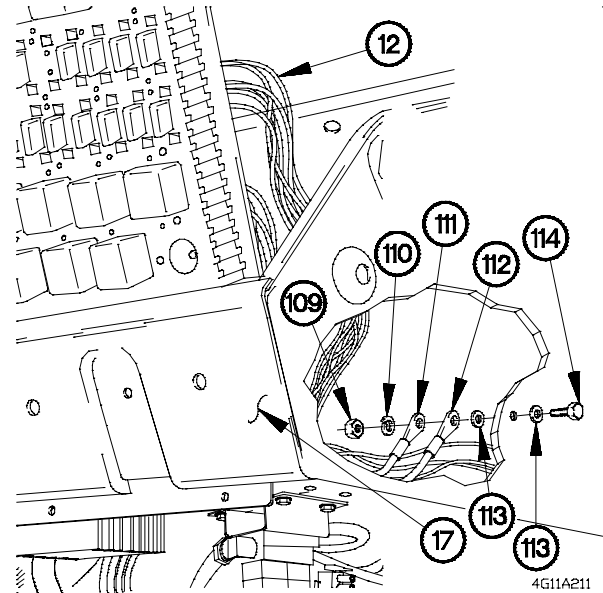

NOTE

- Perform steps (52) and (53) on M1084/M1086/M1088 and M1089.
- Tag relays and circuit breaker prior to removal.

- (52) Remove relay K12 (115) from PDP (49).
- (53) Remove circuit breaker CB72 (116) from PDP (49).
- (54) Remove relay K15 (117) from PDP (49).

(55) Remove circuit breaker CB68 (118) from PDP (49).

(56) Deleted

(57) Deleted

(58) Deleted

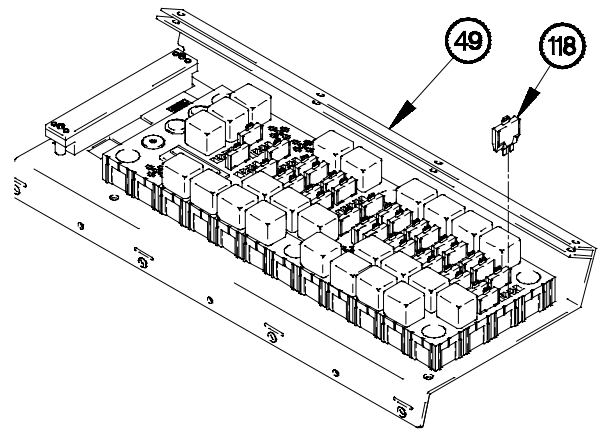

4g11a23b

b. Disassembly.

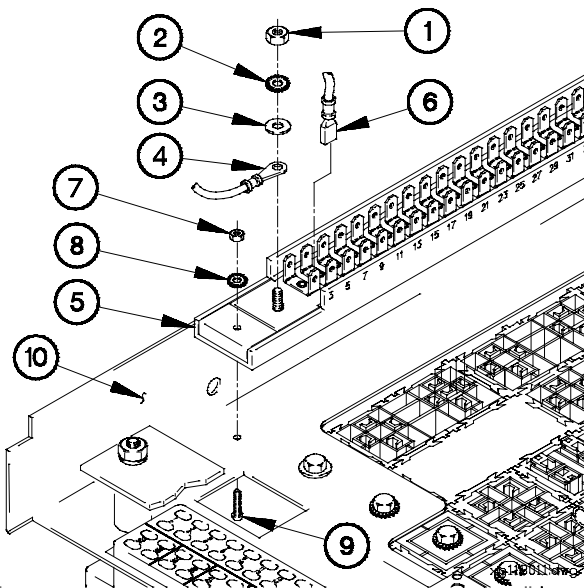

NOTE

Tag wires and connection points prior to removal.

- (1) Remove nut (1), lockwasher (2), washer (3), and wire 1603 (4) from terminal board TB2 (5). Discard lockwasher.
- (2) Remove 46 quick disconnect terminals (6) from terminal board TB2 (5) positions 3, 8, 9, 10, 11, 13, 14, 15, 16, 17, 18, 20, 21, 22, 23, 24, 25, 26, 27, 28, 29, 30, 31, 32, 33, 34, 35, 36, 37, 39, 40, 43, 44, 45, 46, 47, 50, 53, 55, 56, 60, 62, 70, 74, 77, and 79.
- (3) Remove two nuts (7), lockwashers (8), screws (9), and terminal board TB2 (5) from PDP frame (10). Discard lockwashers.

7-11. WTEC III DASHBOARD CABLE ASSEMBLY REPLACEMENT/REPAIR (CONT)

- (4) Remove screw (11), lockwasher (12), and wire 1603 (4) from PDP frame (10). Discard lockwasher.
- (5) Remove two nuts (13), lockwashers (14), washers (15), cover (16), and two washers (15) from terminal board TB1 (17). Discard lockwashers.
- (6) Remove 38 quick disconnect terminals (18) from terminal board TB1 (17) positions 5, 11, 20, 23, 24, 26, 27, 28, 29, 30, 31, 33, 34, 35, 36, 37, 38, 39, 40, 41, 42, 43, 46, 47, 50, 51, 52, 53, 54, 56, 57, 58, 59, 60, 61, 62, 63, and 64.

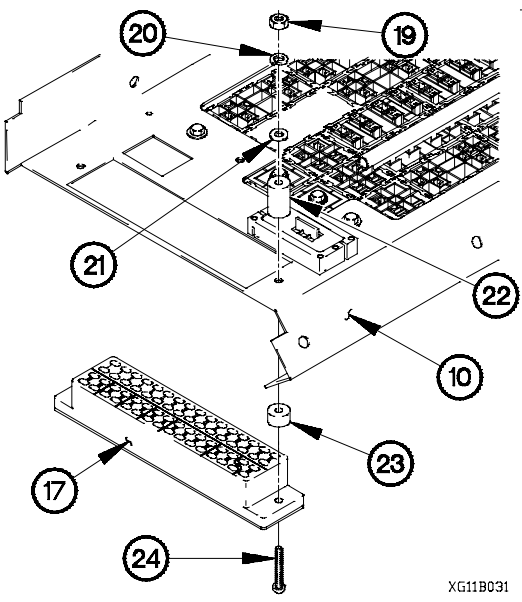
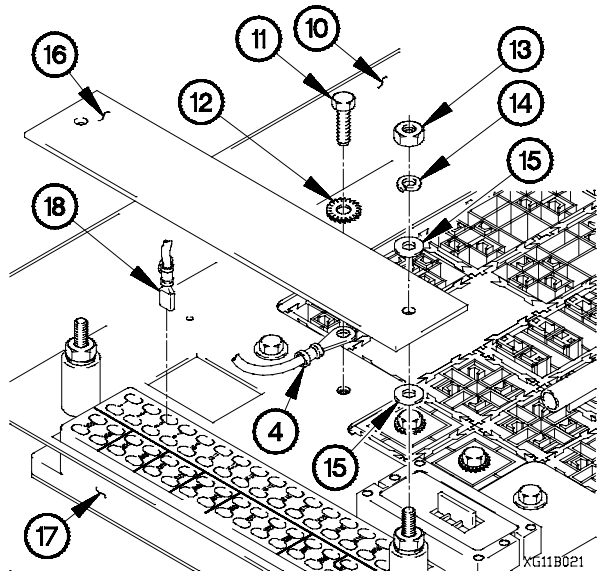

- (7) Remove two nuts (19), lockwashers (20), washers (21), spacers (22), terminal board TB1 (17), two spacers (23), and screws (24) from PDP frame (10). Discard lockwashers.

- (8) Remove six quick disconnect terminals (25) from connector PX21 (26).
- (9) Push in two locking tabs (27) and remove connector PX21 (26) from front of PDP frame (10).

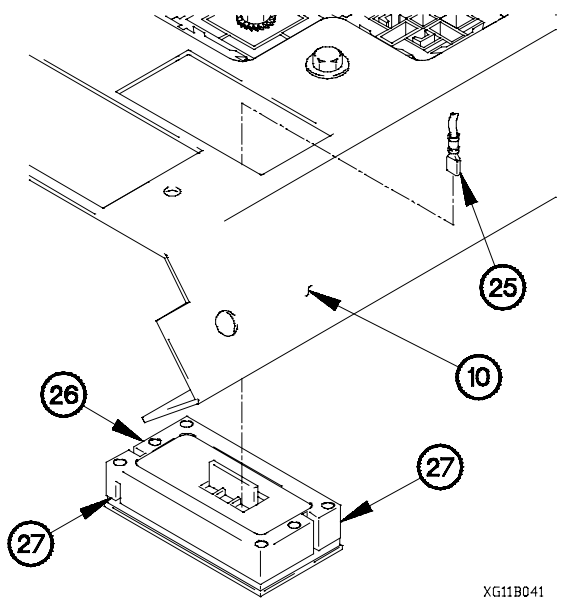

NOTE

Tag terminal lugs and connection points prior to removal.

(10) Remove screw (28), lockwasher (29), and four terminal lugs (30) from PDP (31). Discard lockwasher.

(11) Remove screw (32), lockwasher (33), and four terminal lugs (34) from PDP (31). Discard lockwasher.

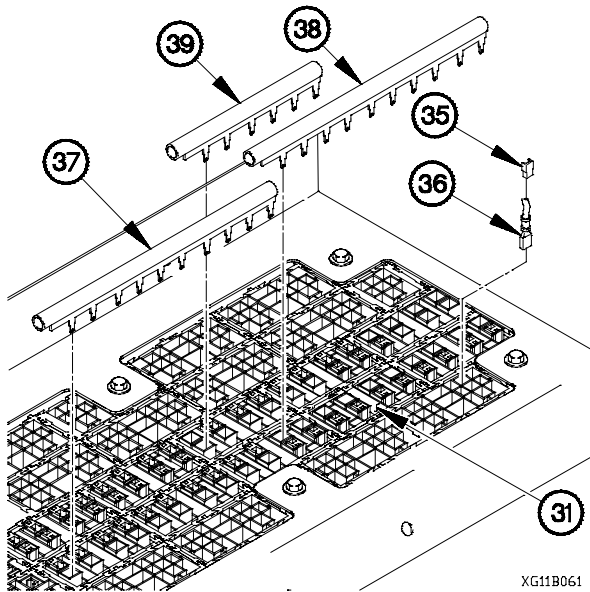
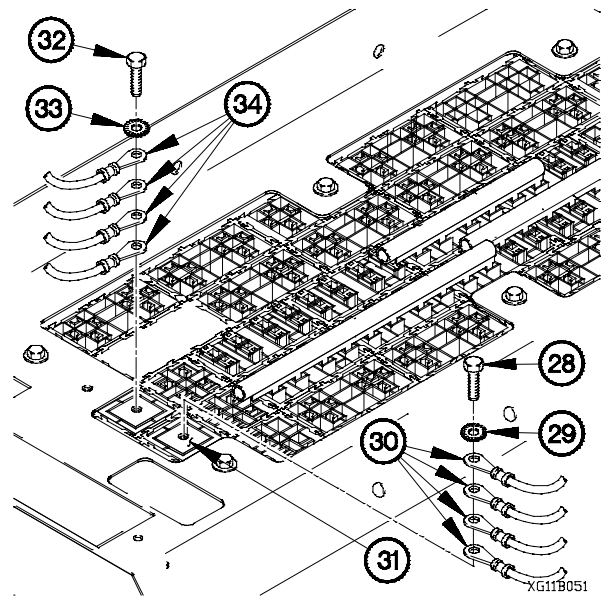

(12) Remove 94 retaining locks (35) from PDP (31).

(13) Remove 94 terminals (36) from PDP (31).

(14) Remove bus bar X1 (37) from PDP (31).

(15) Remove bus bar X6 (38) from PDP (31).

(16) Remove bus bar X2 (39) from PDP (31).

(17) Remove 41 retaining locks (40) from PDP (31).

(18) Remove 41 terminals (41) from PDP (31).

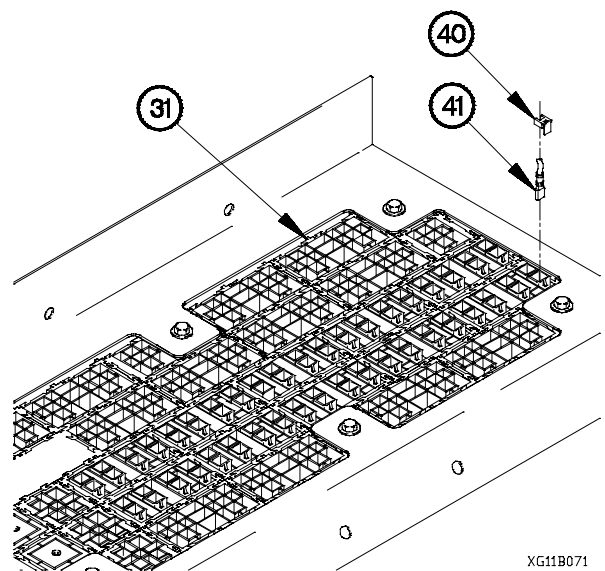

7-11. WTEC III DASHBOARD CABLE ASSEMBLY REPLACEMENT/REPAIR (CONT)

(19) Remove six nuts (42), lockwashers (43), screws (44), washers (45), and PDP (31) from PDP frame (10). Discard lockwashers.

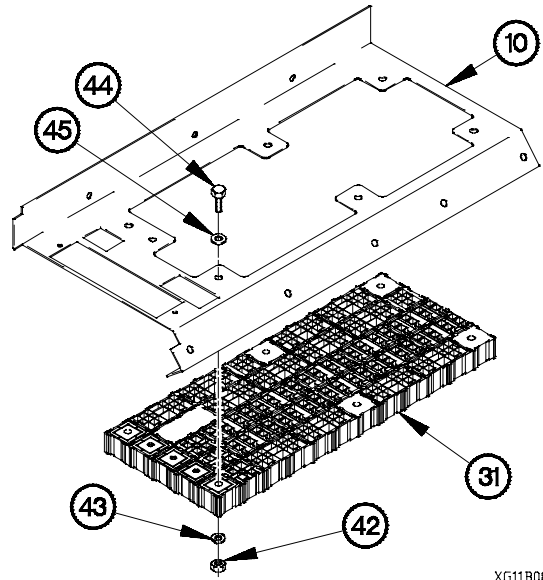

XG11B081

NOTE

Tag diodes, relays, and circuit breakers prior to removal.

(20) Remove three diodes (46) from PDP (31).

(21) Remove 24 relays (47) from PDP (31).

(22) Remove 29 circuit breakers (48) from PDP (31).

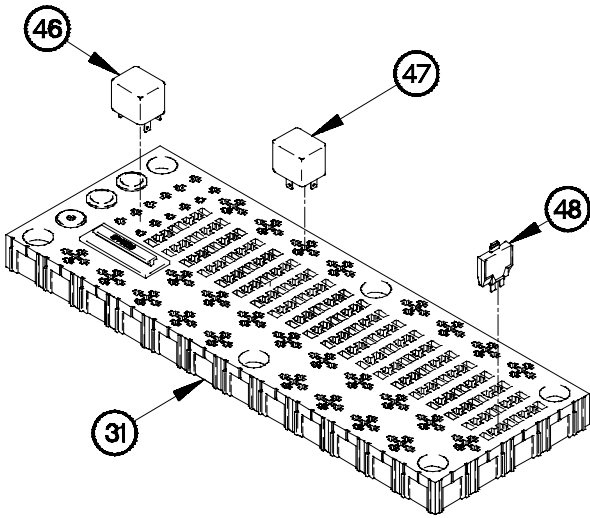

XG11B091

c. Assembly.

(1) Install 29 circuit breakers (1) on PDP (2).

(2) Install 24 relays (3) on PDP (2).

(3) Install three diodes (4) on PDP (2).

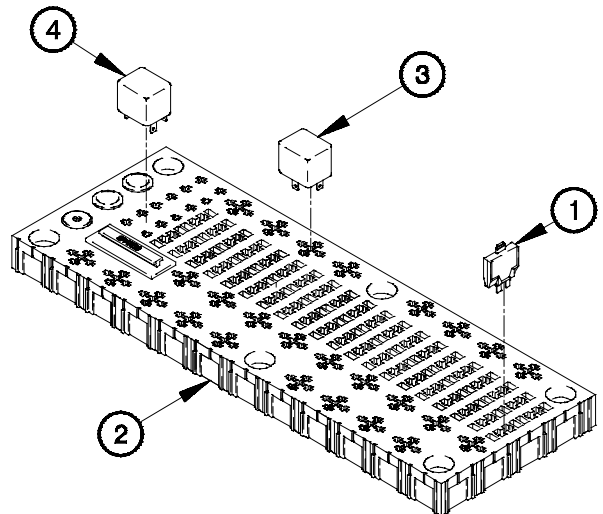

XG11C011

- (4) Position PDP (2) on PDP frame (5) with six washers (6), screws (7), lockwashers (8), and nuts (9).
- (5) Tighten six nuts (9) to 46-57 lb-ft (63-77 N-m).

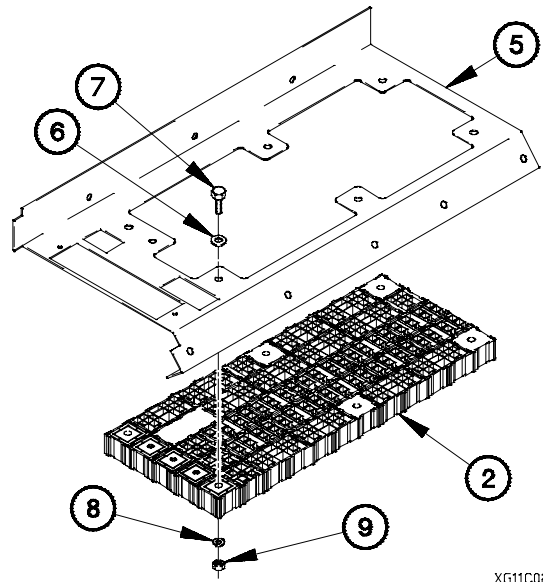

XG11C021

- (6) Install 41 terminals (10) on PDP (2).
- (7) Install 41 retaining locks (11) on PDP (2).

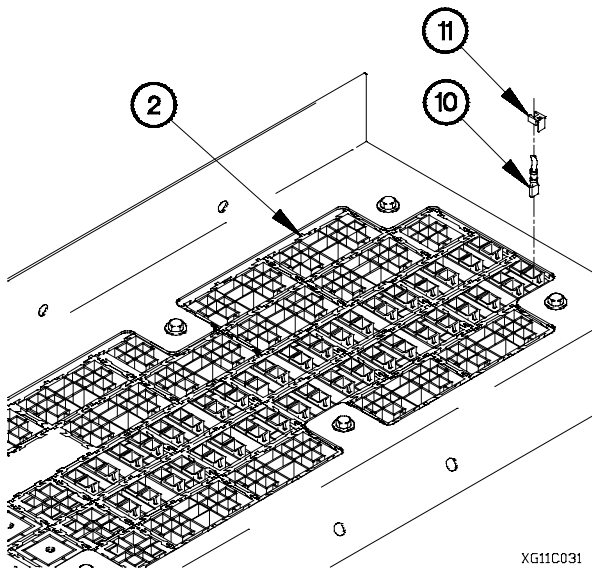

XG11C031

- (8) Install bus bar X2 (12) on PDP (2).
- (9) Install bus bar X6 (13) on PDP (2).
- (10) Install bus bar X1 (14) on PDP (2).
- (11) Install 94 terminals (15) on PDP (2).
- (12) Install 94 retaining locks (16) on PDP (2).

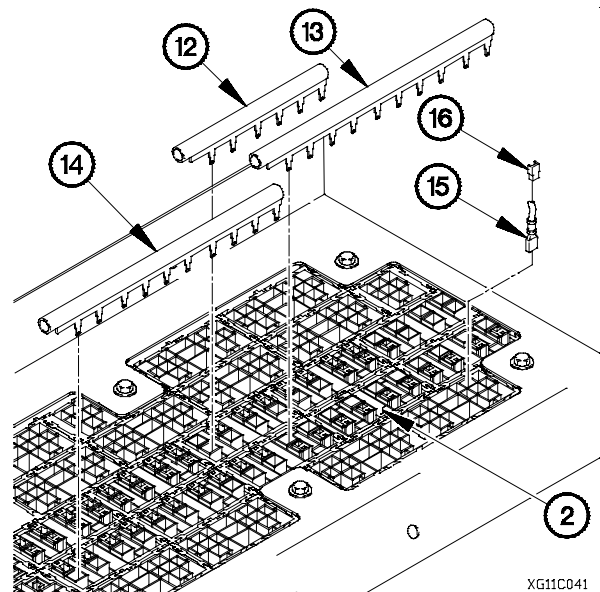

XG11C041

7-11. WTEC III DASHBOARD CABLE ASSEMBLY REPLACEMENT/REPAIR (CONT)

- (13) Position four terminal lugs (17) on PDP (2) with lockwasher (18), and screw (19).
- (14) Position four terminal lugs (20) on PDP (2) with lockwasher (21), and screw (22).

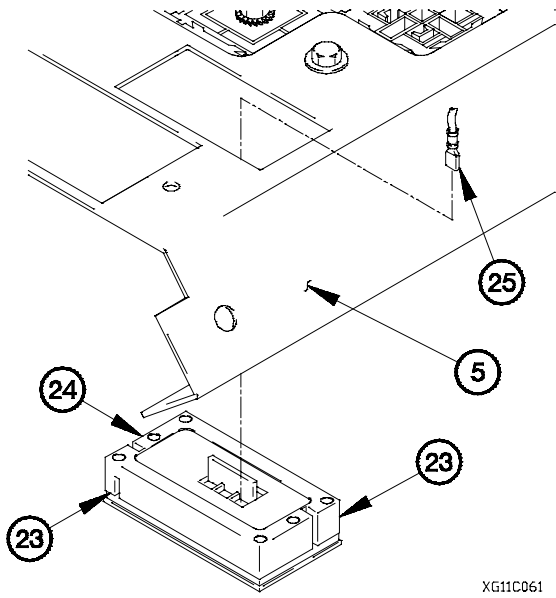
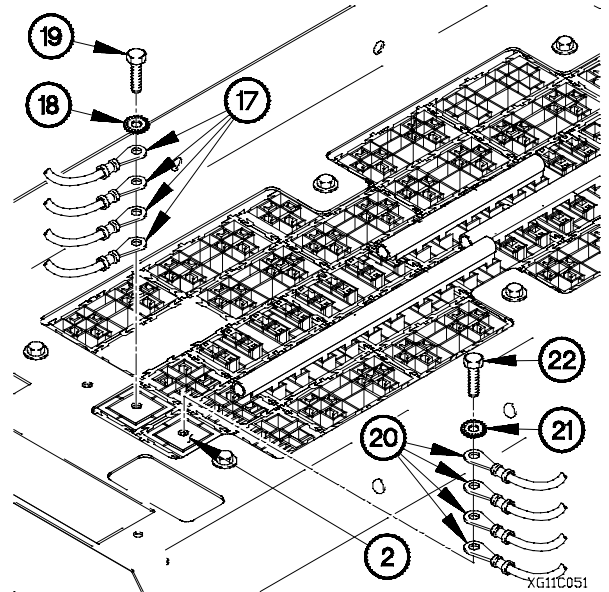

- (15) Push in two locking tabs (23) and install connector PX21 (24) through front of PDP frame (5).
- (16) Install six quick disconnect terminals (25) in connector PX21 (24).

- (17) Install terminal board TB1 (26) on PDP frame (5) with two screws (27), spacers (28), spacers (29), washers (30), lockwashers (31), and nuts (32).

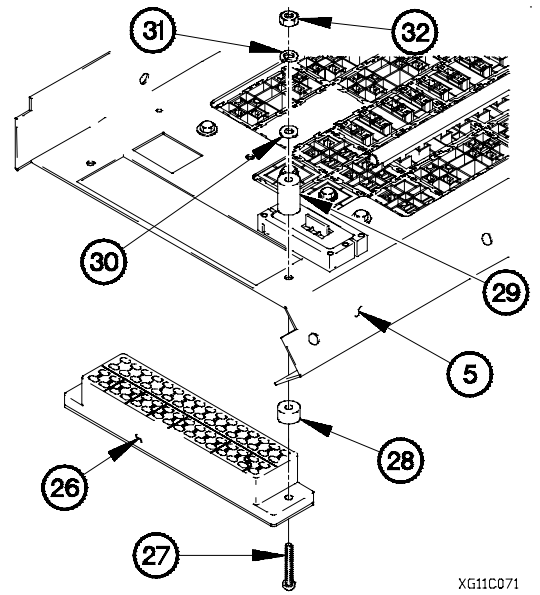

- (18) Install 38 quick disconnect terminals (33) on terminal board TB1 (26) positions 5, 11, 20, 23, 24, 26, 27, 28, 29, 30, 31, 33, 34, 35, 36, 37, 38, 39, 40, 41, 42, 43, 46, 47, 50, 51, 52, 53, 54, 56, 57, 58, 59, 60, 61, 62, 63, and 64.
- (19) Position two washers (34) and cover (35) on terminal board TB1 (26) with two washers (34), lockwashers (36), and nuts (37).
- (20) Position wire 1603 (38) on PDP frame (5) with lockwasher (39), and screw (40).

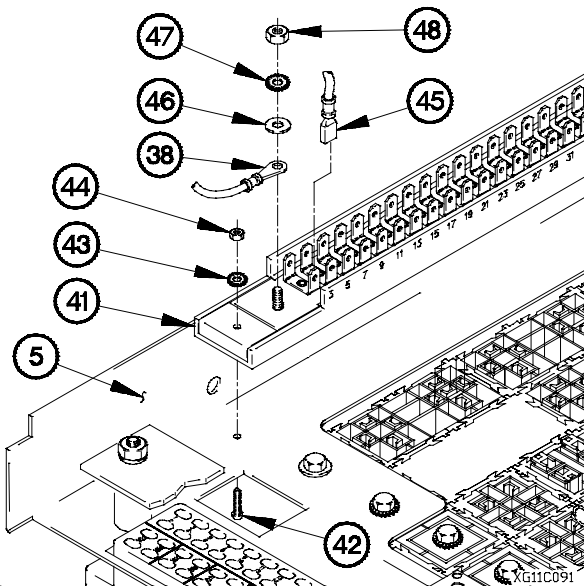
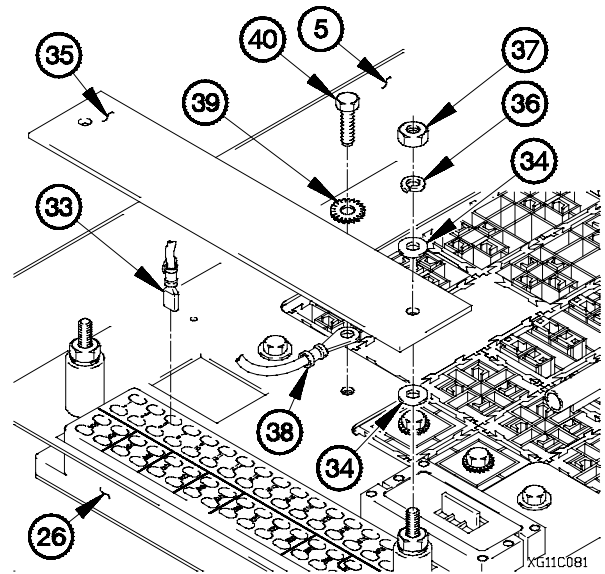

- (21) Install terminal board TB2 (41) on PDP frame (5) with two screws (42), lockwashers (43), and nuts (44).
- (22) Install 46 quick disconnect terminals (45) on terminal board TB2 (41) positions 3, 8, 9, 10, 11, 13, 14, 15, 16, 17, 18, 20, 21, 22, 23, 24, 25, 26, 27, 28, 29, 30, 31, 32, 33, 34, 35, 36, 37, 39, 40, 43, 44, 45, 46, 47, 50, 53, 55, 56, 60, 62, 70, 74, 77, and 79.
- (23) Position wire 1603 (38) on terminal board TB2 (41) with washer (46), lockwasher (47), and nut (48).

7-11. WTEC III DASHBOARD CABLE ASSEMBLY REPLACEMENT/REPAIR (CONT)

d. Installation.

- (1) Deleted
- (2) Deleted
- (3) Deleted
- (4) Install circuit breaker CB68 (5) on PDP (2).

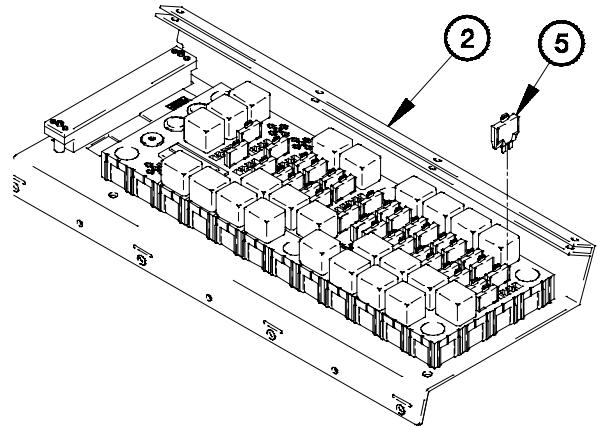

Xg11a01b

- (5) Install relay K15 (6) on PDP (2).

NOTE

Perform steps (6) and (7) on M1084/M1086/M1088 and M1089.

- (6) Install circuit breaker CB72 (7) on PDP (2).
- (7) Install relay K12 (8) on PDP (2).

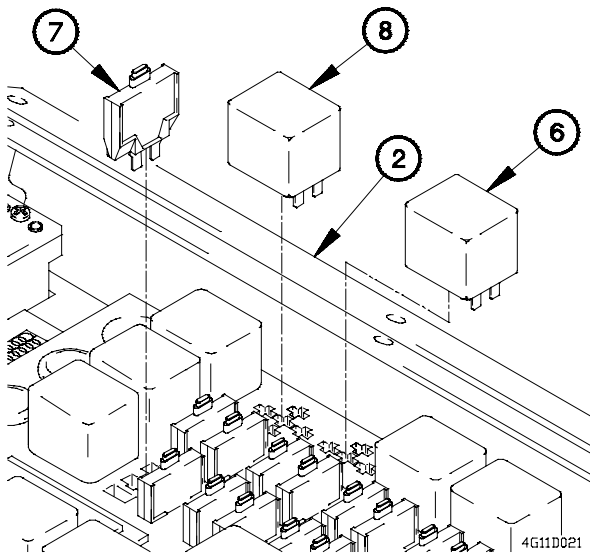

NOTE

- Step (8) requires the aid of an assistant.
- Install plastic cable ties as required.

- (8) Position WTEC III dashboard cable assembly (9) in dashboard (10).
- (9) Install two washers (11), screw (12), terminal lug TL57 (13), terminal lug TL190 (14), lockwasher (15), and nut (16) on dashboard (10).

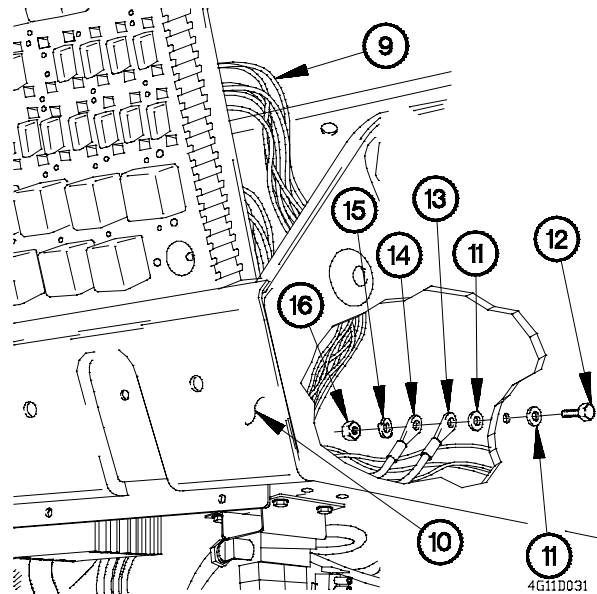

- (10) Install terminal lug TL14 (17) on terminal board TB2 (18) position 12.
- (11) Install terminal lug TL87 (19) on terminal board TB2 (18) position 6.
- (12) Remove two nuts (20), lockwashers (21), two washers (22), cover (23), and two washers (22) from terminal board TB1 (24).
- (13) Install terminal lug TL75 (25) on terminal board TB1 (24) position 2.
- (14) Install terminal lug TL71 (26) on terminal board TB2 (18) position 2.

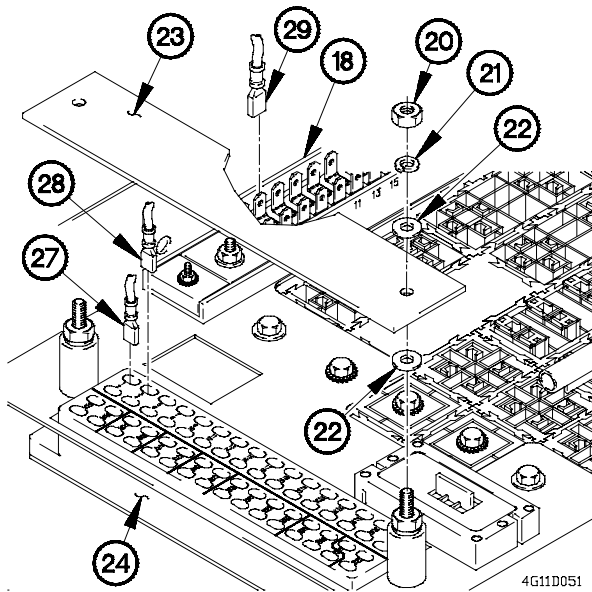
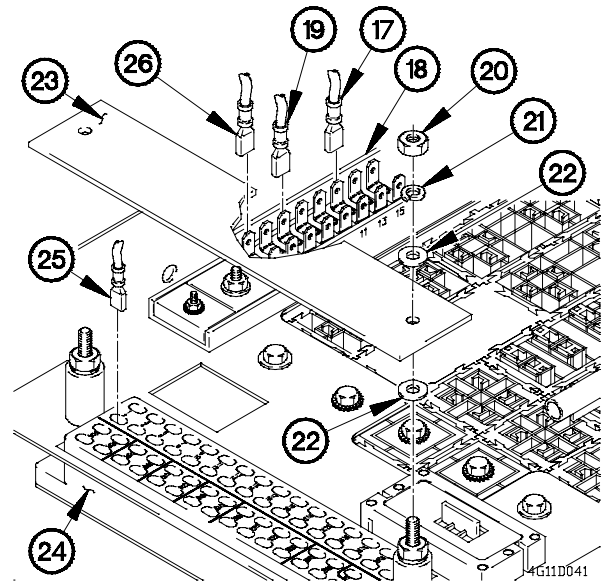

- (15) Install terminal lug TL73 (27) on terminal board TB1 (24) position 1.
- (16) Install terminal lug TL74 (28) on terminal board TB1 (24) position 3.
- (17) Install two washers (22) and cover (23) on terminal board TB1 (24) with two washers (22), lockwashers (21), and nuts (20).
- (18) Install terminal lug TL86 (29) on terminal board TB2 (18) position 4.

- (19) Remove screw (30), lockwasher (31), and four terminal lugs (32) from PDP (2).
- (20) Position four terminal lugs (32) and terminal lug TL42 (33) on PDP (2) with lockwasher (31), and screw (30).
- (21) Tighten screw (30) to 35-45 lb-in. (4-5 N-m).

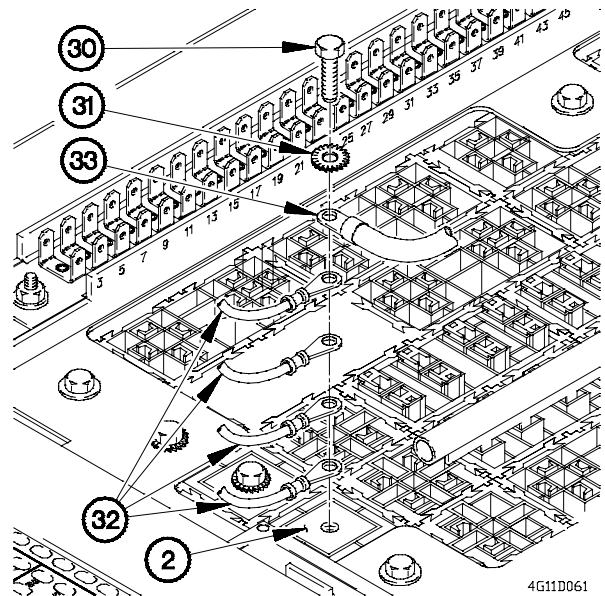

7-11. WTEC III DASHBOARD CABLE ASSEMBLY REPLACEMENT/REPAIR (CONT)

- (22) Remove screw (34), lockwasher (35), and four terminal lugs (36) from PDP (2).
- (23) Position four terminal lugs (36) and terminal lug TL41 (37) on PDP (2) with lockwasher (35) and screw (34).
- (24) Tighten screw (34) to 35-45 lb-in. (4-5 N·m).
- (25) Remove screw (38), lockwasher (39), and terminal lug (40) from PDP (2).
- (26) Position terminal lug (40) and terminal lug TL56 (41) on PDP (2) with lockwasher (39) and screw (38).
- (27) Tighten screw (38) to 35-45 lb-in. (4-5 N·m).

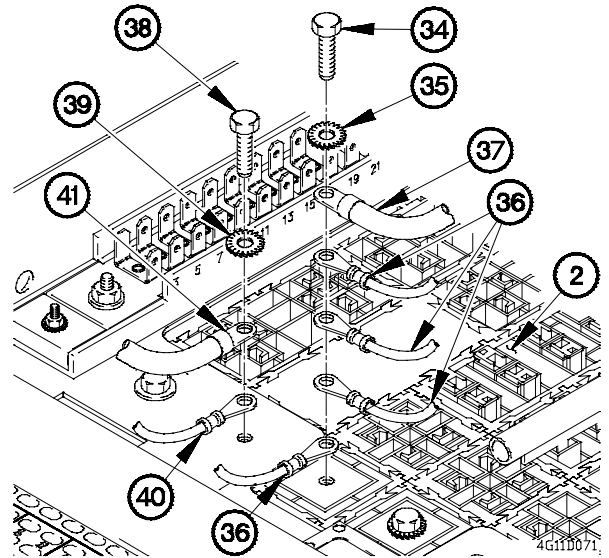

NOTE

Perform step (28) on M1088.

- (28) Install terminal lugs TL502 (42) and TL501 (43) on terminal studs (44 and 45) with two lockwashers (46) and nuts (47).

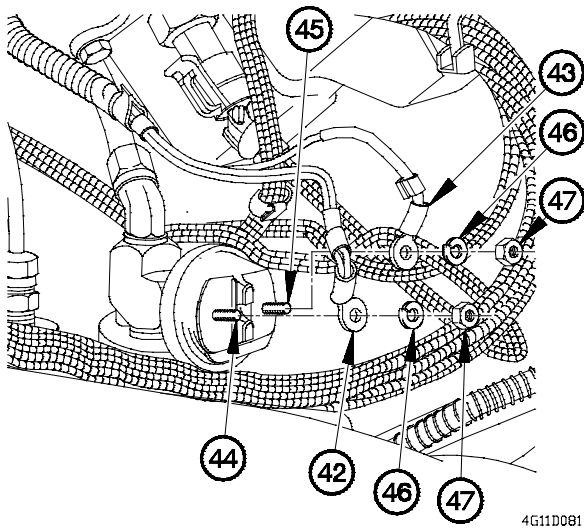

NOTE

Perform step (29) on vehicles equipped with cab radio.

- (29) Connect connector P78 (48) to connector J78 (49).

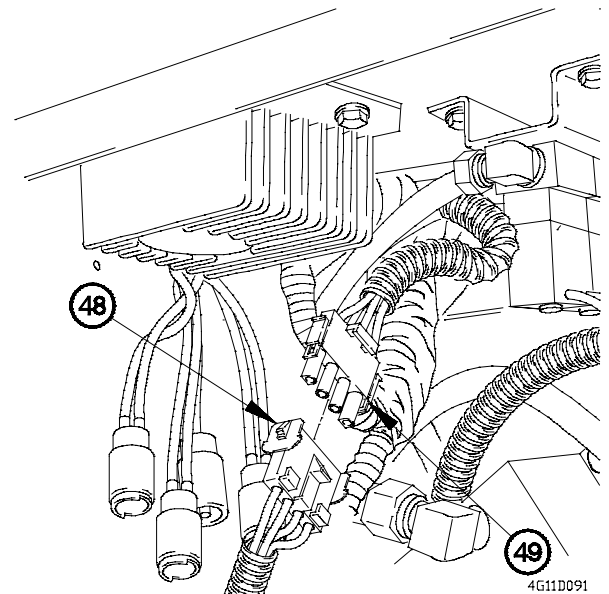

- (30) Connect connector P116 (50) to WTEC III transmission ECU (51).
- (31) Connect connector clamp (52) on connector P116 (50).
- (32) Connect connector P115 (53) to WTEC III transmission ECU (51).
- (33) Connect connector clamp (54) on connector P115 (53).

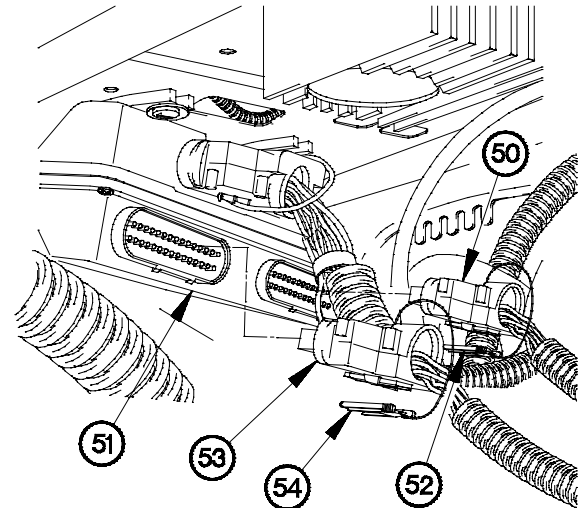

4G11D101

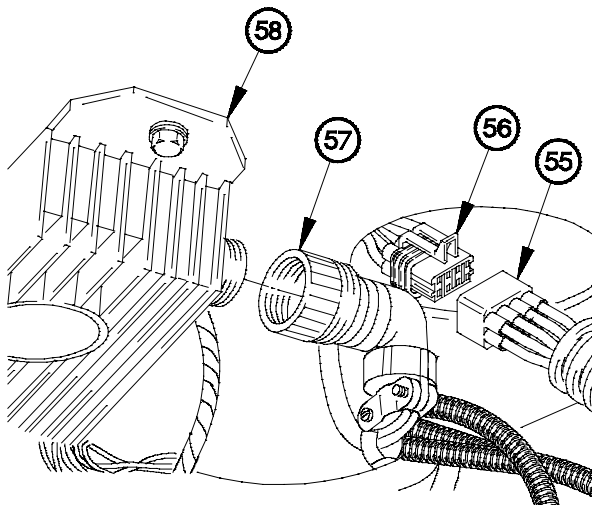

4G11D111

- (34) Connect connector P111 (55) to connector J111 (56).
- (35) Connect connector PX20 (57) to flasher module (58).

- (36) Connect connector J99 (59) to chemical alarm kit cable connector P99 (60).
- (37) Connect connector P65 (61) to warning light cable connector J65 (62).
- (38) Connect differential lock solenoid connector (63) to connector PX50 (64).
- (39) Connect fan solenoid connector (65) to connector PX34 (66).

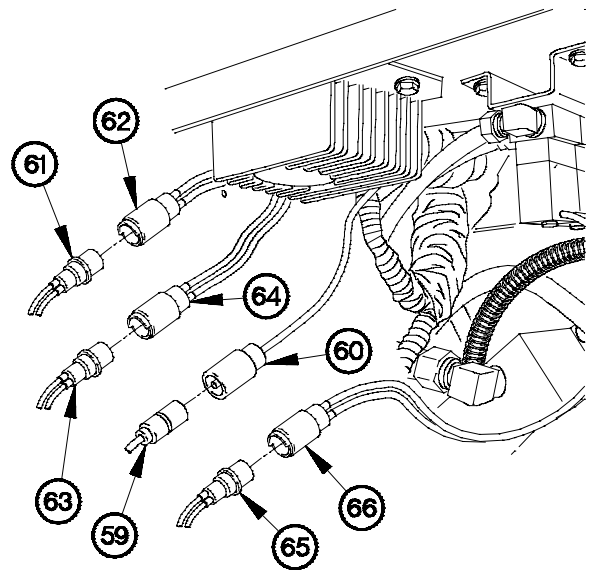

4G11D121

7-11. WTEC III DASHBOARD CABLE ASSEMBLY REPLACEMENT/REPAIR (CONT)

- (40) Connect connector P51 (67) to connector J51 (68).
- (41) Connect connector P27 (69) to connector J27 (70).

NOTE

Perform step (42) on vehicles not equipped with auxiliary panel.

- (42) Connect connector P912A (71) to connector J912 (72).

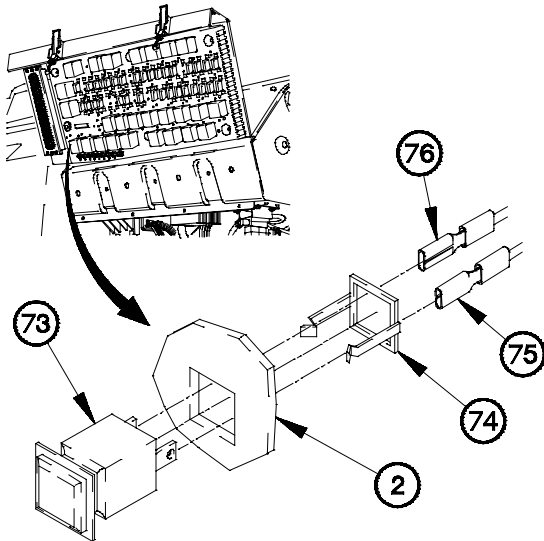
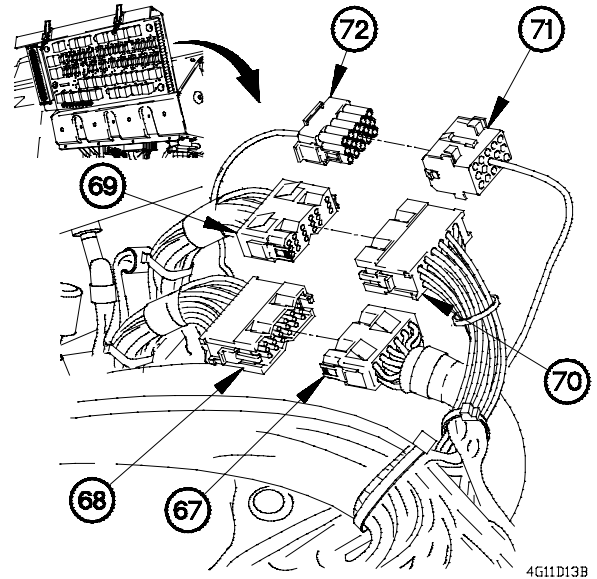

- (43) Position start inhibit pushbutton switch (73) in PDP (2).
- (44) Install spring clip (74) on start inhibit pushbutton switch (73).
- (45) Connect terminal lugs TL159 (75) and TL158 (76) to start inhibit pushbutton switch (73).

- (46) Install windshield wiper ECU (77) on PDP (2).

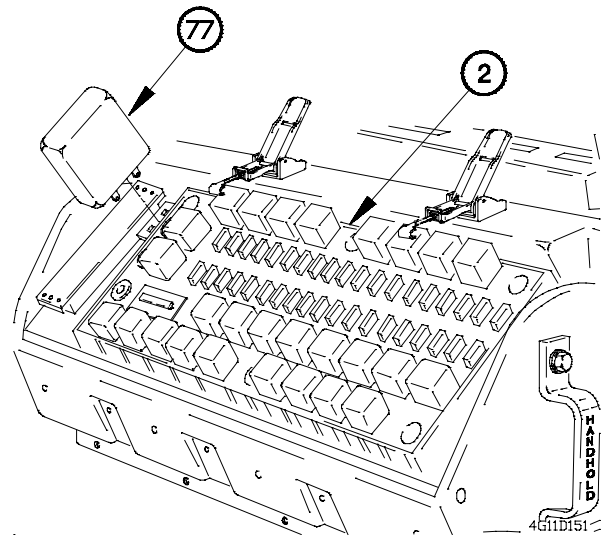

NOTE

Perform steps (47) and (48) on vehicles equipped with auxiliary panel.

(47) Connect connector P913 (78) to connector J913 (79).

(48) Connect connector P912 (80) to connector J912 (72).

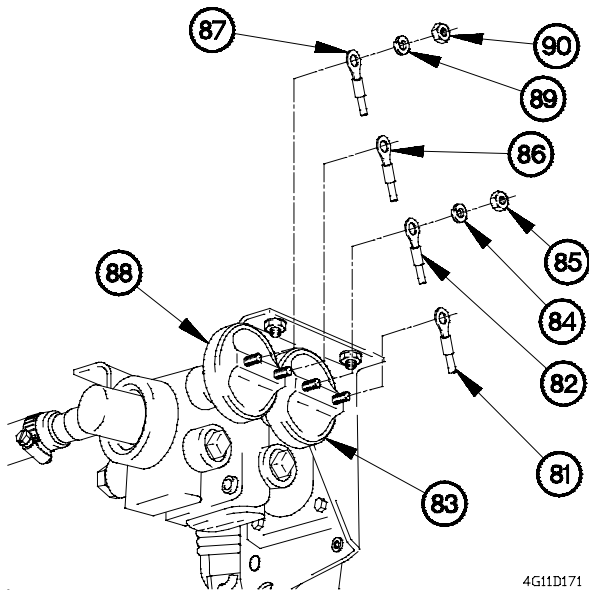
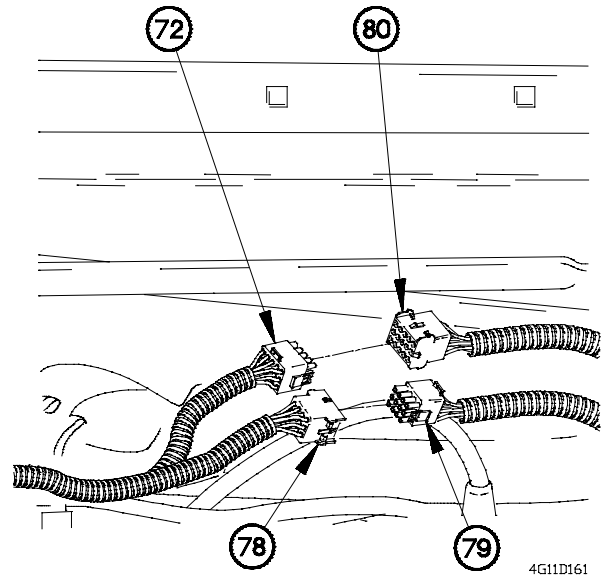

(49) Install terminal lugs TL155 (81) and TL154 (82) on front stoplight switch (83) with two lockwashers (84) and nuts (85).

(50) Install terminal lugs TL152 (86) and TL153 (87) on rear stoplight switch (88) with two lockwashers (89) and nuts (90).

(51) Install terminal lug TL156 (91) on rear brake air pressure transmitter terminal G (92) with lockwasher (93) and nut (94).

(52) Install terminal lug TL150 (95) on rear brake air pressure transmitter terminal WK (96) with lockwasher (97) and nut (98).

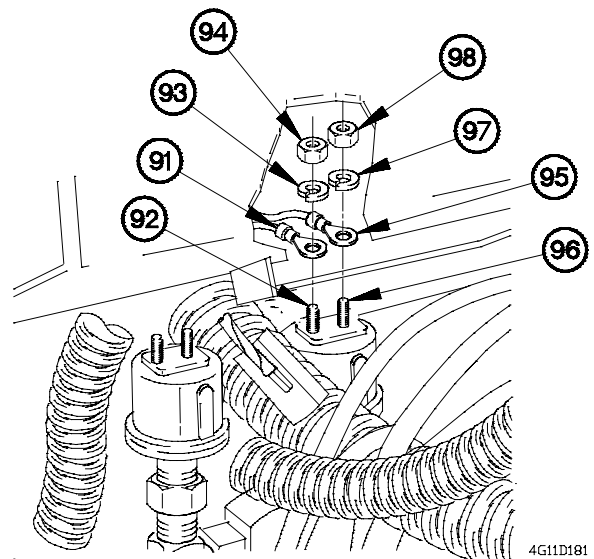

7-11. WTEC III DASHBOARD CABLE ASSEMBLY REPLACEMENT/REPAIR (CONT)

- (53) Install terminal lug TL157 (99) on front brake air pressure transmitter terminal G (100) with lockwasher (101) and nut (102).
- (54) Install terminal lug TL151 (103) on front brake air pressure transmitter terminal WK (104) with lockwasher (105) and nut (106).

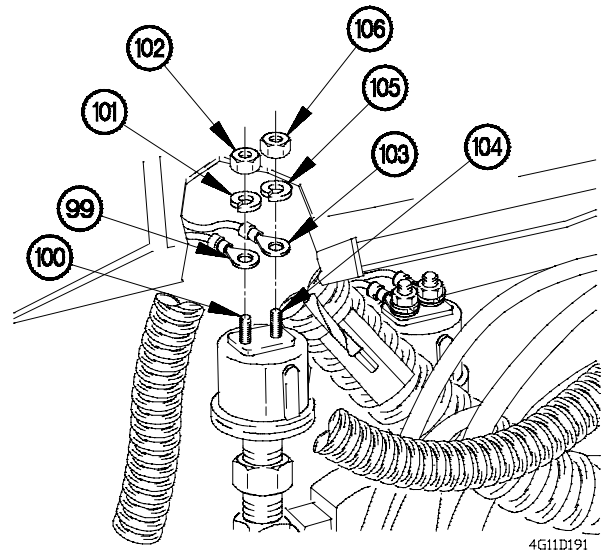

4G11D191

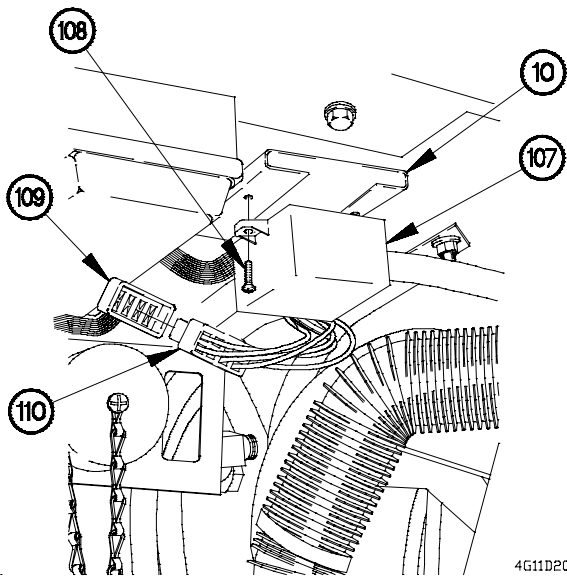

4G11D201

- (55) Install frequency ECU (107) on left side dashboard (10) with two screws (108).
- (56) Connect connector PX26 (109) to frequency ECU connector (110).

- (57) Position clamp (111) on WTEC III dashboard cable assembly (9).
- (58) Position clamp (111) on dashboard (10) with washer (112) and screw (113).
- (59) Tighten screw (113) to 35-45 lb-in. (4-5 N-m).

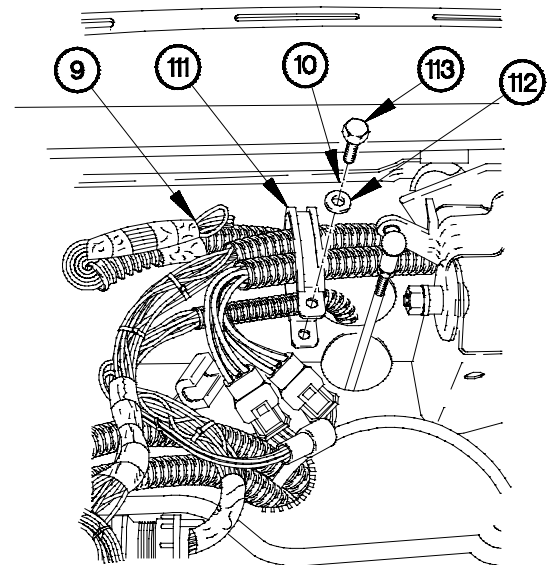

4G11D211

(60) Connect connector J31 (114) to connector P31 (115).

(61) Connect connector J43 (116) to connector P43 (117).

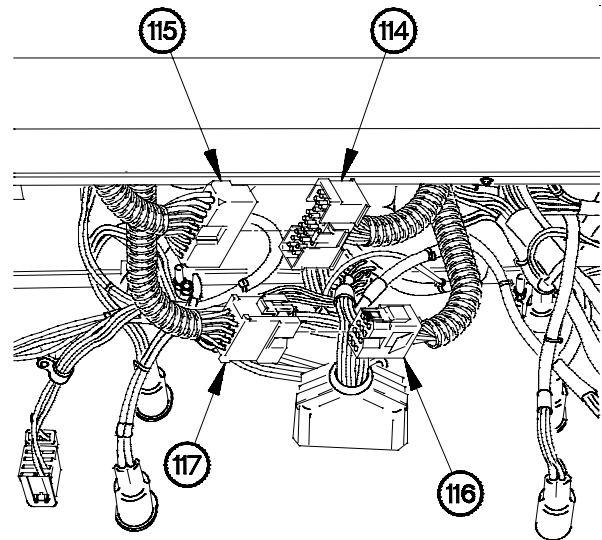

4G11D221

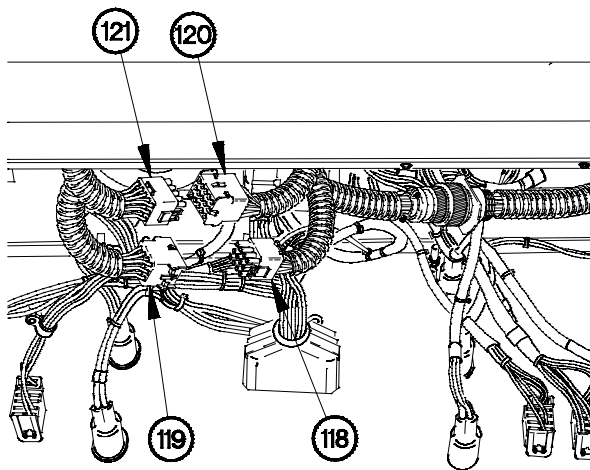

4G11D231

(62) Connect steering column switch connector P18 (118) to connector J18 (119).

(63) Connect steering column switch connector J19 (120) to connector P19 (121).

e. Follow-On Maintenance.

- (1) Install windshield wiper motor (para 18-4).
- (2) Install personnel heater (para 18-9).
- (3) Install instrument panel assembly (para 7-15).
- (4) Start engine (TM 9-2320-366-10-1).
- (5) Check instruments operation (TM 9-2320-366-10-1).
- (6) Shut down engine (TM 9-2320-366-10-1).

End of Task.

7-12. DIMMER SWITCH REPLACEMENT

This task covers:

- a. Removal
- b. Installation
- c. Follow-On Maintenance

INITIAL SETUP

Equipment Conditions

Instrument panel assembly removed for access (para 7-15).

Tools and Special Tools

Tool Kit, Genl Mech (Item 46, Appendix C)

a. Removal.

- (1) Disconnect connector clamp (1) from dimmer switch connector (2).
- (2) Disconnect connector PX24 (3) from dimmer switch connector (2).
- (3) Loosen screw (4) on dimmer switch knob (5).
- (4) Remove dimmer switch knob (5) from dimmer switch (6).
- (5) Remove nut (7), washer (8), and dimmer switch (6) from instrument panel assembly (9).

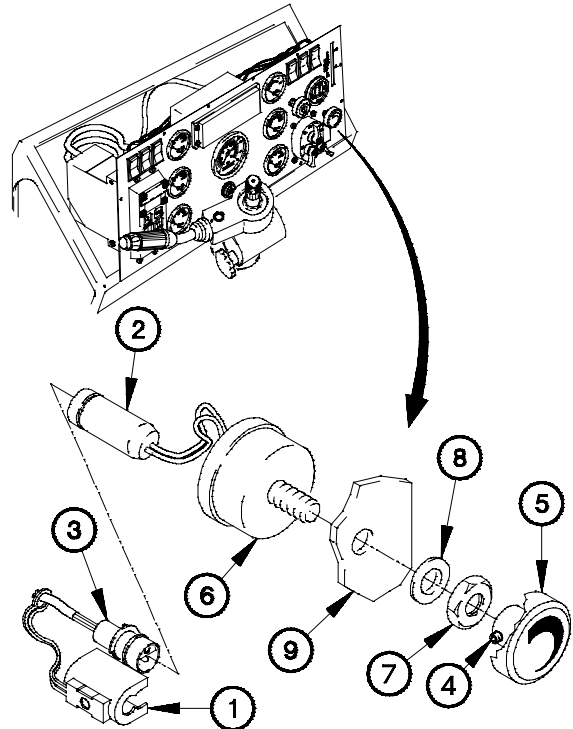

XG12X011

b. Installation.

- (1) Install dimmer switch (6) in instrument panel assembly (9) with washer (8) and nut (7).
- (2) Install dimmer switch knob (5) on dimmer switch (6).
- (3) Tighten screw (4) on dimmer switch knob (5).
- (4) Connect connector PX24 (3) to dimmer switch connector (2).
- (5) Connect connector clamp (1) on dimmer switch connector (2).

c. Follow-On Maintenance.

- (1) Install instrument panel assembly (para 7-15).
- (2) Check dimmer switch operation (TM 9-2320-366-10-1).

End of Task.

7-13. WTEC II TRANSMISSION ECU PUSHBUTTON SHIFT SELECTOR (TEPSS) DIMMER MODULE REPLACEMENT

This task covers:

- a. Removal
- b. Installation
- c. Follow-On Maintenance

INITIAL SETUP

Equipment Conditions

- Batteries disconnected (para 7-57).
- PDP cover removed (para 16-2).

Materials/Parts

- Ties, Cable, Plastic (Item 69, Appendix D)

Tools and Special Tools

- Tool Kit, Genl Mech (Item 46, Appendix C)

a. Removal.

- (1) Remove three screws (1) and washers (2) from PDP (3).
- (2) Remove three screws (4) from PDP (3).
- (3) Lift PDP (3) out to gain access.

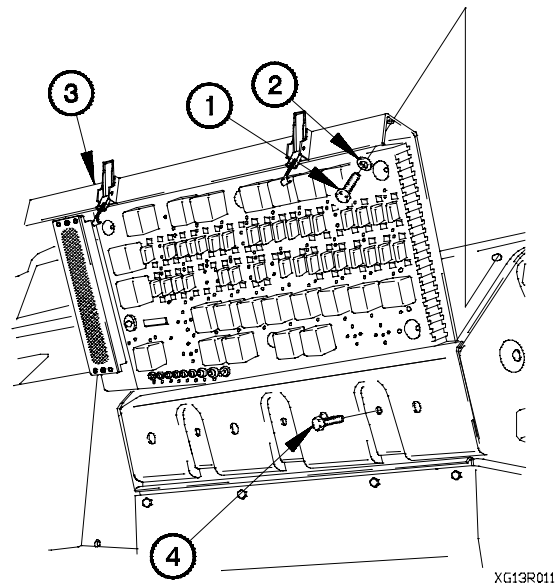

NOTE

Remove plastic cable ties as required.

- (4) Disconnect connector J7 (5) from WTEC II TEPSS dimmer module connector (6).

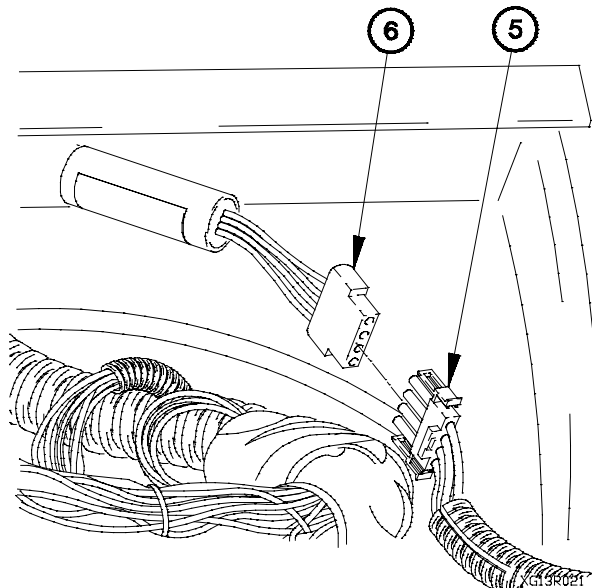

7-13. WTEC II TRANSMISSION ECU PUSHBUTTON SHIFT SELECTOR (TEPSS) DIMMER MODULE REPLACEMENT (CONT)

b. Installation.

NOTE

Install plastic cable ties as required.

- (1) Connect connector J7 (1) to WTEC II TEPSS dimmer module connector (2).

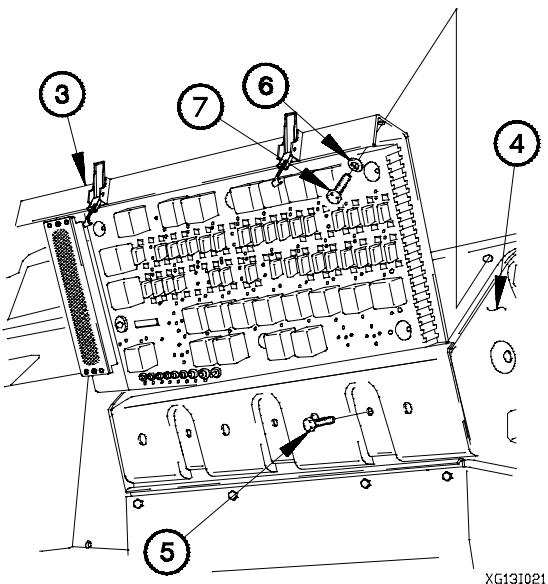
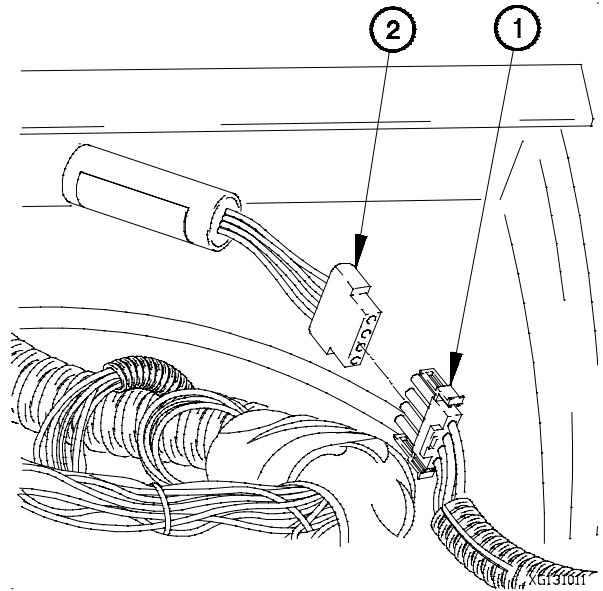

- (2) Install PDP (3) on dashboard (4) with three screws (5).
- (3) Install three washers (6) and screws (7) in PDP (3).

c. Follow-On Maintenance.

- (1) Install PDP cover (para 16-2).
- (2) Connect batteries (para 7-57).

End of Task.

7-14. ELECTRICAL GAGES REPLACEMENT

This task covers:

- a. Removal
- b. Installation
- c. Follow-On Maintenance

INITIAL SETUP

Equipment Conditions

Instrument panel assembly removed for access (para 7-15).

Tools and Special Tools

Tool Kit, Genl Mech (Item 46, Appendix C)
Wrench, Torque, 0-75 lb-in. (Item 90, Appendix B)

Materials/Parts

Ties, Cable, Plastic (Item 69, Appendix D)
Nut, Self-Locking (2) (Item 133, Appendix G)

a. Removal.

NOTE

All electrical gages are removed the same way. Speedometer shown.

- (1) Disconnect connector clamp (1) from speedometer connector (2).

NOTE

Remove plastic cable ties as required.

- (2) Disconnect connector PX8 (3) from speedometer connector (2).

NOTE

Note position of speedometer prior to removal.

- (3) Remove two protective caps (4), self-locking nuts (5), retaining ring (6), and speedometer (7) from instrument panel assembly (8). Discard self-locking nuts.

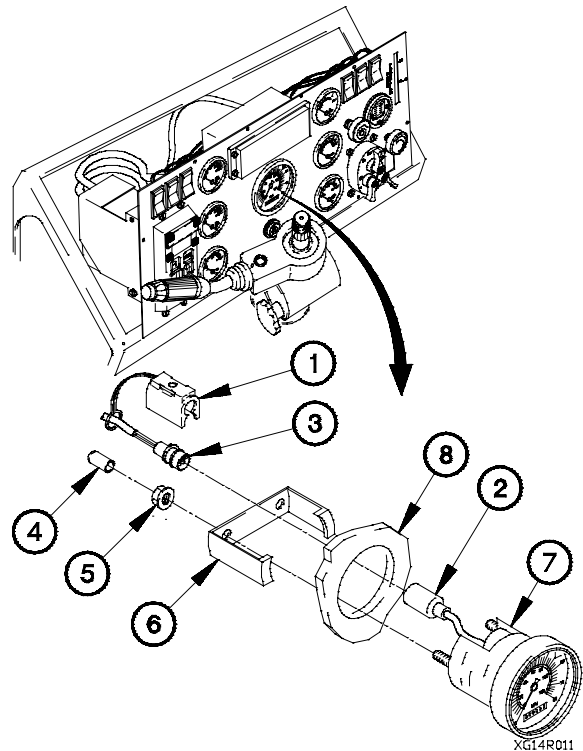

XG14R011

7-14. ELECTRICAL GAGES REPLACEMENT (CONT)

b. Installation.

CAUTION

Ensure dipswitch settings are correct. Failure to comply may result in inaccurate speedometer readings.

NOTE

Perform steps (1) through (3) on speedometer.

- (1) Remove cover (1) from speedometer (2).
- (2) Set dipswitches 3,6,7, and 9 in the up position.
- (3) Set dipswitches 1,2,4,5,8, and 10 in the bottom position.

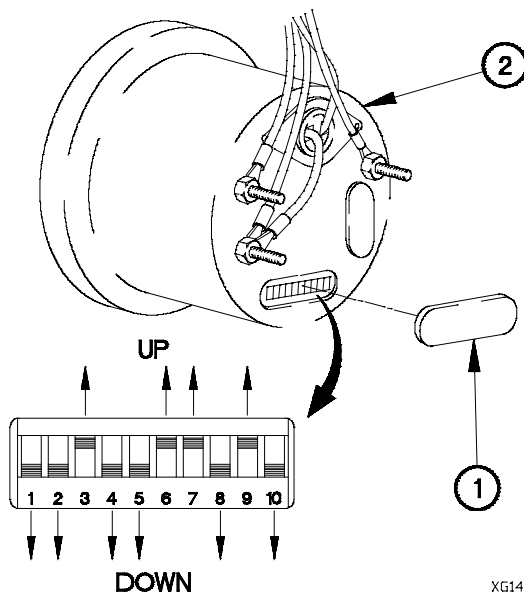

XG14101B

NOTE

Note position of speedometer prior to installation.

- (4) Position speedometer (2) in instrument panel assembly (3) with retaining ring (4) and two self-locking nuts (5).
- (5) Tighten two self-locking nuts (5) to 9 lb-in. (1 N·m).
- (6) Install two protective caps (6) on speedometer (2).

NOTE

Install plastic cable ties as required.

- (7) Connect connector PX8 (7) on speedometer connector (8).
- (8) Connect connector clamp (9) on speedometer connector (8).

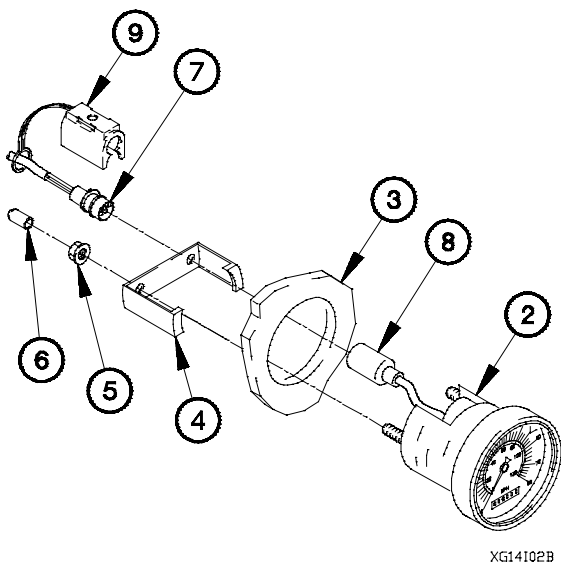

XG14102B

c. Follow-On Maintenance.

- (1) Install instrument panel assembly (para 7-15).
- (2) Check gage(s) operation (TM 9-2320-366-10-1).

End of Task.

7-15. INSTRUMENT PANEL ASSEMBLY REPLACEMENT/REPAIR

This task covers:

- | | |
|----------------|--------------------------|
| a. Removal | d. Installation |
| b. Disassembly | e. Follow-On Maintenance |
| c. Assembly | |

INITIAL SETUP

Equipment Conditions

- Batteries disconnected (para 7-57).
- Steering wheel removed (para 13-2).

Materials/Parts

- Dispenser, Pressure Sensitive Adhesive Tape (Item 20, Appendix D)

Tools and Special Tools

- Tool Kit, Genl Mech (Item 46 , Appendix C)
- Wrench, Torque, 0-75 lb-in. (Item 90, Appendix B)
- Wrench, Torque, 0-200 lb-in. (Item 59, Appendix C)
- Socket Set, Socket Wrench (Item 34, Appendix C)

a. Removal.

NOTE

Perform steps (1) through (4) if removing instrument panel assembly for access.

- (1) Loosen screw (1) in HAND THROTTLE knob (2).
- (2) Remove HAND THROTTLE knob (2) from HAND THROTTLE lever (3).
- (3) Remove 16 screws (4) and washers (5) from instrument panel assembly (6).
- (4) Lift instrument panel assembly (6) outward to gain access.

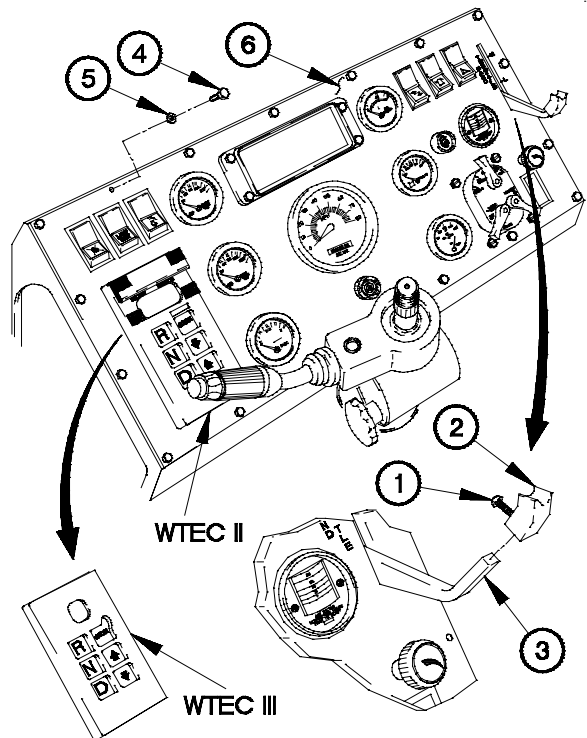

XG15A011

7-15. INSTRUMENT PANEL ASSEMBLY REPLACEMENT/REPAIR (CONT)

NOTE

Remove plastic cable ties as required.

- (5) Disconnect connector PX7 (7) from lighted indicator display (8).

NOTE

All electrical gages are disconnected the same way. OIL PRESS gage shown. Refer to **Table 7-1.2 Electrical Gages Connectors** for correct combinations of gages and connectors.

Table 7-1.2 Electrical Gages Connectors

Electrical Gage	Connector Number
FRONT BRAKE AIR	PX4
REAR BRAKE AIR	PX5
FUEL	PX9
Speedometer	PX8
OIL PRESS	PX6
VOLTS	PX10
WATER TEMP	PX11

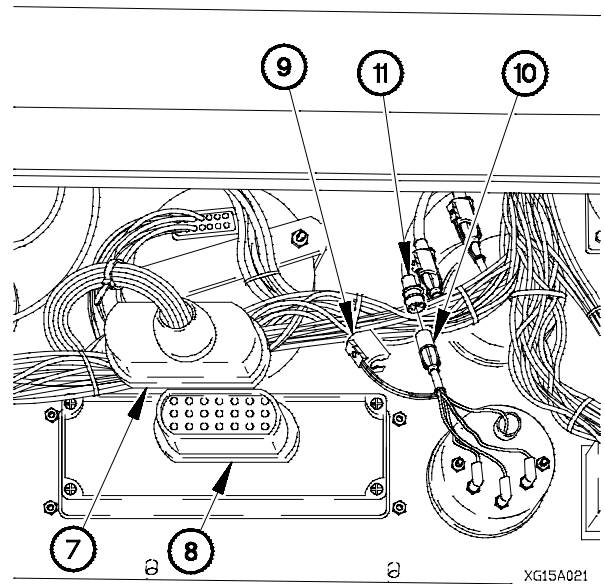

- (6) Disconnect connector clamp (9) from OIL PRESS gage connector (10).
- (7) Disconnect connector (11) from OIL PRESS gage connector (10).
- (8) Perform steps (6) and (7) on remaining electrical gages.

NOTE

- Vehicle serial numbers 0002 through 0017, 0019 through 0025, 0027 through 0031, 0033 through 0038, 0040 and 0041, 0043 through 0053, 0055 through 0089, 0091 through 0254, 0256 through 0258, 0260, 0261, 0263 through 2400, and 2402 through 3091 are not equipped with LAMP TEST switch.
- Vehicle serial numbers 0001 through 1477 were originally equipped with dashboard cable assemblies containing two unused connectors for LAMP TEST switch. Vehicle serial numbers 1478 through 3091 were originally equipped with dashboard cable assemblies without connectors for LAMP TEST switch.
- All rocker switches are disconnected the same way. Hazard lights switch shown. Refer to **Table 7-2. Rocker Switch Connectors** for correct combinations of rocker switches and connectors.

Table 7-2. Rocker Switch Connectors

Switch Name	Connector Number
Radiator Fan Off	PX1 and PX1A
LAMP TEST	PX2 and PX2A
Ether Start	PX13 and PX13A
Master Power	PX17 and PX17A
Warning Light	PX12 and PX12A
Hazard Lights	PX14 and PX14A

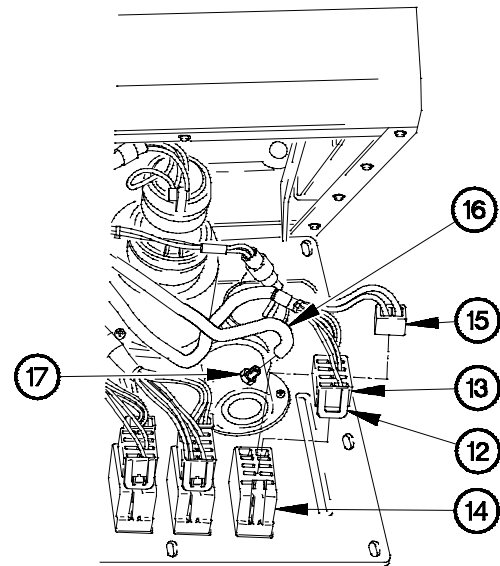

Xg15a031

- (9) Lift tab (12) on connector (13).
- (10) Disconnect connector (13) from hazard lights switch (14).
- (11) Disconnect connector (15) from hazard lights switch (14).
- (12) Perform steps (9) through (11) on remaining rocker switches.
- (13) Disconnect vacuum hose (16) from AIR FILTER RESTRICTION GAUGE (17).

7-15. INSTRUMENT PANEL ASSEMBLY REPLACEMENT/REPAIR (CONT)

NOTE

Perform step (14) on M1084, M1086, M1088, M1089, M1092, and M1096.

- (14) Remove two screws (18) and terminal lugs TL160 (19) and TL161 (20) from audible alarm (21).

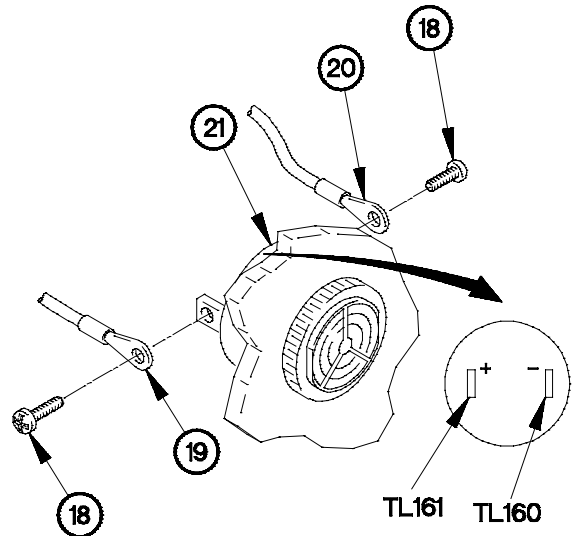
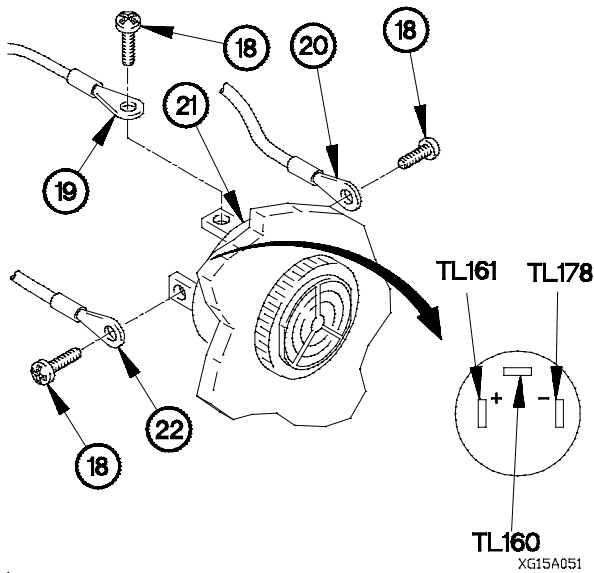

NOTE

Perform step (15) on M1083, M1085, M1090, M1093, and M1094.

- (15) Remove three screws (18) and terminal lugs TL160 (19), TL161 (20), and TL178 (22) from audible alarm (21).

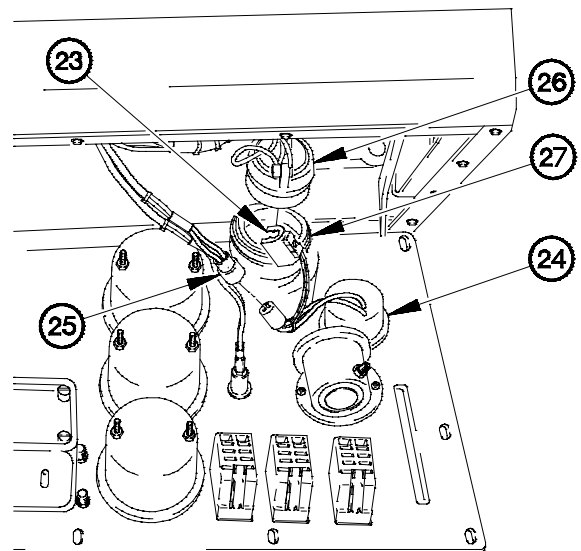

- (16) Remove connector clamp (23) from dimmer switch (24).
- (17) Disconnect connector PX24 (25) from dimmer switch (24).
- (18) Disconnect connector PX15 (26) from main light switch (27).

- (19) Disconnect terminal lugs TL162 (28) and TL163 (29) from starter pushbutton switch (30).

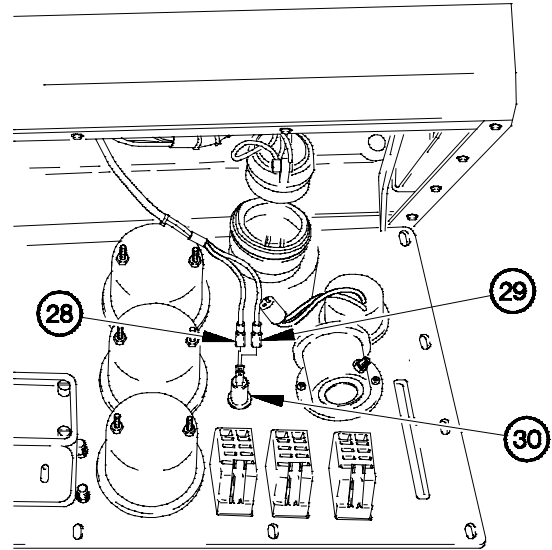

Xg15a071

NOTE

Perform steps (20) through (22) on vehicles equipped with WTEC II transmission controls.

- (20) Disconnect connector J115 (31) from WTEC II TEPSS (32).
- (21) Disconnect connector J114 (33) from WTEC II TEPSS (32).
- (22) Remove screw (34), washer (35) and terminal lug (36) from instrument panel assembly (6).

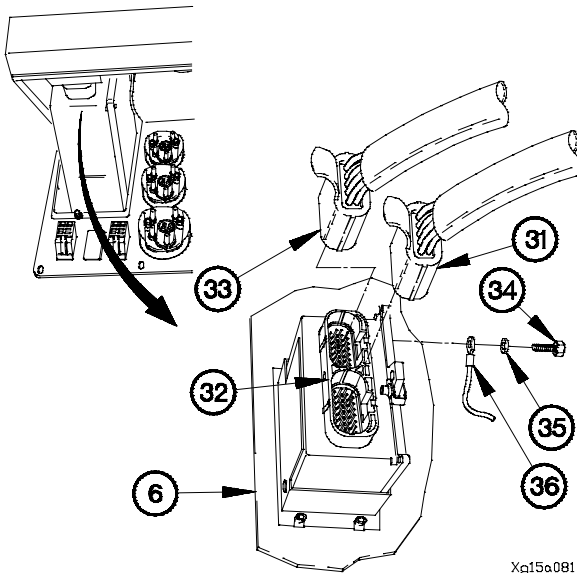

Xg15a081

NOTE

Perform step (23) on vehicles equipped with WTEC III transmission controls.

- (23) Disconnect connector PX33 (37) from WTEC III TPSS (38).
- (24) Remove instrument panel assembly (6) from dashboard (39).

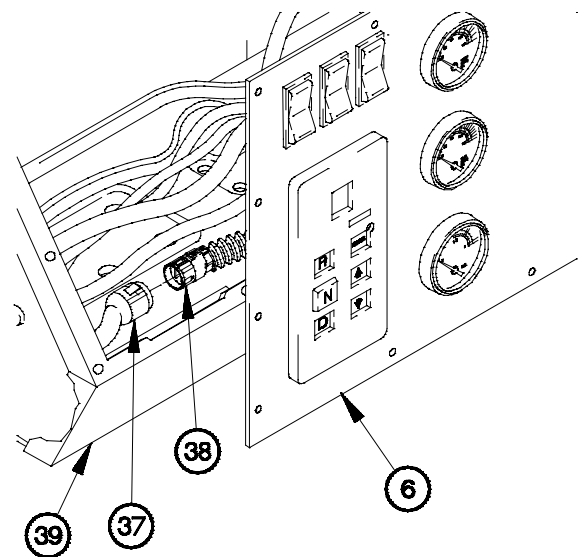

XG15A091

7-15. INSTRUMENT PANEL ASSEMBLY REPLACEMENT/REPAIR (CONT)

b. Disassembly.

NOTE

- All rocker switches are removed the same way. Radiator fan off switch shown.
- Note position of rocker switches prior to removal.

- (1) Push in two tabs (1) on radiator fan off switch (2).
- (2) Remove radiator fan off switch (2) from instrument panel (3).
- (3) Perform steps (1) and (2) on remaining rocker switches.

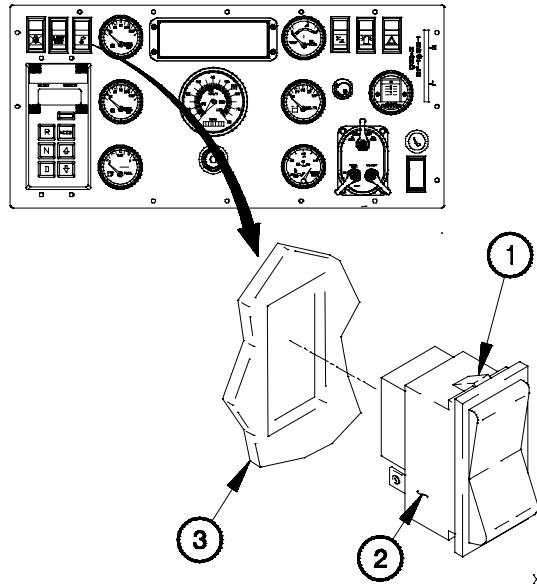

XG15B011

NOTE

- All electrical gages are removed the same way. FUEL gage shown.
- Note position of electrical gages prior to removal.

- (4) Remove two protective caps (4), self-locking nuts (5), retaining ring (6), and FUEL gage (7) from instrument panel (3). Discard self-locking nuts.
- (5) Perform step (4) on remaining electrical gages.

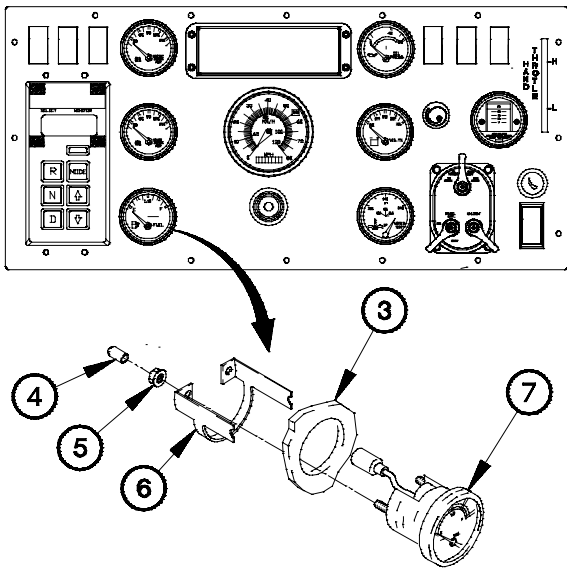

XG15B021

NOTE

Perform steps (6) and (7) on vehicles equipped with WTEC II transmission controls.

- (6) Remove two screws (8) and washers (9) from mounting bracket (10).
- (7) Remove four screws (11), mounting bracket (10), three clip nuts (12), and WTEC II TEPSS (13) from instrument panel (3).

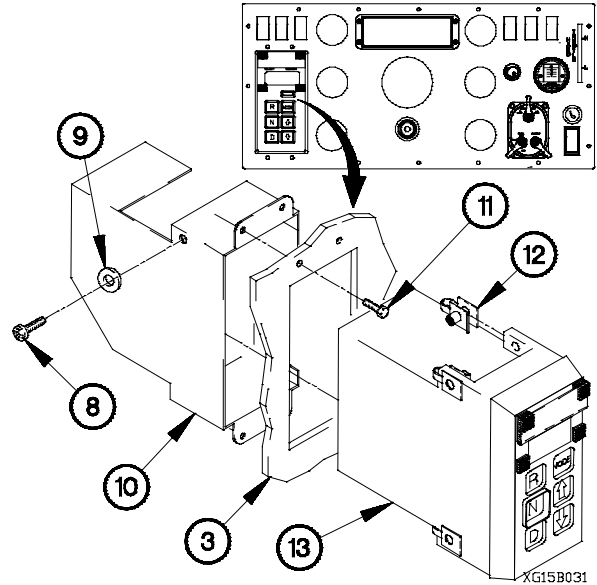

NOTE

Perform steps (8) and (9) on vehicles equipped with WTEC III transmission controls.

- (8) Remove two nuts (14) brackets (15) from WTEC III TPSS (16).
- (9) Remove WTEC III TPSS (16) from instrument panel (3).

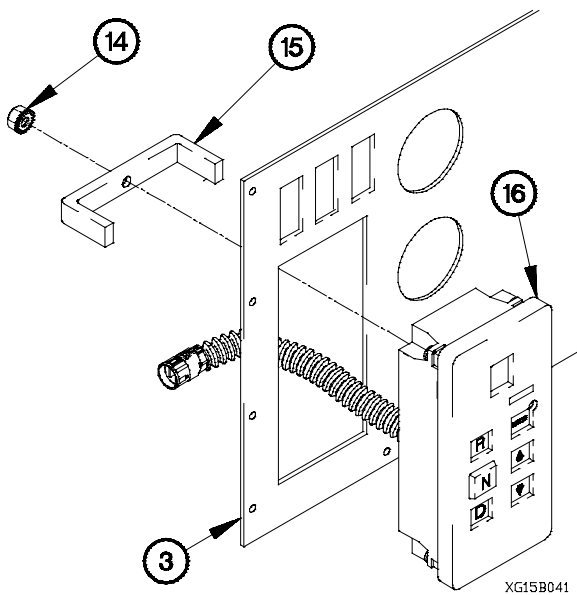

- (10) Remove four screws (17) and lighted indicator display (18) from instrument panel (3).

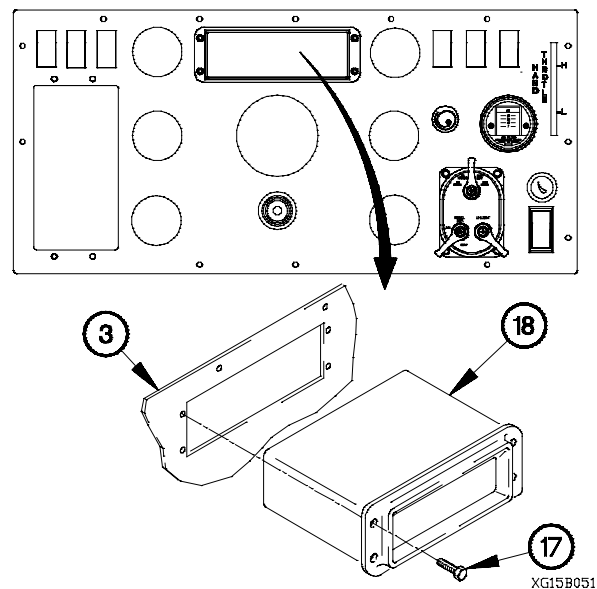

7-15. INSTRUMENT PANEL ASSEMBLY REPLACEMENT/REPAIR (CONT)

(11) Remove lock ring (19) and audible alarm (20) from instrument panel (3).

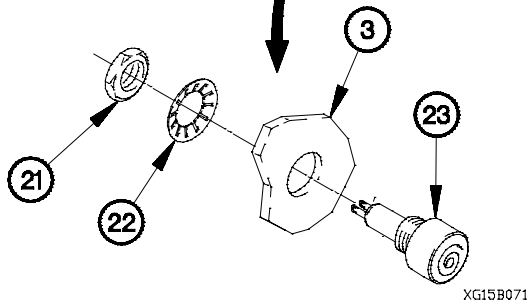
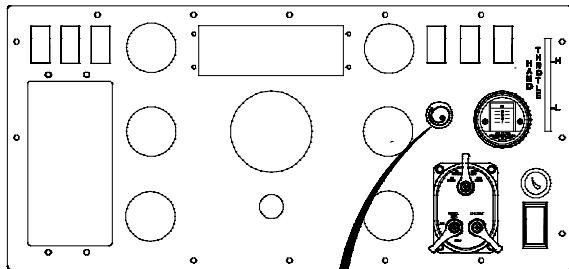
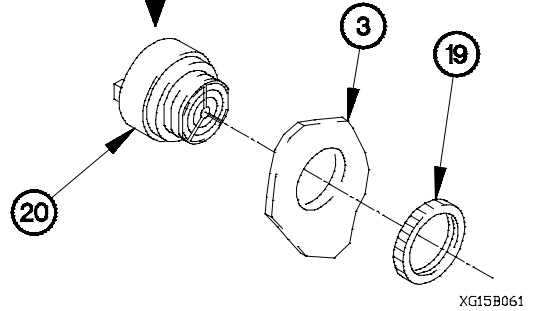
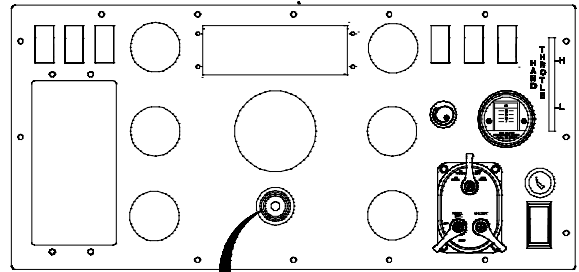

(12) Remove nut (21), washer (22), and starter pushbutton switch (23) from instrument panel (3).

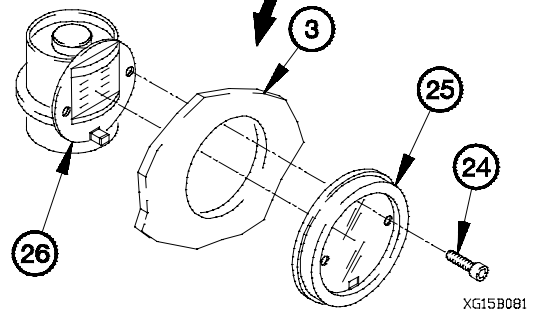
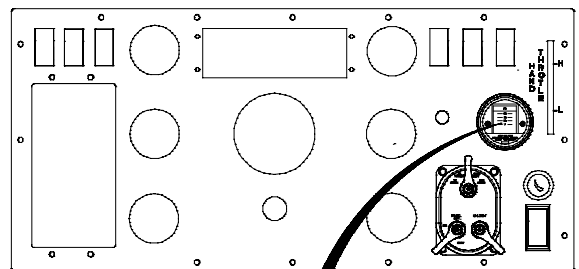

(13) Remove two screws (24), faceplate (25) and AIR FILTER RESTRICTION GAUGE (26) from instrument panel (3).

- (14) Loosen screw (27) on dimmer switch knob (28).
- (15) Remove dimmer switch knob (28) from dimmer switch (29).
- (16) Remove nut (30), washer (31), and dimmer switch (29) from instrument panel (3).

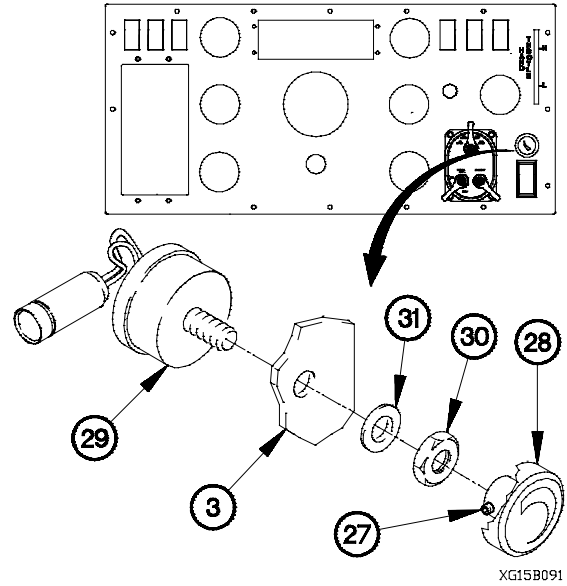

XG15B091

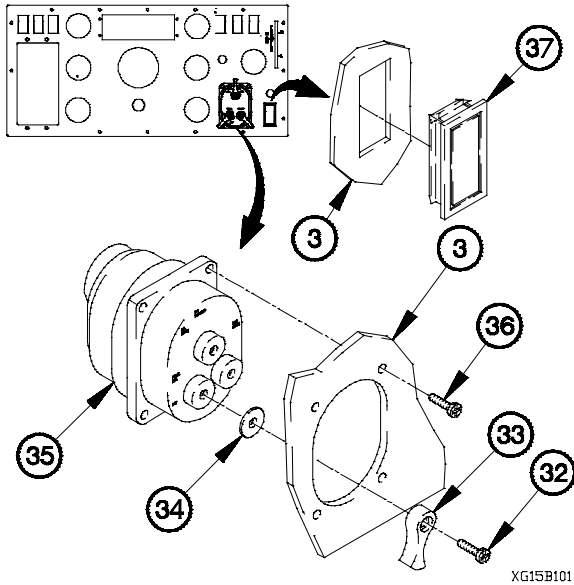

XG15B101

- (17) Remove three screws (32) from knobs (33).
- (18) Remove three knobs (33) and spacers (34) from main light switch (35).
- (19) Remove four screws (36) and main light switch (35) from instrument panel (3).
- (20) Remove electrical switch cover (37) from instrument panel (3).

c. Assembly.

- (1) Install electrical switch cover (1) in instrument panel (2).
- (2) Position main light switch (3) in instrument panel (2) with four screws (4).
- (3) Tighten four screws (4) to 9 lb-in. (1 N·m).
- (4) Install three spacers (5) and knobs (6) on main light switch (3).
- (5) Install three screws (7) in knobs (6).

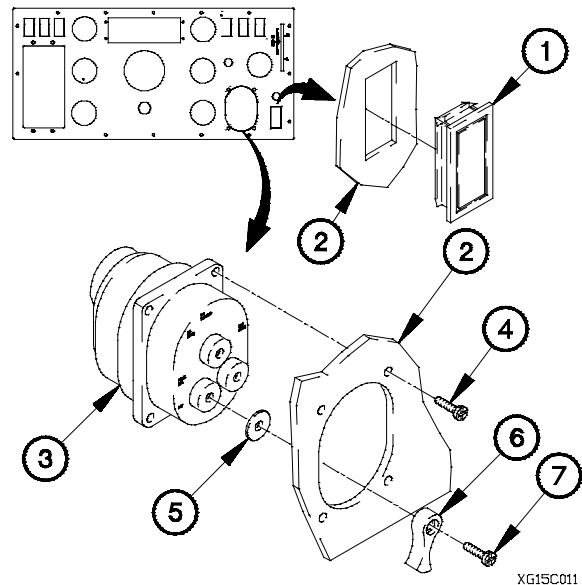

XG15C011

7-15. INSTRUMENT PANEL ASSEMBLY REPLACEMENT/REPAIR (CONT)

- (6) Position dimmer switch (8) in instrument panel (2) with washer (9) and nut (10).
- (7) Tighten nut (10) to 159-195 lb-in. (18-22 N-m).
- (8) Install dimmer switch knob (11) on dimmer switch (8).
- (9) Tighten screw (12) in dimmer switch knob (11).

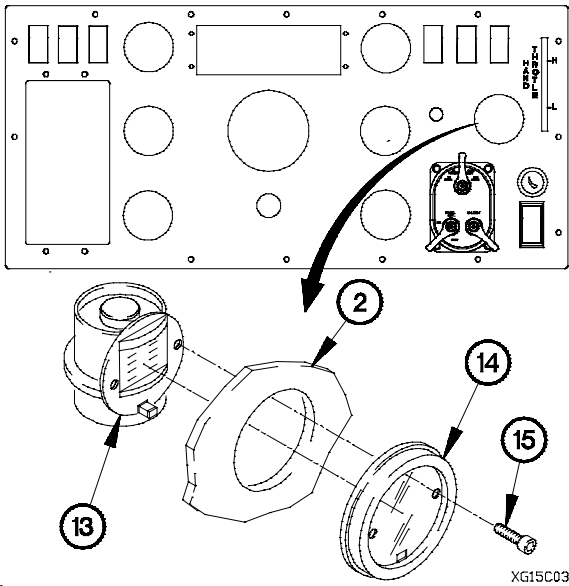
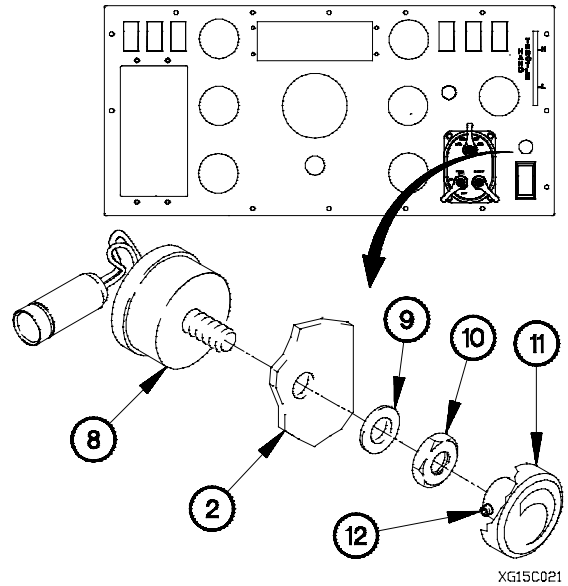

- (10) Install AIR FILTER RESTRICTION GAUGE (13) and faceplate (14) on instrument panel (2) with two screws (15).

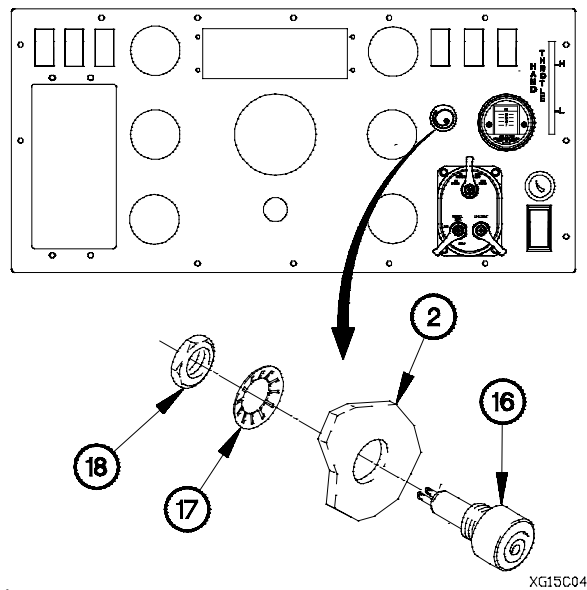

- (11) Position starter pushbutton switch (16) in instrument panel (2) with washer (17) and nut (18).
- (12) Tighten nut (18) to 57-70 lb-in. (6-8 N-m).

- (13) Install audible alarm (19) in instrument panel (2) with lock ring (20).

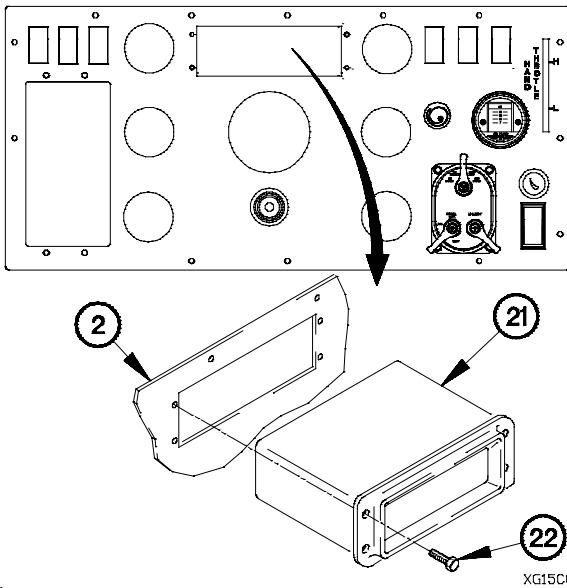
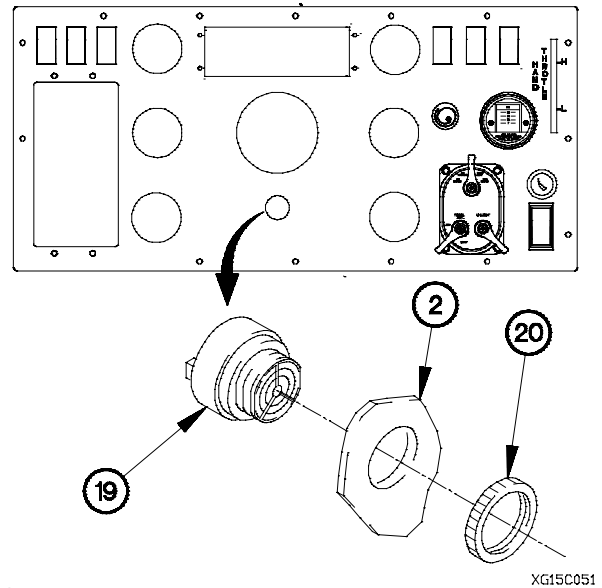

- (14) Position lighted indicator display (21) in instrument panel (2) with four screws (22).

- (15) Tighten four screws (22) to 9 lb-in. (1 N-m).

NOTE

Perform steps (16) through (19) on vehicles equipped with WTEC II transmission controls.

- (16) Position WTEC II TEPSS (23) in instrument panel (2) with three clip nuts (24), mounting bracket (25) and four screws (26).
- (17) Position two screws (27) and washers (28) in mounting bracket (25).
- (18) Tighten four screws (26) to 9 lb-in. (1 N-m).
- (19) Tighten two screws (27) to 27-35 lb-in. (3-4 N-m).

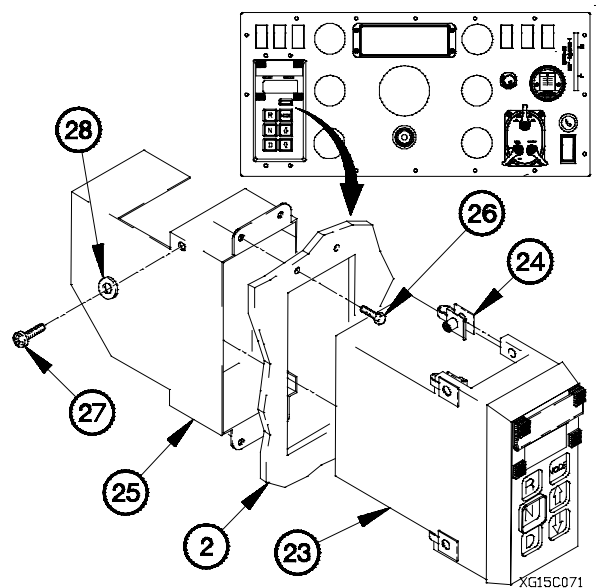

7-15. INSTRUMENT PANEL ASSEMBLY REPLACEMENT/REPAIR (CONT)

NOTE

Perform steps (20) through (22) on vehicles equipped with WTEC III transmission controls.

- (20) Install WTEC III TPSS (29) in instrument panel (2).
- (21) Position two brackets (30) on rear of WTEC III TPSS (29) with two nuts (31).
- (22) Tighten two nuts (31) to 11-13 lb-in. (1.3-1.5 N·m).

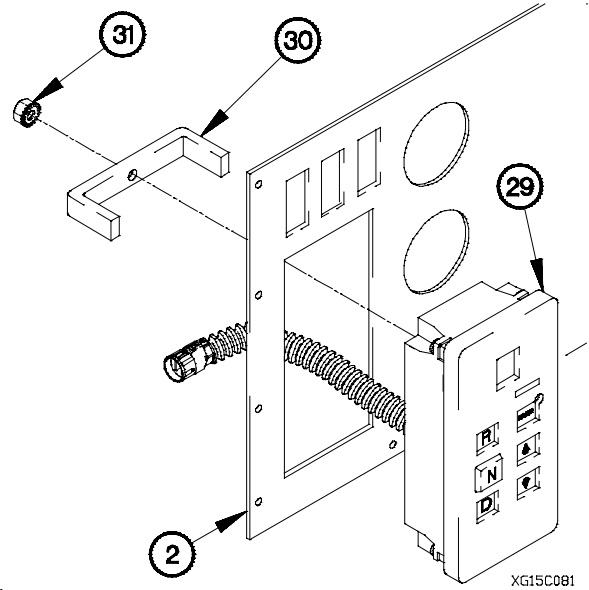

XG15C081

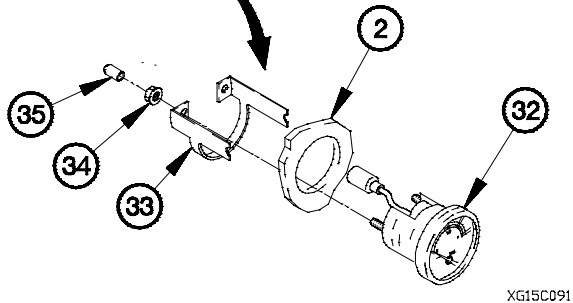
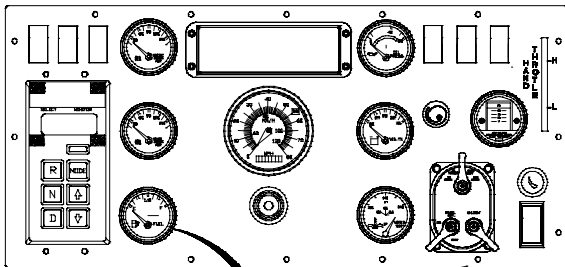

XG15C091

NOTE

All electrical gages are installed the same way. FUEL gage shown.

- (23) Position FUEL gage (32) in instrument panel (2) with mounting ring (33) and two self-locking nuts (34).
- (24) Tighten two self-locking nuts (34) to 9 lb-in. (1 N·m).
- (25) Install two protective caps (35) on FUEL gage (32).
- (26) Perform steps (23) through (25) on remaining gages.

NOTE

All rocker switches are installed the same way. Radiator fan off switch shown.

- (27) Install radiator fan off switch (36) in instrument panel (2).
- (28) Perform step (27) on remaining rocker switches.

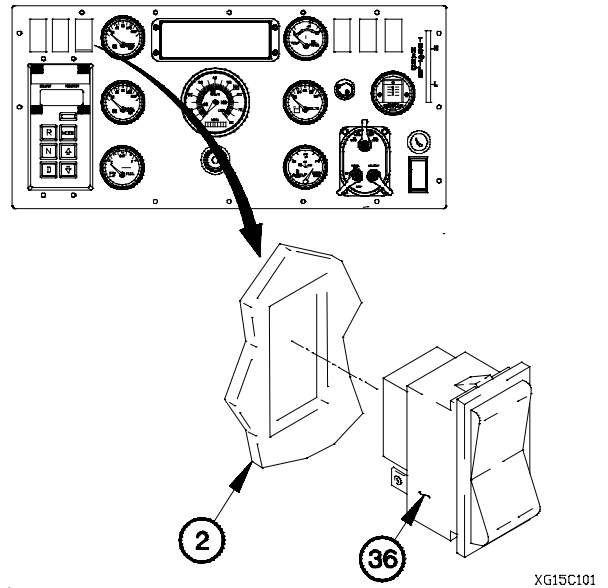

XG15C101

d. Installation.

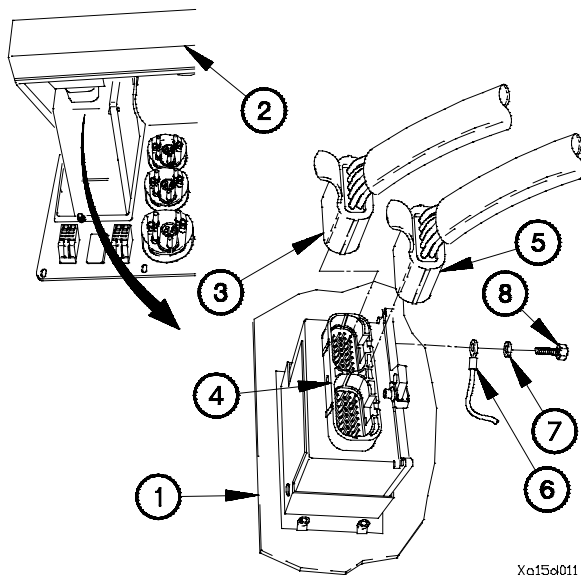

Xg15d011

- (1) Position instrument panel assembly (1) on dashboard (2).

NOTE

Perform steps (2) through (4) on vehicles equipped with WTEC II transmission controls.

- (2) Connect connector J114 (3) to WTEC II TEPSS (4).
- (3) Connect connector J115 (5) to WTEC II TEPSS (4).
- (4) Install terminal lug (6) on instrument panel assembly (1) with washer (7) and screw (8).

7-15. INSTRUMENT PANEL ASSEMBLY REPLACEMENT/REPAIR (CONT)

NOTE

Perform step (5) on vehicles equipped with WTEC III transmission controls.

- (5) Connect connector PX33 (9) to WTEC III TPSS (10).

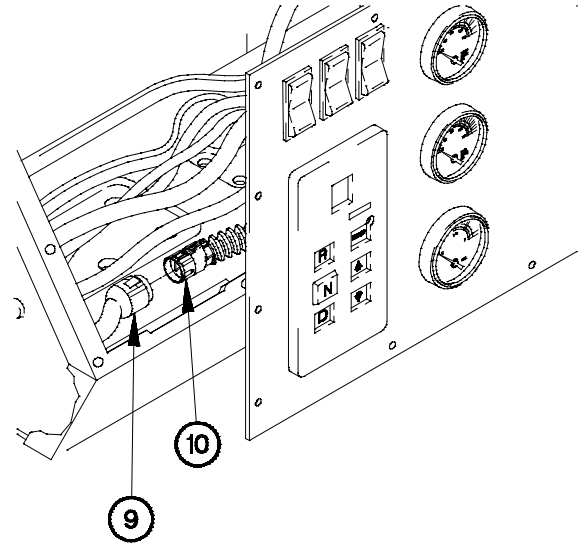

XG15D021

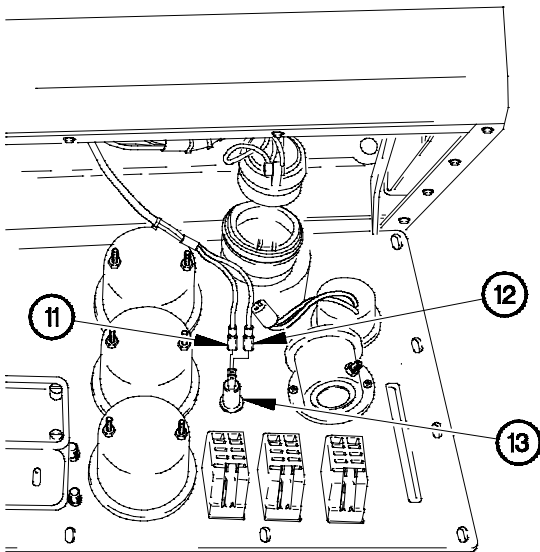

Xg15d031

- (6) Connect terminal lugs TL163 (11) and TL162 (12) to starter pushbutton switch (13).

- (7) Connect connector PX15 (14) to main light switch (15).
- (8) Connect connector PX24 (16) to dimmer switch (17).
- (9) Connect connector clamp (18) on dimmer switch (17).

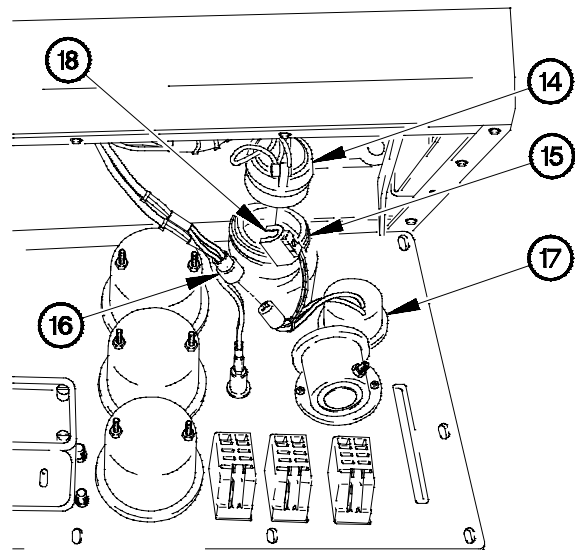

XG15D041

NOTE

Perform step (10) on M1083, M1085, M1090, M1093, and M1094.

- (10) Install terminal lugs TL160 (19), TL161 (20), and TL178 (21) on audible alarm (22) with three screws (23).

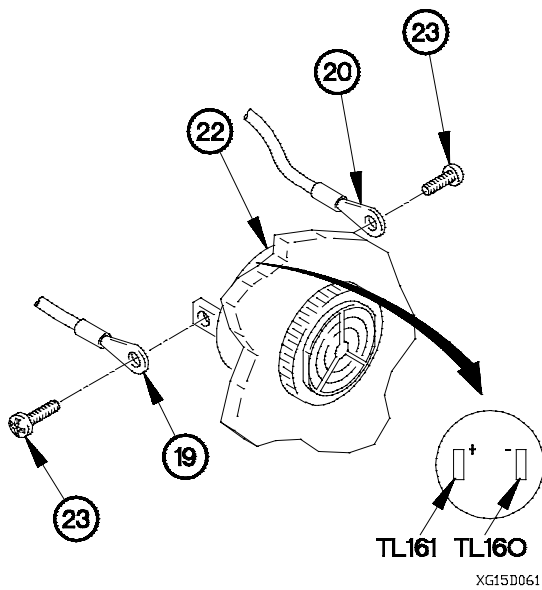
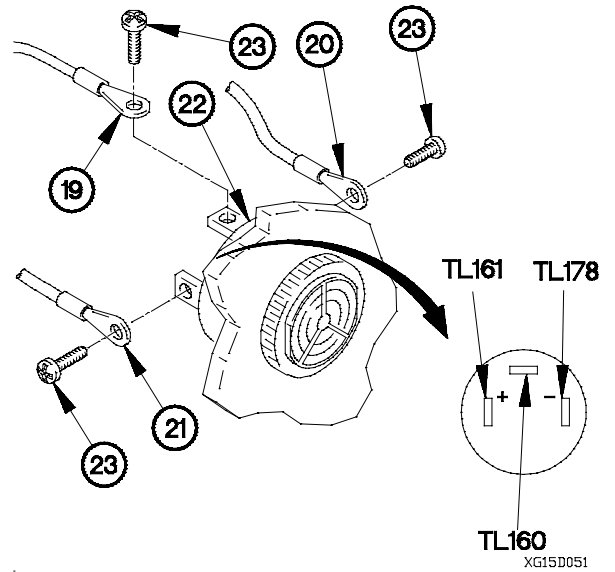

NOTE

Perform step (11) on M1084, M1086, M1088, M1089, M1092, and M1096.

- (11) Install terminal lugs TL160 (19) and TL161 (20) on audible alarm (22) with two screws (23).

7-15. INSTRUMENT PANEL ASSEMBLY REPLACEMENT/REPAIR (CONT)

(12) Connect vacuum hose (24) to AIR FILTER RESTRICTION GAUGE (25).

NOTE

- Vehicle serial numbers 0002 through 0017, 0019 through 0025, 0027 through 0031, 0033 through 0038, 0040 and 0041, 0043 through 0053, 0055 through 0089, 0091 through 0254, 0256 through 0258, 0260, 0261, 0263 through 2400, and 2402 through 3091 are not equipped with LAMP TEST switch.
- Vehicle serial numbers 0001 through 1477 were originally equipped with dashboard cable assemblies containing two unused connectors for LAMP TEST switch. Vehicle serial numbers 1478 through 3091 were originally equipped with dashboard cable assemblies without connectors for LAMP TEST switch.
- All rocker switches are connected the same way. Hazard lights switch shown. Refer to **Table 7-2. Rocker Switch Connectors** for correct combinations of rocker switches and connectors.

(13) Connect connector (26) to hazard lights switch (27).

(14) Connect connector (28) to hazard lights switch (27).

(15) Perform steps (13) and (14) on remaining rocker switches.

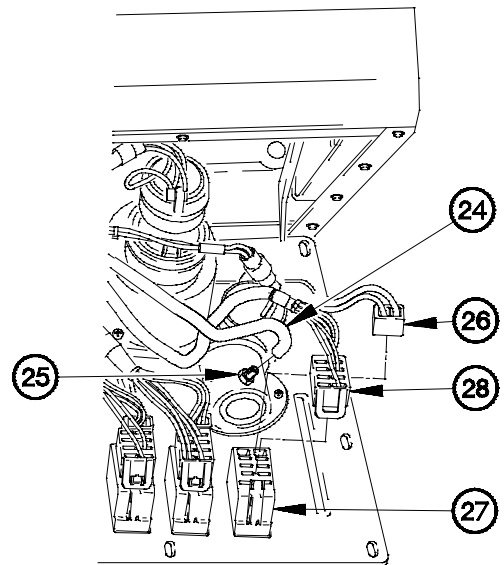

4g15d071

NOTE

All electrical gages are connected the same way. OIL PRESS gage shown. Refer to **Table 7-1.2 Electrical Gages Connectors** for correct combinations of gages and connectors.

- (16) Connect connector (29) to OIL PRESS gage connector (30).
- (17) Connect connector clamp (31) on OIL PRESS gage connector (30).
- (18) Perform steps (16) and (17) on remaining electrical gages.
- (19) Connect connector PX7 (32) to lighted indicator display (33).

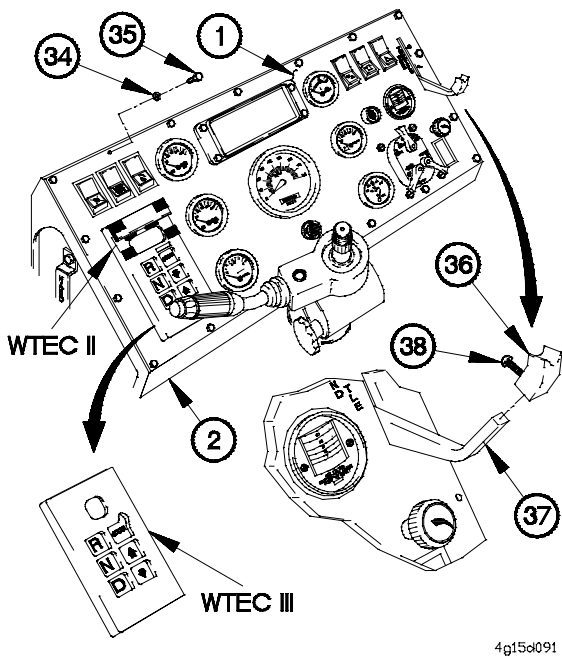
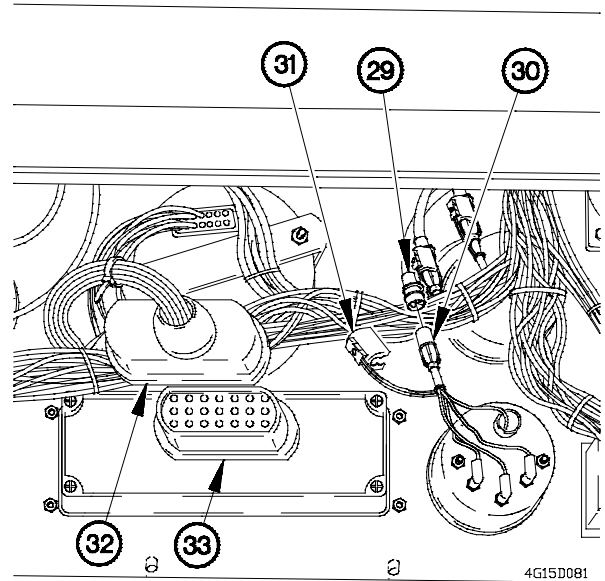

- (20) Position instrument panel assembly (1) on dashboard (2) with 16 washers (34) and screws (35).
- (21) Tighten 16 screws (35) to 24 lb-in. (3 N·m).
- (22) Install HAND THROTTLE knob (36) on HAND THROTTLE lever (37) with screw (38).

e. Follow-On Maintenance.

- (1) Install steering wheel (para 13-2).
- (2) Connect batteries (para 7-57).
- (3) Start engine (TM 9-2320-366-10-1).
- (4) Check operation of instrument panel assembly switches and gages (TM 9-2320-366-10-1).
- (5) Shut down engine (TM 9-2320-366-10-1).

End of Task.

7-16. LIGHTED INDICATOR DISPLAY REPLACEMENT/REPAIR	
This task covers:	
a. Removal	d. Installation
b. Disassembly	e. Follow-On Maintenance
c. Assembly	
INITIAL SETUP	
Equipment Conditions Batteries disconnected (para 7-57).	Materials/Parts Lamp, Incandescent (Item 65, Appendix G) Lamp, Incandescent (Item 66, Appendix G)
Tools and Special Tools Tool Kit, Genl Mech (Item 46, Appendix C) Wrench, Torque, 0-75 lb-in. (Item 90, Appendix B)	

a. Removal.

- (1) Remove four screws (1) and lighted indicator display (2) from instrument panel assembly (3).
- (2) Disconnect connector PX7 (4) from lighted indicator display (2).

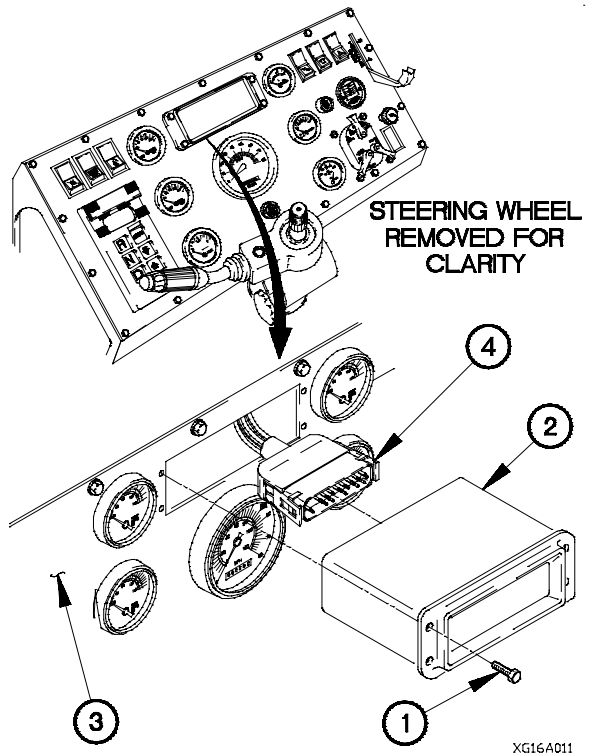

b. Disassembly.

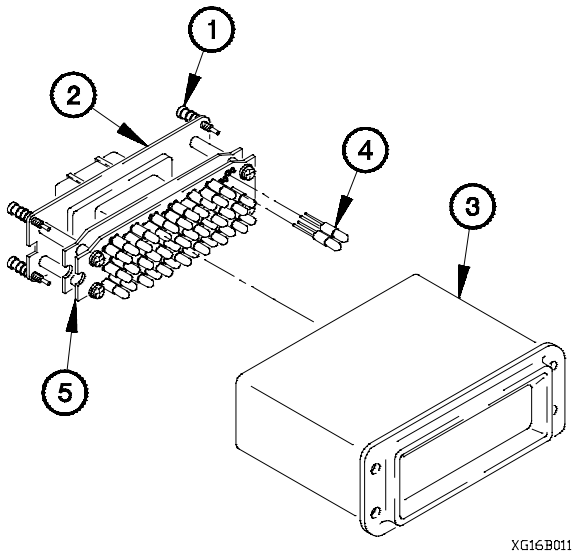

- (1) Loosen four captive screws (1) in lamp mounting panel (2).
- (2) Remove lamp mounting panel (2) from lighted indicator display housing (3).
- (3) Remove faulty lamp(s) (4) from printed circuit board (5). Discard faulty lamp(s).

c. Assembly.

NOTE

Left turn indicator, right turn indicator, and high beam indicator are 12 vdc lamps. All other lamps are 24 vdc.

- (1) Install replacement lamp(s) (1) in printed circuit board (2).
- (2) Install lamp mounting panel (3) in lighted indicator display housing (4).
- (3) Tighten four captive screws (5) in lamp mounting panel (3).

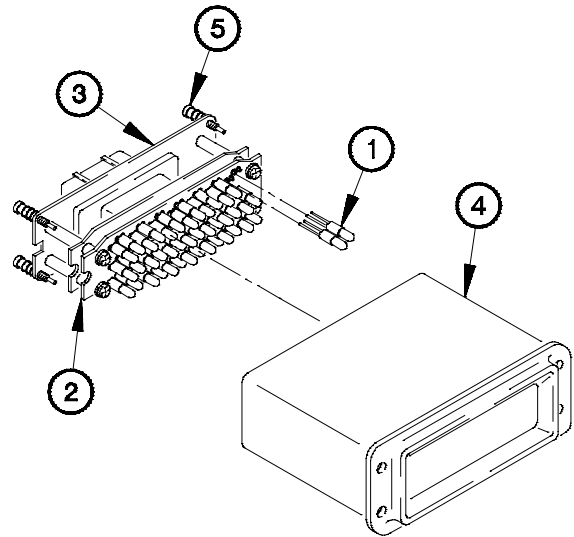

XG16C011

d. Installation.

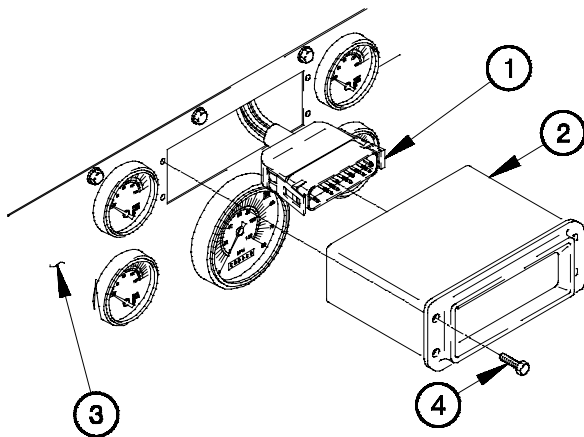

xc16D011.0twa

- (1) Connect connector PX7 (1) to lighted indicator display (2).
- (2) Position lighted indicator display (2) in instrument panel assembly (3) with four screws (4).
- (3) Tighten four screws (4) to 9 lb-in. (1 N·m).

e. Follow-On Maintenance.

- (1) Connect batteries (para 7-57).
- (2) Check operation of lighted indicator display (TM 9-2320-366-10-1).

End of Task.

7-17. MAIN LIGHT SWITCH REPLACEMENT	
This task covers:	
a. Removal b. Installation	c. Follow-On Maintenance
INITIAL SETUP	
Equipment Conditions Instrument panel assembly removed for access (para 7-15).	Materials/Parts Ties, Cable, Plastic (Item 69, Appendix D)
Tools and Special Tools Tool Kit, Genl Mech (Item 46, Appendix C) Wrench, Torque, 0-75 lb-in. (Item 90, Appendix B)	

a. Removal.

- (1) Remove three screws (1) from knobs (2).
- (2) Remove three knobs (2) and spacers (3) from main light switch (4).

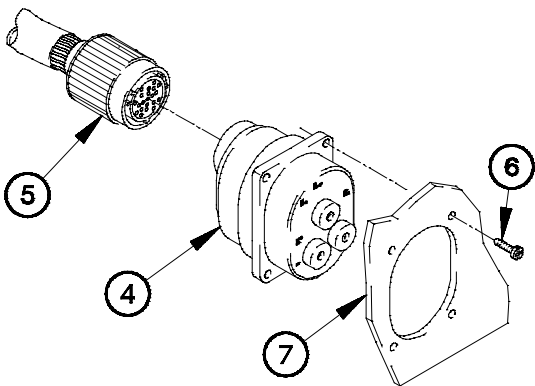
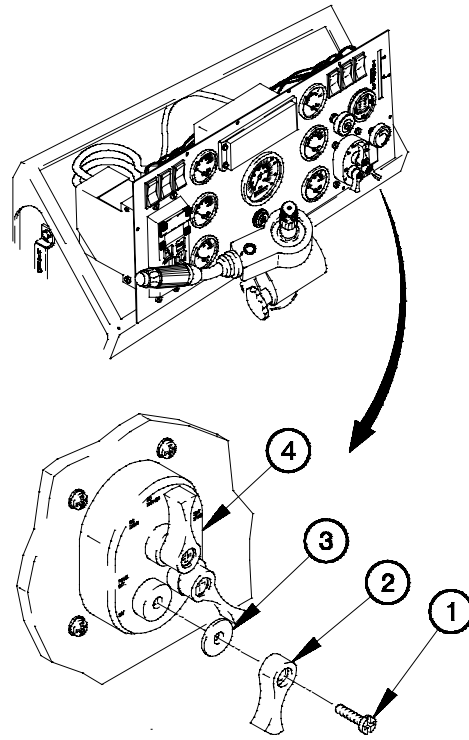

NOTE

Remove plastic cable ties as required.

- (3) Disconnect connector PX15 (5) from main light switch (4).
- (4) Remove four screws (6) and main light switch (4) from instrument panel assembly (7).

b. Installation.

(1) Position main light switch (1) in instrument panel assembly (2) with four screws (3).

(2) Tighten four screws (3) to 9 lb-in. (1 N-m).

NOTE

Install plastic cable ties as required.

(3) Connect connector PX15 (4) to main light switch (1).

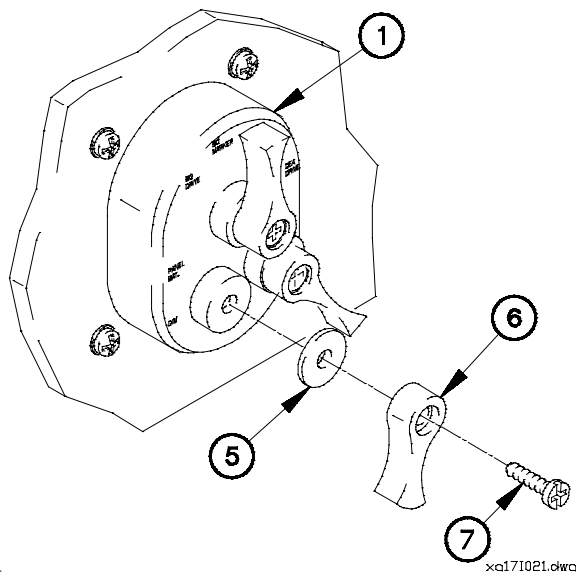
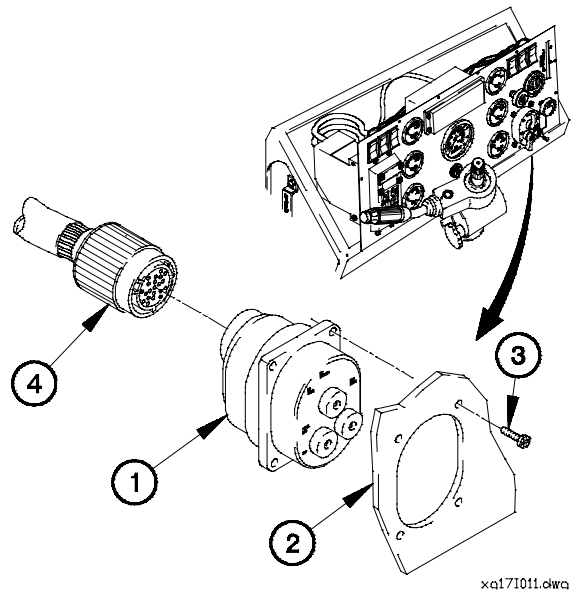

(4) Install three spacers (5) and knobs (6) on main light switch (1).

(5) Install three screws (7) in knobs (6).

c. Follow-On Maintenance.

(1) Install instrument panel assembly (para 7-15).

(2) Check lighting system operation (TM 9-2320-366-10-1).

End of Task.

7-18. ROCKER SWITCHES REPLACEMENT

This task covers:

- | | |
|---|---|
| <ul style="list-style-type: none"> a. Instrument Panel Rocker Switch Removal b. Instrument Panel Rocker Switch Installation c. Auxiliary Panel Rocker Switch Removal | <ul style="list-style-type: none"> d. Auxiliary Panel Rocker Switch Installation e. Follow-On Maintenance |
|---|---|

INITIAL SETUP

Equipment Conditions

Instrument panel assembly removed for access (for instrument panel rocker switches) (para 7-15).

Materials/Parts

Dispenser, Pressure Sensitive Adhesive Tape (Item 20, Appendix D)

Tools and Special Tools

Tool Kit, Genl Mech (Item 46, Appendix C)
Wrench, Torque, 0-75 lb-in. (Item 90, Appendix B)

a. Instrument Panel Rocker Switch Removal.

NOTE

- Vehicle serial numbers 0002 through 0017, 0019 through 0025, 0027 through 0031, 0033 through 0038, 0040, 0041, 0043 through 0053, 0055 through 0089, 0091 through 0254, 0256 through 0258, 0260, 0261, 0263 through 2400, and 2402 through 3091 are not equipped with LAMP TEST switch.
- All instrument panel rocker switches are removed the same way. Radiator fan off switch shown.
- Tag electrical connectors and connection points prior to disconnecting.

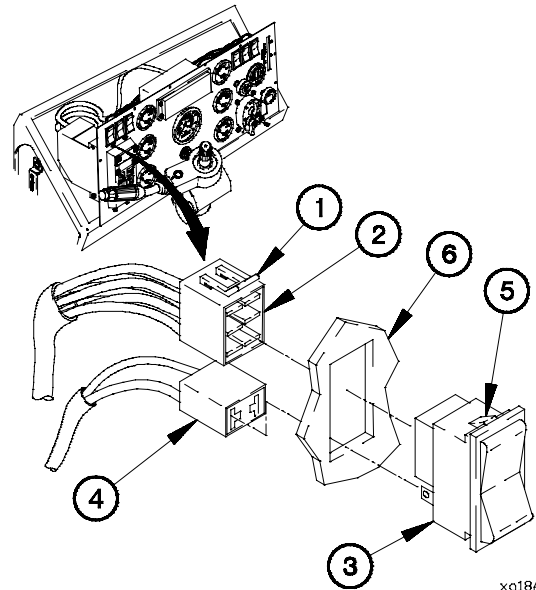

xa18A011.dwg

- (1) Lift tab (1) on connector PX1 (2).
- (2) Disconnect connector PX1 (2) from radiator fan off switch (3).
- (3) Disconnect connector PX1A (4) from radiator fan off switch (3).
- (4) Push in two tabs (5) on radiator fan off switch (3).
- (5) Remove radiator fan off switch (3) from instrument panel assembly (6).

- (6) Remove lamp base (7) from radiator fan off switch (3).
- (7) Remove lamp (8) from lamp base (7).

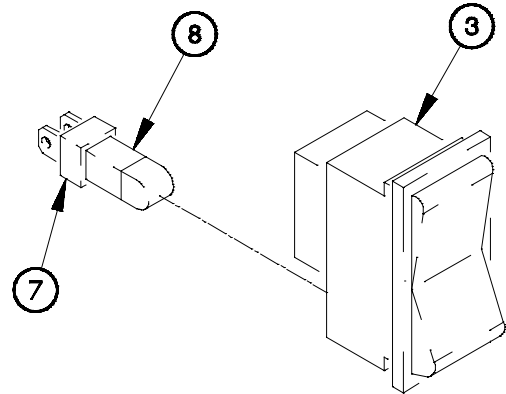

b. Instrument Panel Rocker Switch Installation.

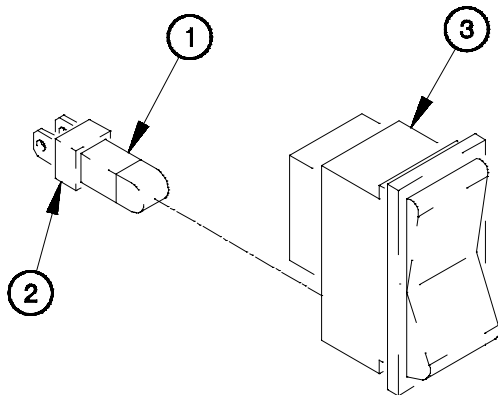

×a184021.dwg

NOTE

All instrument panel rocker switches are installed the same way. Radiator fan off switch shown.

- (1) Install lamp (1) in lamp base (2).
- (2) Install lamp base (2) in radiator fan off switch (3).

×a18B011.dwg

- (3) Install radiator fan off switch (3) in instrument panel assembly (4).
- (4) Connect connector PX1A (5) to radiator fan off switch (3).
- (5) Connect connector PX1 (6) to radiator fan off switch (3).

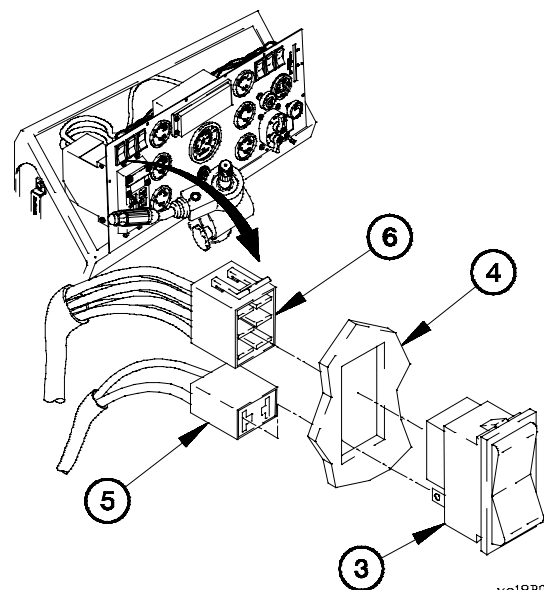

×a18B021.dwg

7-18. ROCKER SWITCHES REPLACEMENT (CONT)

c. Auxiliary Panel Rocker Switch Removal.

- (1) Remove six screws (1) from auxiliary panel (2).
- (2) Lift auxiliary panel (2) outward to gain access.

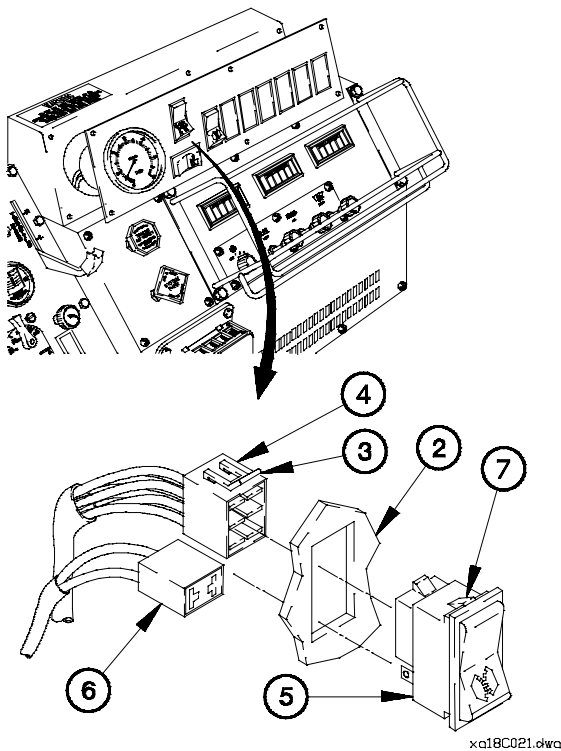
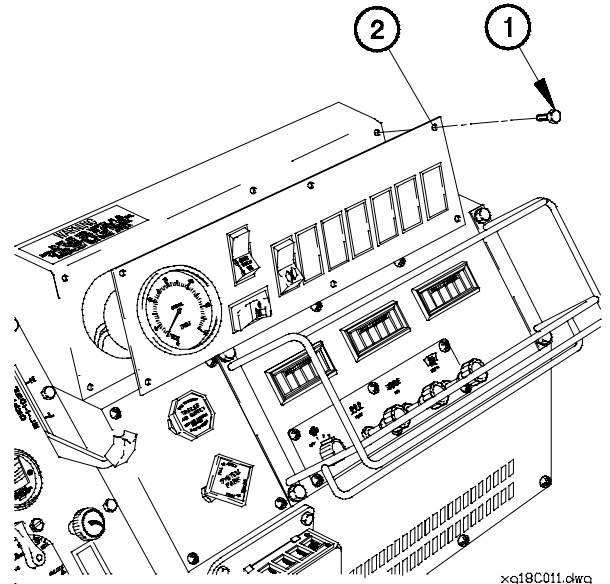

NOTE

- All auxiliary panel rocker switches are removed the same way. PTO switch shown.
 - Tag electrical connectors and connection points prior to disconnecting.
- (3) Lift tab (3) on connector P903 (4).
 - (4) Disconnect connector P903 (4) from PTO switch (5).
 - (5) Disconnect connector P903A (6) from PTO switch (5).
 - (6) Push in two tabs (7) on PTO switch (5).
 - (7) Remove PTO switch (5) from auxiliary panel (2).

- (8) Remove lamp base (8) from PTO switch (5).
- (9) Remove lamp (9) from lamp base (8).

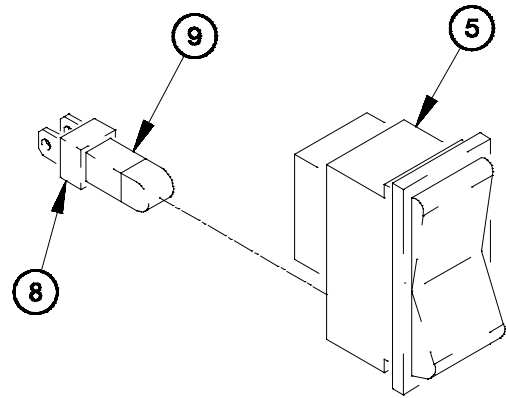

d. Auxiliary Panel Rocker Switch Installation.

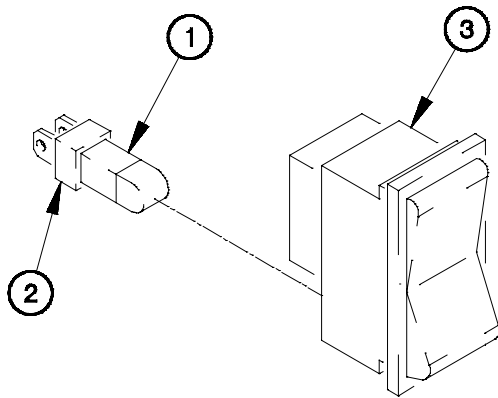

xa18C031.dwg

NOTE

All auxiliary panel rocker switches are installed the same way. PTO switch shown.

- (1) Install lamp (1) in lamp base (2).
- (2) Install lamp base (2) in PTO switch (3).

xa18D011.dwg

- (3) Install PTO switch (3) in auxiliary panel (4).
- (4) Connect connector P903A (5) to PTO switch (3).
- (5) Connect connector P903 (6) to PTO switch (3).

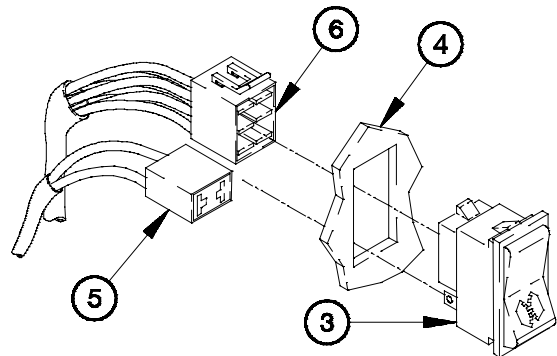

xa18D021.dwg

7-18. ROCKER SWITCHES REPLACEMENT (CONT)

(6) Position auxiliary panel (4) on auxiliary panel housing (7) with six screws (8).

(7) Tighten six screws (8) to 18 lb-in. (2 N·m).

e. Follow-On Maintenance.

(1) Install instrument panel assembly (for instrument panel rocker switches) (para 7-15).

(2) Check rocker switch operation (TM 9-2320-366-10-1).

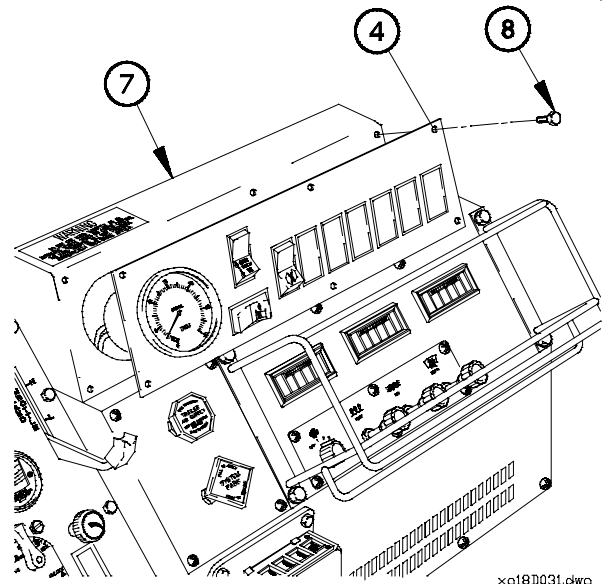

xca18D031.dwg

End of Task.

7-19. START INHIBIT PUSHBUTTON SWITCH REPLACEMENT

This task covers:

- a. Removal
- b. Installation
- c. Follow-On Maintenance

INITIAL SETUP

Equipment Conditions

- Batteries disconnected (para 7-57).
- PDP cover removed (para 16-2).

Materials/Parts

- Dispenser, Pressure Sensitive Adhesive Tape (Item 20, Appendix D)

Tools and Special Tools

- Tool Kit, Genl Mech (Item 46, Appendix C)

a. Removal.

- (1) Remove three screws (1) and washers (2) from PDP (3).
- (2) Remove three screws (4) from PDP (3).
- (3) Lift PDP (3) outward to gain access.

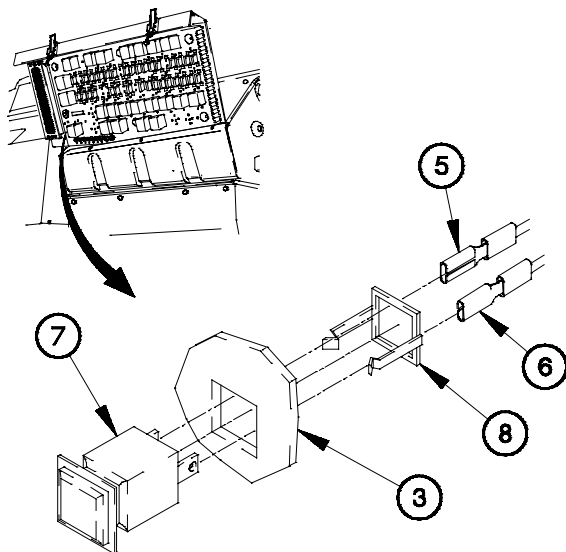

×a19R021.dwg

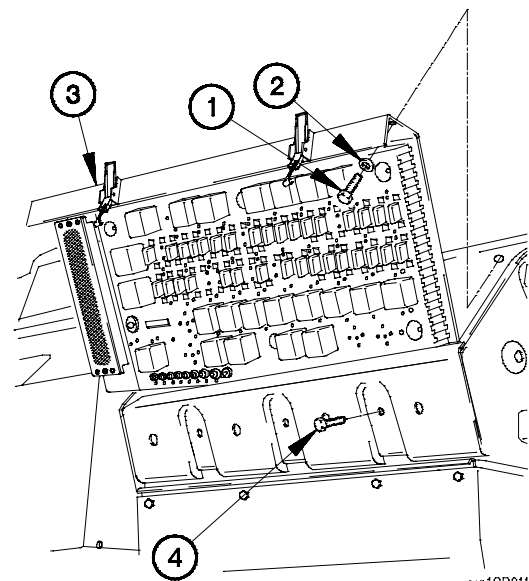

×a19R011.dwg

NOTE

Tag electrical connectors and connection points prior to disconnecting.

- (4) Disconnect terminal lugs TL158 (5) and TL159 (6) from start inhibit pushbutton switch (7).
- (5) Remove spring clip (8) and start inhibit pushbutton switch (7) from PDP (3).

7-19. START INHIBIT PUSHBUTTON SWITCH REPLACEMENT (CONT)

b. Installation.

- (1) Install start inhibit pushbutton switch (1) in PDP (2) with spring clip (3).
- (2) Connect terminal lugs TL159 (4) and TL158 (5) to start inhibit pushbutton switch (1).

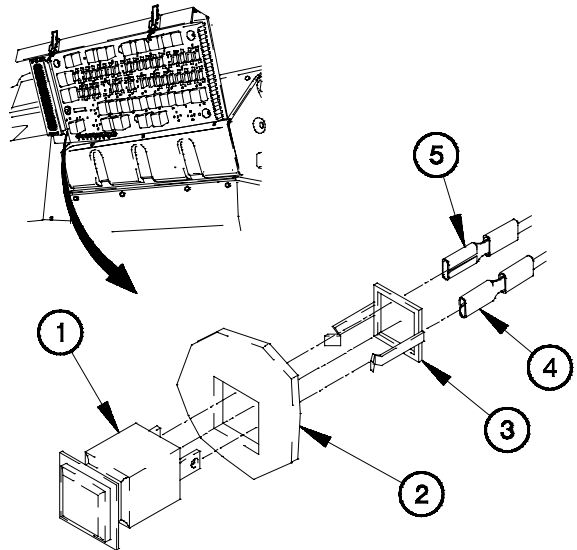

xa191011.dwa

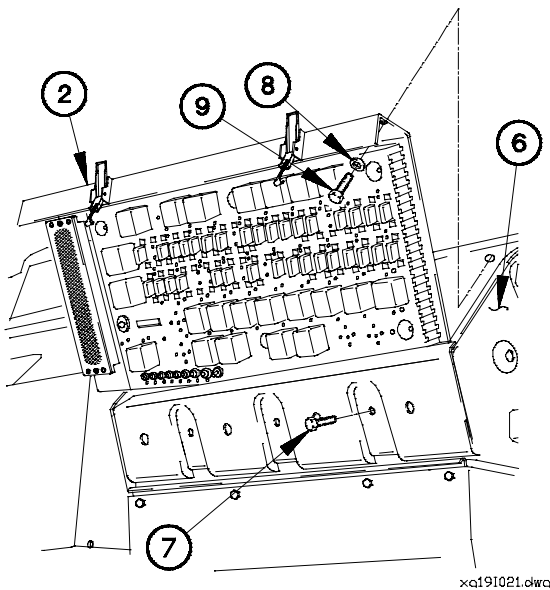

xa191021.dwa

- (3) Position PDP (2) on dashboard (6).
- (4) Install three screws (7) in PDP (2).
- (5) Install three washers (8) and screws (9) in PDP (2).

c. Follow-On Maintenance.

- (1) Install PDP cover (para 16-2).
- (2) Connect batteries (para 7-57).

End of Task.

7-20. STARTER PUSHBUTTON SWITCH REPLACEMENT

This task covers:

- a. Removal
- b. Installation
- c. Follow-On Maintenance

INITIAL SETUP

Equipment Conditions

Instrument panel assembly removed for access (para 7-15).

Tools and Special Tools

Tool Kit, Genl Mech (Item 46, Appendix C)
Wrench, Torque, 0-200 lb-in. (Item 59, Appendix C)
Socket Set, Socket Wrench (Item 34, Appendix C)

Materials/Parts

Dispenser, Pressure Sensitive Adhesive Tape (Item 20, Appendix D)

a. Removal.

NOTE

Tag wires and connection points prior to disconnecting.

- (1) Disconnect terminal lugs TL162 (1) and TL163 (2) from starter pushbutton switch (3).
- (2) Remove nut (4), washer (5), and starter pushbutton switch (3) from instrument panel assembly (6).

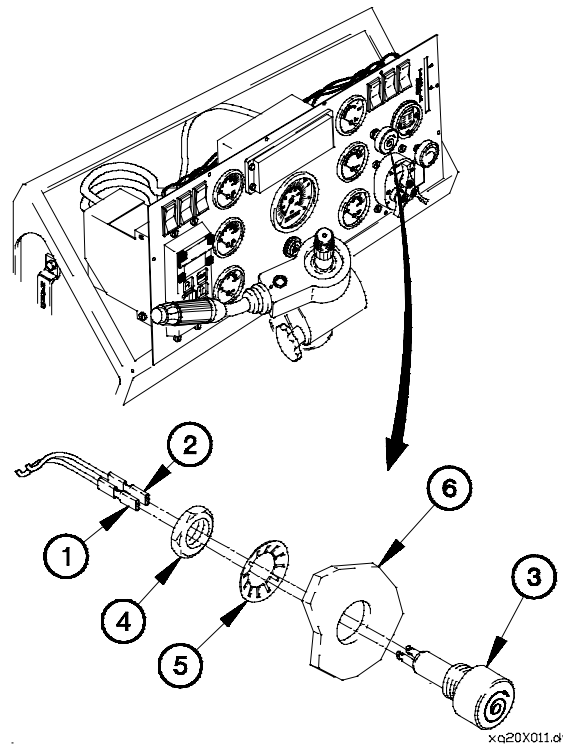

b. Installation.

- (1) Position starter pushbutton switch (3) in instrument panel assembly (6) with washer (5) and nut (4).
- (2) Tighten nut (4) to 57-70 lb-in. (6-8 N-m).
- (3) Connect terminal lugs TL163 (2) and TL162 (1) to starter pushbutton switch (3).

c. Follow-On Maintenance.

- (1) Install instrument panel assembly (para 7-15).
- (2) Start engine (TM 9-2320-366-10-1).
- (3) Shut down engine (TM 9-2320-366-10-1).

End of Task.

7-21. TACHOMETER REPLACEMENT

This task covers:

- a. Removal
- b. Installation
- c. Follow-On Maintenance

INITIAL SETUP

Equipment Conditions

Batteries disconnected (para 7-57).

Materials/Parts

Nut, Self-Locking (2) (Item 133, Appendix G)

Tools and Special Tools

Tool Kit, Genl Mech (Item 46, Appendix C)
 Wrench, Torque, 0-75 lb-in. (Item 90, Appendix B)

a. Removal.

- (1) Remove six screws (1) and auxiliary panel (2) from auxiliary panel housing (3).
- (2) Lift auxiliary panel (2) outward to gain access.

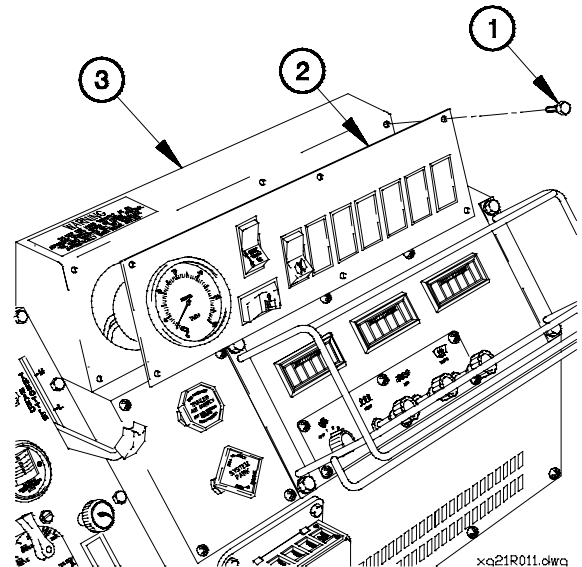

xa21R011.dwg

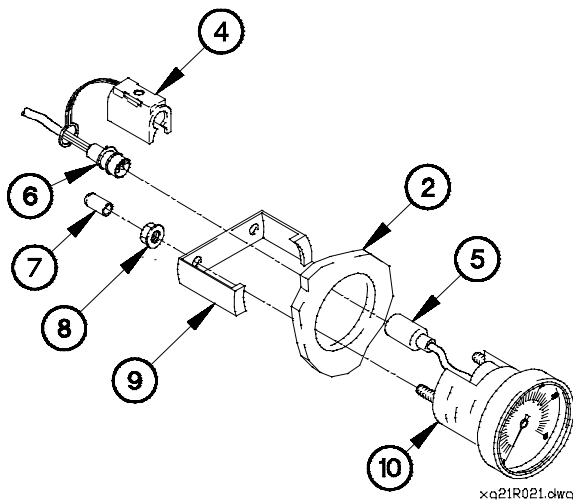

xa21R021.dwg

- (3) Disconnect connector clamp (4) from tachometer connector (5).
- (4) Disconnect connector P901 (6) from tachometer connector (5).
- (5) Remove two protective caps (7), self-locking nuts (8), and retaining ring (9) from tachometer (10). Discard self-locking nuts.
- (6) Remove tachometer (10) from auxiliary panel (2).

b. Installation.

- (1) Position tachometer (1) in auxiliary panel (2) with retaining ring (3) and two self-locking nuts (4).
- (2) Tighten two self-locking nuts (4) to 9 lb-in. (1 N-m).
- (3) Install two protective caps (5) on tachometer (1).
- (4) Connect connector P901 (6) to tachometer connector (7).
- (5) Connect connector clamp (8) on tachometer connector (7).

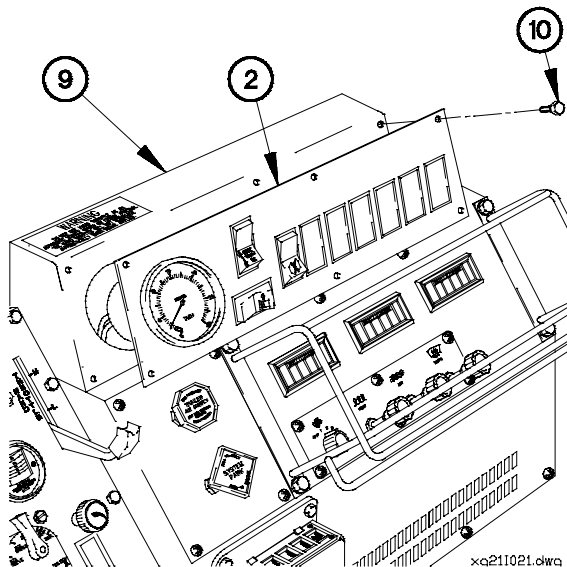
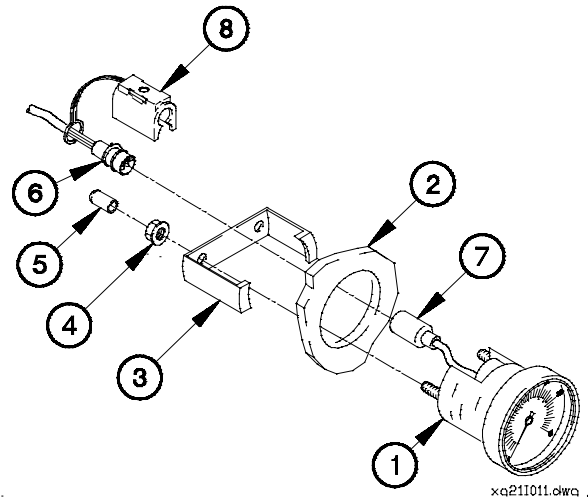

- (6) Position auxiliary panel (2) on auxiliary panel housing (9) with six screws (10).
- (7) Tighten six screws (10) to 18 lb-in. (2 N-m).

c. Follow-On Maintenance.

- (1) Connect batteries (para 7-57).
- (2) Start engine (TM 9-2320-366-10-1).
- (3) Check tachometer operation (TM 9-2320-366-10-1).
- (4) Shut down engine (TM 9-2320-366-10-1).

End of Task.

7-22. COOLANT TEMPERATURE LIGHT SWITCH REPLACEMENT

This task covers:

- a. Removal
- b. Installation
- c. Follow-On Maintenance

INITIAL SETUP

Equipment Conditions

- Cab raised (TM 9-2320-366-10-1).
- Batteries disconnected (para 7-57).

Tools and Special Tools

- Tool Kit, Genl Mech (Item 46, Appendix C)
- Pan, Drain (Item 24, Appendix C)
- Goggles, Industrial (Item 15, Appendix C)
- Wrench, Torque, 0-175 lb-ft (Item 58, Appendix C)
- Crowfoot Attachment, Socket Wrench (Item 6, Appendix B)

Materials/Parts

- Antiseize Compound (Item 58, Appendix D)
- Ties, Cable, Plastic (Item 69, Appendix D)
- Antifreeze, Ethylene Glycol, Permanent (Item 12, Appendix D)

WARNING

- Coolant may be very hot and under pressure from engine operation. Ensure engine is cool before performing maintenance. Failure to comply may result in injury to personnel.
- Wear appropriate eye protection when working under vehicle due to the possibility of falling debris. Failure to comply may result in injury to personnel.

a. Removal.

- (1) Remove radiator cap (1) from radiator overflow tank (2).
- (2) Position container under radiator draincock (3).
- (3) Open radiator draincock (3) and drain approximately one gal (one L) of coolant.
- (4) Close radiator draincock (3).

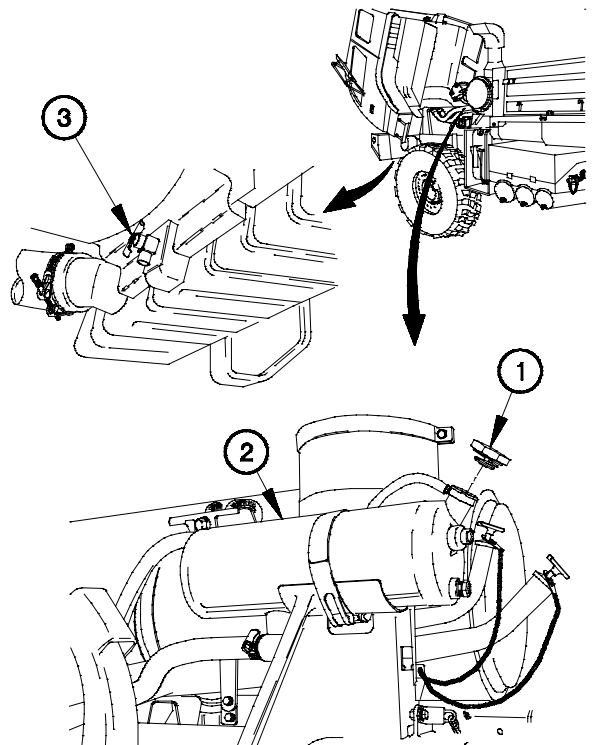

xa22R011.dwa

NOTE

Remove plastic cable ties as required.

- (5) Disconnect connector clamp (4) from coolant temperature light switch (5).
- (6) Disconnect connector P37 (6) from coolant temperature light switch (5).
- (7) Remove coolant temperature light switch (5) from thermostat housing (7).

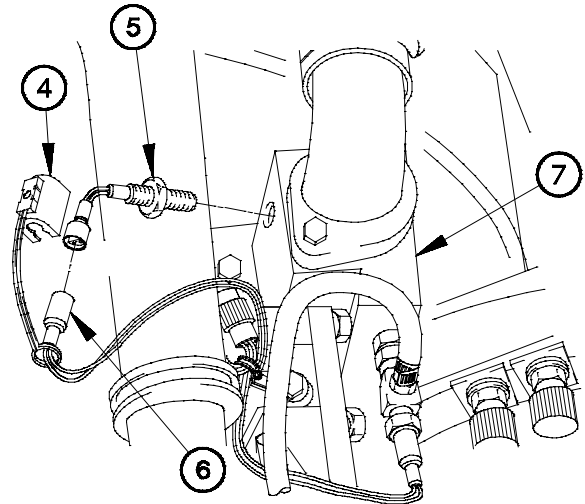

xq22R021.dwg

b. Installation.

WARNING

Adhesives, solvents, and sealing compounds can burn easily, can give off harmful vapors, and are harmful to skin and clothing. Keep away from open fire and use in a well-ventilated area. If adhesive, solvent, or sealing compound gets on skin or clothing, wash immediately with soap and water. Failure to comply may result in injury to personnel.

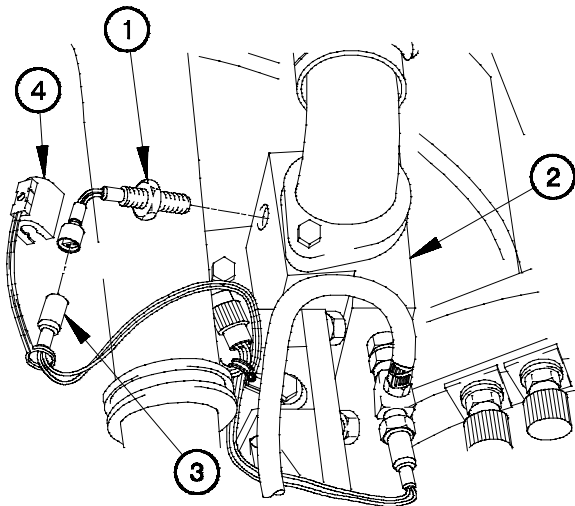

xq22I011.dwg

- (1) Apply antiseize compound to threads of coolant temperature light switch (1).
- (2) Position coolant temperature light switch (1) in thermostat housing (2).
- (3) Tighten coolant temperature light switch (1) to 20-23 lb-ft (27-31 N·m).
- (4) Connect connector P37 (3) to coolant temperature light switch (1).

NOTE

Install plastic cable ties as required.

- (5) Connect connector clamp (4) on coolant temperature light switch (1).

7-22. COOLANT TEMPERATURE LIGHT SWITCH REPLACEMENT (CONT)
--

c. Follow-On Maintenance.

- (1) Add coolant to radiator overflow tank (TM 9-2320-366-10-2).
- (2) Connect batteries (para 7-57).
- (3) Lower cab (TM 9-2320-366-10-1).
- (4) Start engine (TM 9-2320-366-10-1).
- (5) Check for coolant leaks under vehicle.
- (6) Check coolant level after normal temperature is reached. Add coolant as required (TM 9-2320-366-10-2).
- (7) Raise cab (TM 9-2320-366-10-1).
- (8) Check for leaks around coolant temperature light switch.
- (9) Lower cab (TM 9-2320-366-10-1).
- (10) Shut down engine (TM 9-2320-366-10-1).

End of Task.

7-23. M1090/M1094 DUMP BODY SWITCH REPLACEMENT/ADJUSTMENT

This task covers:

- a. Removal
- b. Installation
- c. Adjustment
- d. Follow-On Maintenance

INITIAL SETUP

Equipment Conditions

Dump body raised to maintenance position (TM 9-2320-366-10-1).
 Engine shut down (TM 9-2320-366-10-1).

Tools and Special Tools

Tool Kit, Genl Mech (Item 46, Appendix C)
 Goggles, Industrial (Item 15, Appendix C)

Materials/Parts

Lockwasher (Item 80, Appendix G)

Personnel Required

(2)

a. Removal.

- (1) Disconnect connector P25 (1) from dump body switch connector (2).

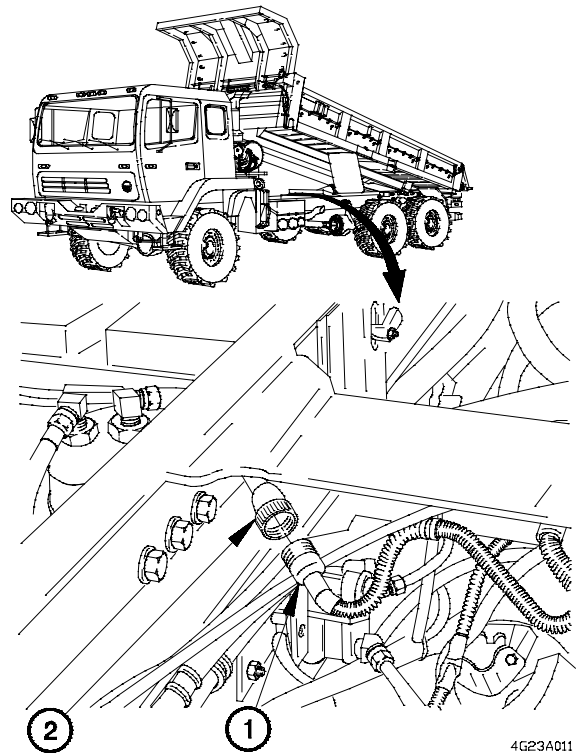

4G23A011

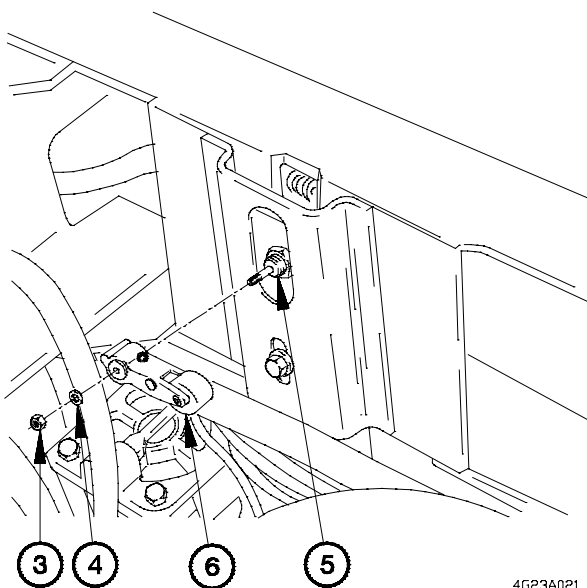

4G23A021

- (2) Remove nut (3) and washer (4) from dump body switch (5).
- (3) Remove lever (6) from dump body switch (5).

7-23. M1090/M1094 DUMP BODY SWITCH REPLACEMENT/ADJUSTMENT (CONT)

- (4) Remove nut (7), lockwasher (8), and dump body switch (5) from mounting plate (9). Discard lockwasher.

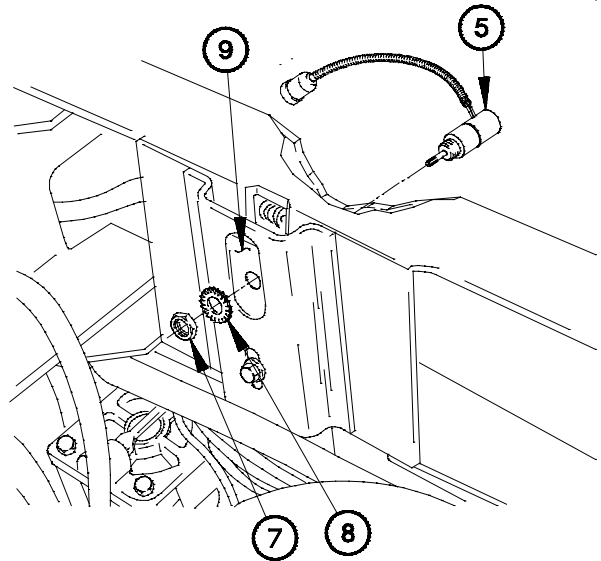

4G23A031

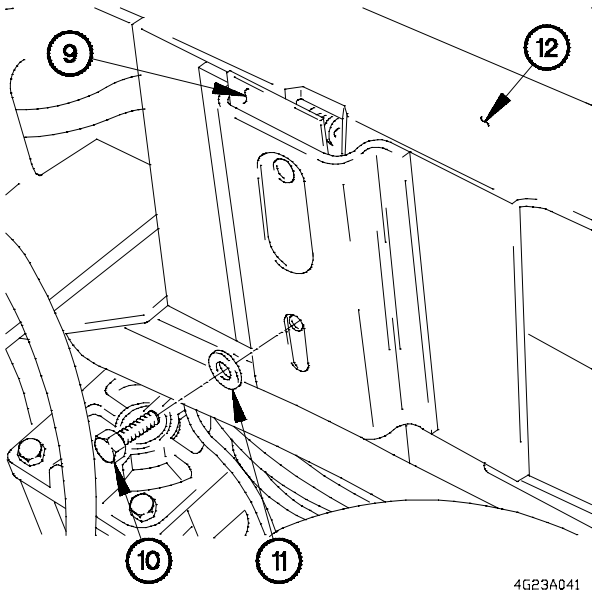

4G23A041

- (5) Remove screw (10), washer (11), and mounting plate (9) from frame (12).

b. Installation.

- (1) Position mounting plate (1) on frame (2) with washer (3) and screw (4).

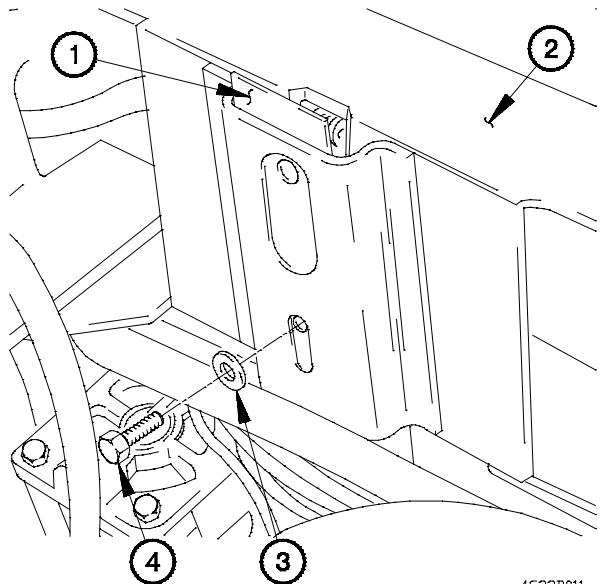

4G23B011

- (2) Install dump body switch (5) in mounting plate (1) with lockwasher (6) and nut (7).

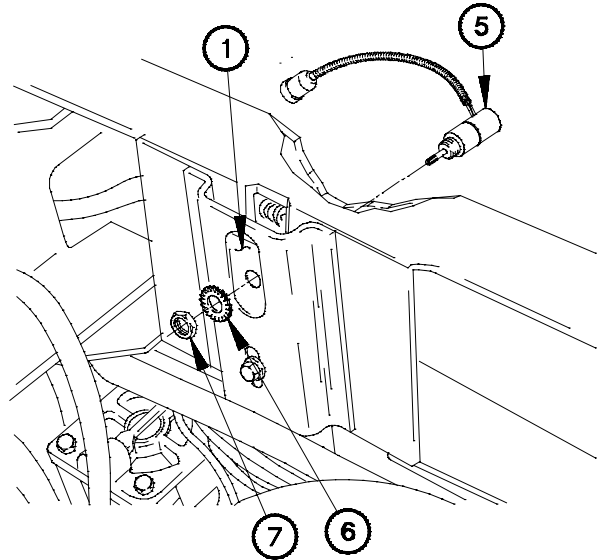

4G23B021

CAUTION

Lever must be installed so that it is approximately level before adjustment. Failure to comply may result in damage to equipment.

- (3) Install lever (8) on dump body switch (5) with washer (9) and nut (10).

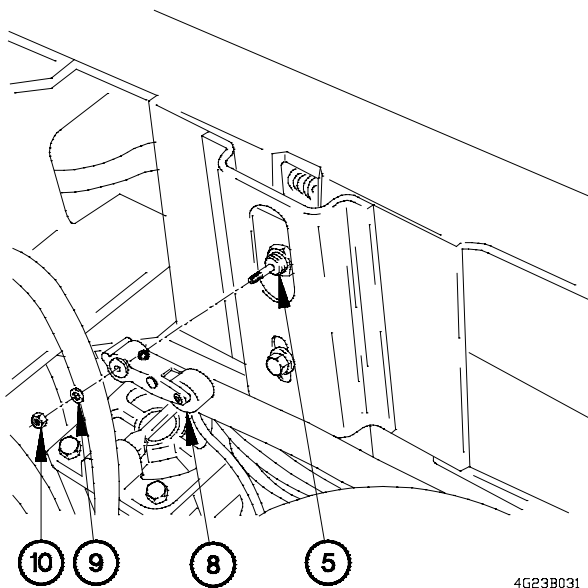

4G23B031

- (4) Connect dump body switch connector (11) to connector P25 (12).

- (5) Lower dump body (TM 9-2320-366-10-1).

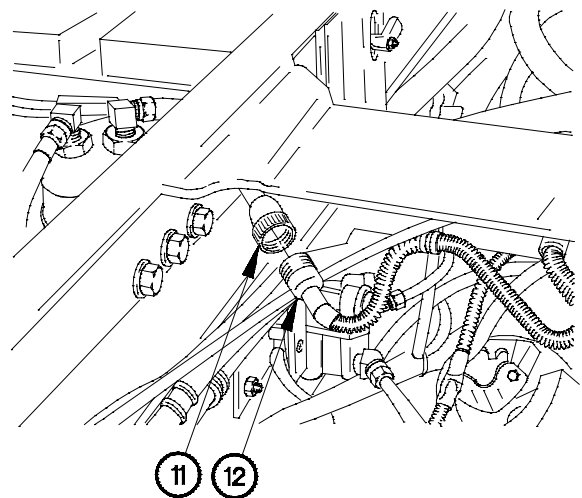

4G23B041

7-23. M1090/M1094 DUMP BODY SWITCH REPLACEMENT/ADJUSTMENT (CONT)

c. Adjustment.

WARNING

- Wear appropriate eye protection when working under vehicle due to the possibility of falling debris. Failure to comply may result in injury to personnel.
- Ensure exhaust system is cool before performing maintenance. Failure to comply may result in injury to personnel.

- (1) Loosen screw (1) in mounting plate (2).
- (2) Position master power switch to on (TM 9-2320-366-10-1).

NOTE

Step (3) requires the aid of an assistant.

- (3) Push up on lever (3) until DUMP BODY UP indicator (4) goes out.
- (4) Tighten screw (1).
- (5) Position master power switch to off (TM 9-2320-366-10-1).

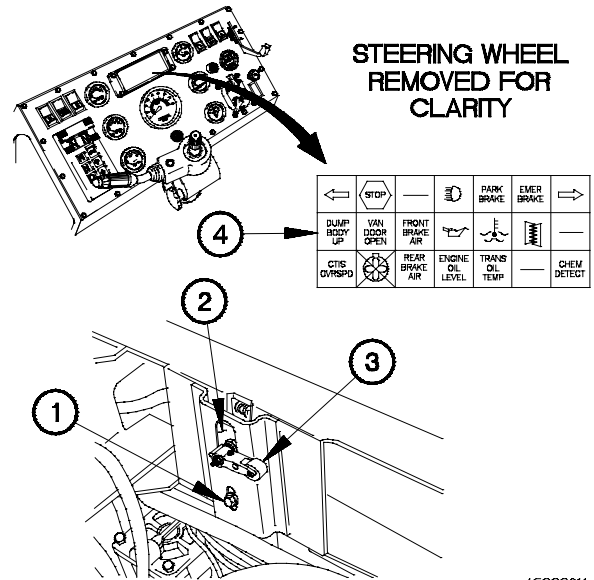

d. Follow-On Maintenance.

- (1) Raise dump body and check that DUMP BODY UP indicator is lit (TM 9-2320-366-10-1).
- (2) Lower dump body and check that DUMP BODY UP indicator goes out (TM 9-2320-366-10-1).
- (3) Shut down engine (TM 9-2320-366-10-1).

End of Task.

7-24. FAN AND DIFFERENTIAL LOCK SOLENOIDS REPLACEMENT

This task covers:

- a. Removal
- b. Installation
- c. Follow-On Maintenance

INITIAL SETUP

Equipment Conditions

- Air tanks drained (TM 9-2320-366-10-1).
- Batteries disconnected (para 7-57).
- Kick panel removed (para 16-3).

Tools and Special Tools

- Tool Kit, Genl Mech (Item 46, Appendix C)

Materials/Parts

- Dispenser, Pressure Sensitive Adhesive Tape (Item 20, Appendix D)

a. Removal.

- (1) Disconnect fan solenoid connector (1) from connector PX34 (2).
- (2) Disconnect differential lock solenoid connector (3) from connector PX50 (4).

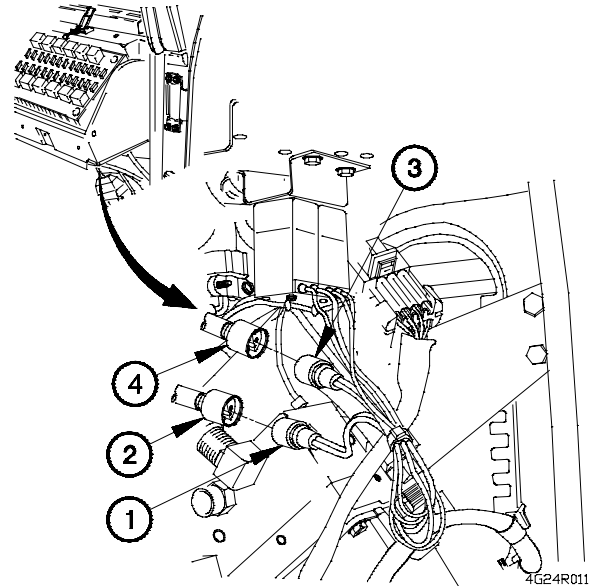

4G24R011

NOTE

Tag air hoses and connection points prior to disconnecting.

- (3) Disconnect air hose (5) from 90-degree fitting (6).
- (4) Disconnect two air hoses (7) from fittings (8).
- (5) Remove four screws (9) and bracket (10) from dashboard (11).

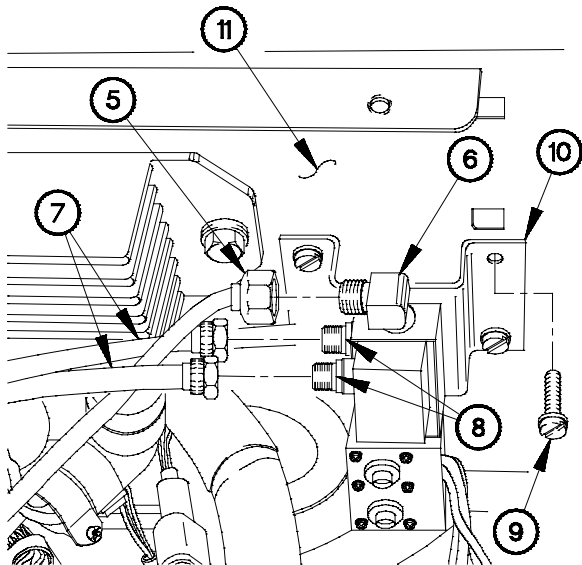

4G24R021

7-24. FAN AND DIFFERENTIAL LOCK SOLENOIDS REPLACEMENT (CONT)

- (6) Remove two screws (12) and bracket (10) from solenoids (13).
- (7) Remove 90-degree fitting (6) from solenoids (13).
- (8) Remove two fittings (8) from solenoids (13).
- (9) Remove plug (14) from solenoids (13).

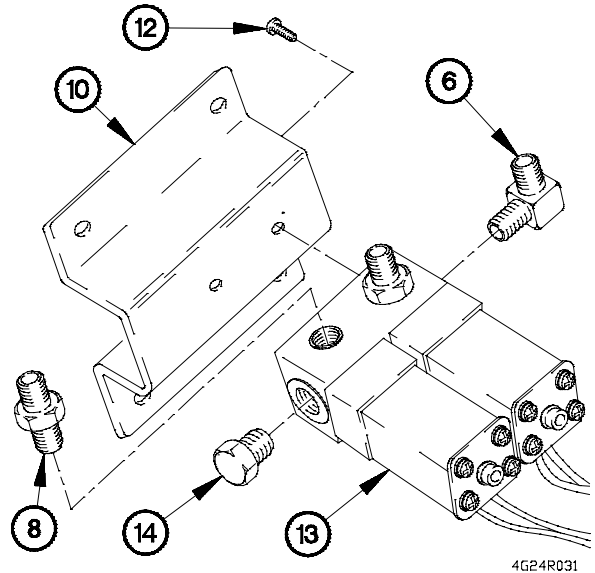

4G24R031

b. Installation.

WARNING

Adhesives, solvents, and sealing compounds can burn easily, can give off harmful vapors, and are harmful to skin and clothing. Keep away from open fire and use in a well-ventilated area. If adhesive, solvent, or sealing compound gets on skin or clothing, wash immediately with soap and water. Failure to comply may result in injury to personnel.

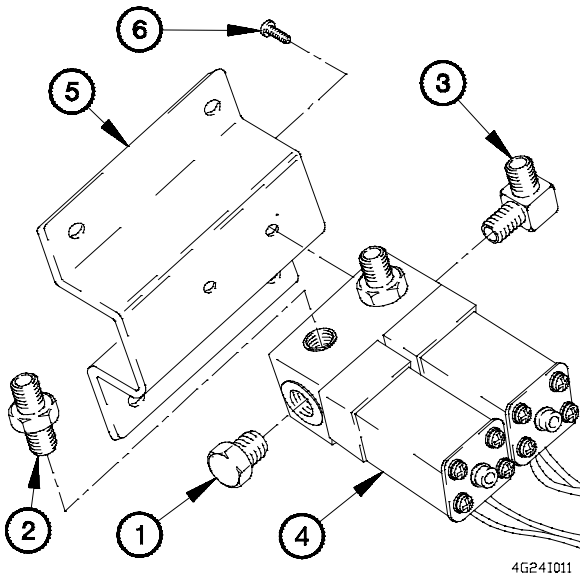

4G24I011

- (1) Apply antiseize compound to threads of plug (1), two fittings (2), and 90-degree fitting (3).
- (2) Install plug (1) in solenoids (4).
- (3) Install two fittings (2) in solenoids (4).
- (4) Install 90-degree fitting (3) in solenoids (4).
- (5) Install bracket (5) on solenoids (4) with two screws (6).

- (6) Install bracket (5) on dashboard (7) with four screws (8).
- (7) Connect two air hoses (9) to fittings (2).
- (8) Connect air hose (10) to 90-degree fitting (3).

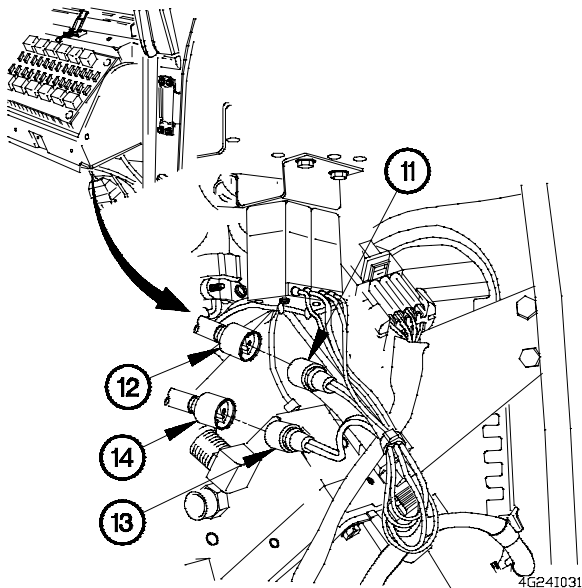
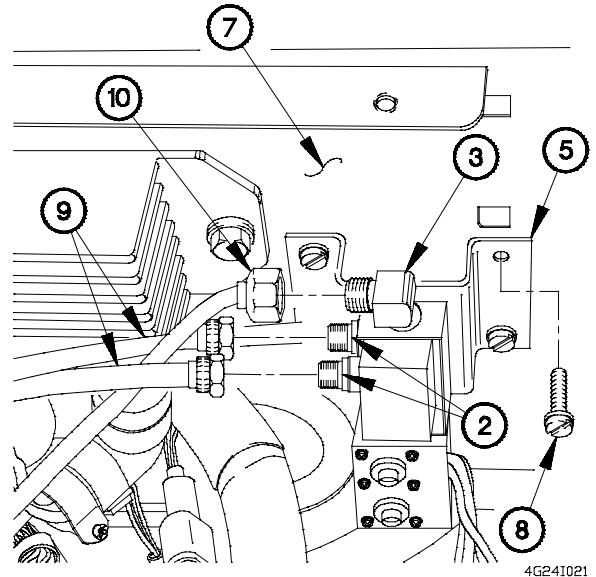

- (9) Connect differential lock solenoid connector (11) to connector PX50 (12).
- (10) Connect fan solenoid connector (13) to connector PX34 (14).

c. Follow-On Maintenance.

- (1) Install kick panel (para 16-3).
- (2) Connect batteries (para 7-57).
- (3) Start engine and allow engine temperature to rise to normal operating levels (TM 9-2320-366-10-1).
- (4) Check operation of fan and differential locks (TM 9-2320-366-10-1).
- (5) Shut down engine (TM 9-2320-366-10-1).

End of Task.

7-25. FLASHER UNIT REPLACEMENT

This task covers:

- a. Removal
- b. Installation
- c. Follow-On Maintenance

INITIAL SETUP

Equipment Conditions

- Batteries disconnected (para 7-57).
- Kick panel removed (para 16-3).

Tools and Special Tools

- Tool Kit, Genl Mech (Item 46, Appendix C)

a. Removal.

- (1) Remove two screws (1), washers (2), and flasher unit (3) from dashboard (4).
- (2) Disconnect connector PX20 (5) from flasher unit (3).

b. Installation.

- (1) Connect connector PX20 (5) to flasher unit (3).
- (2) Install flasher unit (3) on dashboard (4) with two washers (2) and screws (1).

c. Follow-On Maintenance.

- (1) Install kick panel (para 16-3).
- (2) Connect batteries (para 7-57).
- (3) Check turn signal and hazard lights operation (TM 9-2320-366-10-1).

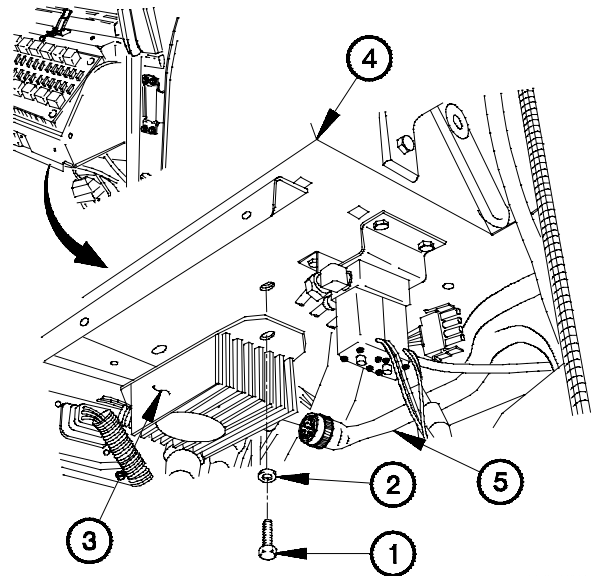

4G25X011

End of Task.

7-26. TURN SIGNAL SWITCH REPLACEMENT

This task covers:

- a. Removal
- b. Installation
- c. Follow-On Maintenance

INITIAL SETUP

Equipment Conditions

Instrument panel assembly removed for access (para 7-15).

Materials/Parts

Dispenser, Pressure Sensitive Adhesive Tape (Item 20, Appendix D)

Tools and Special Tools

Tool Kit, Genl Mech (Item 46, Appendix C)

a. Removal.

NOTE

Tag connectors and connection points prior to disconnecting.

- (1) Disconnect turn signal switch connectors (1 and 2) from connectors P18 and J19 (3 and 4).
- (2) Remove turn signal switch connectors (1 and 2) through opening (5) in dashboard (6).

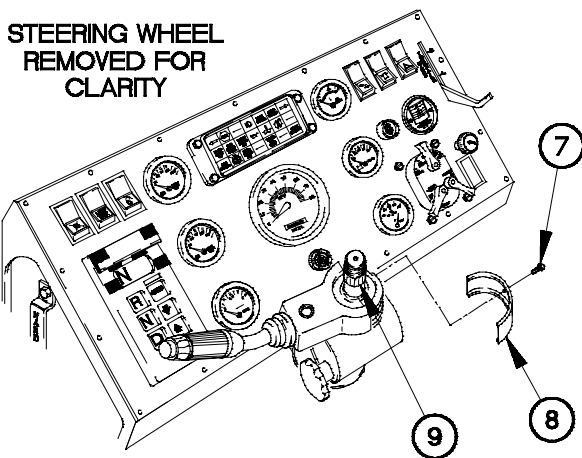
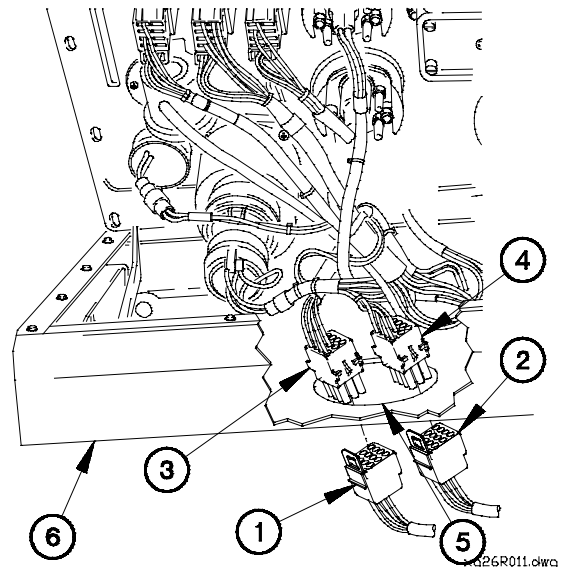

- (3) Remove screw (7) and sleeve (8) from steering column (9).

xa26R021.dwg

7-26. TURN SIGNAL SWITCH REPLACEMENT (CONT)

- (4) Remove two screws (10), collar half (11), and turn signal switch (12) from steering column (9).

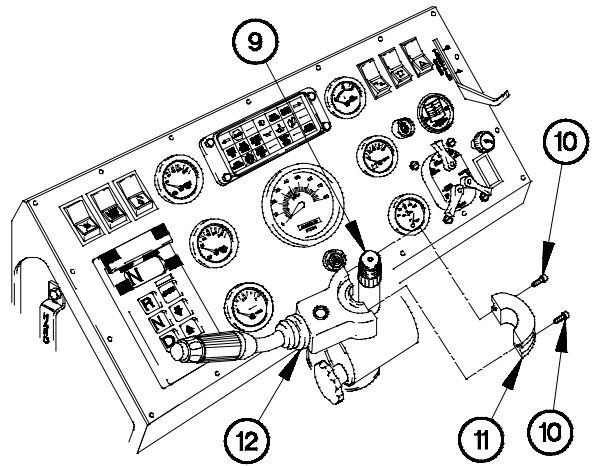

xa26R031.dwg

b. Installation.

STEERING WHEEL
REMOVED FOR
CLARITY

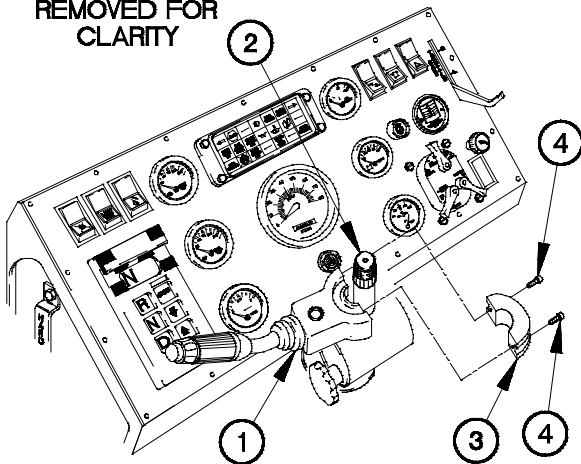

xa26I011.dwg

- (1) Install turn signal switch (1) on steering column (2) with collar half (3) and two screws (4).

- (2) Install sleeve (5) on steering column (2) with screw (6).

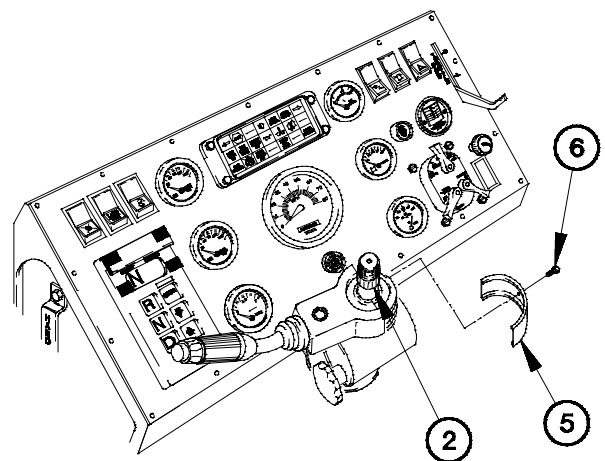

xa26I021.dwg

- (3) Route turn signal switch connectors (7 and 8) through opening (9) in dashboard (10).
- (4) Connect turn signal switch connectors (7 and 8) to connectors P18 (11) and J19 (12).

c. Follow-On Maintenance.

- (1) Install instrument panel assembly (para 7-15).
- (2) Check operation of turn signal switch (TM 9-2320-366-10-1).

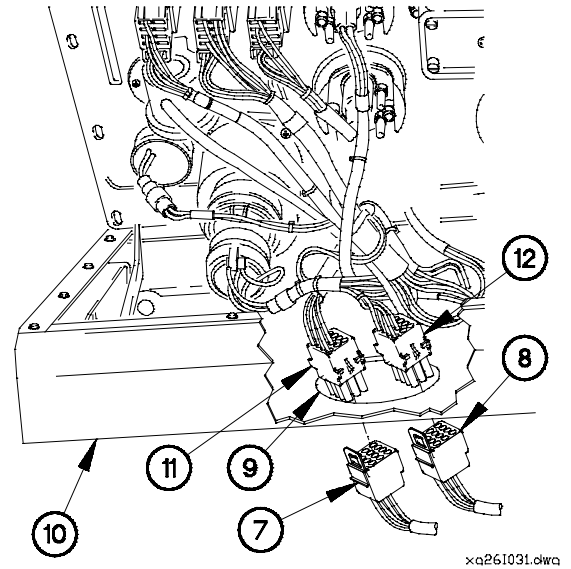

End of Task.

7-27. M1084/M1086 JUNCTION BOX ASSEMBLY REPLACEMENT/REPAIR

This task covers:

a. Removal	d. Installation
b. Disassembly	e. Follow-On Maintenance
c. Assembly	

INITIAL SETUP

<p>Equipment Conditions Crane erected (TM 9-2320-366-10-1). Engine shut down (TM 9-2320-366-10-1). Batteries disconnected (para 7-57).</p> <p>Tools and Special Tools Tool Kit, Genl Mech (Item 46, Appendix C) Goggles, Industrial (Item 15, Appendix C) Drill, Portable, Electric (Item 7, Appendix C) Drill Set, Twist (Item 6, Appendix C) Tool Kit, Blind Rivet (Item 44, Appendix C) Tool Kit, Electrical (Item 45, Appendix C) Wrench, Torque, 0-75 lb-in. (Item 90, Appendix B)</p>	<p>Materials/Parts Dispenser, Pressure Sensitive Adhesive Tape (Item 20, Appendix D) Insulation Sleeving, Electrical (Item 29, Appendix D) Varnish, Oil (Item 70, Appendix D) Ties, Cable, Plastic (Item 69, Appendix D) Nut, Conduit (3) (Item 124, Appendix G) Nut, Conduit (3) (Item 125, Appendix G) Lockwasher (4) (Item 94, Appendix G) Lockwasher (10) (Item 91, Appendix G) Lockwasher (12) (Item 92, Appendix G) Rivet, Blind (Item 255, Appendix G) Lockwasher (Item 93, Appendix G) Modification Kit, Junction Box (Item 31.1, Appendix D) Rag, Wiping (Item 50, Appendix D)</p>
---	---

a. Removal.

NOTE

Remove plastic cable ties as required.

- (1) Loosen four screws (1) on junction box (2).
- (2) Open cover (3) on junction box (2).

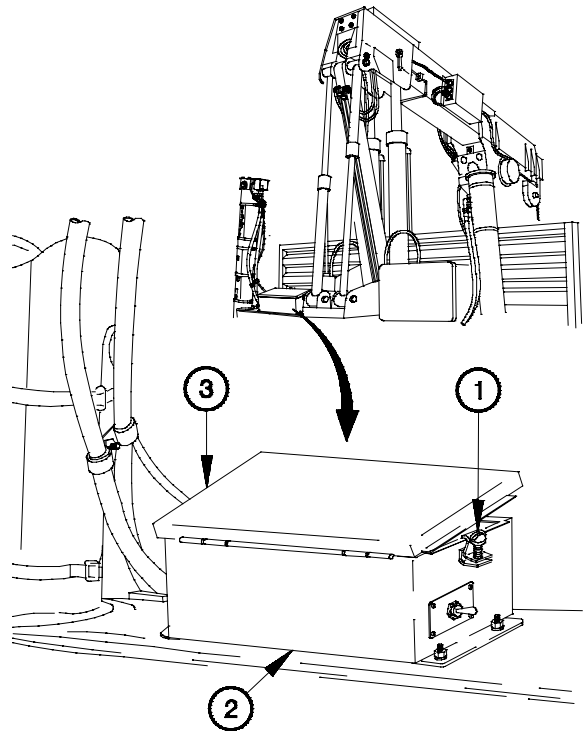

4G27A011

NOTE

Tag wires and connection points prior to disconnecting.

- (3) Disconnect quick disconnect terminal (4) from ground strip (5) position 17.
- (4) Remove two screws (6) from terminal block (7) positions 6 and 11.

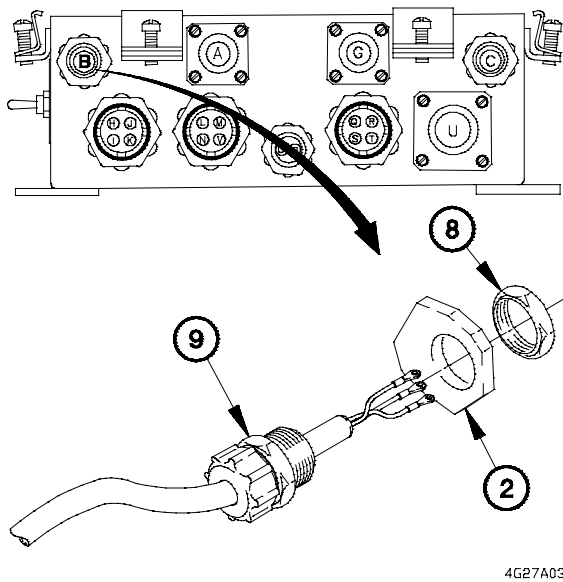
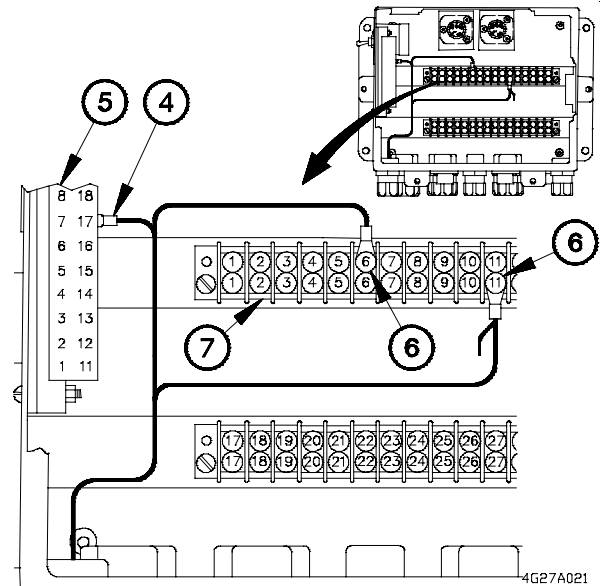

- (5) Remove conduit nut (8) and right jack cylinder proximity sensor cable (9) from junction box (2). Discard conduit nut.

- (6) Disconnect quick disconnect terminal (10) from ground strip (5) position 14.
- (7) Remove three screws (11) from terminal blocks (7) and (12) positions 6, 25, and 28.

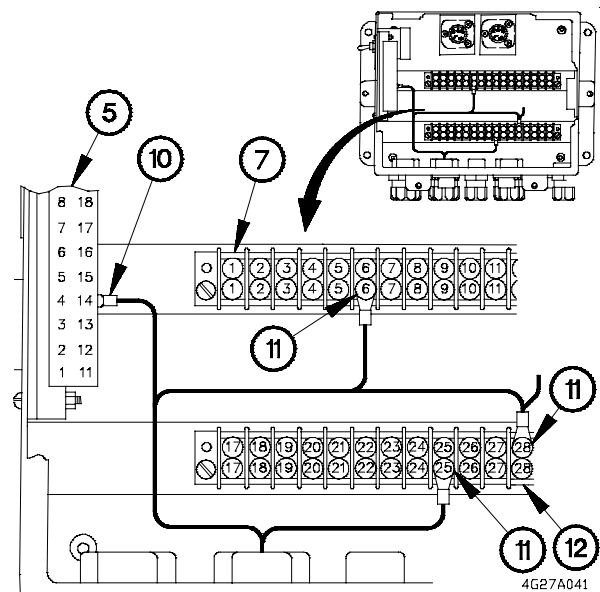

7-27. M1084/M1086 JUNCTION BOX ASSEMBLY REPLACEMENT/REPAIR (CONT)

(8) Remove four nuts (13), lockwashers (14), screws (15), and overload lockout cable (16) from junction box (2). Discard lockwashers.

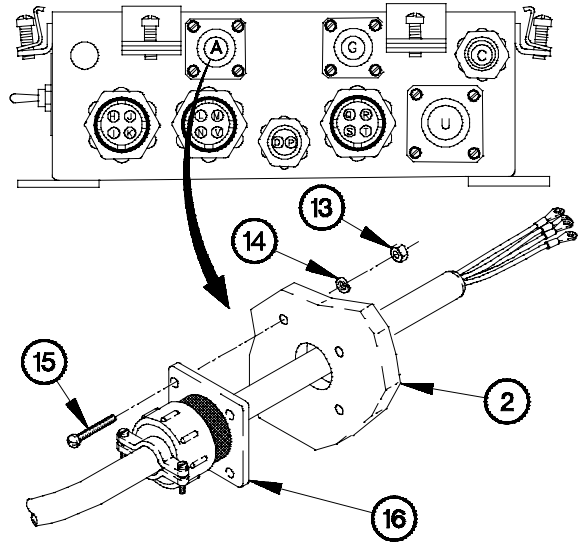

4G27A051

(9) Disconnect quick disconnect terminal (17) from ground strip (5) position 18.

(10) Remove three screws (18) from terminal block (7) positions 3, 4, and 5.

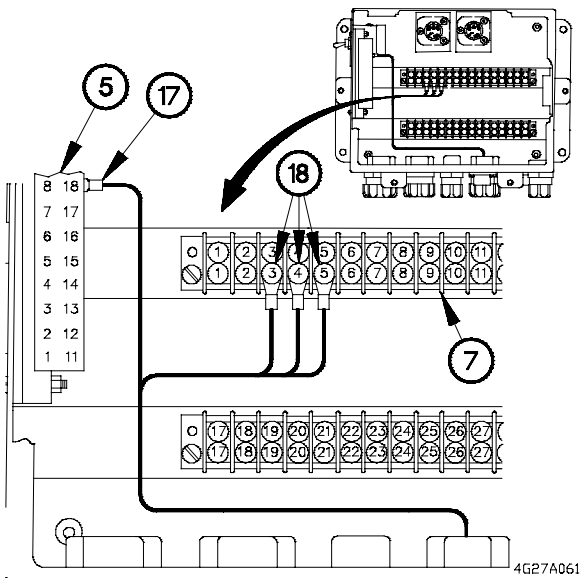

4G27A061

(11) Remove four nuts (19), lockwashers (20), screws (21), and crane power cable (22) from junction box (2). Discard lockwashers.

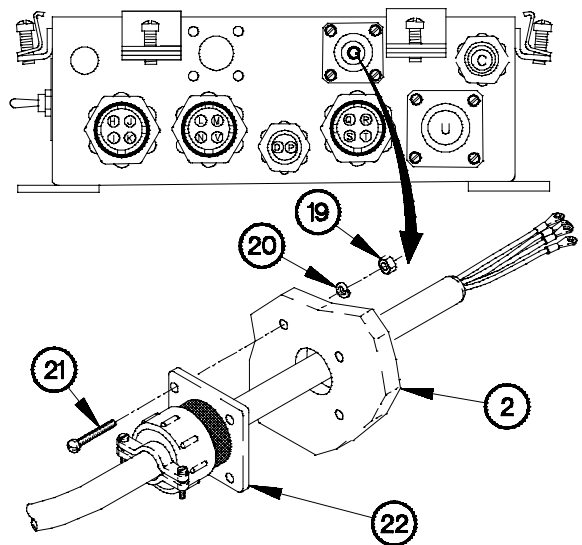

4G27A071

(12) Disconnect quick disconnect terminal (23) from ground strip (5) position 16.

(13) Remove screw (24) from terminal block (7) position 10.

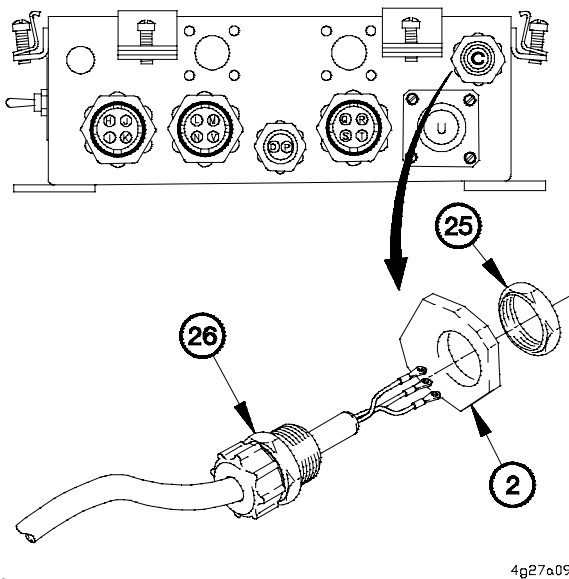
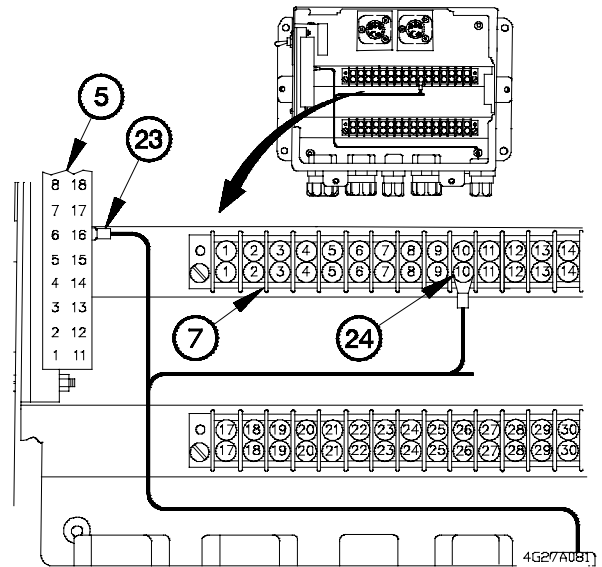

(14) Remove conduit nut (25) and left jack cylinder proximity sensor cable (26) from junction box (2). Discard conduit nut.

(15) Disconnect quick disconnect terminal (27) from ground strip (5) position 15.

(16) Remove two screws (28) from terminal block (7) positions 9 and 14.

(17) Remove ten screws (29) from terminal block (12) positions 17 through 26.

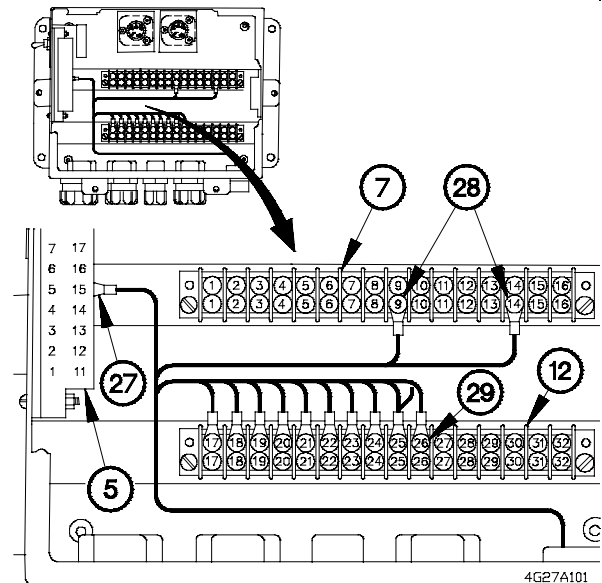

7-27. M1084/M1086 JUNCTION BOX ASSEMBLY REPLACEMENT/REPAIR (CONT)

- (18) Remove four nuts (30), lockwashers (31), screws (32), and remote control cable (33) from junction box (2). Discard lockwashers.

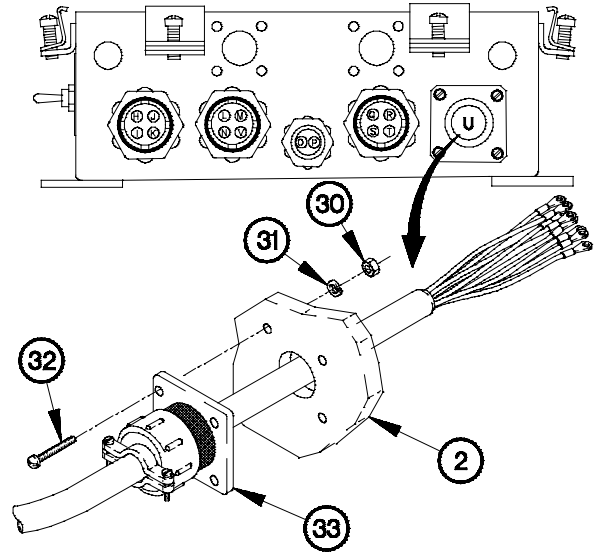

4G27A111

- (19) Disconnect four quick disconnect terminals (34) from ground strip (5) positions 6, 7, 9, and 10.
- (20) Remove four screws (35) from terminal block (12) positions 21 through 24.

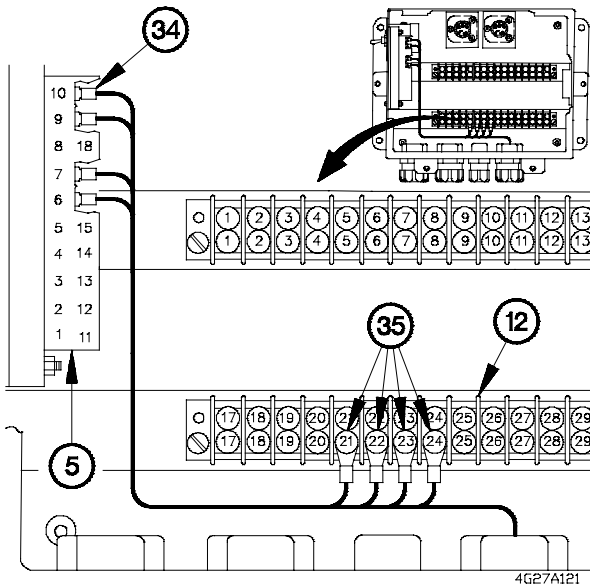

4G27A121

- (21) Remove conduit nut (36) and hoist up solenoid, hoist down solenoid, boom up solenoid, and boom down solenoid cable assembly (37) from junction box (2). Discard conduit nut.

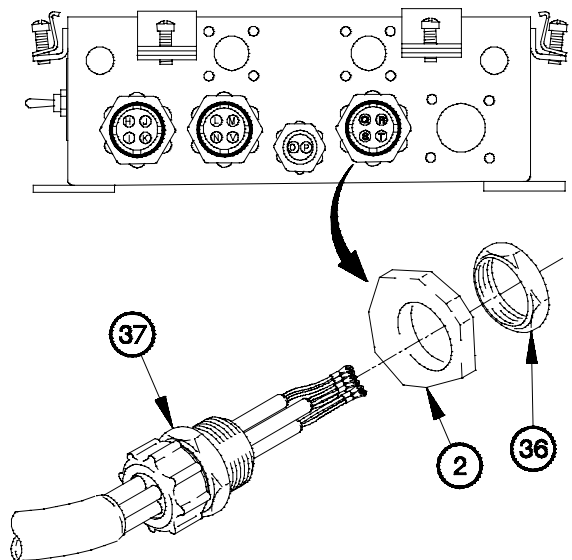

4G27A131

- (22) Disconnect two quick disconnect terminals (38) from ground strip (5) positions 2 and 8.
- (23) Remove two screws (39) from terminal blocks (7) and (12) positions 12 and 28.

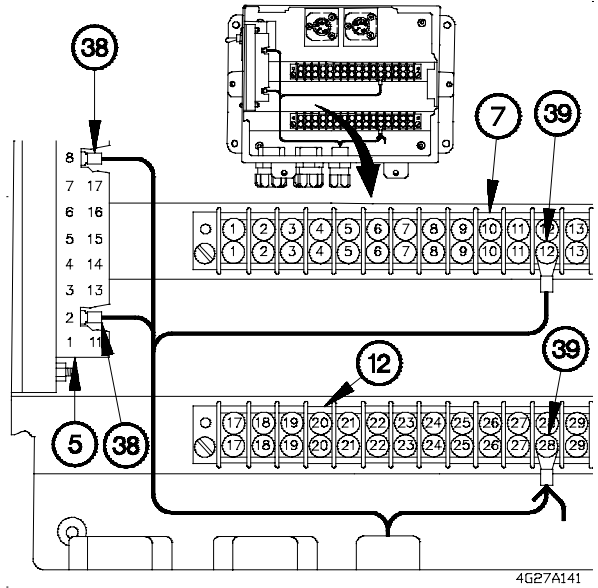

4G27A141

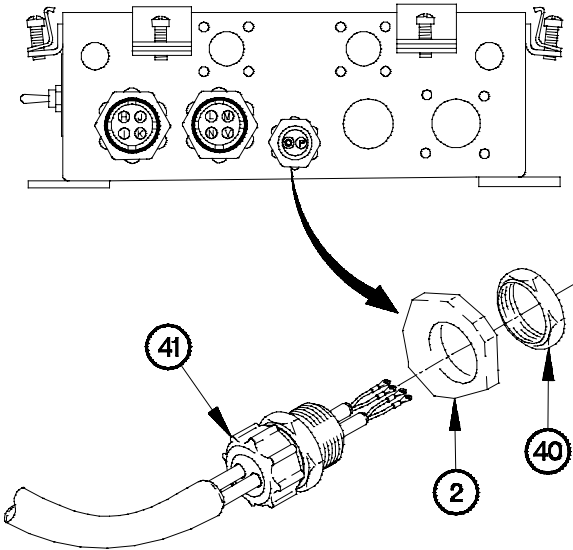

4G27A151

- (24) Remove conduit nut (40) and system shutdown solenoid and boom up lockout solenoid cable assembly (41) from junction box (2). Discard conduit nut.

- (25) Disconnect four quick disconnect terminals (42) from ground strip (5) positions 4, 5, 11, and 12.
- (26) Remove screw (43) from terminal block (7) position 8.

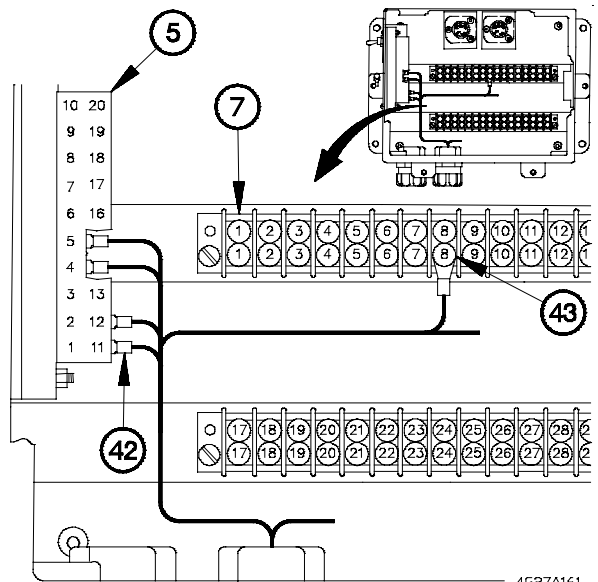

4G27A161

7-27. M1084/M1086 JUNCTION BOX ASSEMBLY REPLACEMENT/REPAIR (CONT)

(27) Remove conduit nut (44) and telescope out lockout solenoid, hoist up lockout solenoid, control lockout solenoid, and boom down lockout solenoid cable assembly (45) from junction box (2). Discard conduit nut.

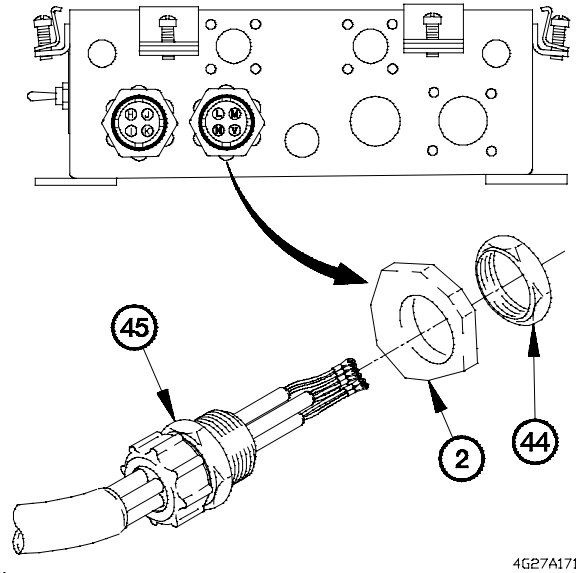

(28) Disconnect three quick disconnect terminals (46) from ground strip (5) positions 1, 3, and 13.

(29) Remove five screws (47) from terminal block (12) positions 17 through 21.

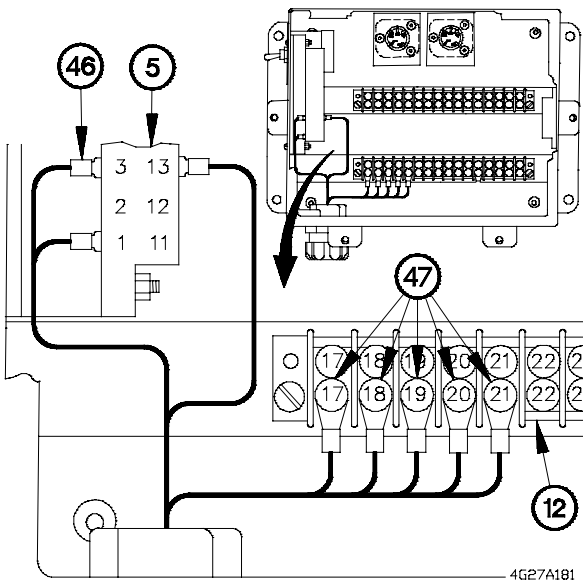

(30) Remove conduit nut (48) and telescope in solenoid, telescope out solenoid, swing CCW solenoid, and swing CW solenoid cable assembly (49) from junction box (2). Discard conduit nut.

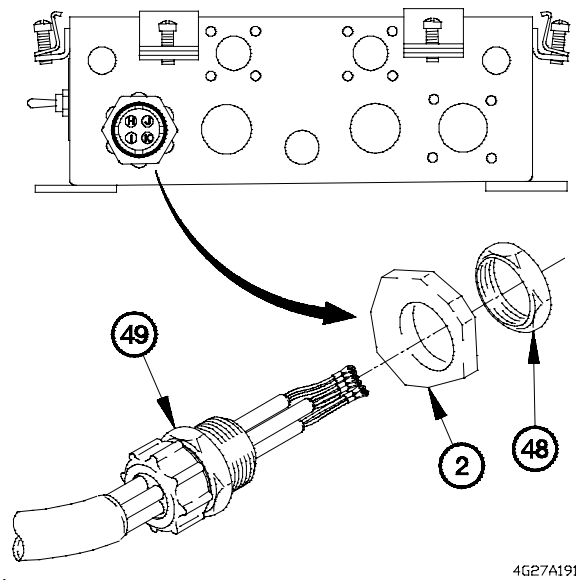

- (31) Remove nut (50), terminal lug (51), lockwasher (52), and washer (53) from mounting stud (54). Discard lockwasher.
- (32) Remove three nuts (50), lockwashers (52), washers (53), and junction box (2) from mounting studs (54). Discard lockwashers.

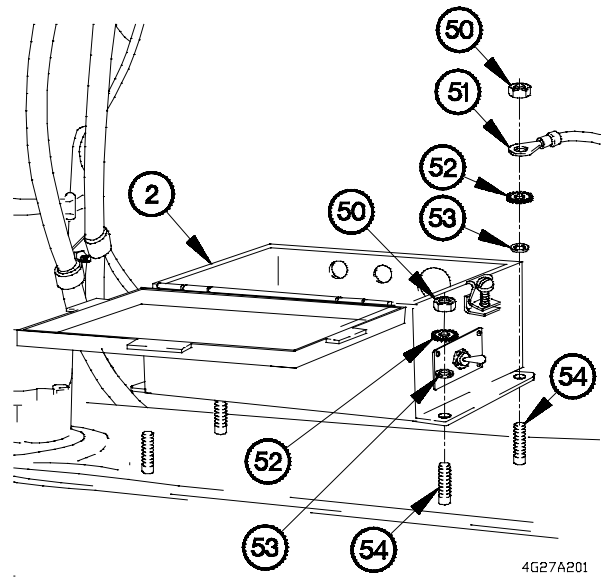

b. Disassembly.

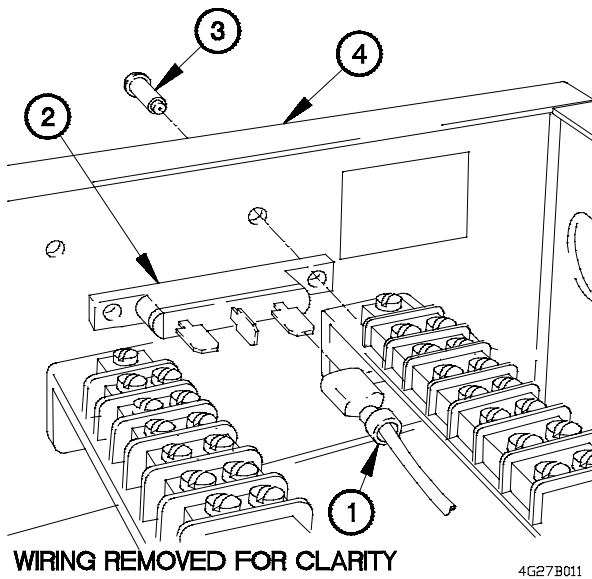

NOTE

Tag wires and connection points prior to removing.

- (1) Disconnect three quick disconnect terminals (1) from diode assembly (2).

WARNING

Wear appropriate eye protection when removing rivets. Failure to comply may result in injury to personnel.

- (2) Remove two rivets (3) and diode assembly (2) from junction box (4).

7-27. M1084/M1086 JUNCTION BOX ASSEMBLY REPLACEMENT/REPAIR (CONT)

NOTE

Perform steps (3) through (6) on junction boxes that have not had modification kit installed.

- (3) Unsolder five wires (5) from lockout relay (6).
- (4) Unsolder five wires (7) from shutdown relay (8).

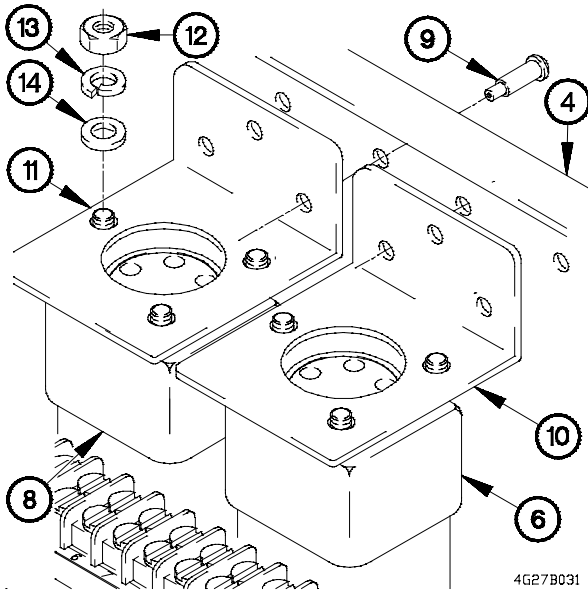
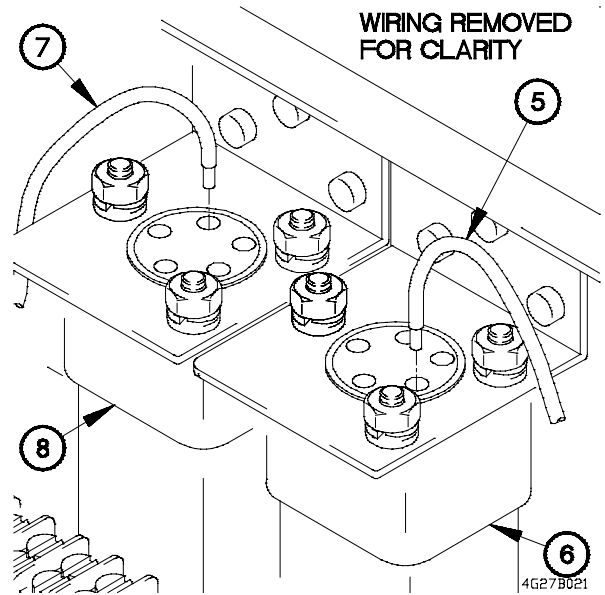

WARNING

Wear appropriate eye protection when removing rivets. Failure to comply may result in injury to personnel.

- (5) Remove six rivets (9) and brackets (10 and 11) from junction box (4).
- (6) Remove six nuts (12), lockwashers (13), washers (14) and brackets (10 and 11) from shutdown relay (8) and lockout relay (6). Discard lockwashers.

NOTE

Perform steps (6.1) through (6.4) on junction boxes that have modification kit installed.

- (6.1) Disconnect shutdown relay connector (14.1) from shutdown relay (14.2).
- (6.2) Disconnect lockout relay connector (14.3) from lockout relay (14.4).
- (6.3) Remove nut (14.5), lockwasher (14.6), washer (14.7), shutdown relay (14.2), lockout relay (14.4) and screw (14.8) from bracket (14.9). Discard lockwasher.

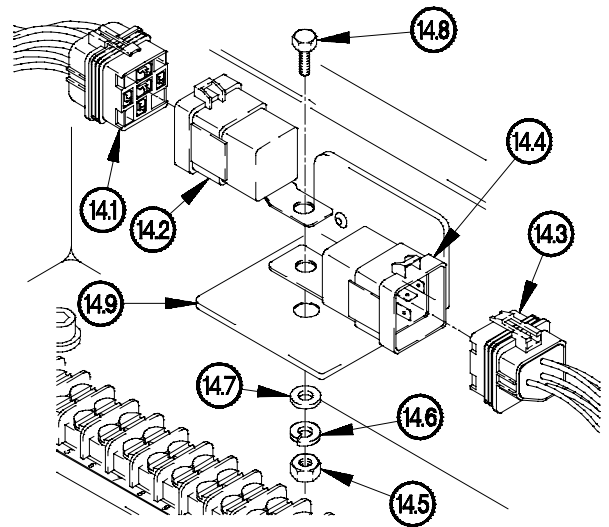

4G27B04B

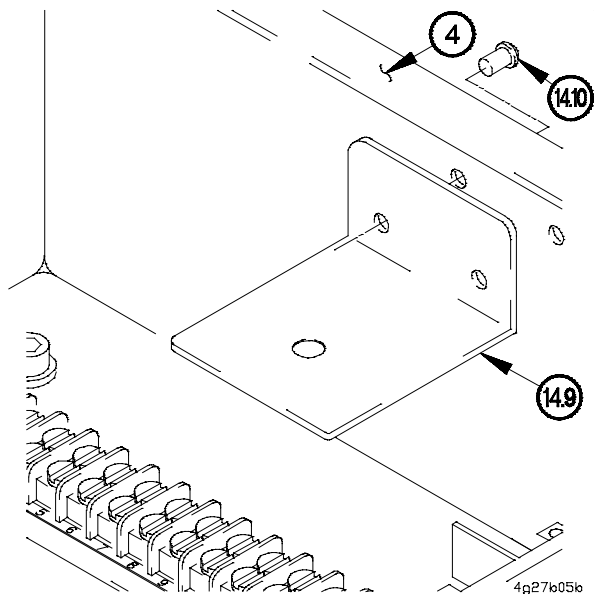

4g27b05b

WARNING

Wear appropriate eye protection when removing rivets. Failure to comply may result in injury to personnel.

- (6.4) Remove two rivets (14.10) and bracket (14.9) from junction box (4).

- (7) Disconnect two quick disconnect terminals (15) from ground strip (16) positions 19 and 20.
- (8) Remove two nuts (17), lockwashers (18), washers (19), nylon washers (20), screws (21), and ground strip (16) from junction box (4). Discard lockwashers.

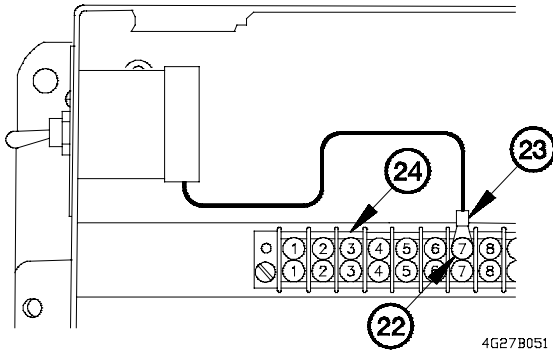
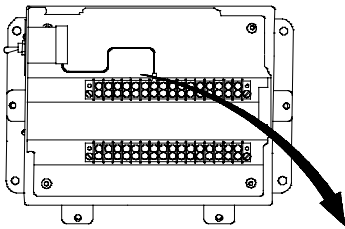
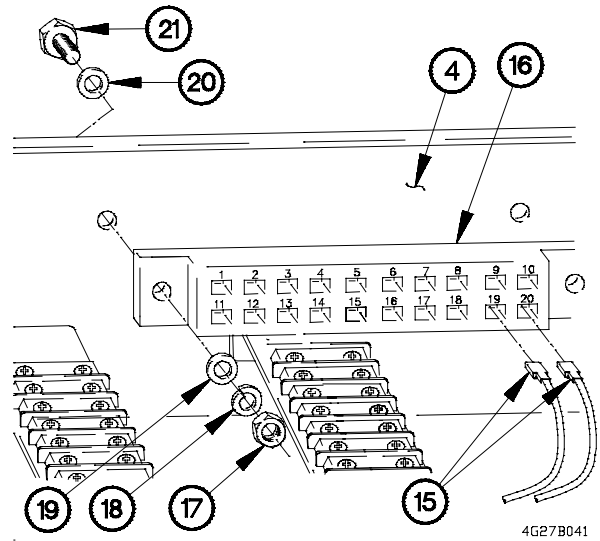

- (9) Remove screw (22) and terminal lug (23) from terminal block (24) position 7.

- (10) Remove nut (25), lockwasher (26), washer (27), and circuit breaker (28) from junction box (4). Discard lockwasher.

WARNING

Wear appropriate eye protection when removing rivets. Failure to comply may result in injury to personnel.

- (11) Remove four rivets (29) and panel (30) from junction box (4).

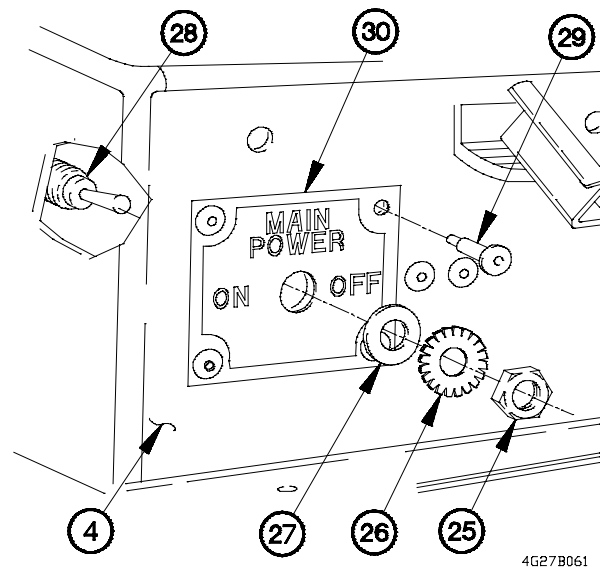

7-27. M1084/M1086 JUNCTION BOX ASSEMBLY REPLACEMENT/REPAIR (CONT)

NOTE

Remove plastic cable ties as required.

- (12) Remove seven screws (31) and terminal lugs (32) from terminal block (22) positions 5, 8, 9, 10, 12, 13 and 14.
- (13) Remove screw (33) and terminal lug (34) from terminal block (22) position 7.

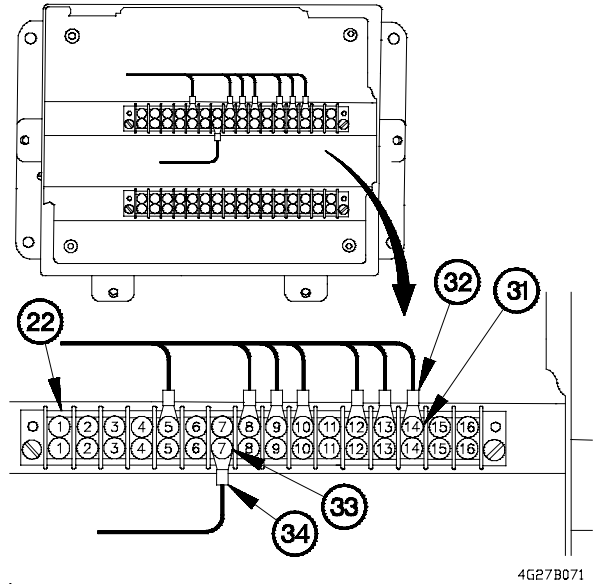

4G27B071

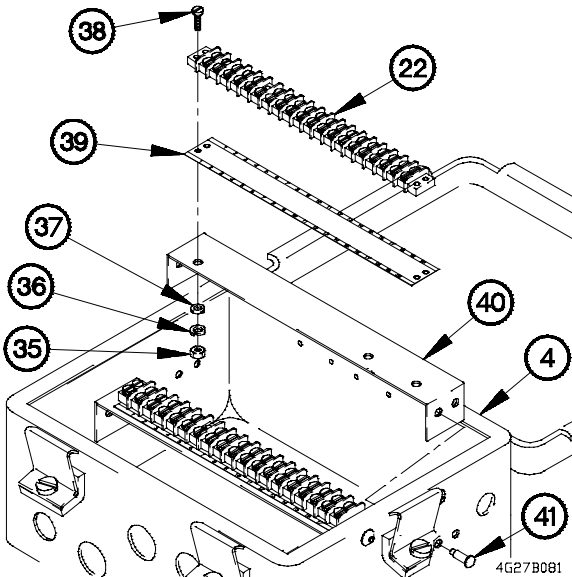

4G27B081

- (14) Remove two nuts (35), lockwashers (36), washers (37), screws (38), decal (39), and terminal block (22) from bracket (40). Discard lockwashers.

WARNING

Wear appropriate eye protection when removing rivets. Failure to comply may result in injury to personnel.

- (15) Remove four rivets (41) and bracket (40) from junction box (4).

- (16) Remove two nuts (42), lockwashers (43), washers (44), screws (45), decal (46), and terminal block (47) from bracket (48). Discard lockwashers.

WARNING

Wear appropriate eye protection when removing rivets. Failure to comply may result in injury to personnel.

- (17) Remove four rivets (49) and bracket (48) from junction box (4).

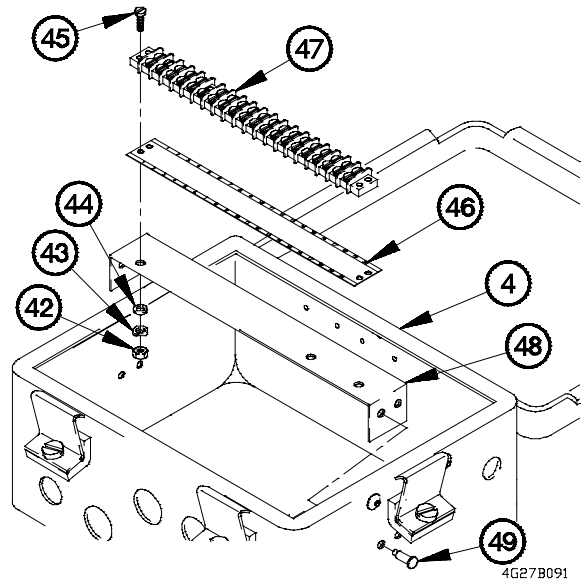

c. Assembly.

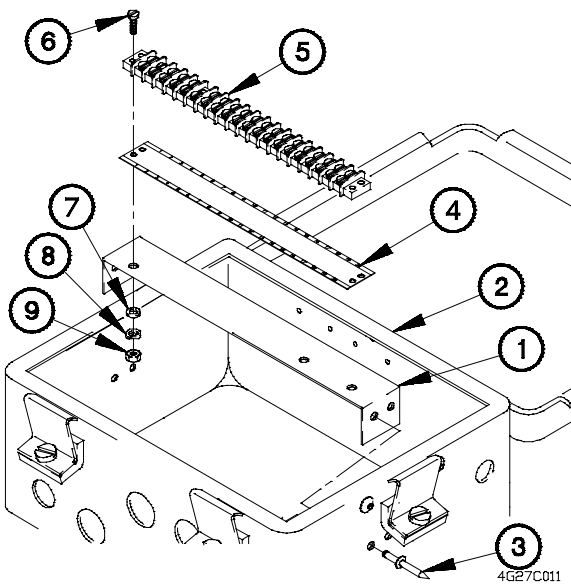

- (1) Install bracket (1) on junction box (2) with four rivets (3).
- (2) Install decal (4) and terminal block (5) on bracket (1) with two screws (6), washers (7), lockwashers (8) and nuts (9).

- (3) Install bracket (10) on junction box (2) with four rivets (11).
- (4) Install decal (12) and terminal block (13) on bracket (10) with two screws (14), washers (15), lockwashers (16), and nuts (17).

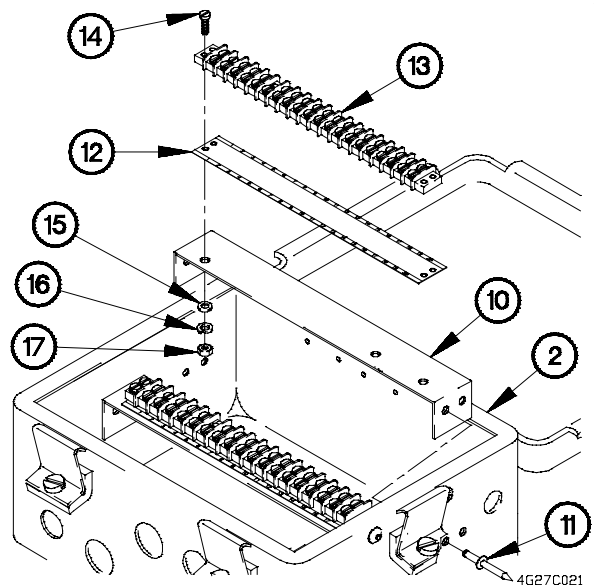

7-27. M1084/M1086 JUNCTION BOX ASSEMBLY REPLACEMENT/REPAIR (CONT)

- (5) Install terminal lug (18) on terminal block (5) position 7 with screw (19).
- (6) Install seven terminal lugs (20) on terminal block (5) positions 5, 8, 9, 10, 12, 13, and 14 with seven screws (21).

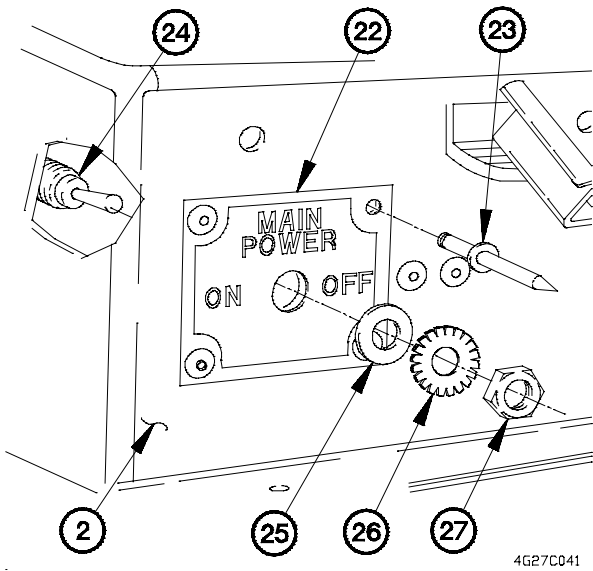
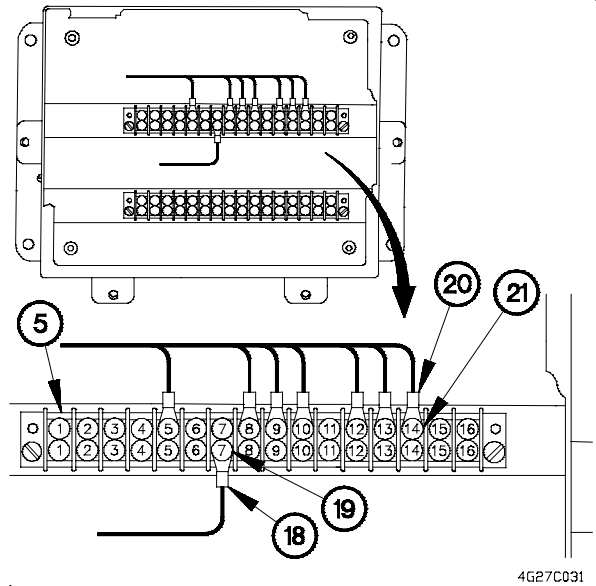

- (7) Install panel (22) on junction box (2) with four rivets (23).
- (8) Install circuit breaker (24) on junction box (2) with washer (25), lockwasher (26), and nut (27).
- (9) Tighten nut (27) to 25 lb-in. (3 N·m).

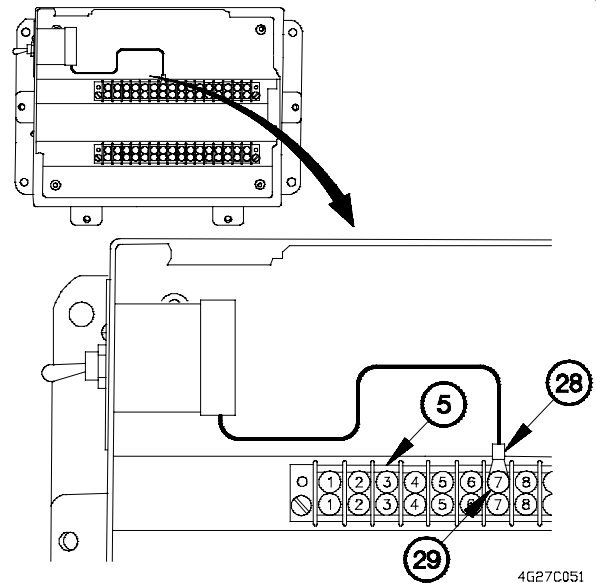

- (10) Install terminal lug (28) on terminal block (5) position 7 with screw (29).

- (11) Install ground strip (30) on junction box (2) with two screws (31), nylon washers (32), washers (33), lockwashers (34), and nuts (35).
- (12) Connect two quick disconnect terminals (36) to ground strip (30) positions 19 and 20.

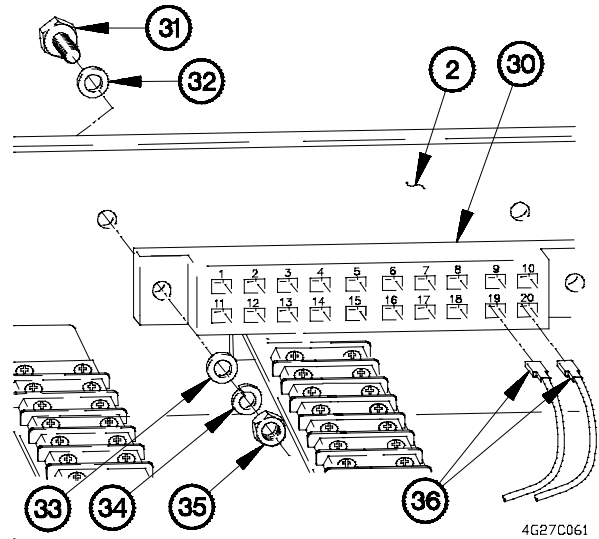

4G27C061

NOTE

Perform steps (12.1) through (12.4) on junction boxes that have had modification kit installed.

- (12.1) Install lockout relay (36.1) and shutdown relay (36.2) on bracket (36.3) with screw (36.4), washer (36.5), lockwasher (36.6), and nut (36.7).
- (12.2) Connect lockout relay connector (36.8) to lockout relay (36.1).
- (12.3) Connect shutdown relay connector (36.9) to shutdown relay (36.2).

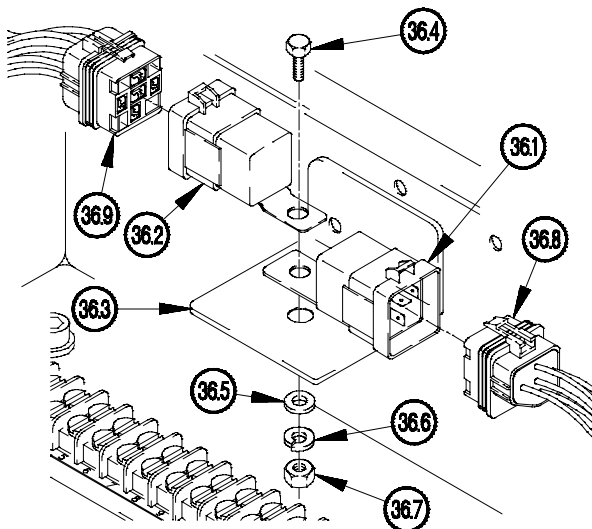

4G27C07B

- (12.4) Install bracket (36.3) on junction box (2) with two rivets (36.10).

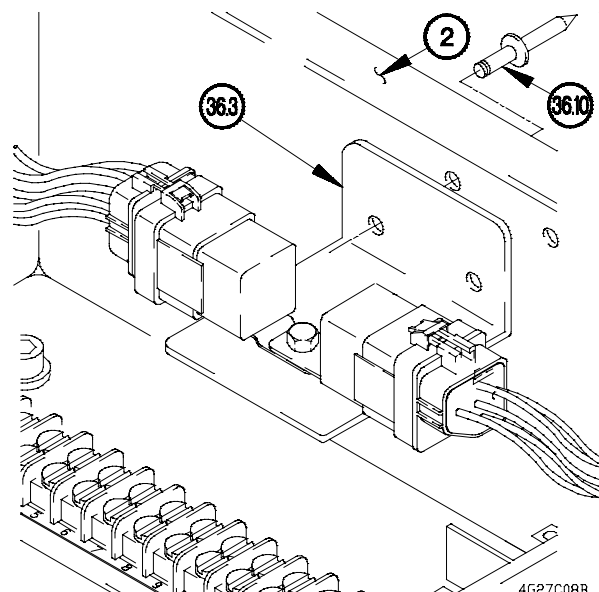

4G27C08B

NOTE

Perform steps (13) through (16) on junction boxes that have not had modification kit installed.

- (13) Install lockout relay (37) and shutdown relay (38) on brackets (39 and 40) with six washers (41), lockwashers (42), and nuts (43).
- (14) Install brackets (39 and 40) in junction box (2) with six rivets (44).

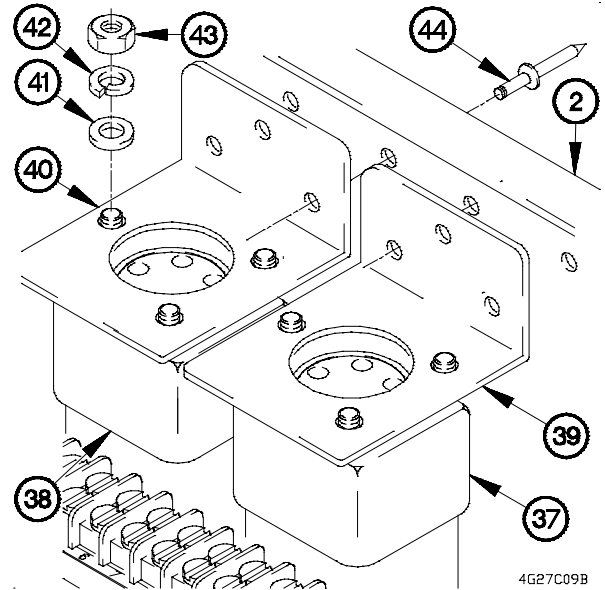

WIRING REMOVED FOR CLARITY

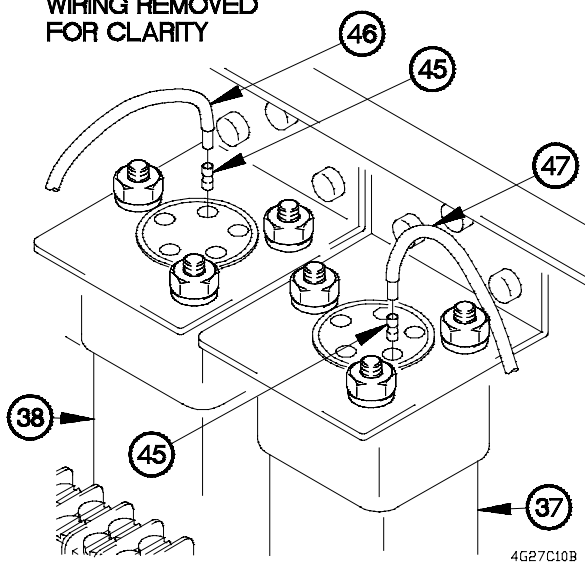

- (15) Install shrink tubing (45) over ends of five wires (46) and solder ends on shutdown relay (38) positions 1 through 5.
- (16) Install shrink tubing (45) over ends of five wires (47) and solder ends on lockout relay (37) positions 1 through 5.

7-27. M1084/M1086 JUNCTION BOX ASSEMBLY REPLACEMENT/REPAIR (CONT)

- (17) Install diode assembly (48) on junction box (2) with two rivets (49).
- (18) Connect three quick disconnect terminals (50) to diode assembly (48).
- (19) Apply varnish to three quick disconnect terminals (50).

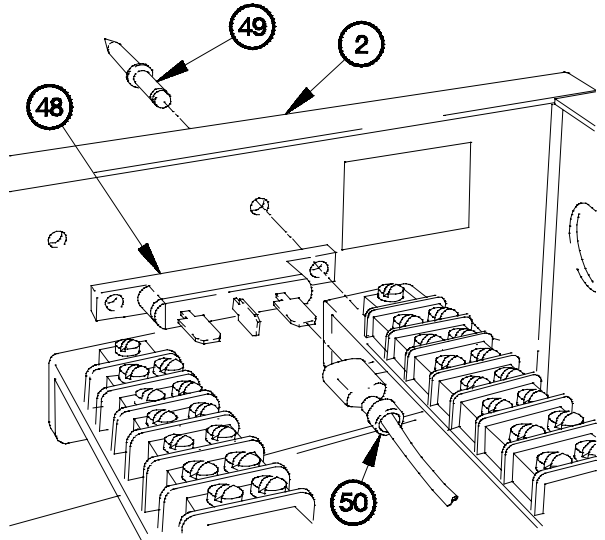

4G27C091

d. Installation.

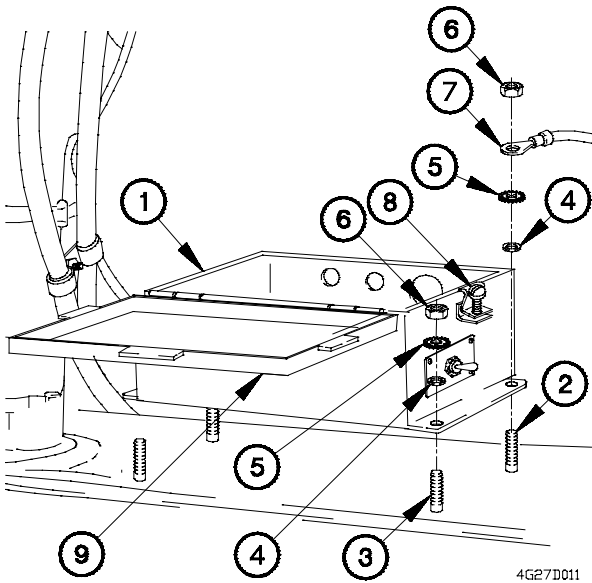

4G27D011

- (1) Install junction box (1) on mounting stud (2) and three mounting studs (3) with three washers (4), lockwashers (5), and nuts (6).
- (2) Install washer (4), lockwasher (5), and terminal lug (7) on mounting stud (2) with nut (6).
- (3) Loosen four screws (8) on junction box (1).
- (4) Open cover (9) on junction box (1).

- (5) Install telescope in solenoid, telescope out solenoid, swing CCW solenoid, and swing CW solenoid cable assembly (10) in junction box (1) with conduit nut (11).

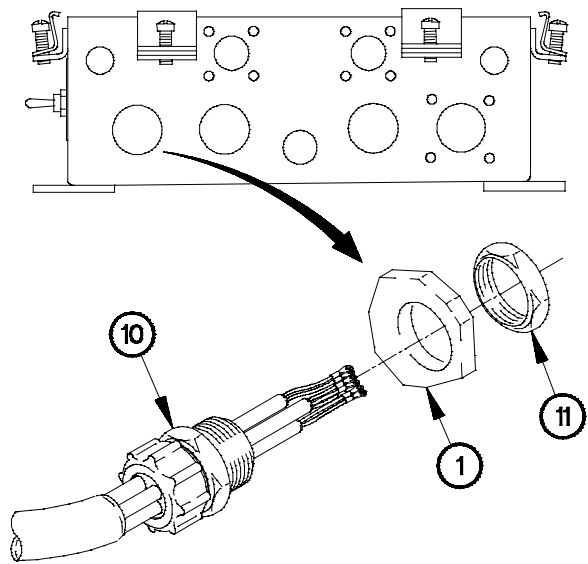

4G27D021

- (6) Connect three quick disconnect terminals (12) to ground strip (13) positions 1, 3, and 13.
- (7) Install five terminal lugs (14) on terminal block (15) positions 17 through 21 with five screws (16).

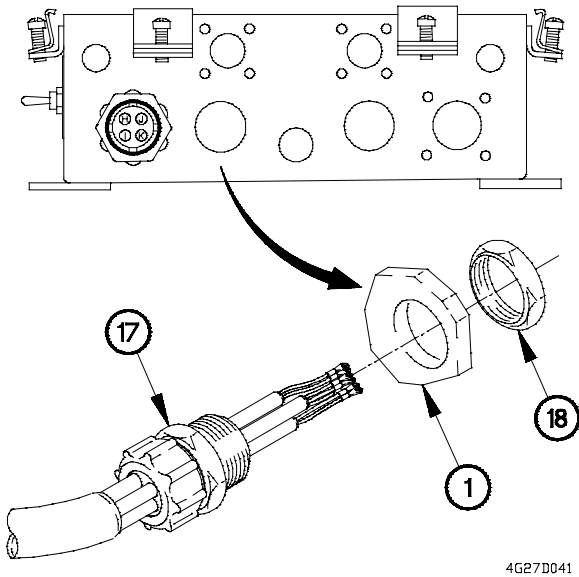
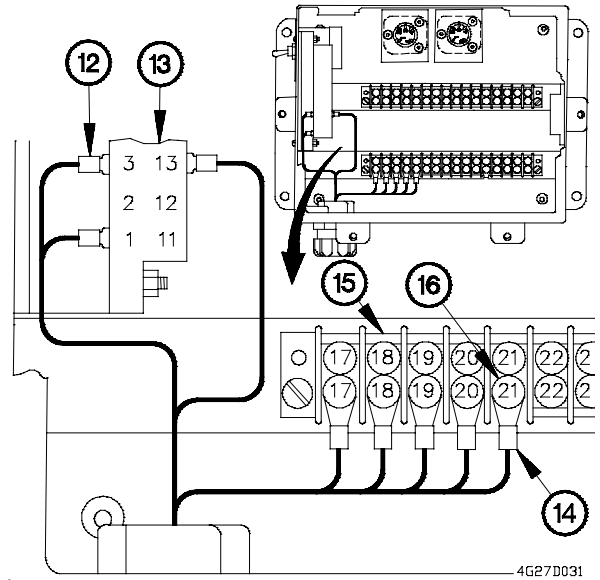

- (8) Install telescope out lockout solenoid, hoist up lockout solenoid, control lockout solenoid, and boom down lockout solenoid cable assembly (17) in junction box (1) with conduit nut (18).

- (9) Connect four quick disconnect terminals (19) to ground strip (13) positions 4, 5, 11, and 12.
- (10) Install terminal lug (20) on terminal block (21) position 8 with screw (22).

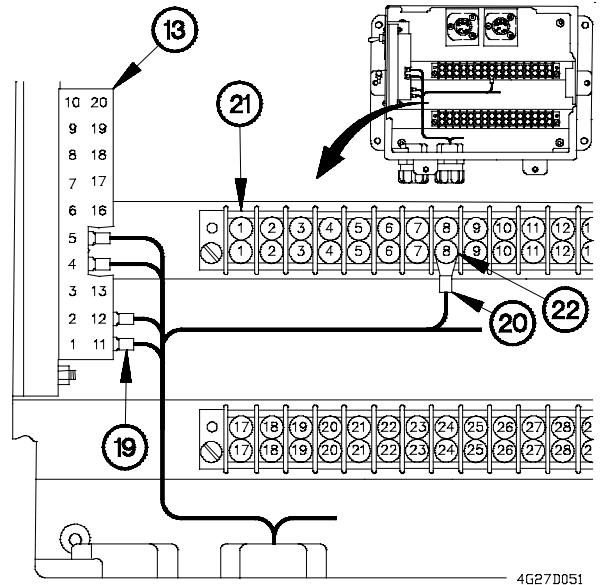

7-27. M1084/M1086 JUNCTION BOX ASSEMBLY REPLACEMENT/REPAIR (CONT)

(11) Install system shutdown solenoid and boom up lockout solenoid cable assembly (24) in junction box (1) conduit nut (25).

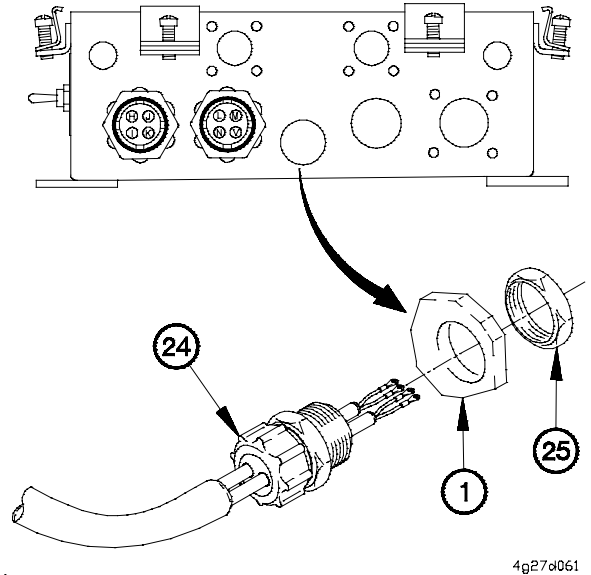

4g27d061

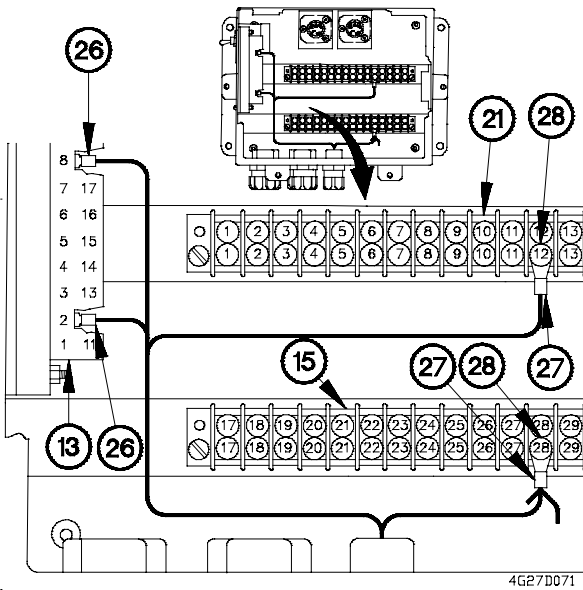

4G27D071

(12) Connect two quick disconnect terminals (26) to ground strip (13) positions 8 and 2.

(13) Install two terminal lugs (27) on terminal block (15) position 28 and terminal block (21) position 12 with two screws (28).

(14) Install hoist up solenoid, hoist down solenoid, boom up solenoid, and boom down solenoid cable assembly (29) in junction box (1) with conduit nut (30).

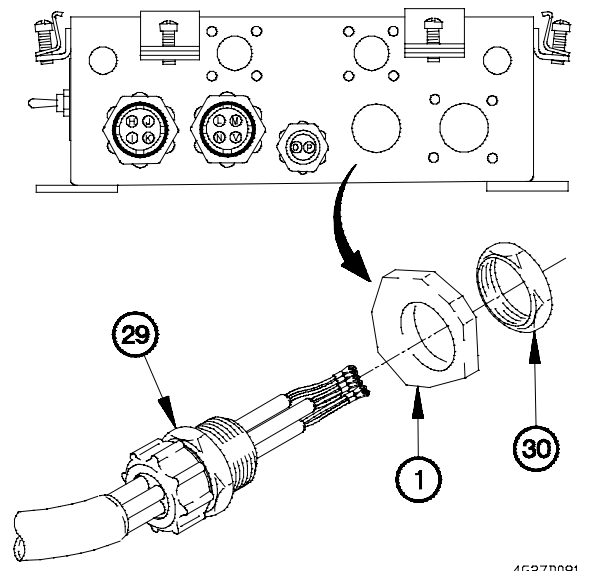

4G27D081

- (15) Connect four quick disconnect terminals (31) to ground strip (13) positions 6, 7, 9, and 10.
- (16) Install four terminal lugs (32) on terminal block (15) positions 21 through 24 with four screws (33).

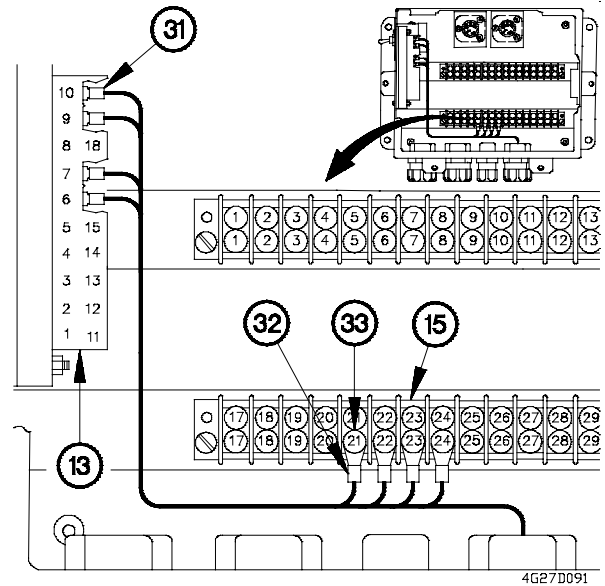

4G27D091

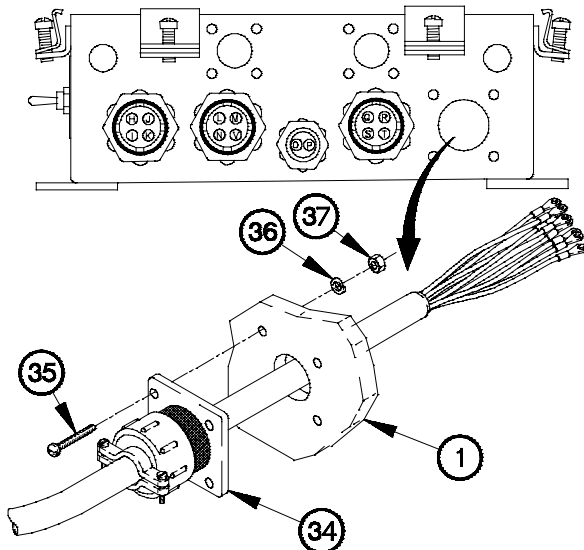

4G27D101

- (17) Install remote control cable (34) in junction box (1) with four screws (35), lockwashers (36), and nuts (37).

- (18) Connect quick disconnect terminal (38) to ground strip (13) position 15.
- (19) Install 12 terminal lugs (39) on terminal block (15) positions 17 through 26 and terminal block (21) positions 9 and 14 with 12 screws (40).

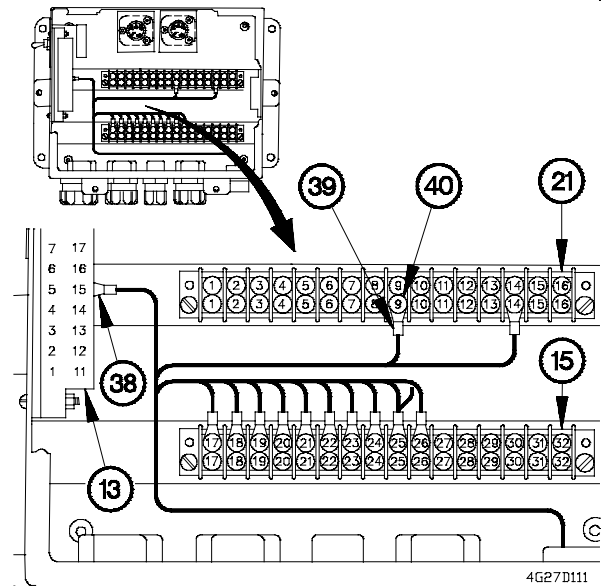

4G27D111

7-27. M1084/M1086 JUNCTION BOX ASSEMBLY REPLACEMENT/REPAIR (CONT)

(20) Install left proximity sensor cable (41) in junction box (1) with conduit nut (42).

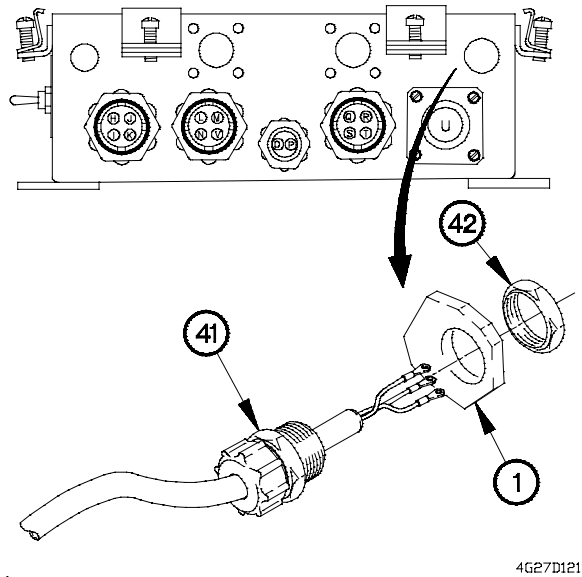

4G27D121

(21) Connect quick disconnect terminal (43) to ground strip (13) position 16.

(22) Install terminal lug (44) on terminal block (21) position 10 with screw (45).

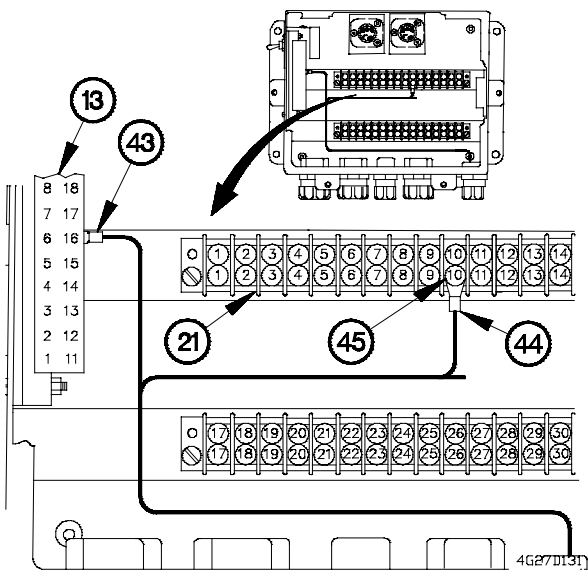

4G27D131

(23) Install crane power cable (46) in junction box (1) with four screws (47), lockwashers (48), and nuts (49).

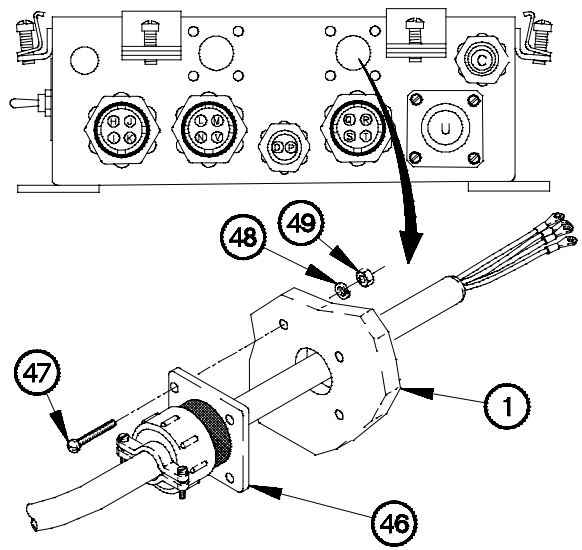

4G27D141

- (24) Connect quick disconnect terminal (50) to ground strip (13) position 18.
- (25) Install three terminal lugs (51) on terminal block (21) positions 3, 4, and 5 with three screws (52).

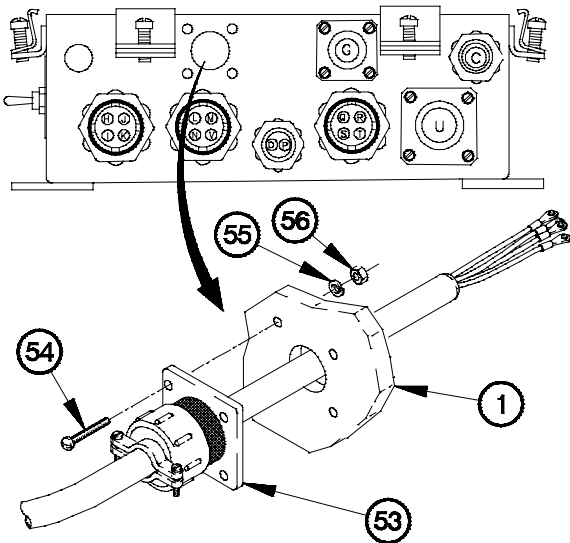
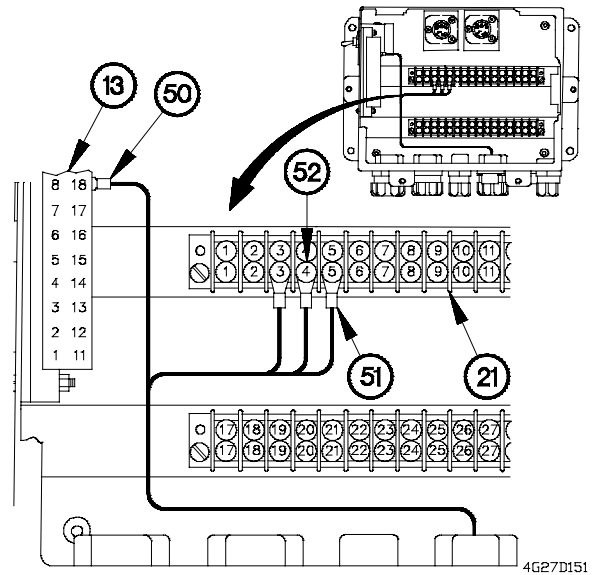

- (26) Install overload lockout cable (53) in junction box (1) with four screws (54), lockwashers (55), and nuts (56).

- (27) Connect quick disconnect terminal (57) on ground strip (13) position 14.
- (28) Install three terminal lugs (58) on terminal block (15) position 25 and 28 and terminal block (21) position 6 with three screws (59).

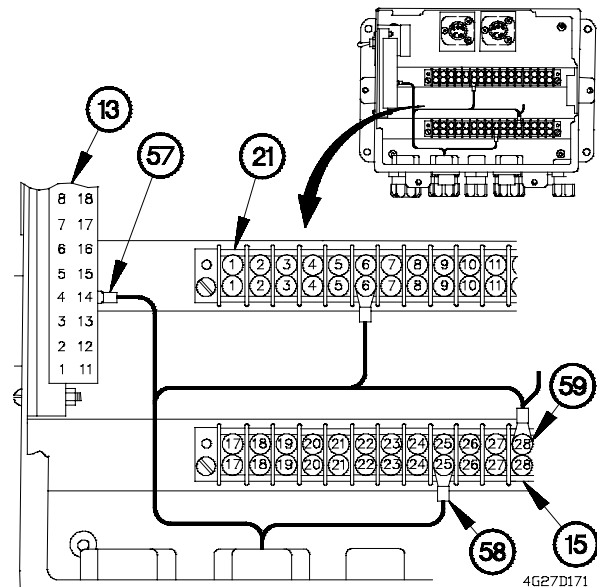

7-27. M1084/M1086 JUNCTION BOX ASSEMBLY REPLACEMENT/REPAIR (CONT)

(29) Install right proximity sensor cable (60) in junction box (1) with conduit nut (61).

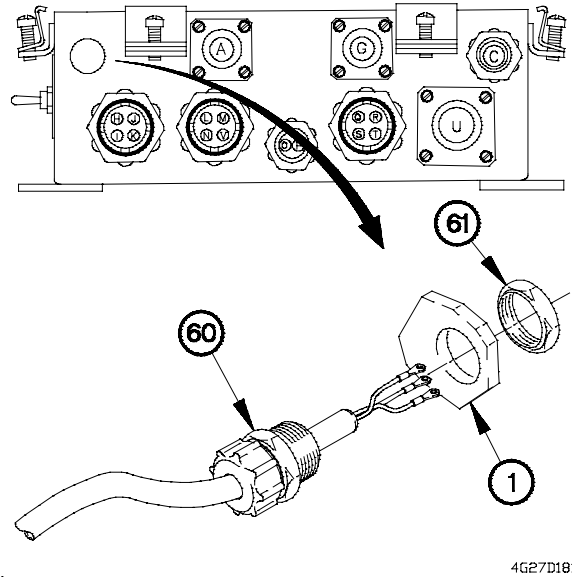

4G27D181

(30) Connect quick disconnect terminal (62) to ground strip (13) position 17.

(31) Install two terminal lugs (63) on terminal block (21) position 6 and 11 with two screws (64).

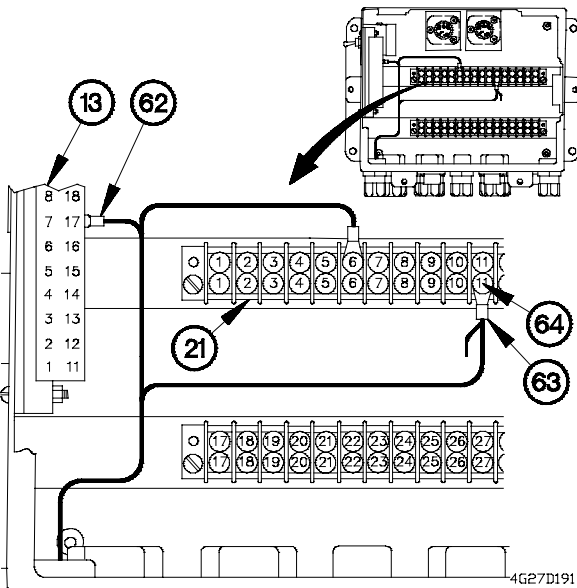

4G27D191

(32) Close cover (9) on junction box (1).

(33) Tighten four screws (8) on junction box (1).

e. Follow-On Maintenance.

(1) Connect batteries (para 7-57).

(2) Operate crane and check all crane functions (TM 9-2320-366-10-1).

End of Task.

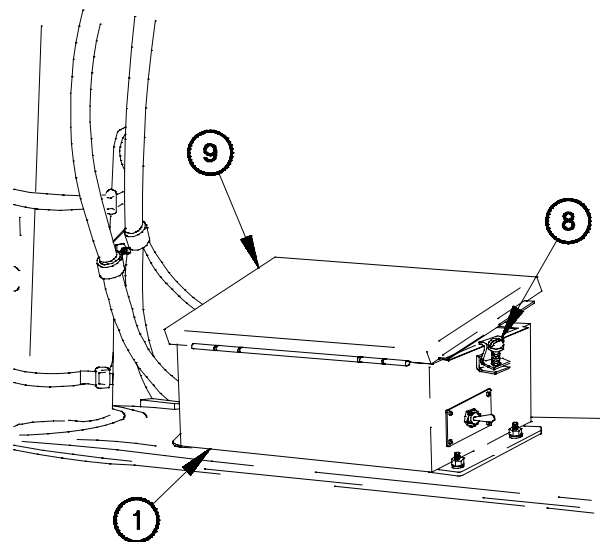

4G27D201

7-28. M1089 JUNCTION BOX ASSEMBLY REPLACEMENT/REPAIR

This task covers:

- a. Removal
- b. Disassembly
- c. Assembly
- d. Installation
- e. Follow-On Maintenance

INITIAL SETUP

Equipment Conditions

- Crane erected (TM 9-2320-366-10-1).
- Engine shut down (TM 9-2320-366-10-1).
- Batteries disconnected (para 7-57).

Tools and Special Tools

- Tool Kit, Genl Mech (Item 46, Appendix C)
- Goggles, Industrial (Item 15, Appendix C)
- Drill, Portable, Electric (Item 7, Appendix C)
- Drill, Set Twist (Item 6, Appendix C)
- Tool Kit, Blind Rivet (Item 44, Appendix C)
- Tool Kit, Electrical (Item 45, Appendix C)

Materials/Parts

- Dispenser, Pressure Sensitive Adhesive Tape (Item 20, Appendix D)
- Insulation Sleeving, Electrical (Item 29, Appendix D)
- Ties, Cable, Plastic (Item 69, Appendix D)
- Varnish, Oil (Item 70, Appendix D)
- Adhesive (Item 5, Appendix D)
- Nut, Conduit (3) (Item 124, Appendix G)
- Nut, Conduit (2) (Item 125, Appendix G)
- Lockwasher (16) (Item 91, Appendix G)
- Lockwasher (4) (Item 94, Appendix G)
- Lockwasher (Item 92, Appendix G)
- Rivet, Blind (Item 255, Appendix G)
- Lockwasher (Item 93, Appendix G)
- Modification Kit, Junction Box (Item 31.1, Appendix D)
- Rag, Wiping (Item 50, Appendix D)

a. Removal.

NOTE

Remove plastic cable ties as required.

- (1) Loosen four screws (1) on junction box (2).
- (2) Open cover (3) on junction box (2).

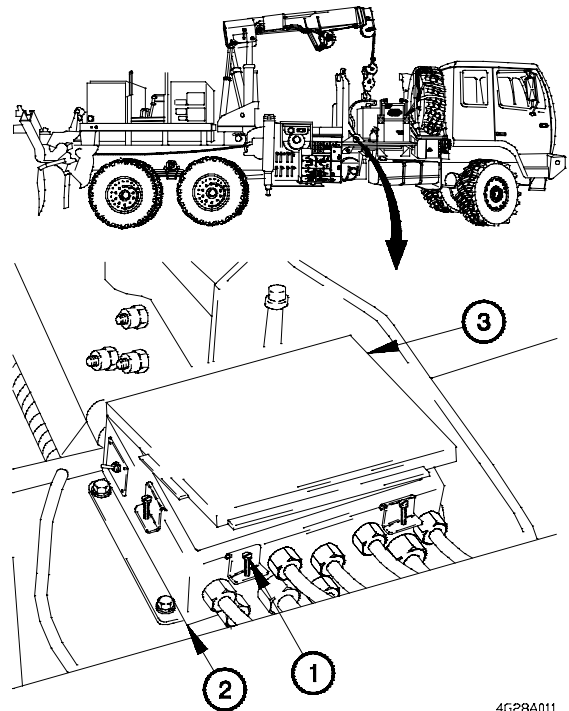

4G28A011

7-28. M1089 JUNCTION BOX ASSEMBLY REPLACEMENT/REPAIR (CONT)

NOTE

Tag wires and connection points prior to disconnecting.

- (3) Remove quick disconnect terminal (4) from ground strip (5) position 20.
- (4) Remove screw (6) from terminal block (7) position 19.

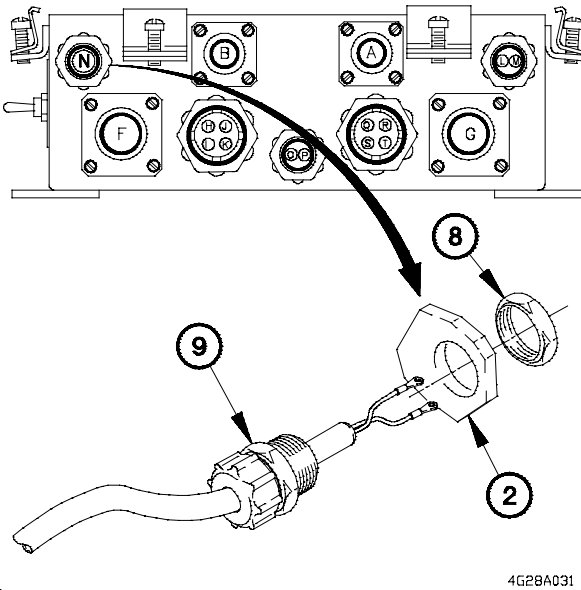

- (5) Remove conduit nut (8) and boom down lockout solenoid cable (9) from junction box (2). Discard conduit nut.

- (6) Remove quick disconnect terminal (10) from ground strip (5) position 3.
- (7) Remove three screws (11) from terminal block (7) positions 1, 17, and 19.

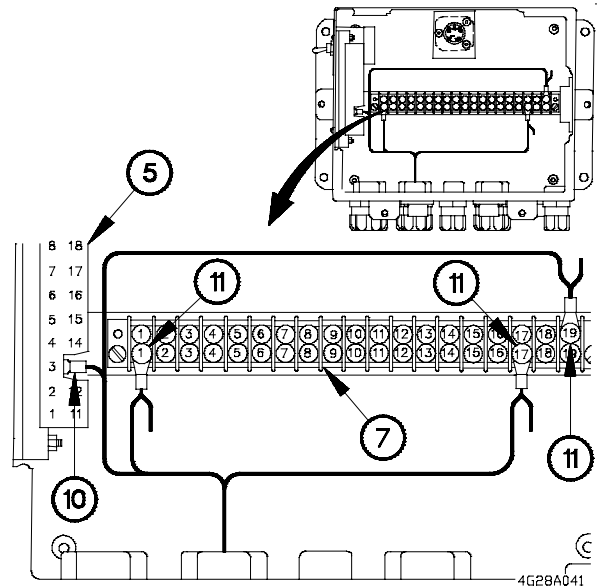
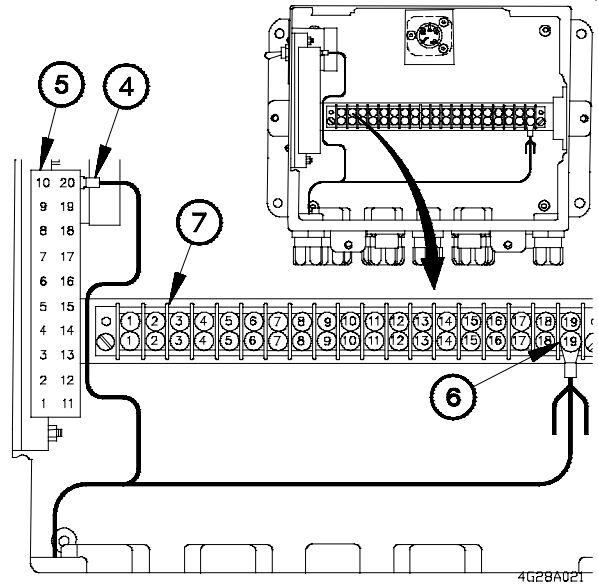

- (8) Remove four nuts (12), lockwashers (13), screws (14) and overload shutdown system cable (15) from junction box (2). Discard lockwashers.

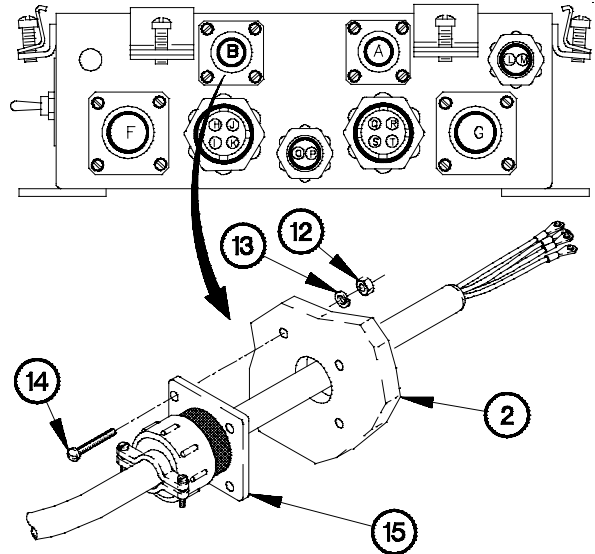

4G28A051

- (9) Remove quick disconnect terminal (16) from ground strip (5) position 2.
- (10) Remove three screws (17) from terminal block (7) positions 2, 3, and 4.

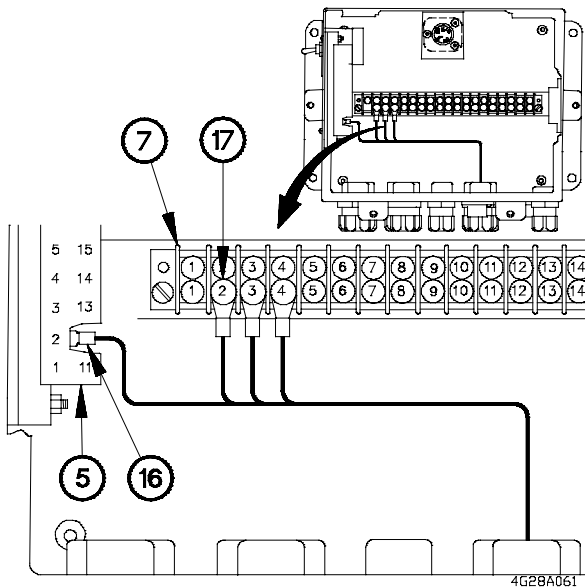

4G28A061

- (11) Remove four nuts (18), lockwashers (19), screws (20) and crane power cable (21) from junction box (2). Discard lockwashers.

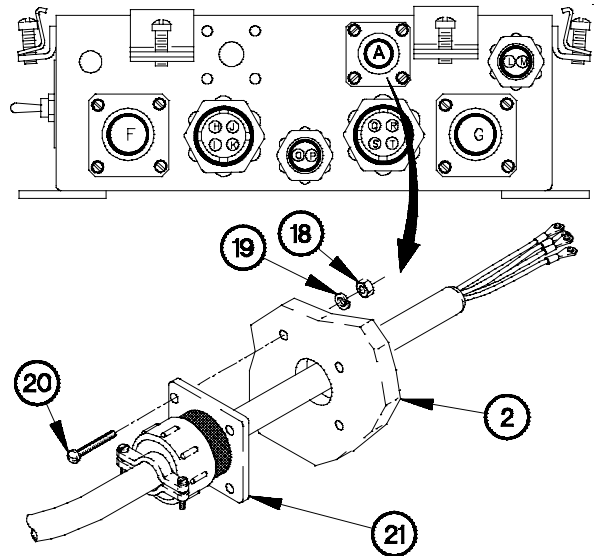

4G28A071

7-28. M1089 JUNCTION BOX ASSEMBLY REPLACEMENT/REPAIR (CONT)

(12) Remove two quick disconnect terminals (22) from ground strip (5) positions 14 and 15.

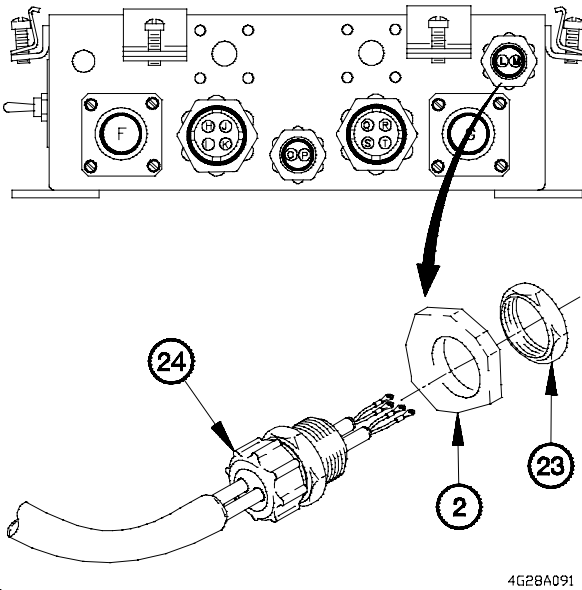

(13) Remove conduit nut (23), telescope out lockout solenoid and hoist up lockout solenoid cable assembly (24) from junction box (2). Discard conduit nut.

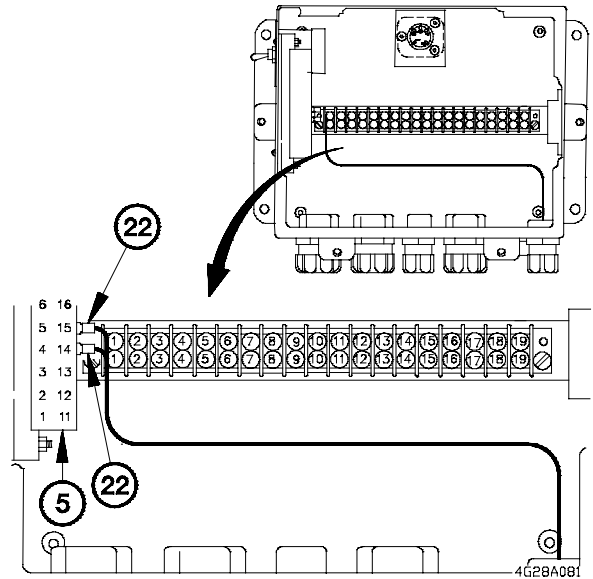

(14) Remove quick disconnect terminal (25) from ground strip (5) position 4.

(15) Remove 12 screws (26) from terminal block (7) positions 7 through 18.

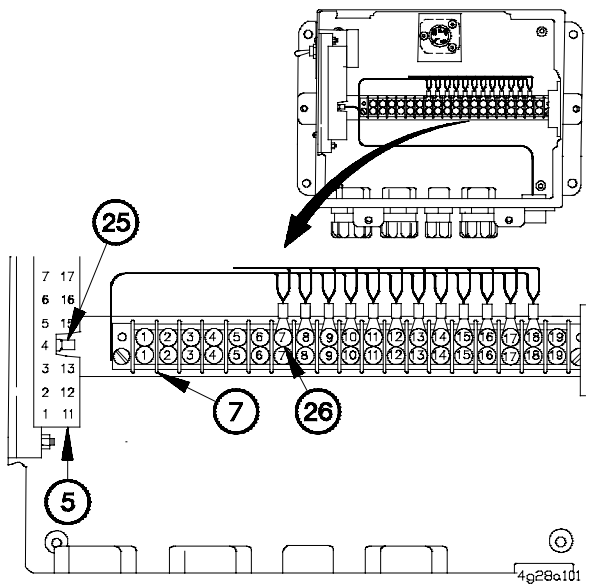

- (16) Remove four nuts (27), lockwashers (28), screws (29) and left side remote control cable (30) from junction box (2). Discard lockwashers.

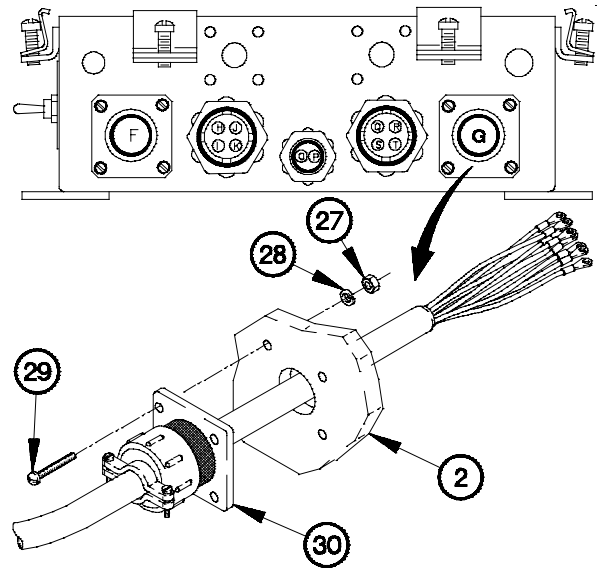

4G28A111

- (17) Remove four quick disconnect terminals (31) from ground strip (5) positions 16, 17, 18, and 19.
- (18) Remove four screws (32) from terminal block (7) positions 13 through 16.

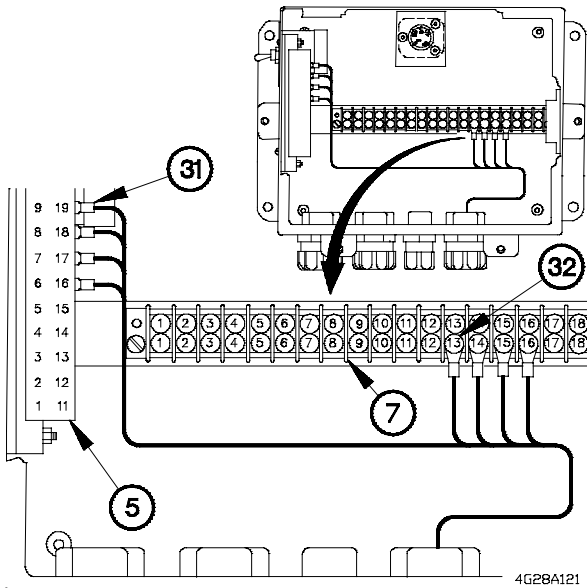

4G28A121

- (19) Remove conduit nut (33) and hoist up solenoid, hoist down solenoid, boom up solenoid, and boom down solenoid cable assembly (34) from junction box (2). Discard conduit nut.

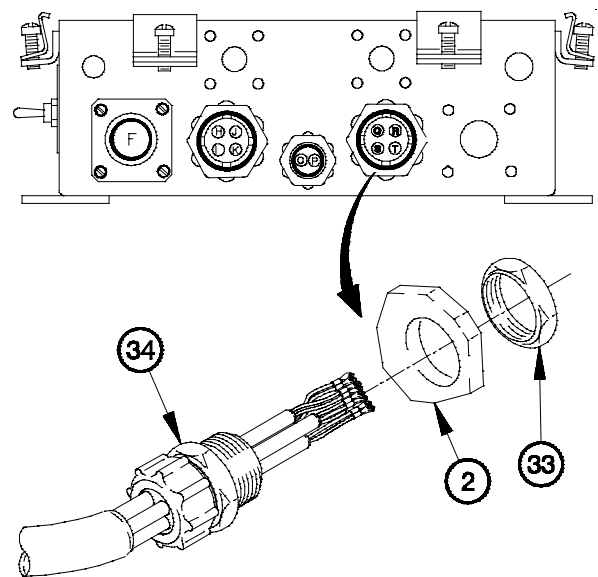

4G28A131

7-28. M1089 JUNCTION BOX ASSEMBLY REPLACEMENT/REPAIR (CONT)

- (20) Remove two quick disconnect terminals (35) from ground strip (5) positions 9 and 10.
- (21) Remove screw (36) from terminal block (7) position 5.

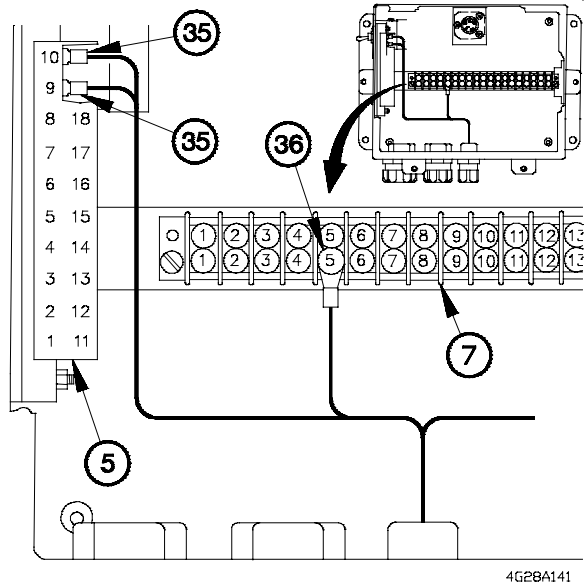

4G28A141

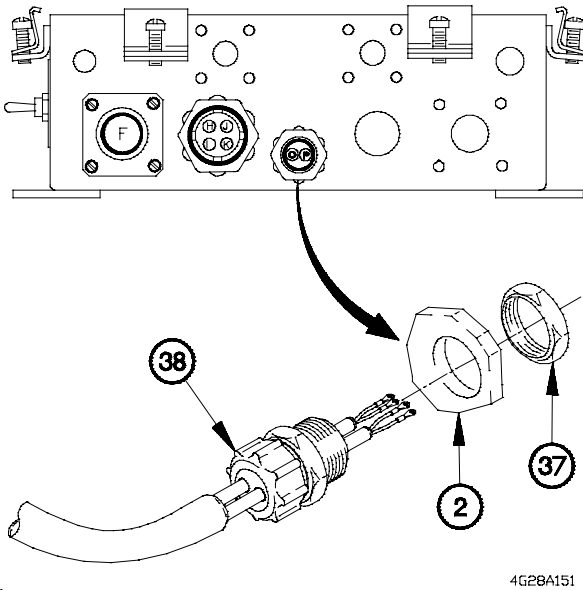

4G28A151

- (22) Remove conduit nut (37) and hydraulic system solenoid and boom up lockout solenoid cable assembly (38) from junction box (2). Discard conduit nut.

- (23) Remove four quick disconnect terminals (39) from ground strip (5) positions 5, 6, 7, and 8.
- (24) Remove four screws (40) from terminal block (7) positions 9 through 12.

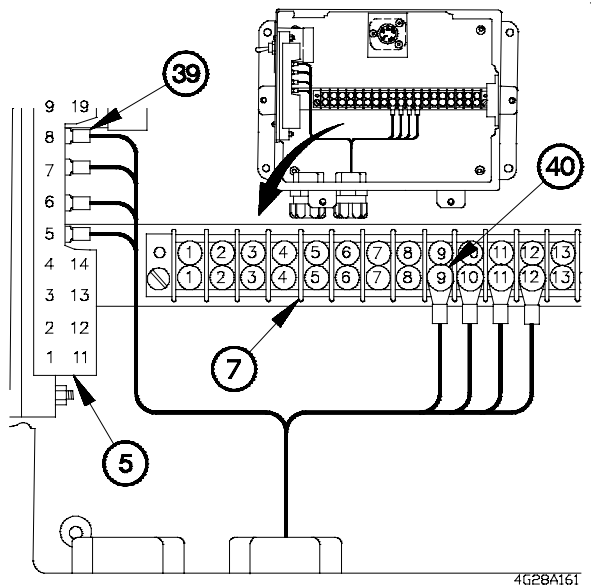

4G28A161

- (25) Remove conduit nut (41) and telescope in solenoid, telescope out solenoid, swing CCW solenoid, and swing CW solenoid cable assembly (42) from junction box (2). Discard conduit nut.

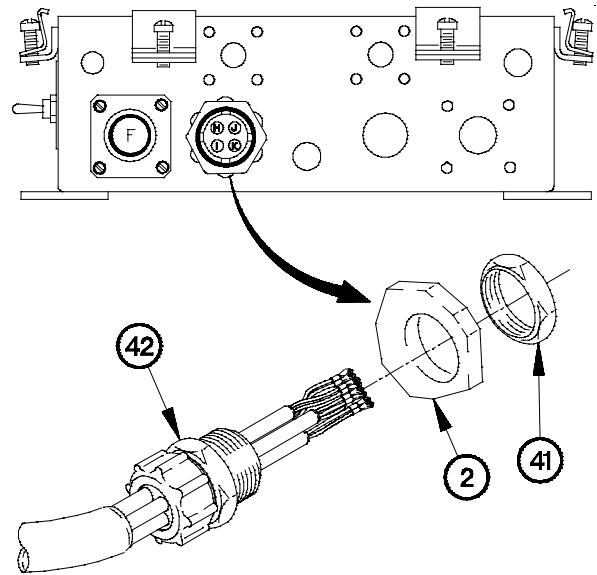

4G28A171

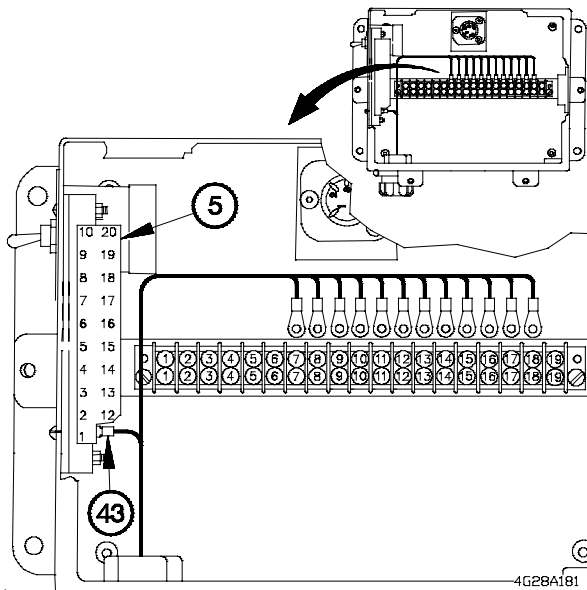

4G28A181

- (26) Remove quick disconnect terminal (43) from ground strip (5) position 1.

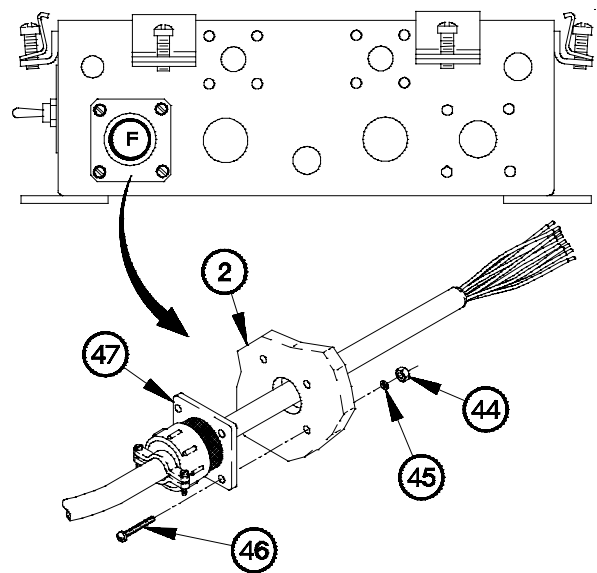

4G28A191

- (27) Remove four nuts (44), lockwashers (45), screws (46) and right side remote control cable (47) from junction box (2). Discard lockwashers.

7-28. M1089 JUNCTION BOX ASSEMBLY REPLACEMENT/REPAIR (CONT)

- (28) Remove four screws (48), lockwashers (49), and washers (50) from junction box (2). Discard lockwashers.
- (29) Remove junction box assembly (2) from crane.

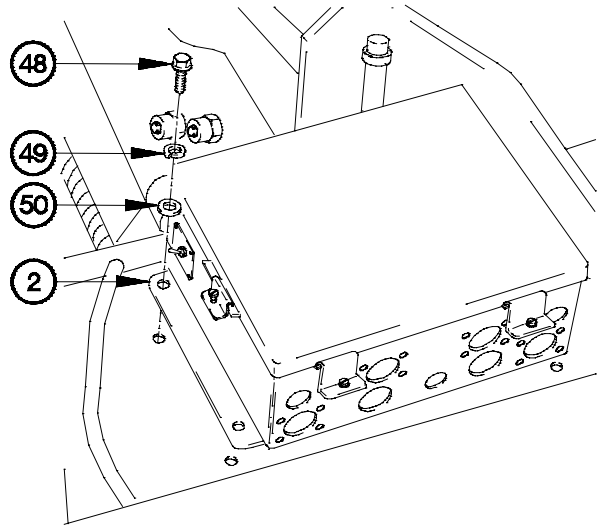

4G28A201

b. Disassembly.

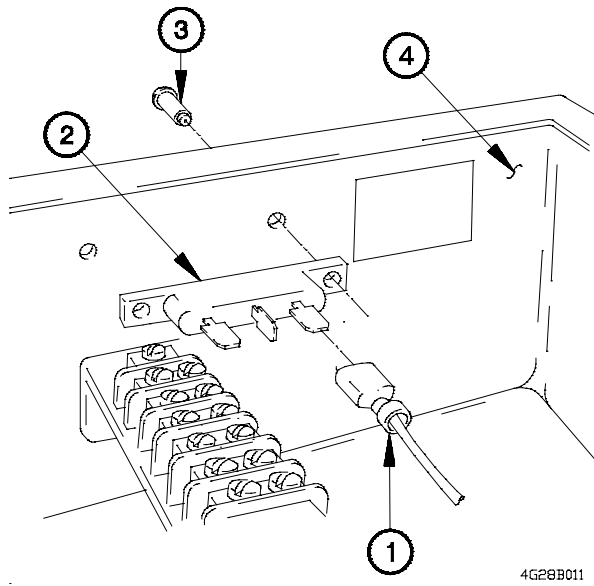

4G28B011

NOTE

Tag wires and connection points prior to disconnecting.

- (1) Remove three quick disconnect terminals (1) from diode assembly (2).

WARNING

Wear appropriate eye protection when removing rivets. Failure to comply may result in injury to personnel.

- (2) Remove two rivets (3) from diode assembly (2).
- (3) Remove diode assembly (2) from junction box (4).

NOTE

Perform steps (4) through (6) on junction boxes that have not had modification kit installed.

- (4) Unsolder five wires (5) from shutdown relay (6).

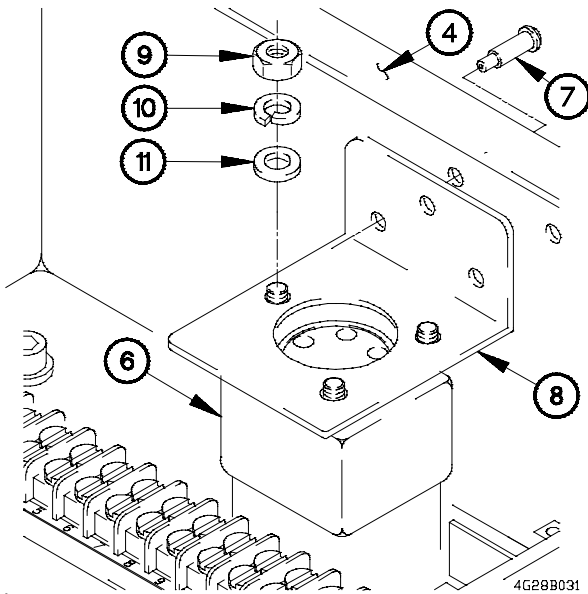

NOTE

Perform steps (6.1) through (6.3) on junction boxes that have modification kits installed.

- (6.1) Disconnect shutdown relay connector (11.1) from shutdown relay (11.2).
- (6.2) Remove nut (11.3), lockwasher (11.4), washer (11.5), shutdown relay (11.2) and screw (11.6) from bracket (11.7). Discard lockwasher.

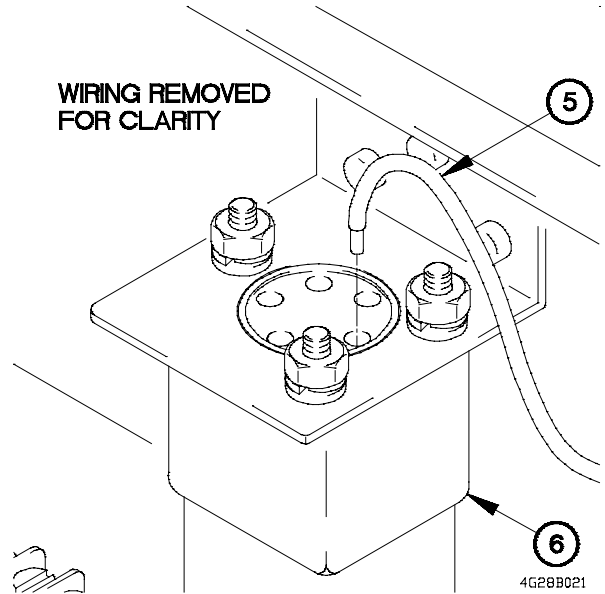

WARNING

Wear appropriate eye protection when removing rivets. Failure to comply may result in injury to personnel.

- (5) Remove three rivets (7) and bracket (8) from junction box (4).
- (6) Remove three nuts (9), lockwashers (10), washers (11), and shutdown relay (6) from bracket (8). Discard lockwashers.

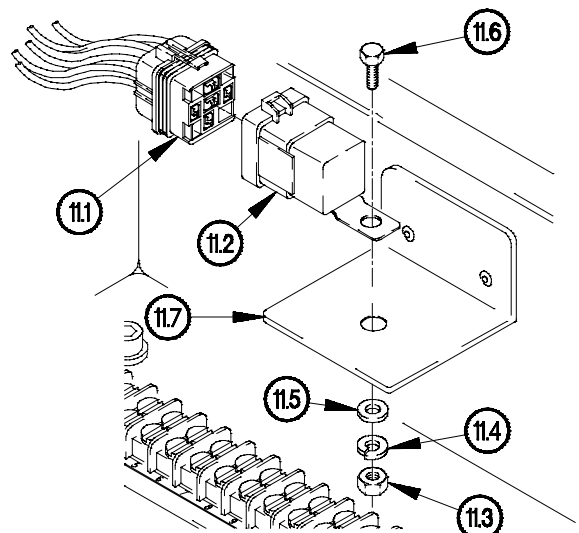

WARNING

Wear appropriate eye protection when removing rivets. Failure to comply may result in injury to personnel.

(6.3) Remove two rivets (11.8) and bracket (11.7) from junction box (4).

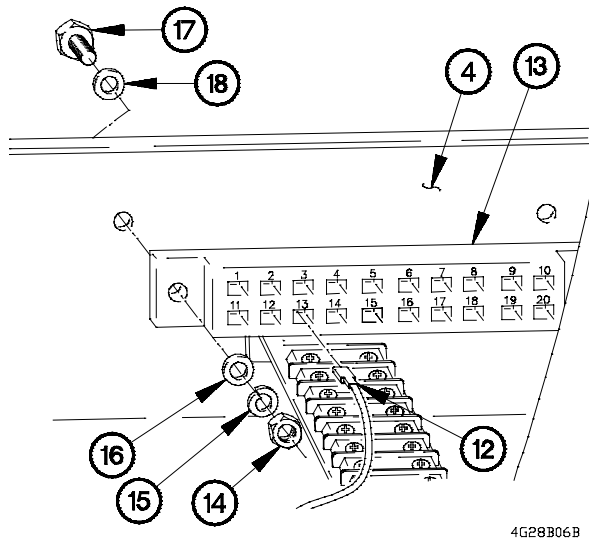
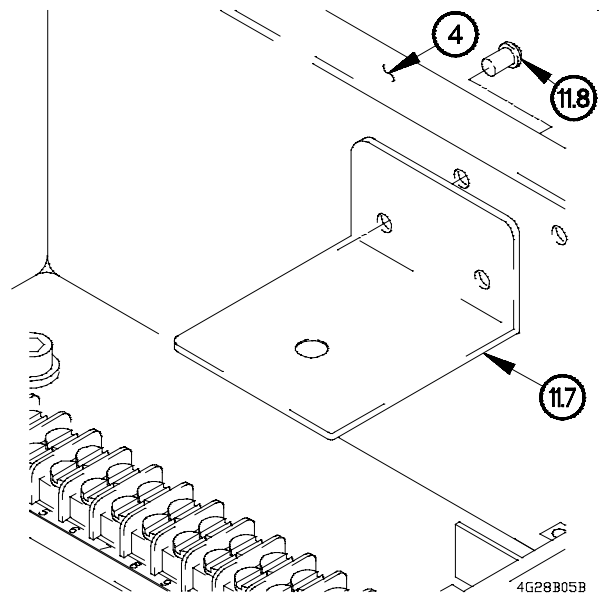

- (7) Remove quick disconnect terminal (12) from ground strip (13) position 13.
- (8) Remove two nuts (14), lockwashers (15), washers (16), screws (17), nylon washers (18), and ground strip (13) from junction box (4). Discard lockwashers.

7-28. M1089 JUNCTION BOX ASSEMBLY REPLACEMENT/REPAIR (CONT)

(9) Remove four screws (19) from terminal block (20) positions 1, 2, 5 and 6.

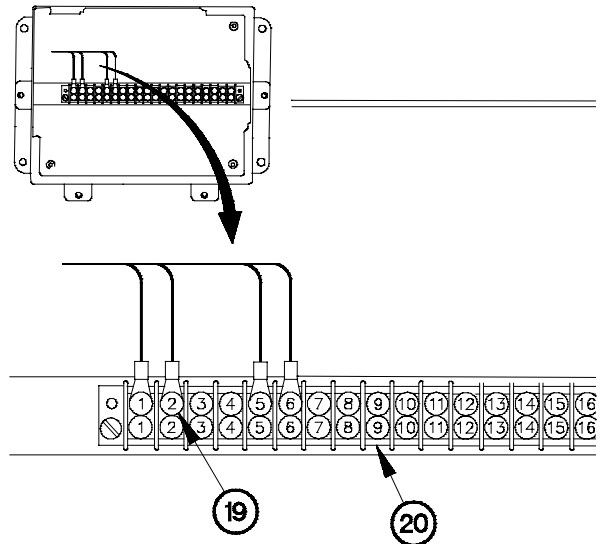

4G28B051

- (10) Remove nut (21), lockwasher (22), and locking (23) from circuit breaker (24). Discard lockwasher.
- (11) Remove circuit breaker (24) from junction box (4).
- (12) Remove two screws (25), lockwashers (26), and terminal lugs (27) from circuit breaker (24). Discard lockwashers.

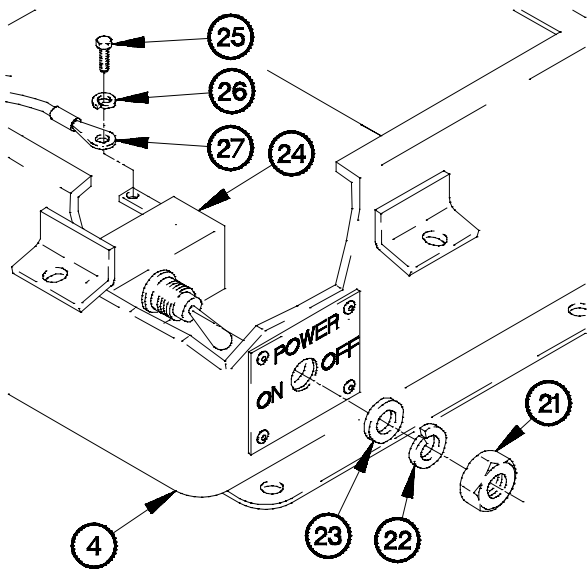

4G28B061

WARNING

Wear appropriate eye protection when removing rivets. Failure to comply may result in injury to personnel.

(13) Remove four rivets (28) and panel (29) from junction box (4).

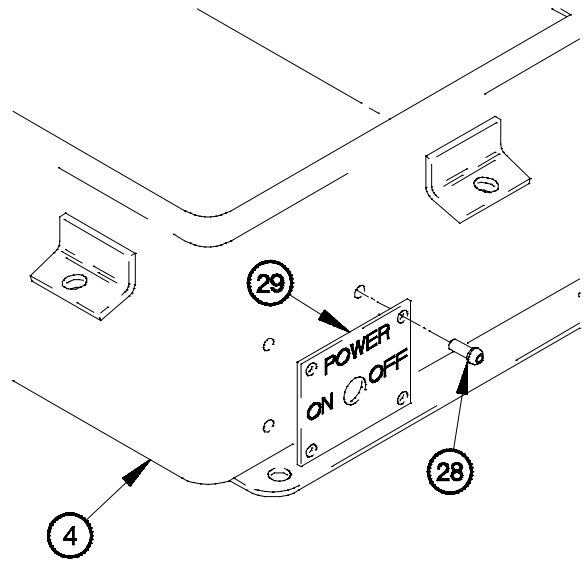

4G28B071

- (14) Remove two screws (30) from terminal block (20) positions 7 and 8.

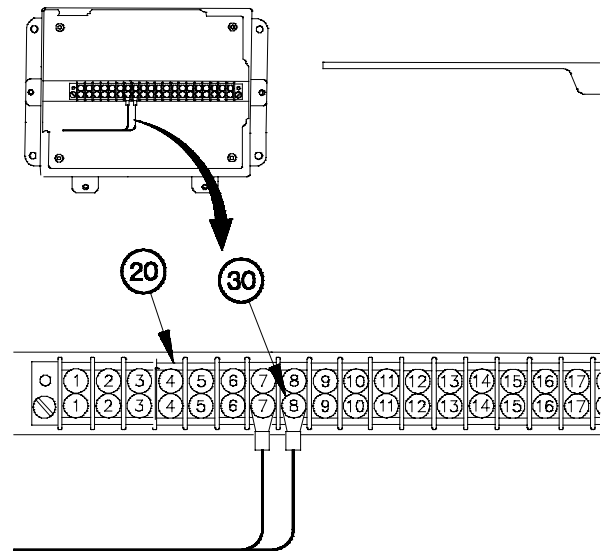

4G28B081

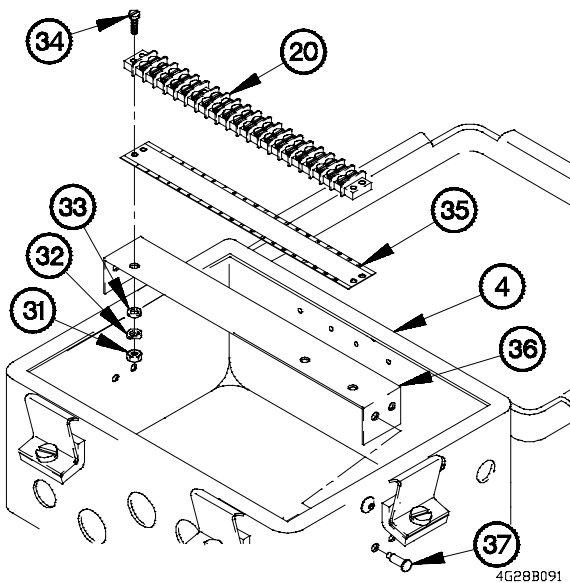

4G28B091

- (15) Remove two nuts (31), lockwashers (32), washers (33), screws (34), decal (35), and terminal block (20) from bracket (36). Discard lockwashers.

WARNING

Wear appropriate eye protection when removing rivets. Failure to comply may result in injury to personnel.

- (16) Remove four rivets (37) and bracket (36) from junction box (4).

7-28. M1089 JUNCTION BOX ASSEMBLY REPLACEMENT/REPAIR (CONT)

c. Assembly.

- (1) Install bracket (1) on junction box (2) with four rivets (3).
- (2) Install decal (4) and terminal block (5) on bracket (1) with two screws (6), washers (7), lockwashers (8), and nuts (9).

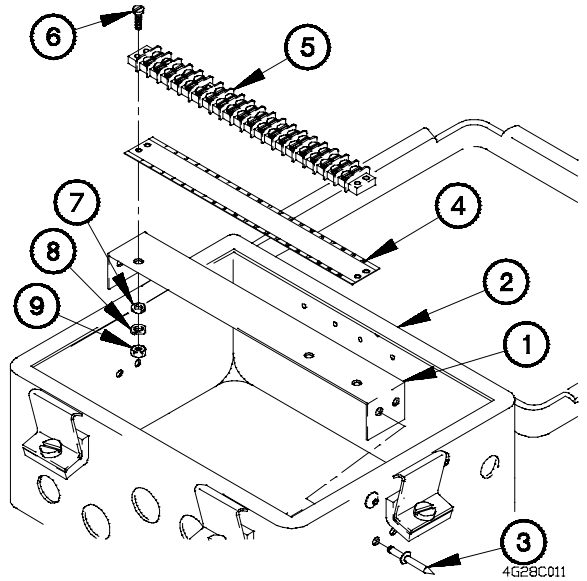

4G28C011

- (3) Install two terminal lugs (10) on terminal block (5) positions 7 and 8 with two screws (11).

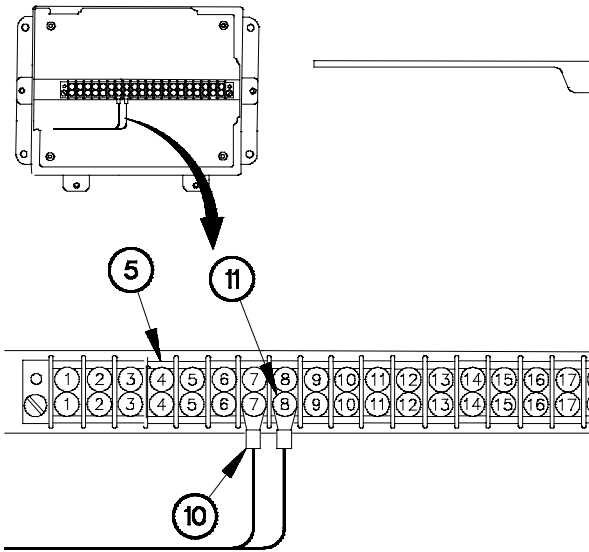

4G28C021

- (4) Install panel (12) on junction box (2) with four rivets (13).

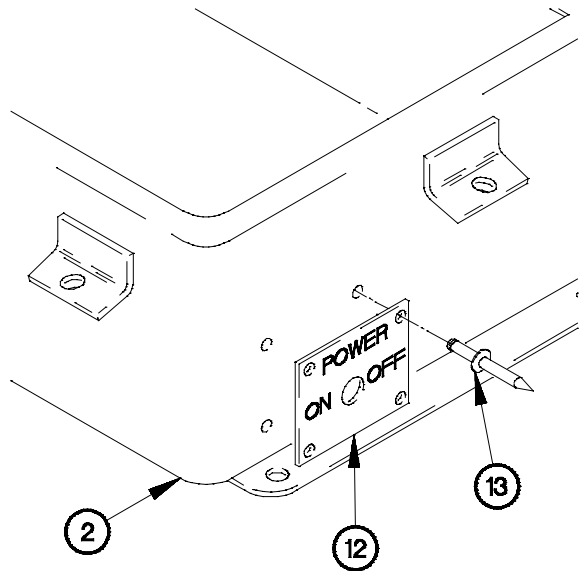

4G28C031

- (5) Install two terminal lugs (14) on circuit breaker (15) with two lockwashers (16) and screws (17).
- (6) Position circuit breaker (15) in junction box (2) with locking (18), lockwasher (19), and nut (20).
- (7) Tighten nut (20) to 25 lb-in. (3 N-m).

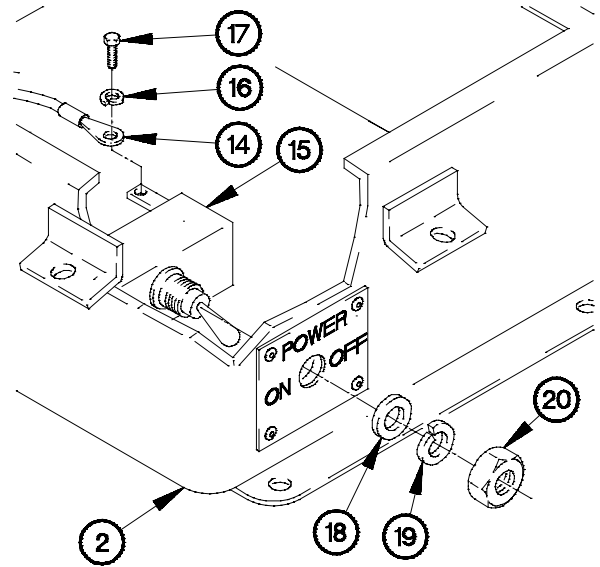

4G28C041

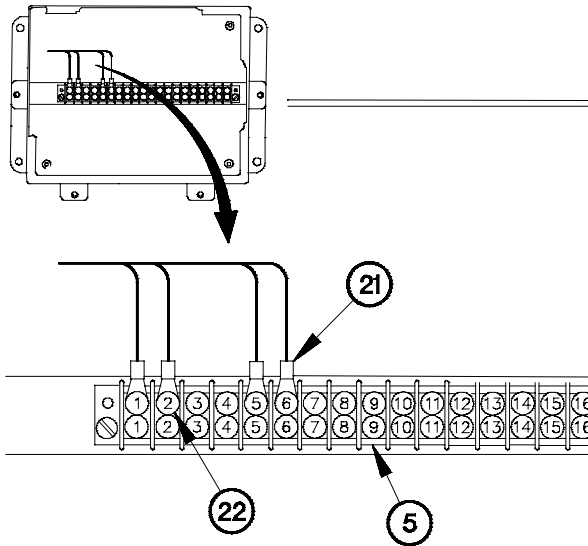

4G28C051

- (8) Install four terminal lugs (21) on terminal block (5) positions 1, 2, 5 and 6 with four screws (22).

- (9) Install ground strip (23) on junction box (2) with two nylon washers (24), screws (25), washers (26), lockwashers (27), and nuts (28).
- (10) Install quick disconnect terminal (29) in ground strip (23) position 13.

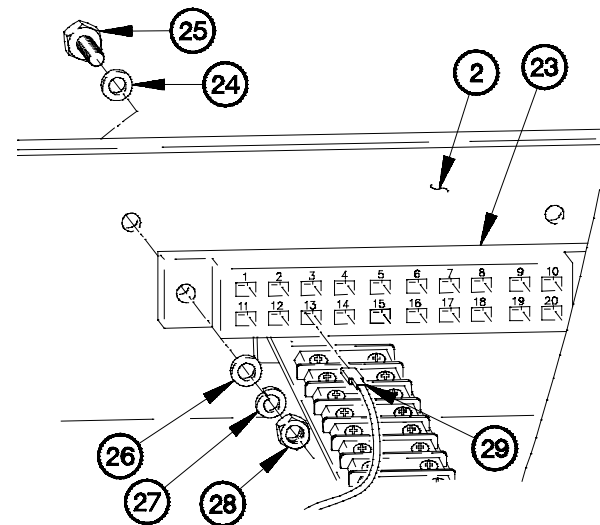

4G28C061

7-28. M1089 JUNCTION BOX ASSEMBLY REPLACEMENT/REPAIR (CONT)

NOTE

Perform steps (10.1) through (10.3) on junction boxes that have had modification kit installed.

- (10.1) Install shutdown relay (29.1) on bracket (29.2) with screw (29.3), washer (29.4), lockwasher (29.5) and nut (29.6).
- (10.2) Connect shutdown relay connector (29.7) to shutdown relay (29.1).

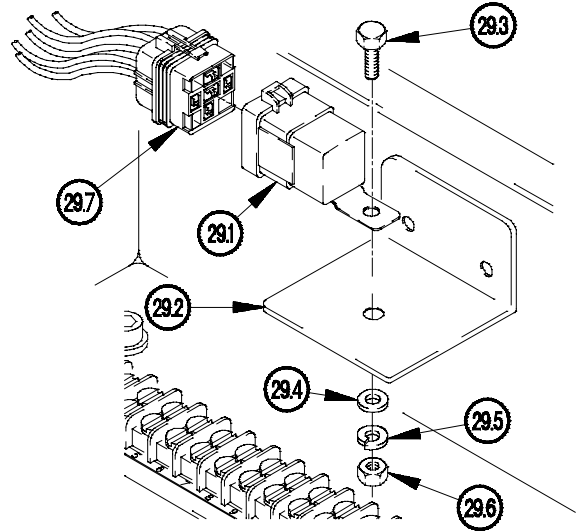

4G29C07B

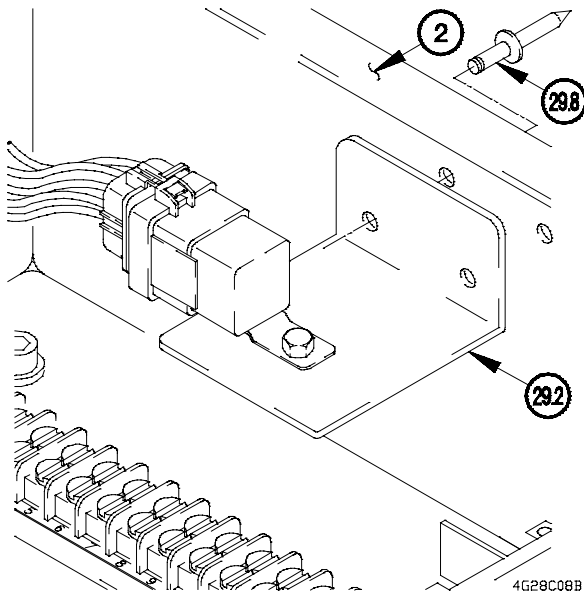

4G29C08B

- (10.3) Install bracket (29.2) on junction box (2) with two rivets (29.8).

NOTE

Perform steps (11) through (14) on junction boxes that have not had modification kit installed.

- (11) Install shutdown relay (30) on bracket (31) with three washers (32), lockwashers (33), and nuts (34).
- (12) Install bracket (31) on junction box (2) with three rivets (35).

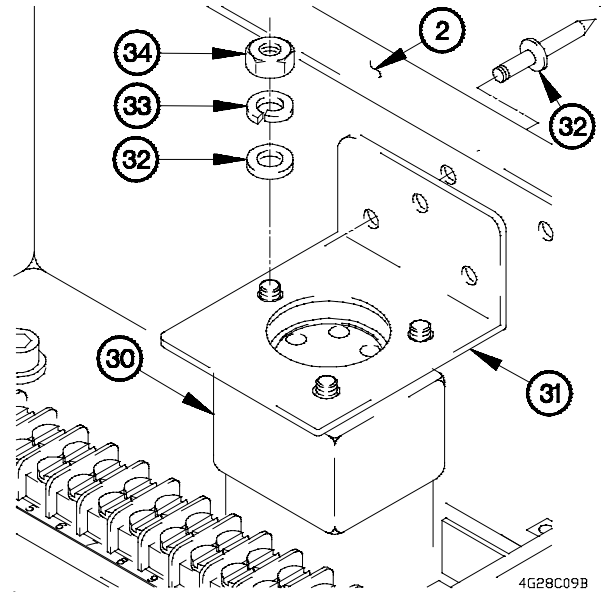

WIRING REMOVED FOR CLARITY

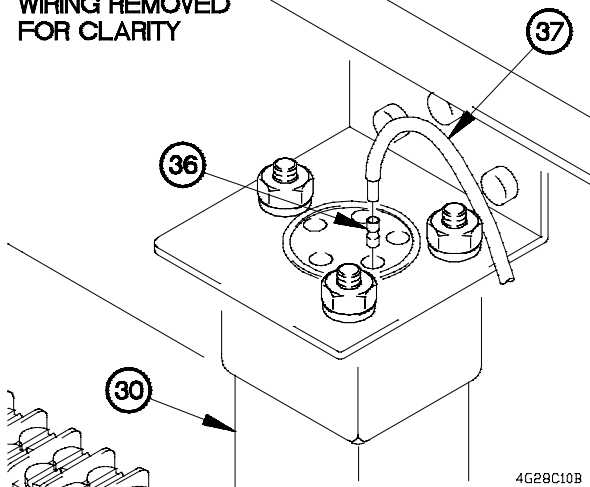

- (13) Install shrink tubing (36) over ends of five wires (37) and solder ends on shutdown relay (30) positions 1 through 5.
- (14) Shrink the tubing over ends of all relay pins.

- (15) Install diode assembly (38) on junction box (2) with two rivets (39).
- (16) Connect three quick disconnect terminals (40) on diode assembly (38).
- (17) Apply varnish to quick disconnect terminals (40).

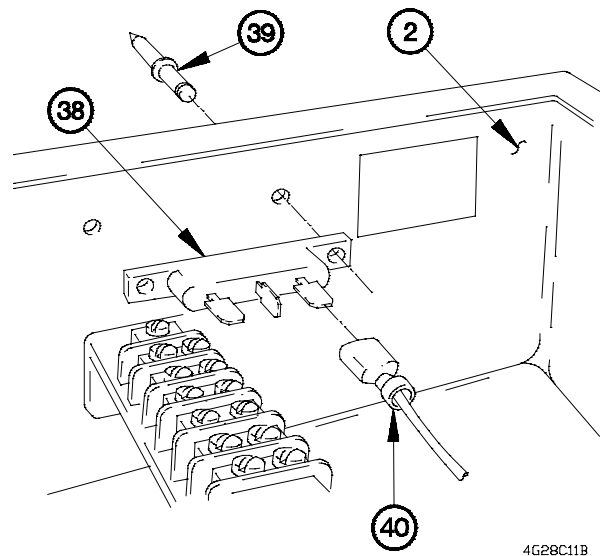

d. Installation.

- (1) Install junction box (1) on crane with four washers (2), lockwashers (3), and screws (4).
- (2) Loosen four screws (5) on junction box (1).
- (3) Open cover (6) on junction box (1).

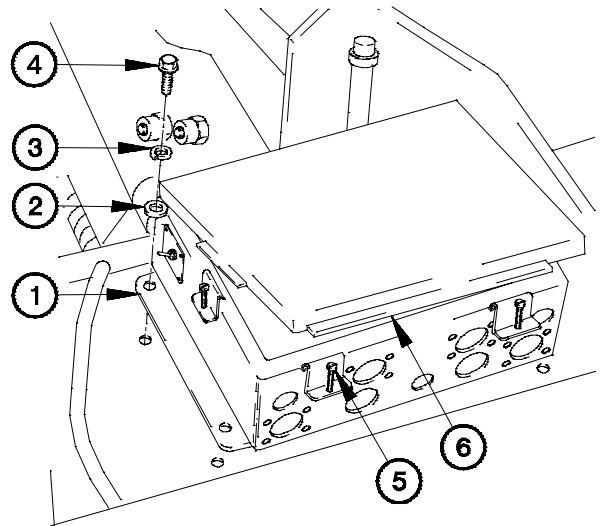

4G28D011

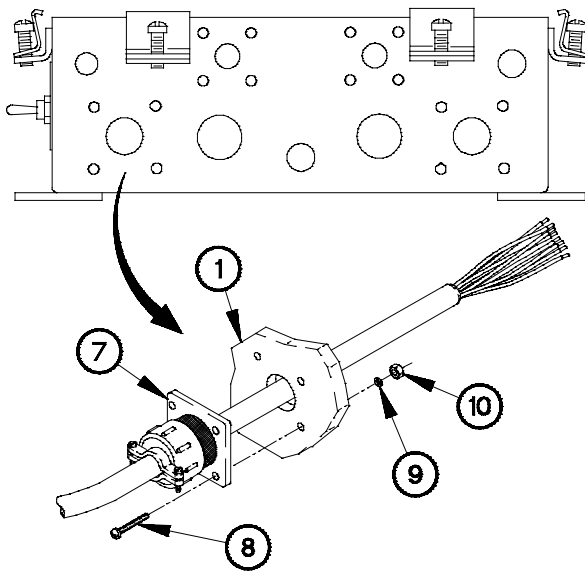

4G28D021

- (4) Install right side remote control cable (7) in junction box (1) with four screws (8), lockwashers (9), and nuts (10).

- (5) Install quick disconnect terminal (11) on ground strip (12) position 1.

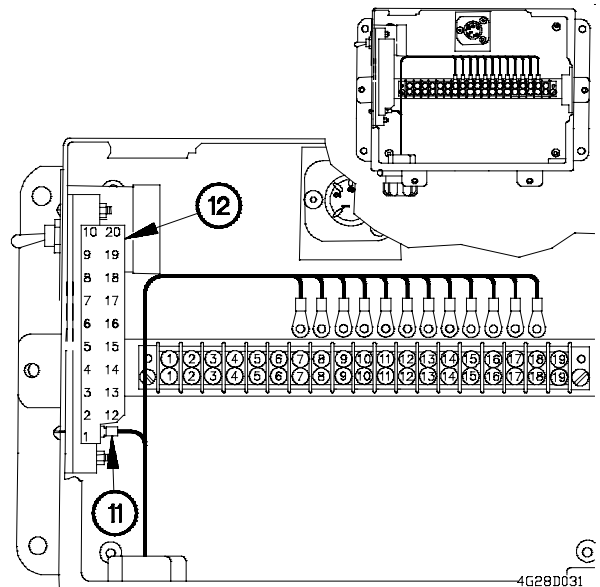

4G28D031

7-28. M1089 JUNCTION BOX ASSEMBLY REPLACEMENT/REPAIR (CONT)

(6) Install telescope in solenoid, telescope out solenoid, swing CCW solenoid, and swing CW solenoid cable assembly (13) in junction box (1) with conduit nut (14).

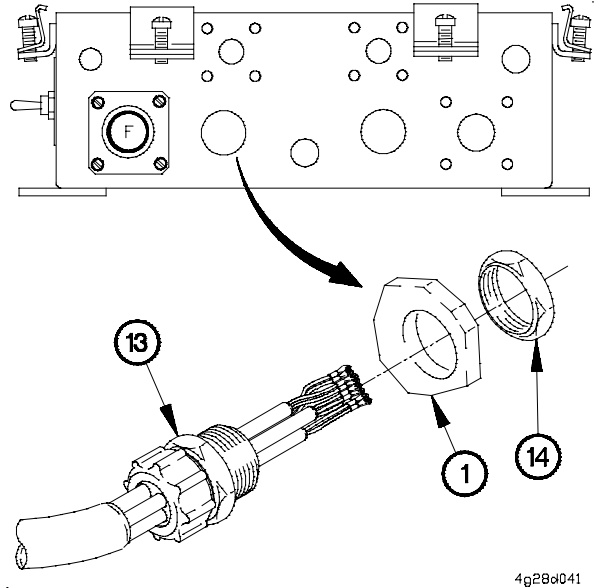

(7) Install four quick disconnect terminals (15) on ground strip (12) positions 5, 6, 7, and 8.

(8) Install four terminal lugs (16) on terminal block (17) positions 9 through 12 with four screws (18).

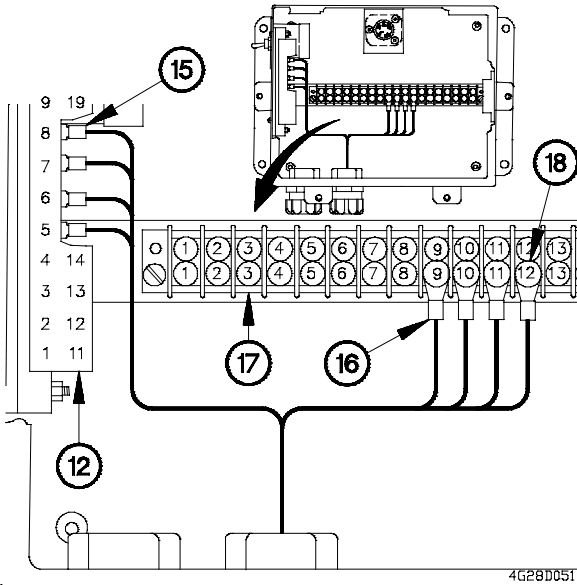

(9) Install hydraulic system solenoid and boom up lockout solenoid cable assembly (19) in junction box (1) with conduit nut (20).

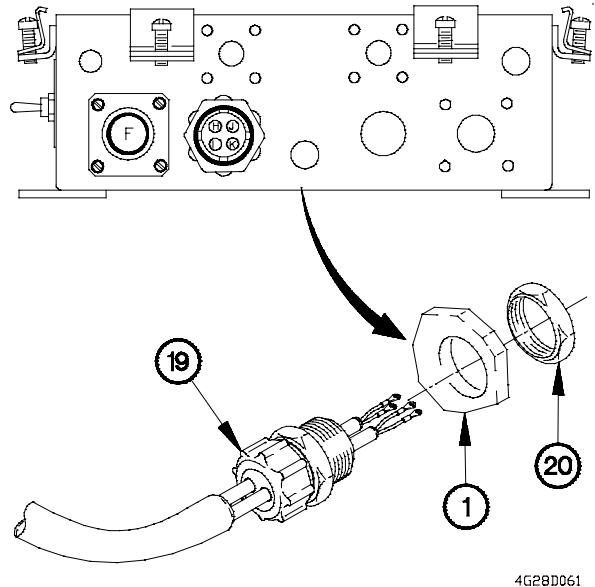

- (10) Install quick disconnect terminals (21) on ground strip (12) positions 9 and 10.
- (11) Install terminal lug (22) on terminal block (17) position 5 with screw (23).

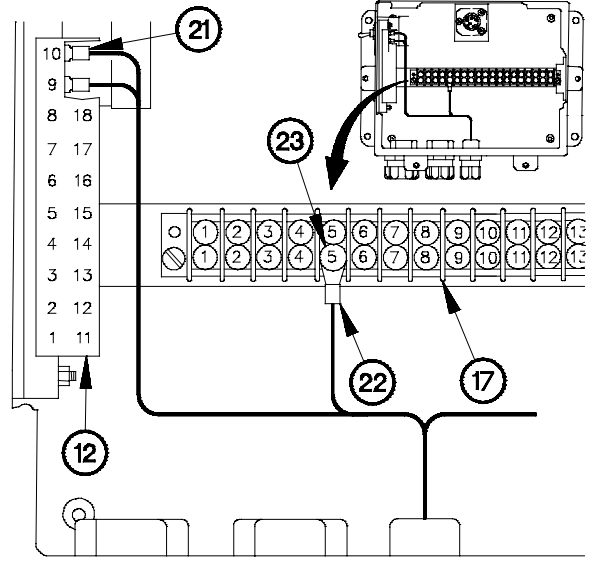

4G28D071

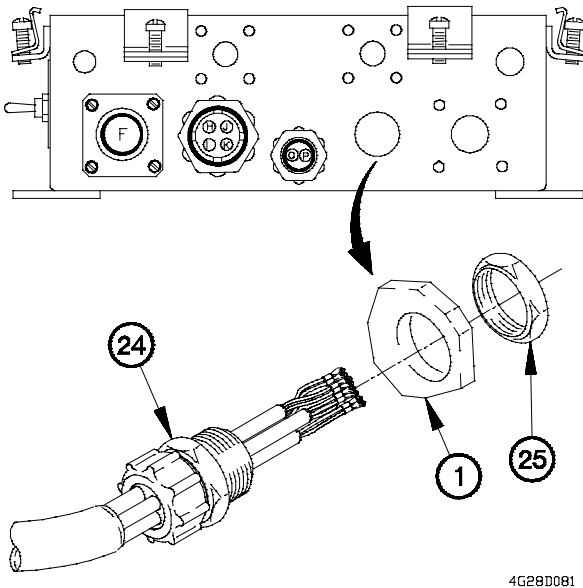

4G28D081

- (12) Install hoist up solenoid, hoist down solenoid, boom up solenoid, and boom down solenoid cable assembly (24) in junction box (1) with conduit nut (25).

- (13) Install four quick disconnect terminals (26) on ground strip (12) positions 16, 17, 18, and 19.
- (14) Install four terminal lugs (27) on terminal block (17) positions 13 through 16 with four screws (28).

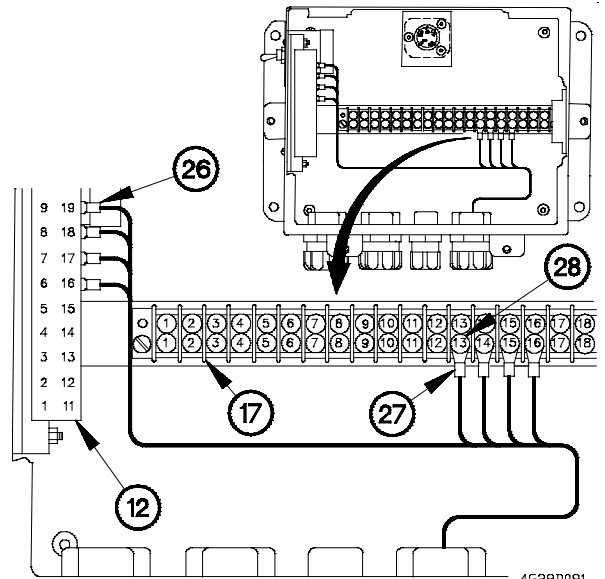

4G28D091

7-28. M1089 JUNCTION BOX ASSEMBLY REPLACEMENT/REPAIR (CONT)

(15) Install left side remote control cable (29) in junction box (1) with four screws (30), lockwashers (31), and nuts (32).

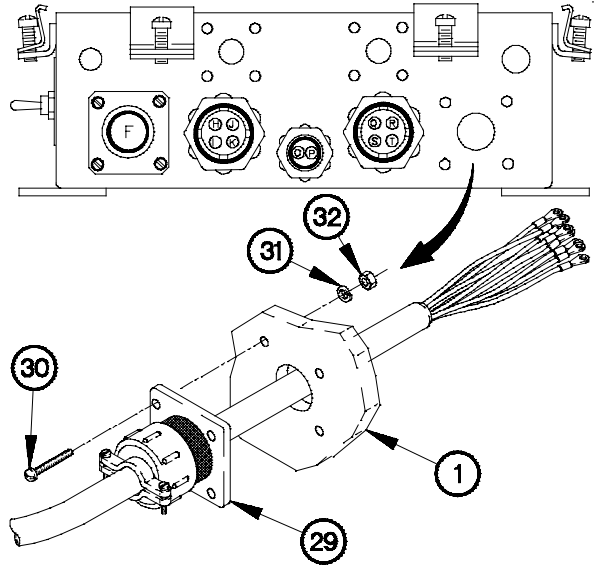

4G28D101

(16) Install quick disconnect terminal (33) on ground strip (12) position 4.

(17) Install terminal lugs (34) on terminal block (17) positions 7 through 18 with 12 screws (35).

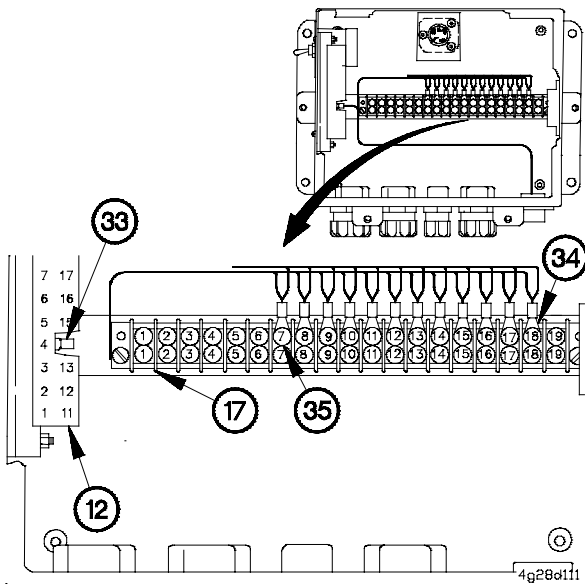

4g28d11

(18) Install telescope out lockout solenoid, and hoist up lockout solenoid cable assembly (36) in junction box (1) with conduit nut (37).

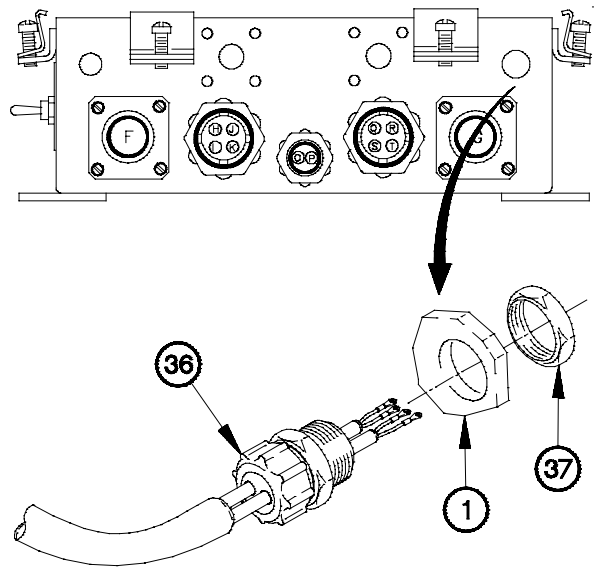

4G28D121

(19) Install quick disconnect terminals (38) on ground strip (12) positions 14 and 15.

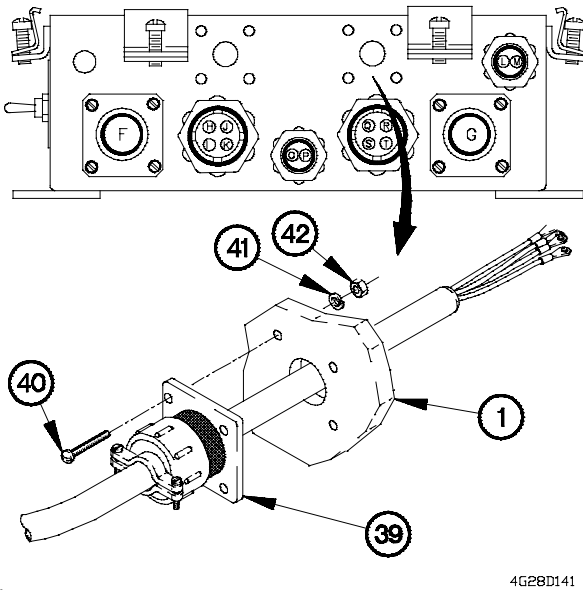

(20) Install crane power cable (39) in junction box (1) with four screws (40), lockwashers (41), and nuts (42).

(21) Install quick disconnect terminal (43) on ground strip (12) position 2.

(22) Install three terminal lugs (44) on terminal block (17) positions 2 through 4 with three screws (45).

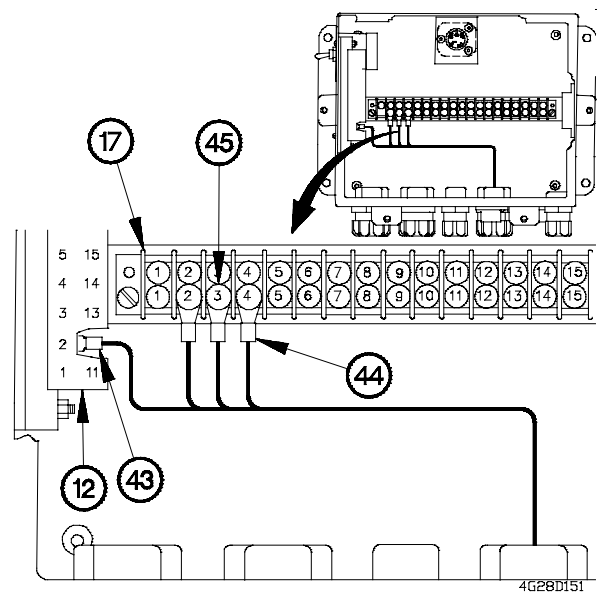
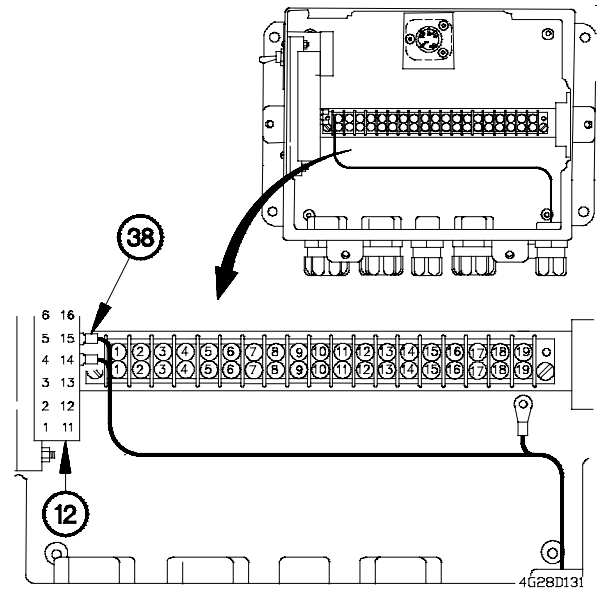

7-28. M1089 JUNCTION BOX ASSEMBLY REPLACEMENT/REPAIR (CONT)

(23) Install overload shutdown system cable (46) in junction box (1) with four screws (47), lockwashers (48), and nuts (49).

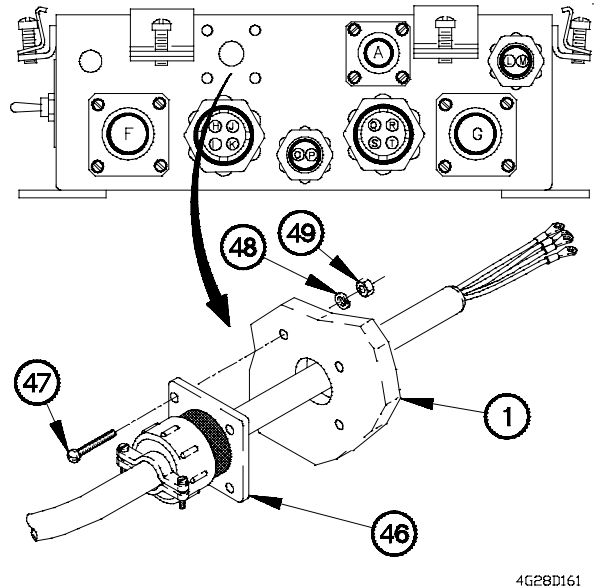

4G28D161

(24) Install quick disconnect terminal (50) on ground strip (12) position 3.

(25) Install four terminal lugs (51) on terminal block (17) positions 1, 17 and 19 with three screws (52).

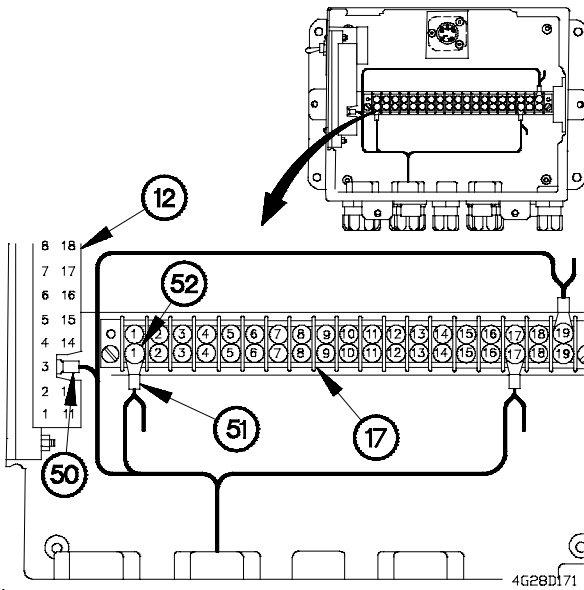

4G28D171

(26) Install boom down lockout solenoid cable (53) in junction box (1) with conduit nut (54).

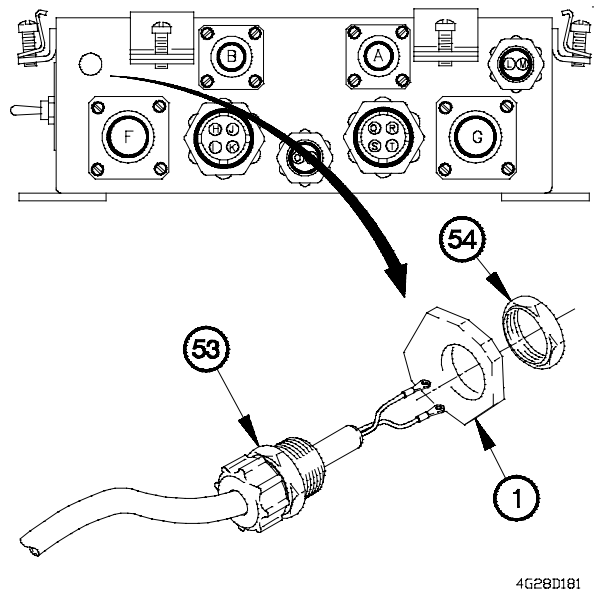

4G28D181

- (27) Install quick disconnect terminal (55) on ground strip (12) position 20.
- (28) Install terminal lug (56) on terminal block (17) position 19 with screw (57).

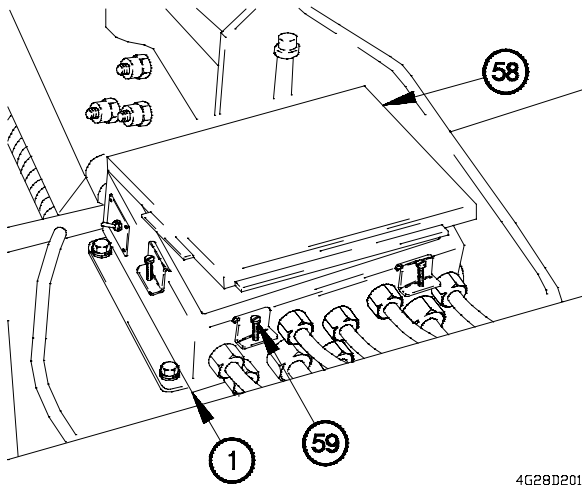
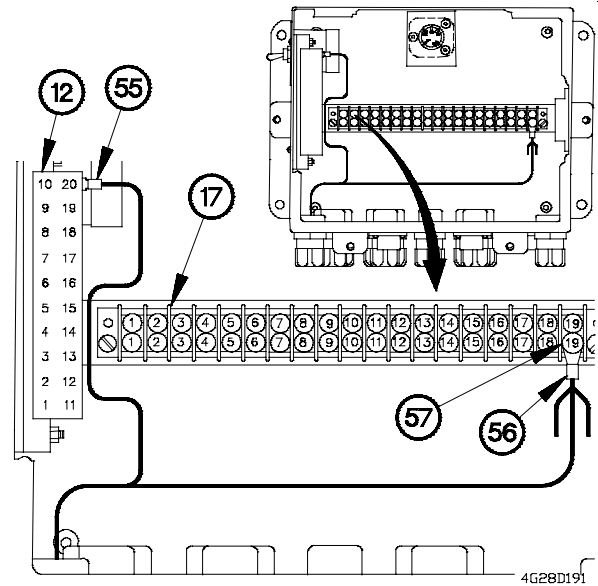

- (29) Close cover (58) on junction box (1).
- (30) Tighten four screws (59) on junction box (1).

e. Follow-On Maintenance.

- (1) Connect batteries (para 7-57).
- (2) Operate crane and check all crane functions (TM 9-2320-366-10-1).

End of Task.

7-29. SHUNT REPLACEMENT	
This task covers:	
a. Removal b. Installation	c. Follow-On Maintenance
INITIAL SETUP	
Equipment Conditions Spare tire lowered (TM 9-2320-366-10-2). Batteries disconnected (para 7-57).	Materials/Parts Dispenser, Pressure Sensitive Adhesive Tape (Item 20, Appendix D) Lockwasher (2) (Item 86, Appendix G) Lockwasher (2) (Item 87, Appendix G) Nut, Self-Locking (2) (Item 150, Appendix G)
Tools and Special Tools Tool Kit, Genl Mech (Item 46, Appendix C) Wrench, Torque, 0-75 lb-in. (Item 90, Appendix B)	

a. Removal.

- (1) Loosen clamp (1) on air hose (2).
- (2) Remove air hose (2) from intake air cleaner boot (3).

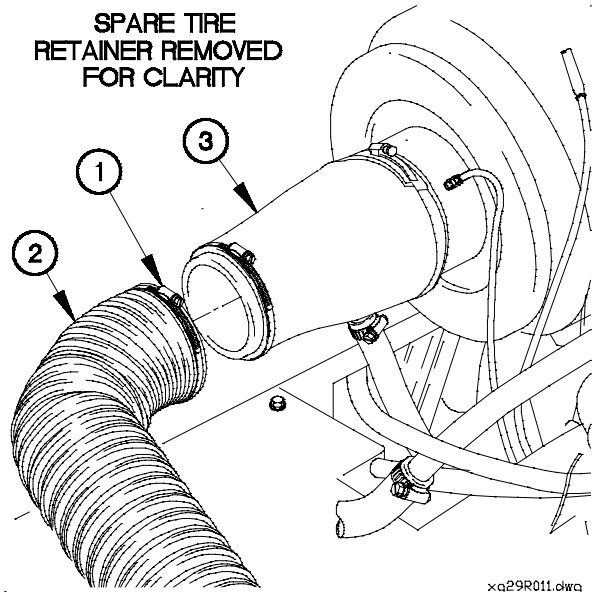

xq29R011.dwg

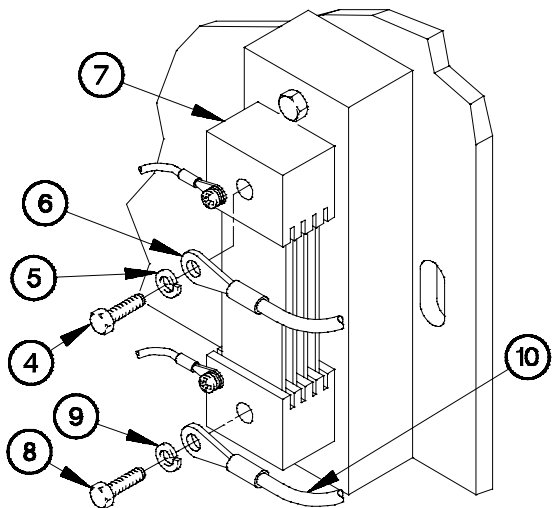

xq29R021.dwg

NOTE

Tag wires and connection points prior to disconnecting.

- (3) Remove screw (4), lockwasher (5), and terminal lug TL52 (6) from shunt (7). Discard lockwasher.
- (4) Remove screw (8), lockwasher (9), and terminal lug TL45 (10) from shunt (7). Discard lockwasher.

- (5) Remove screw (11), lockwasher (12), washer (13), and terminal lug TL51 (14) from shunt (7). Discard lockwasher.
- (6) Remove screw (15), lockwasher (16), washer (17), and terminal lug TL38 (18) from shunt (7). Discard lockwasher.

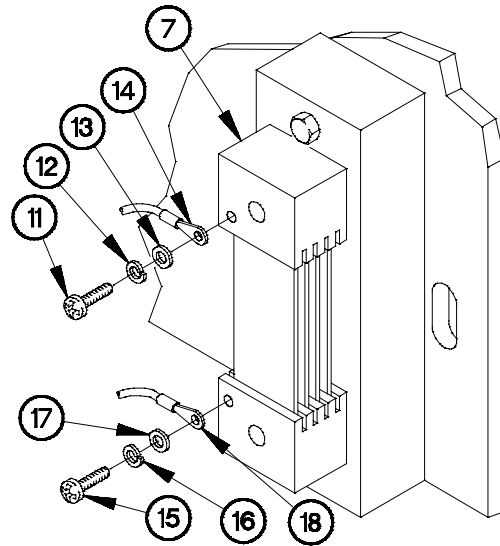

xq29R031.dwg

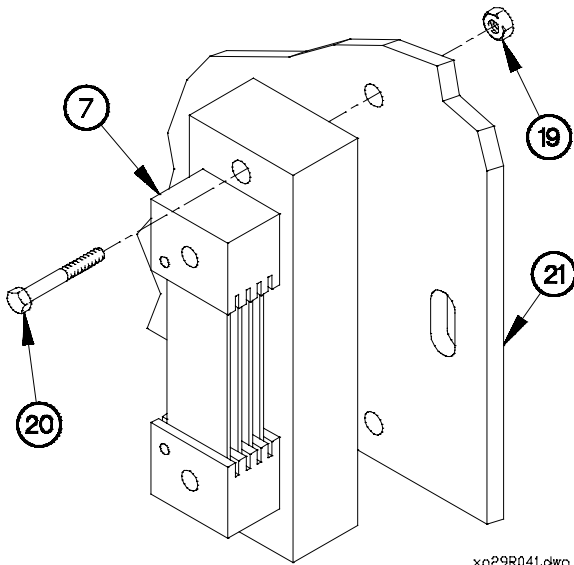

xq29R041.dwg

- (7) Remove two self-locking nuts (19), screws (20), and shunt (7) from spare tire retainer (21). Discard self-locking nuts.

b. Installation.

- (1) Install shunt (1) on spare tire retainer (2) with two screws (3) and self-locking nuts (4).

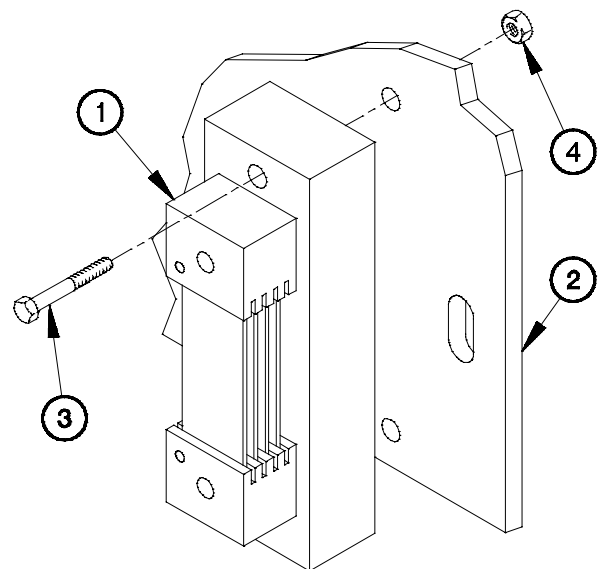

xq29I011.dwg

7-29. SHUNT REPLACEMENT (CONT)

- (2) Install terminal lug TL38 (5) on shunt (1) with washer (6), lockwasher (7), and screw (8).
- (3) Install terminal lug TL51 (9) on shunt (1) with washer (10), lockwasher (11), and screw (12).

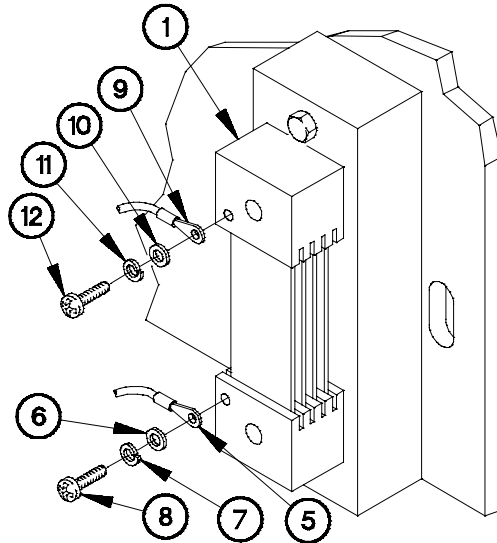

xa291021.dwg

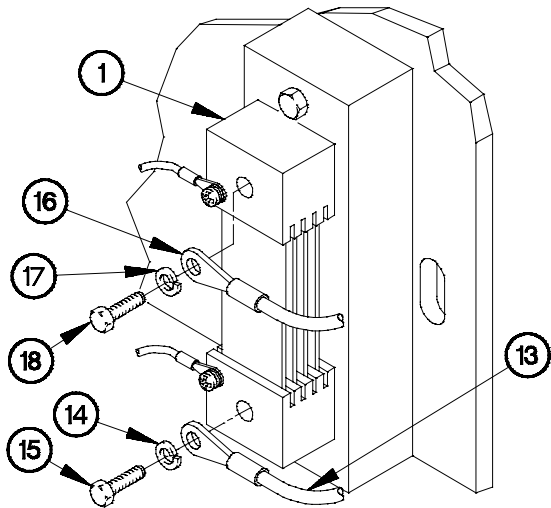

xa291031.dwg

- (4) Install terminal lug TL45 (13) on shunt (1) with lockwasher (14) and screw (15).
- (5) Install terminal lug TL52 (16) on shunt (1) with lockwasher (17) and screw (18).

- (6) Position air hose (19) on intake air cleanerboot (20) with clamp (21).
- (7) Tighten clamp (21) to 36-48 lb-in. (4-5 N·m).

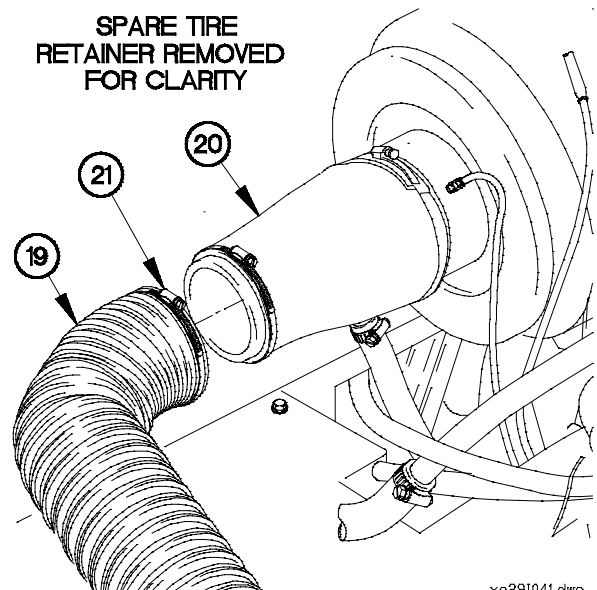

xa291041.dwg

c. Follow-On Maintenance.

- (1) Connect batteries (para 7-57).
- (2) Raise spare tire (TM 9-2320-366-10-2).
- (3) Start engine (TM 9-2320-366-10-1).
- (4) Check VOLTS gage for charge indication (TM 9-2320-366-10-1).
- (5) Shut down engine (TM 9-2320-366-10-1).

End of Task.

7-30. 100 AMP REVERSE POLARITY RELAY REPLACEMENT

This task covers:

- a. Removal
- b. Installation
- c. Follow-On Maintenance

INITIAL SETUP

Equipment Conditions

Spare tire lowered (TM 9-2320-366-10-2).
 Batteries disconnected (para 7-57).

Tools and Special Tools

Tool Kit, Genl Mech (Item 46, Appendix C)
 Wrench, Torque, 0-200 lb-in. (Item 59, Appendix C)
 Socket Set, Socket Wrench (Item 34, Appendix C)

Materials/Parts

Dispenser, Pressure Sensitive Adhesive Tape (Item 20, Appendix D)
 Lockwasher (4) (Item 95, Appendix G)
 Washer, Spring (6) (Item 290, Appendix G)
 Nut, Self-Locking (6) (Item 165, Appendix G)

a. Removal.

NOTE

Tag wires and connection points prior to disconnecting.

- (1) Loosen clamp (1) on intake air cleaner boot (2).
- (2) Remove intake air cleaner boot (2) from intake air cleaner housing (3).

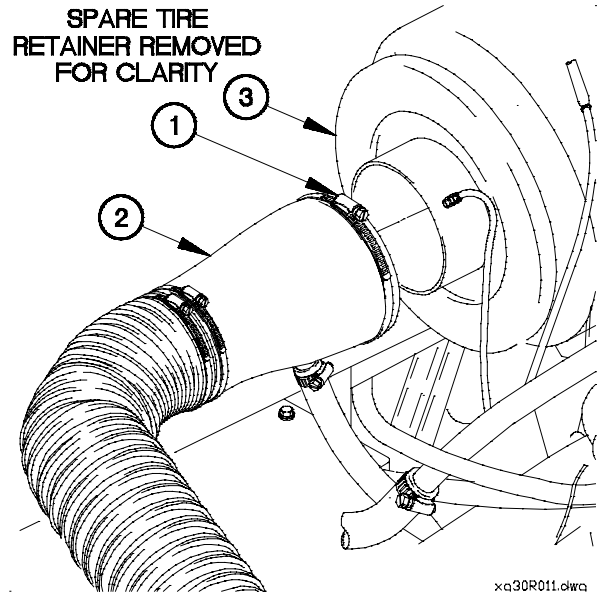

xα30R011.dwg

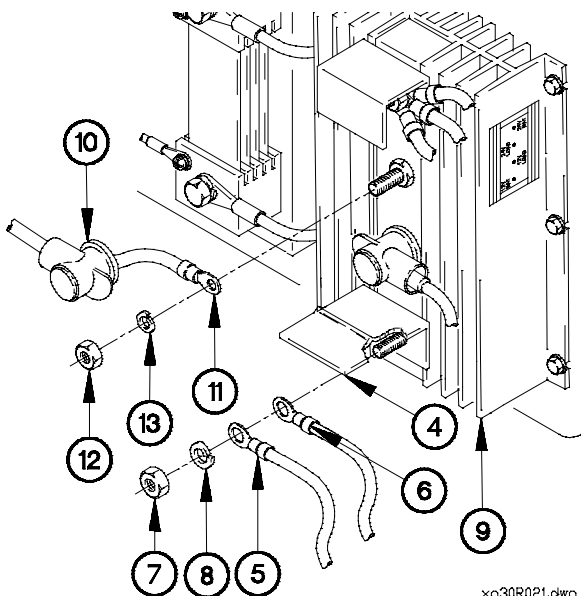

xα30R021.dwg

- (3) Lift terminal cover (4) on terminal lugs TL61 (5) and TL47 (6).
- (4) Remove nut (7), lockwasher (8) and terminal lugs TL61 (5) and TL47 (6) from 100 amp reverse polarity relay (9). Discard lockwasher.
- (5) Lift dust boot (10) on terminal lug TL44 (11).
- (6) Remove nut (12), lockwasher (13), and terminal lug TL44 (11) from 100 amp reverse polarity relay (9). Discard lockwasher.

- (7) Lift dust boot (14) on terminal lug TL80 (15).
- (8) Remove nut (16), lockwasher (17), and terminal lug TL80 (15) from 100 amp reverse polarity relay (9). Discard lockwasher.
- (9) Lift terminal cover (18) on terminal lugs TL1 (19), TL37 (20) and TL36 (21).
- (10) Remove nut (22), lockwasher (23), and terminal lugs TL1 (19), TL37 (20), and TL36 (21) from 100 amp reverse polarity relay (9). Discard lockwasher.

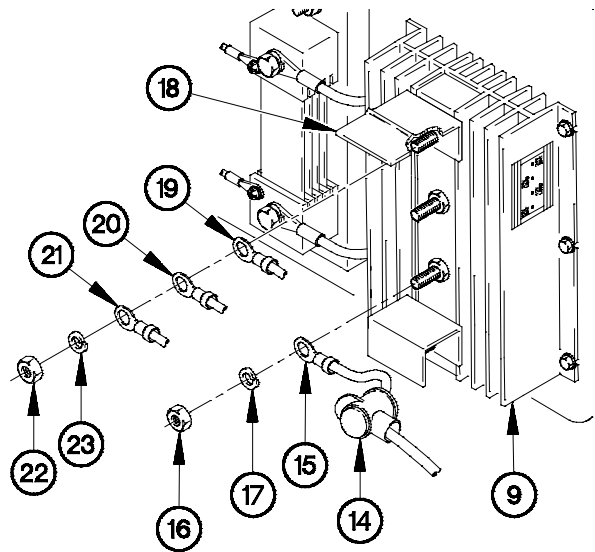

xa30R031.dwg

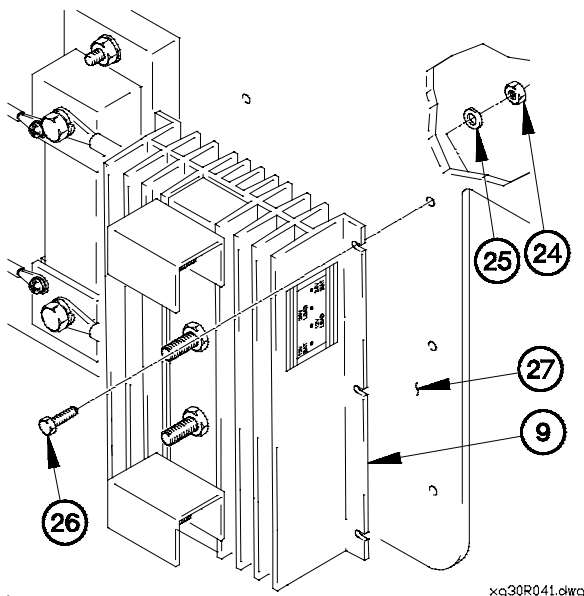

xa30R041.dwg

- (11) Remove six self-locking nuts (24), spring washers (25), screws (26), and 100 amp reverse polarity relay (9) from bracket (27). Discard spring washers and self-locking nuts.

b. Installation.

- (1) Position 100 amp reverse polarity relay (1) on bracket (2) with six screws (3), spring washers (4), and self-locking nuts (5).
- (2) Tighten six screws (3) to 60-72 lb-in. (7-8 N-m).

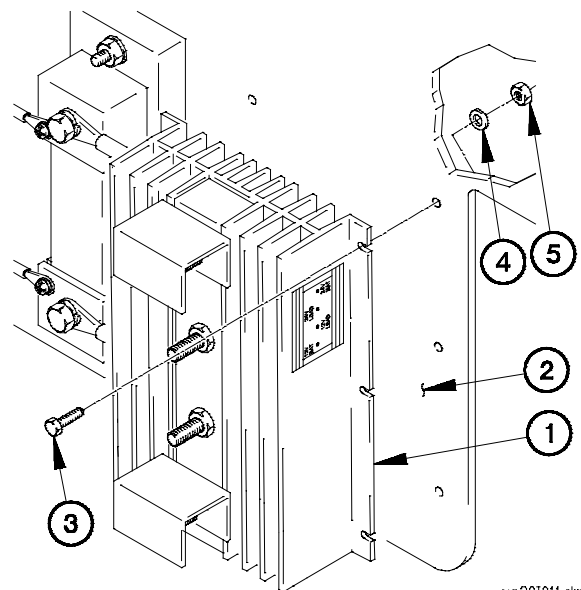

xa30I011.dwg

7-30. 100 AMP REVERSE POLARITY RELAY REPLACEMENT (CONT)

- (3) Position terminal lugs TL36 (6), TL37 (7), and TL1 (8) on 100 amp reverse polarity relay (1) with lockwasher (9) and nut (10).
- (4) Tighten nut (10) to 120-144 lb-in. (14-16 N-m).
- (5) Position terminal cover (11) on terminal lugs TL36 (6), TL37 (7), and TL1 (8).
- (6) Position terminal lug TL80 (12) on 100 amp reverse polarity relay (1) with lockwasher (13) and nut (14).
- (7) Tighten nut (14) to 120-144 lb-in. (14-16 N-m).
- (8) Position dust boot (15) on terminal lug TL80 (12).

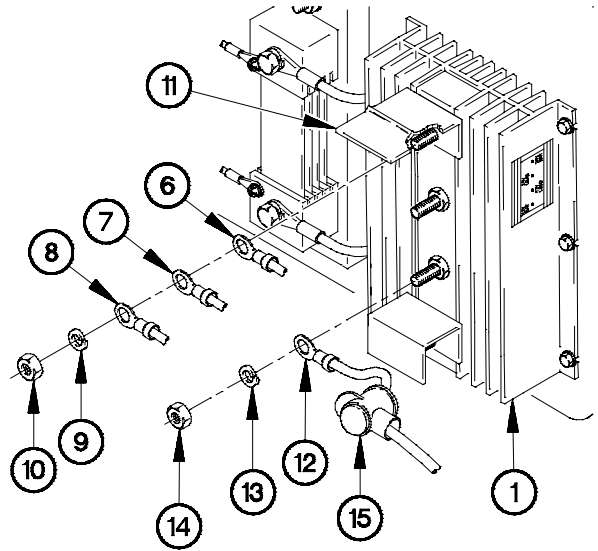

xa301021.dwg

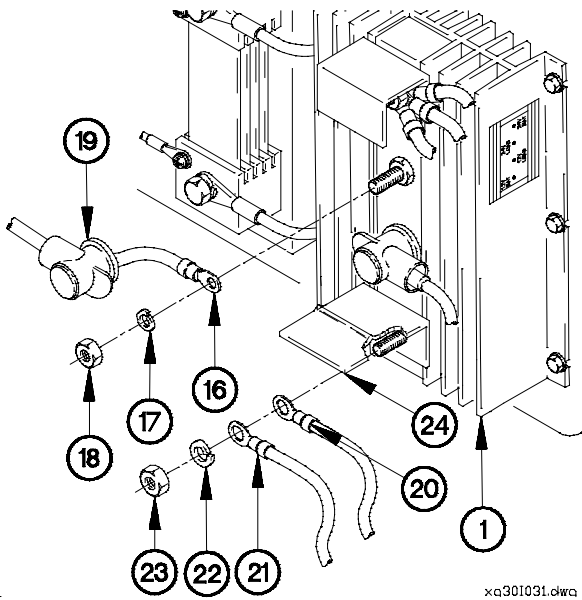

xa301031.dwg

- (9) Position terminal lug TL44 (16) on 100 amp reverse polarity relay (1) with lockwasher (17) and nut (18).
- (10) Tighten nut (18) to 120-144 lb-in. (14-16 N-m).
- (11) Position dust boot (19) on terminal lug TL44 (16).
- (12) Position terminal lug TL47 (20) and TL61 (21) on 100 amp reverse polarity relay (1) with lockwasher (22) and nut (23).
- (13) Tighten nut (23) to 120-144 lb-in. (14-16 N-m).
- (14) Position terminal cover (24) on terminal lugs TL47 (20) and TL61 (21).

- (15) Position intake air cleaner boot (25) on intake air cleaner housing (26) with clamp (27).
- (16) Tighten clamp (27) to 36-48 lb-in. (4-5 N·m).

c. Follow-On Maintenance.

- (1) Connect batteries (para 7-57).
- (2) Raise spare tire (TM 9-2320-366-10-2).
- (3) Start engine (TM 9-2320-366-10-1).
- (4) Check VOLTS gage for charge indication (TM 9-2320-366-10-1).
- (5) Shut down engine (TM 9-2320-366-10-1).

End of Task.

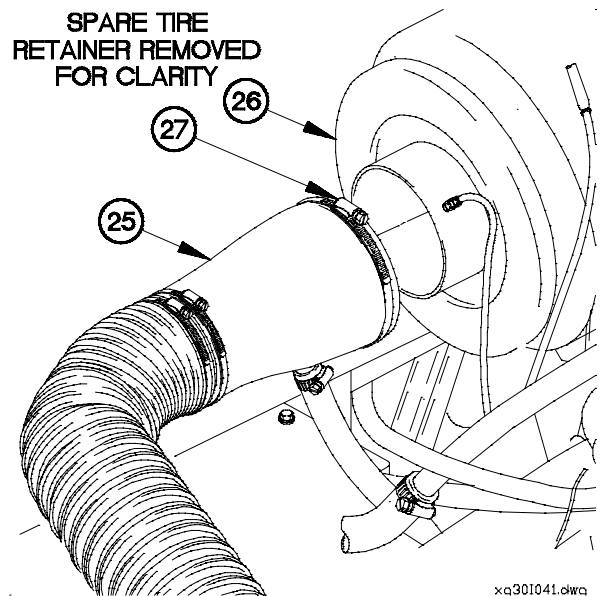

7-31. FREQUENCY ECU REPLACEMENT

This task covers:

- a. Removal
- b. Installation
- c. Follow-On Maintenance

INITIAL SETUP

Equipment Conditions

Instrument panel assembly removed for access (para 7-15).

Tools and Special Tools

Tool Kit, Genl Mech (Item 46, Appendix C)

a. Removal.

- (1) Disconnect frequency ECU connector (1) from connector PX26 (2).
- (2) Remove two screws (3) and frequency ECU (4) from bracket (5).

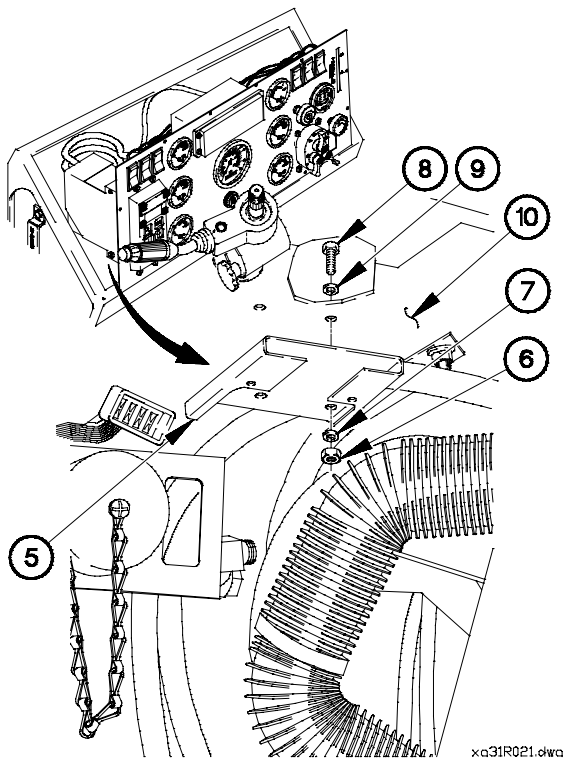
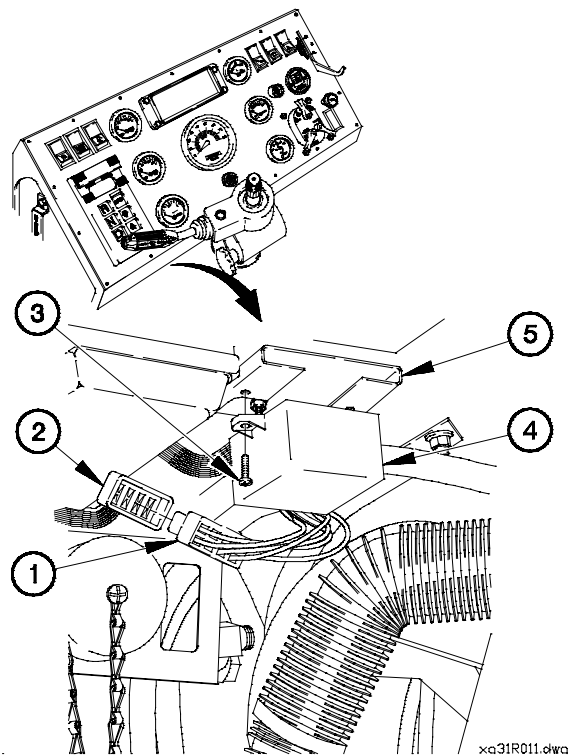

- (3) Remove two nuts (6), washers (7), screws (8), washers (9), and bracket (5) from dashboard (10).

b. Installation.

- (1) Install bracket (1) on dashboard (2) with two washers (3), screws (4), washers (5), and nuts (6).

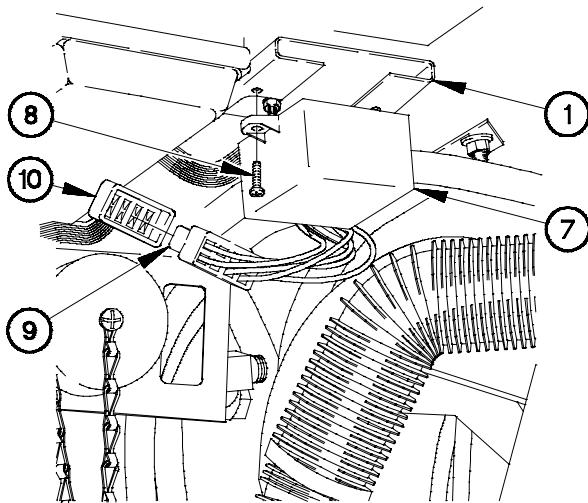
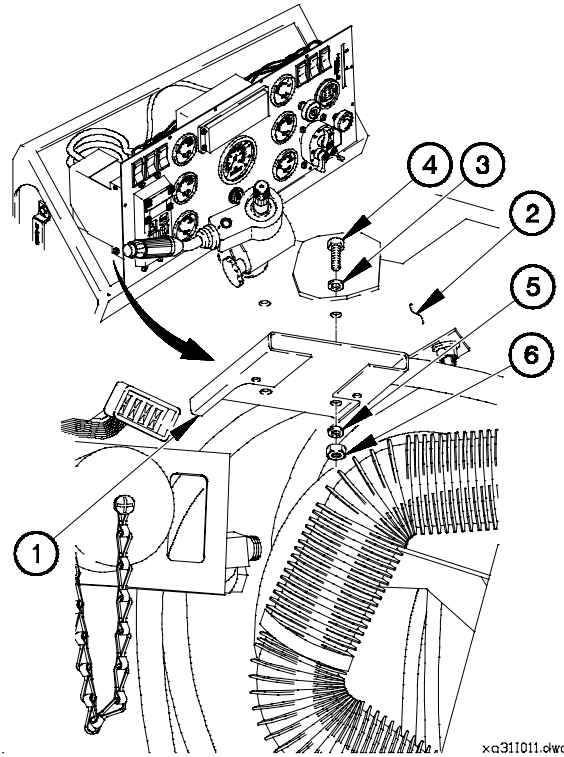

- (2) Install frequency ECU (7) on bracket (1) with two screws (8).
- (3) Connect frequency ECU connector (9) to connector PX26 (10).

c. Follow-On Maintenance.

Install instrument panel assembly (para 7-15).

End of Task.

7-32. REMOTE CONTROL UNIT REPAIR

This task covers:

- | | |
|-------------------------------|--------------------------|
| a. Controller Removal | e. Harness Removal |
| b. Controller Installation | f. Harness Installation |
| c. Toggle Switch Removal | g. Follow-On Maintenance |
| d. Toggle Switch Installation | |

INITIAL SETUP

Equipment Conditions

MHC remote control unit removed (TM 9-2320-366-10-1 or TM 9-2320-366-10-2).

Tools and Special Tools

Tool Kit, Genl Mech (Item 46, Appendix C)
Wrench, Torque, 0-75 lb-in. (Item 90, Appendix B)

Materials/Parts

Dispenser, Pressure Sensitive Adhesive Tape (Item 20, Appendix D)
Adhesive (Item 5, Appendix D)
Nut, Self-Locking (4) (Item 175, Appendix G)

a. Controller Removal.

NOTE

All four controllers are removed the same way. Boom Up/Down controller shown.

- (1) Remove four self-locking nuts (1) from boom up/down controller (2). Discard self-locking nuts.
- (2) Remove boom up/down controller (2) from REMOTE CONTROL UNIT (3) until connector (4) is accessible.
- (3) Disconnect connector (4) from boom up/down controller (2).
- (4) Remove adhesive from seating surface (5).
- (5) Loosen jam nut (6) on boom up/down controller (2).
- (6) Remove knob (7) from boom up/down controller (2).
- (7) Remove jam nut (6) from boom up/down controller (2).

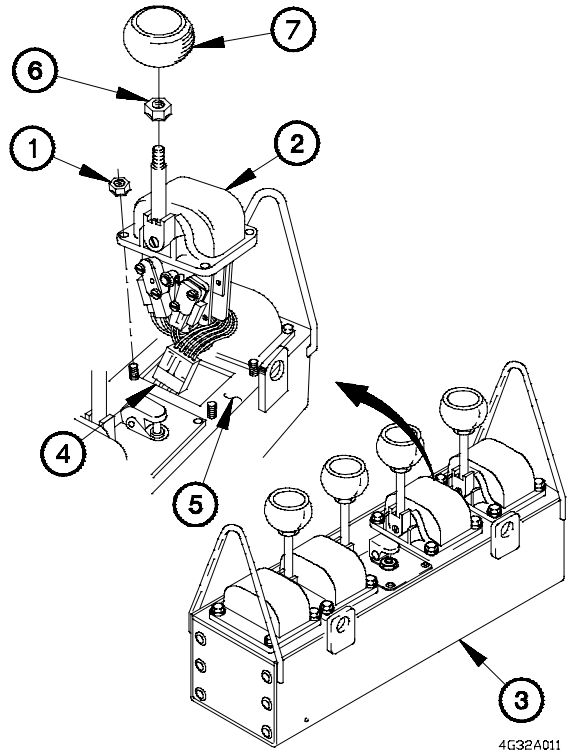

b. Controller Installation.

NOTE

All four controllers are installed the same way. Boom Up/Down controller shown.

- (1) Install jam nut (1) on boom up/down controller (2).
- (2) Install knob (3) on boom up/down controller (2).
- (3) Tighten jam nut (1) against knob (3).

WARNING

Adhesives, solvents, and sealing compounds can burn easily, can give off harmful vapors, and are harmful to skin and clothing. Keep away from open fire and use in a well-ventilated area. If adhesive, solvent, or sealing compound gets on skin or clothing, wash immediately with soap and water. Failure to comply may result in injury to personnel.

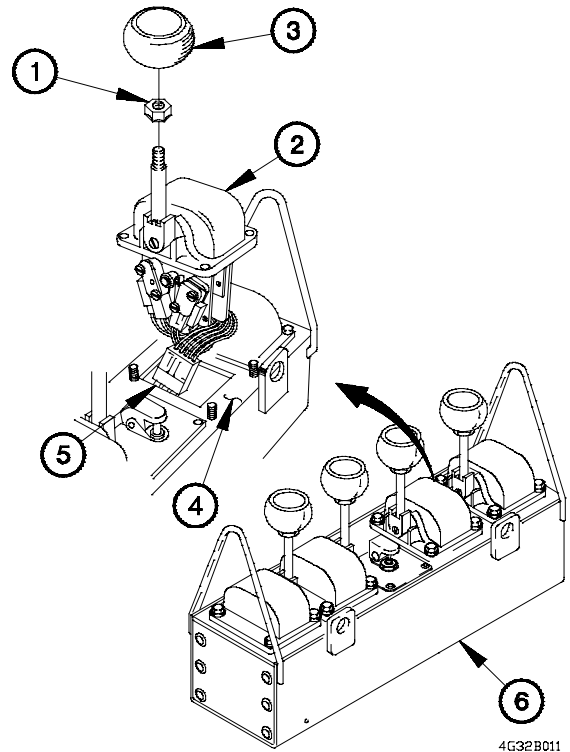

4G32B011

- (4) Apply adhesive to seating surface (4).
- (5) Connect connector (5) to boom up/down controller (2).
- (6) Position boom up/down controller (2) in REMOTE CONTROL UNIT (6).

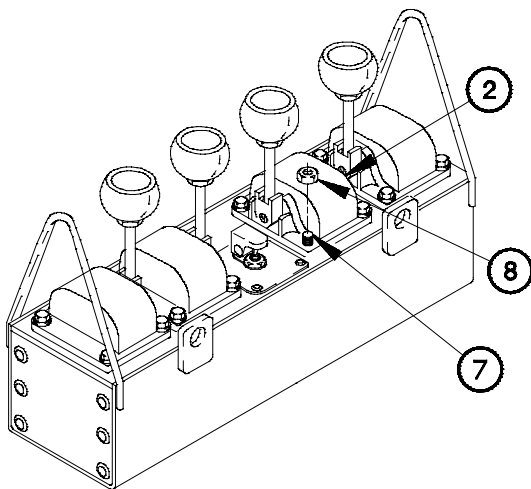

4G32B021

- (7) Apply adhesive to the first 2 to 5 threads of mounting studs (7).
- (8) Position four self-locking nuts (8) on boom up/down controller (2).
- (9) Tighten four self-locking nuts (8) to 14 lb-in. (2 N·m).

NOTE

Adhesive requires 24 hours to cure.

- (10) Spread excess adhesive over heads of four self-locking nuts (8).

7-32. REMOTE CONTROL UNIT REPAIR (CONT)

c. Toggle Switch Removal.

NOTE

One controller needs to be removed for access to toggle switch. Boom Up/Down controller shown.

- (1) Remove four self-locking nuts (1) from boom up/down controller (2). Discard self-locking nuts.
- (2) Remove boom up/down controller (2) from REMOTE CONTROL UNIT (3) until connector (4) is accessible.
- (3) Disconnect connector (4) from boom up/down controller (2).
- (4) Remove adhesive from seating surface (5).

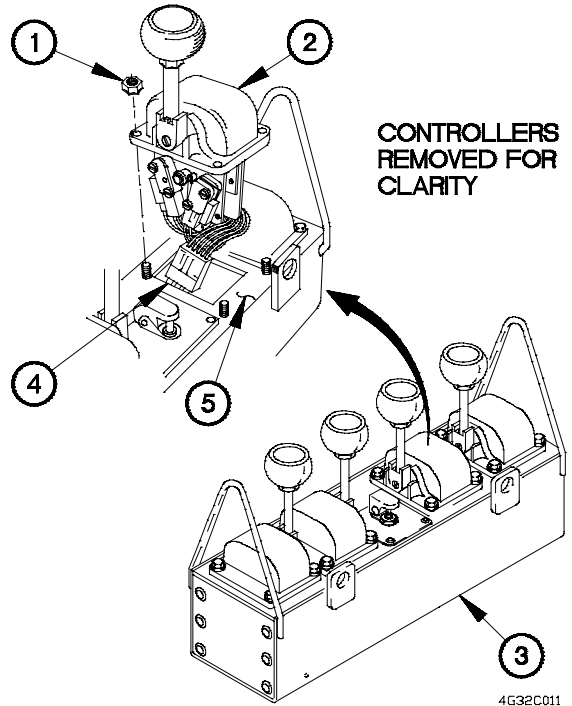

- (5) Remove nut (6), nylon washer (7), and switch guard cover (8) from toggle switch (9).

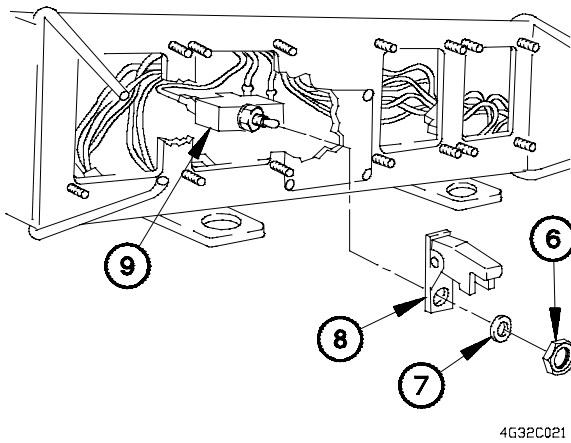

- (6) Remove toggle switch (9) from REMOTE CONTROL UNIT (3) until four wires (10) are accessible.

NOTE

Tag wires and connection points prior to disconnecting.

- (7) Disconnect four wires (10) from toggle switch (9).

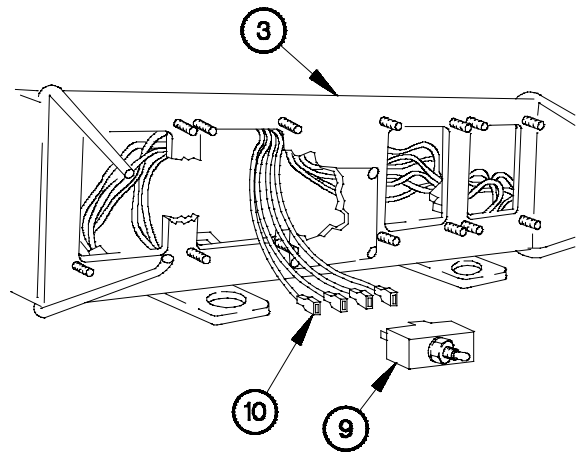

d. Toggle Switch Installation.

- (1) Connect four wires (1) to toggle switch (2).

NOTE

Keyway of toggle switch aligns with keyway slot in mounting hole.

- (2) Position toggle switch (2) in mounting hole (3).

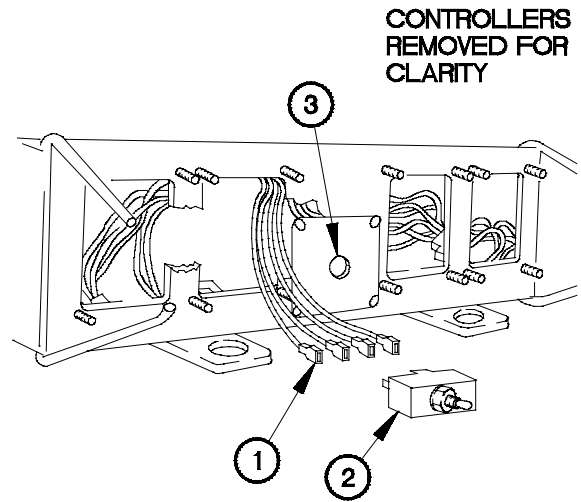

4G32D011

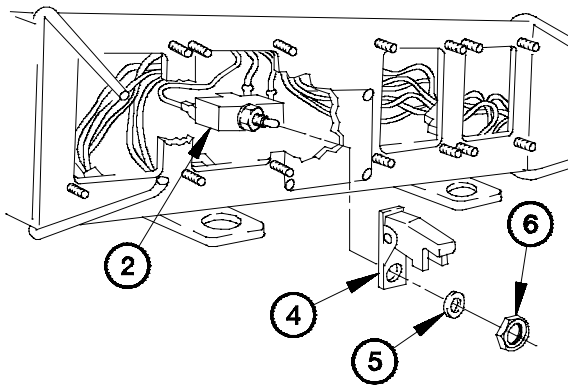

4G32D021

- (3) Install switch guard cover (4) on toggle switch (2) with nylon washer (5) and nut (6).

WARNING

Adhesives, solvents, and sealing compounds can burn easily, can give off harmful vapors, and are harmful to skin and clothing. Keep away from open fire and use in a well-ventilated area. If adhesive, solvent, or sealing compound gets on skin or clothing, wash immediately with soap and water. Failure to comply may result in injury to personnel.

- (4) Apply adhesive to seating surface (7).
- (5) Connect connector (8) to boom up/down controller (9).
- (6) Position boom up/down controller (9) in REMOTE CONTROL UNIT (10).

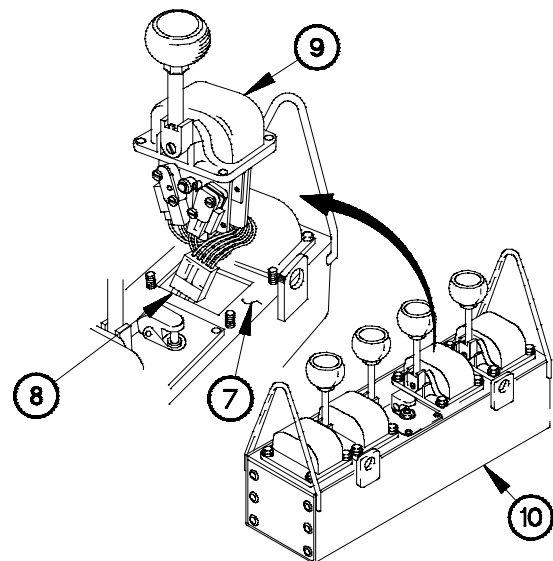

4G32D031

7-32. REMOTE CONTROL UNIT REPAIR (CONT)

WARNING

Adhesives, solvents, and sealing compounds can burn easily, can give off harmful vapors, and are harmful to skin and clothing. Keep away from open fire and use in a well-ventilated area. If adhesive, solvent, or sealing compound gets on skin or clothing, wash immediately with soap and water. Failure to comply may result in injury to personnel.

- (7) Apply adhesive to the first 2 to 5 threads of mounting studs (11).
- (8) Position four self-locking nuts (12) on boom up/down controller (9).
- (9) Tighten four self-locking nuts (12) to 14 lb-in. (2 N·m).

NOTE

Adhesive requires 24 hours to cure.

- (10) Spread excess adhesive over heads of four self-locking nuts (12).

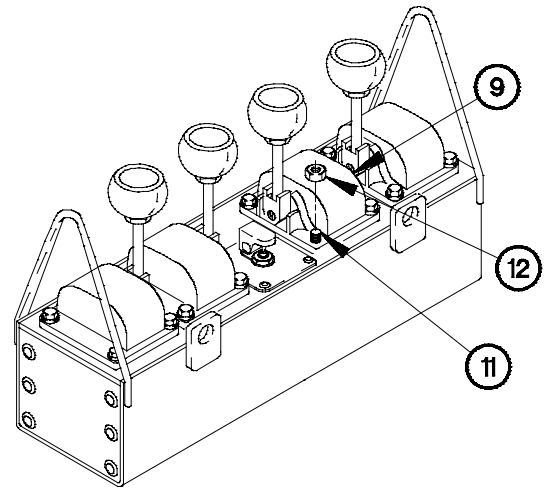

4G32D041

e. Harness Removal.

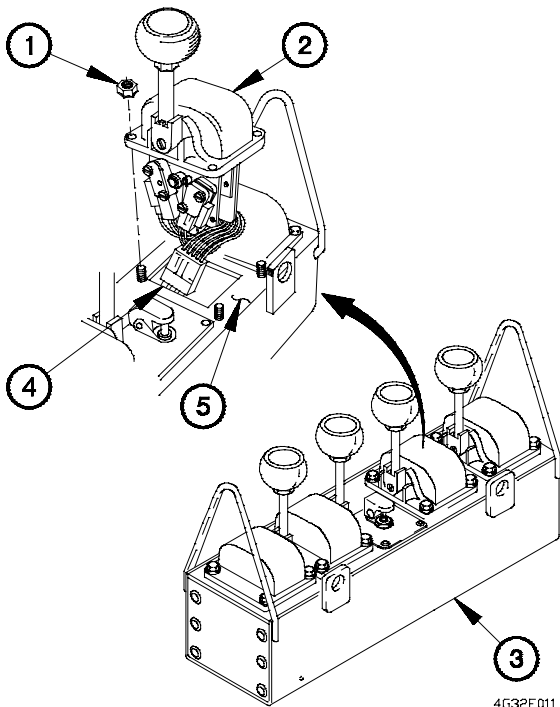

4G32E011

NOTE

- All four controllers are removed for harness removal.
 - All four controllers are removed the same way. Boom Up/Down controller shown.
- (1) Remove four self-locking nuts (1) from boom up/down controller (2). Discard self-locking nuts.
 - (2) Remove boom up/down controller (2) from REMOTE CONTROL UNIT (3) until connector (4) is accessible.
 - (3) Disconnect connector (4) from boom up/down controller (2).
 - (4) Remove adhesive from seating surface (5).

- (5) Remove nut (6), nylon washer (7), and switch guard cover (8) from toggle switch (9).

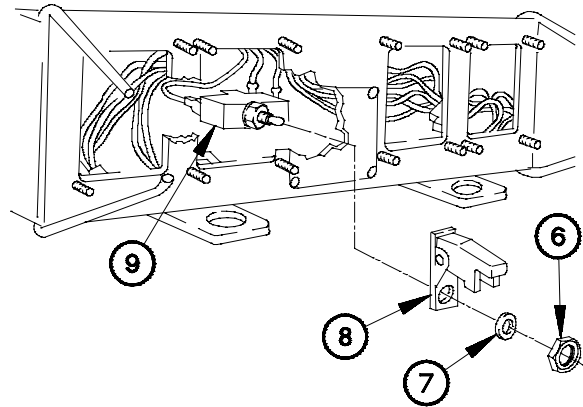

4G32E021

- (6) Remove toggle switch (9) from REMOTE CONTROL UNIT (3) until four wires (10) are accessible.

NOTE

Tag wires and connection points prior to disconnecting.

- (7) Disconnect four wires (10) from toggle switch (9).

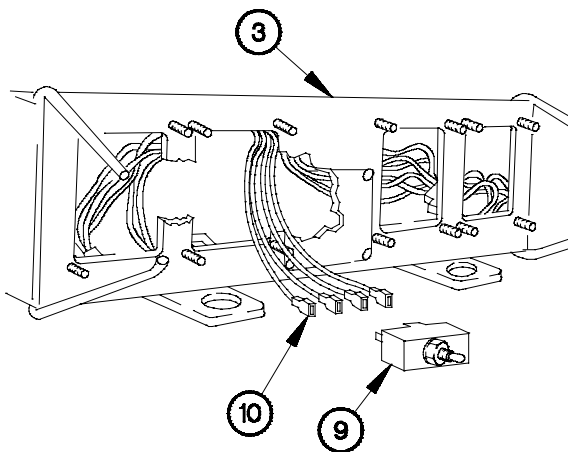

4G32E031

- (8) Disconnect harness ground wire (11) from ground tab (12).
- (9) Remove dust cap (13) from receptacle (14).
- (10) Remove nut (15) and washer (16) from receptacle (14).
- (11) Remove harness (17) from REMOTE CONTROL UNIT (3).

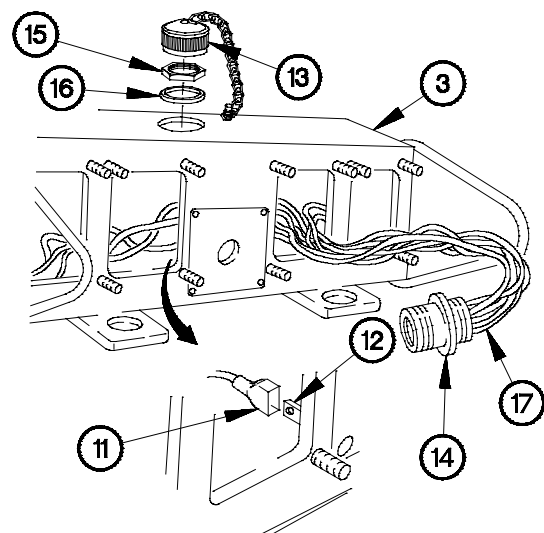

4G32E041

7-32. REMOTE CONTROL UNIT REPAIR (CONT)

f. Harness Installation.

- (1) Position harness (1) in REMOTE CONTROL UNIT (2).
- (2) Install receptacle (3) with washer (4) and nut (5) on REMOTE CONTROL UNIT (2).
- (3) Connect harness ground wire (6) to ground tab (7).
- (4) Install dust cap (8) on receptacle (3).

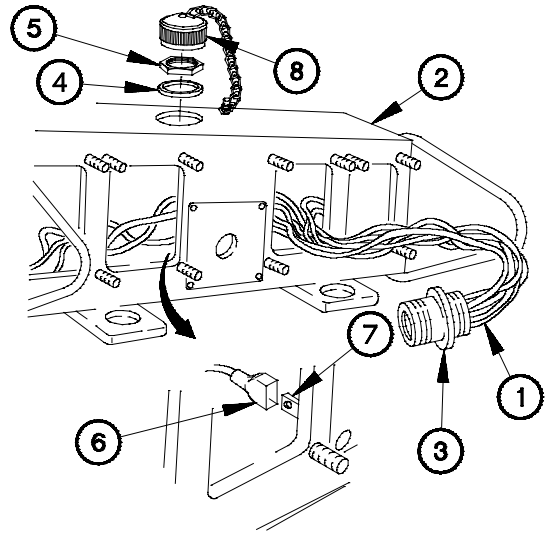

4G32F011

- (5) Connect four wires (9) to toggle switch (10).

NOTE

Keyway of toggle switch aligns with keyway slot in mounting hole.

- (6) Position toggle switch (10) in mounting hole (11).

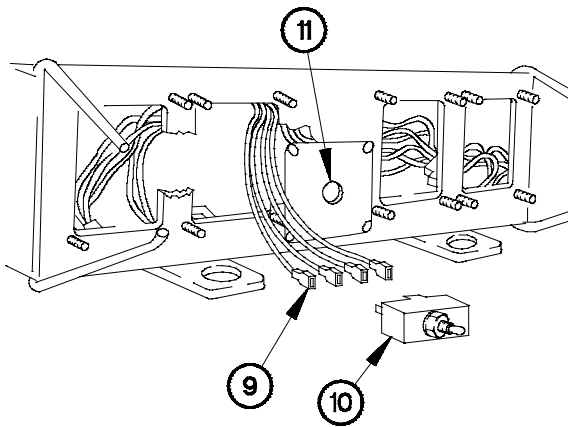

4G32F021

- (7) Install switch guard cover (12) on toggle switch (10) with nylon washer (13) and nut (14).

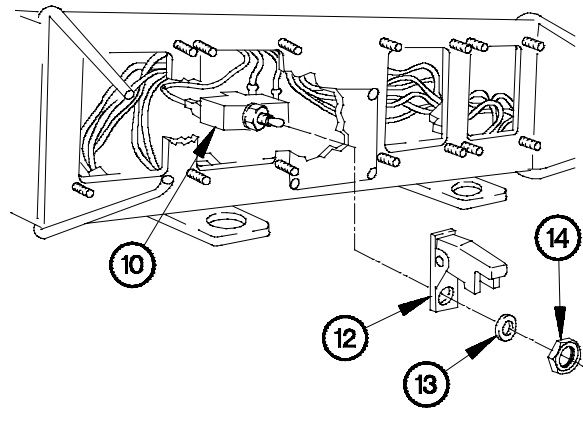

4G32F031

WARNING

Adhesives, solvents, and sealing compounds can burn easily, can give off harmful vapors, and are harmful to skin and clothing. Keep away from open fire and use in a well-ventilated area. If adhesive, solvent, or sealing compound gets on skin or clothing, wash immediately with soap and water. Failure to comply may result in injury to personnel.

NOTE

All four controllers are installed the same way. Boom Up/Down controller shown.

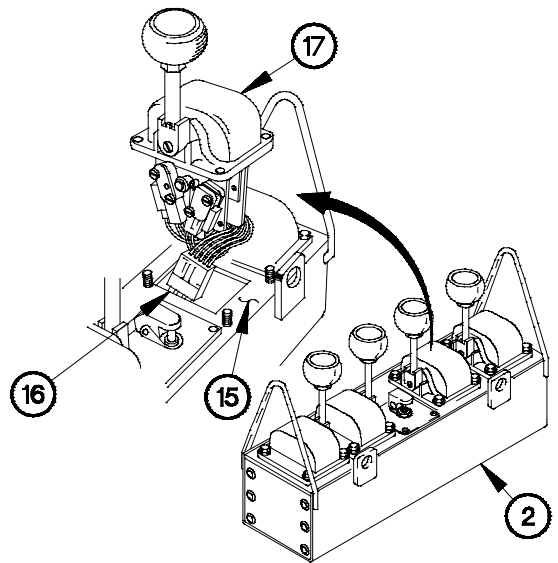

4G32F041

- (8) Apply adhesive to seating surface (15).
- (9) Connect connector (16) to boom up/down controller (17).
- (10) Position boom up/down controller (17) in REMOTE CONTROL UNIT (2).

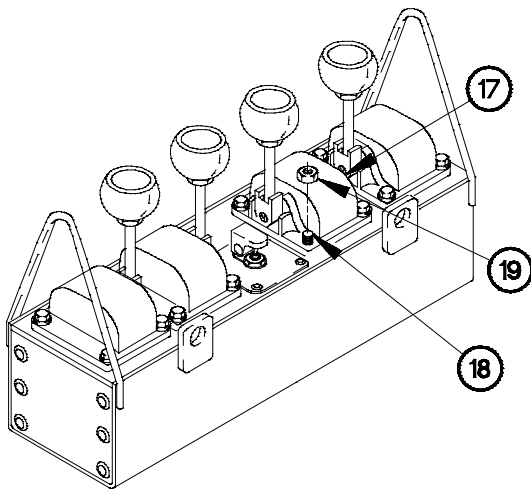

4G32F051

- (11) Apply adhesive to the first 2 to 5 threads of mounting studs (18).
- (12) Position four self-locking nuts (19) on boom up/down controller (17).
- (13) Tighten four self-locking nuts (19) to 14 lb-in. (2 N·m).

NOTE

Adhesive requires 24 hours to cure.

- (14) Spread excess adhesive over heads of four self-locking nuts (19).

g. Follow-On Maintenance.

Operate crane using REMOTE CONTROL UNIT (TM 9-2320-366-10-1 or TM 9-2320-366-10-2).

End of Task.

7-33. M1089 TERMINAL BLOCK REPLACEMENT

This task covers:

- a. Removal
- b. Installation
- c. Follow-On Maintenance

INITIAL SETUP

Equipment Conditions

Engine shut down (TM 9-2320-366-10-1).
 Batteries disconnected (para 7-57).

Tools and Special Tools

Tool Kit, Genl Mech (Item 46, Appendix C)

Material/Parts

Dispenser, Pressure Sensitive Adhesive Tape (Item 20, Appendix D)
 Nut, Self-Locking (2) (Item 133, Appendix G)
 Lockwasher (8) (Item 100, Appendix G)
 Nut, Self-Locking (2) (Item 128, Appendix G)

a. Removal.

- (1) Remove two self-locking nuts (1), four washers (2), and two screws (3) from top cover (4). Discard self-locking nuts.
- (2) Remove eight screws (5), lockwashers (6), washers (7), and top cover (4) from control panel (8). Discard lockwashers.

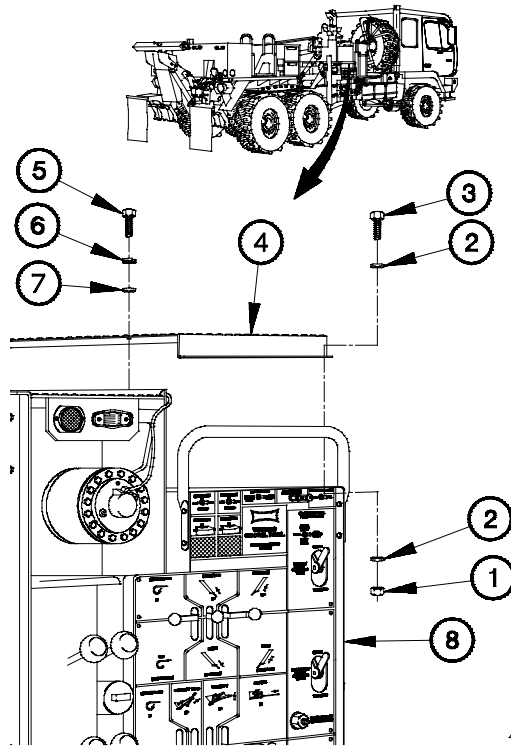

4G33R01B

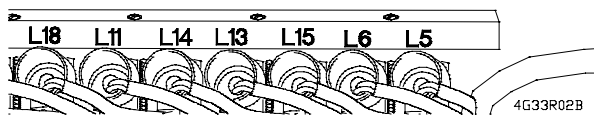
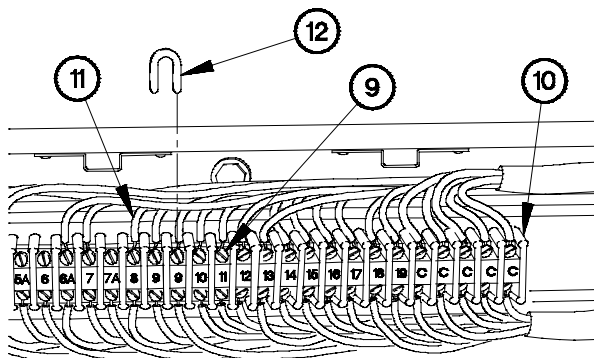

NOTE

- Remove plastic cable ties as required.
 - Tag and record wires, terminal block jumpers and connection points prior to disconnecting.
- (3) Loosen screws (9) on top of terminal blocks (10).
 - (4) Remove wires (11) from top of terminal blocks (10).
 - (5) Remove five terminal block jumpers (12) from top of terminal blocks (10).

- (6) Remove two self-locking nuts (13), screws (14), washers (15), and channel (16) from winch assembly (17). Discard self-locking nuts.

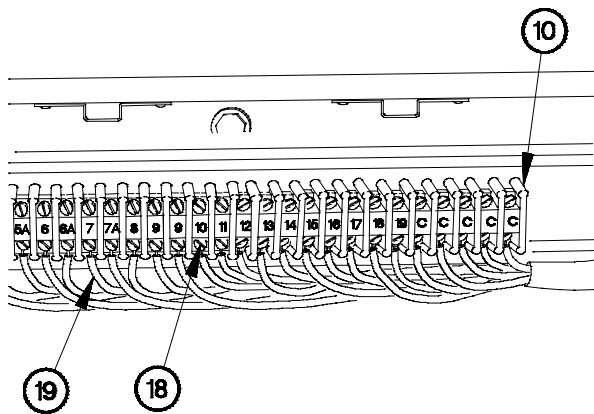
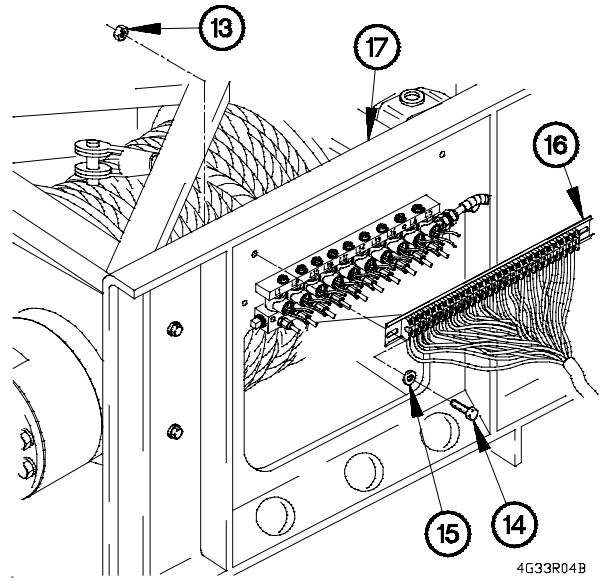

- (7) Loosen screws (18) on bottom of terminal blocks (10).
 (8) Remove wires (19) from bottom of terminal blocks (10).

7-33. M1089 TERMINAL BLOCK REPLACEMENT (CONT)

(9) Loosen screw (20) in two clamps (21).

NOTE

Record position of terminal blocks prior to removal.

(10) Remove two clamps (21), end cap (22) and 28 terminal blocks (10) from channel (16).

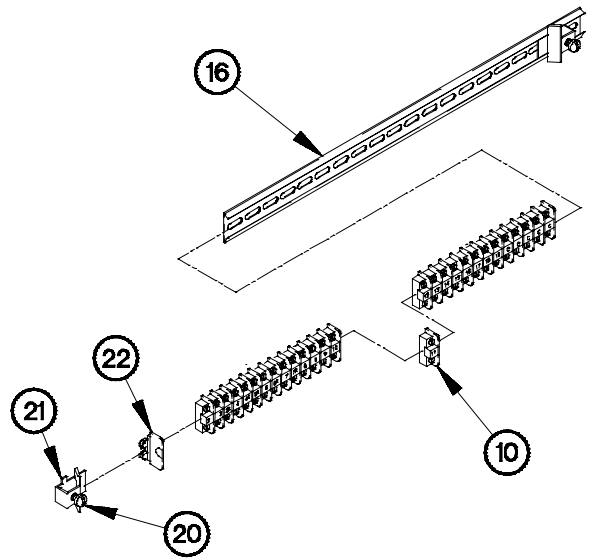

4G33R05B

b. Installation.

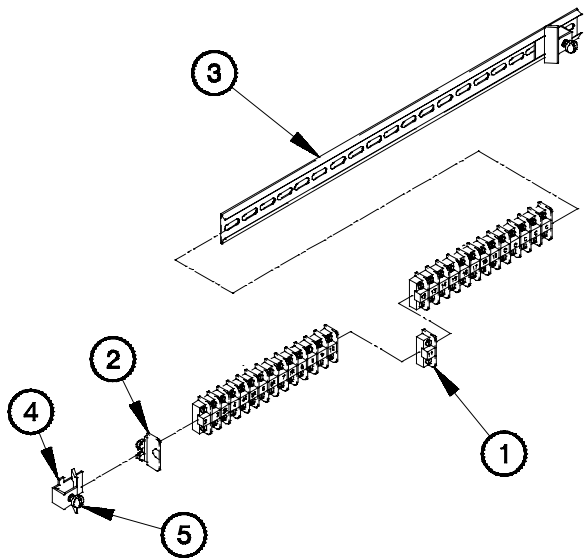

4G33I01B

- (1) Label 28 terminal blocks (1) as recorded in removal.
- (2) Position 28 terminal blocks (1), end cap (2) on channel (3) with two clamps (4).
- (3) Tighten screw (5) in two clamps (4).

- (4) Position wires (6) on bottom of terminal blocks (1) as recorded in removal.
- (5) Tighten screws (7) on bottom of terminal blocks (1).

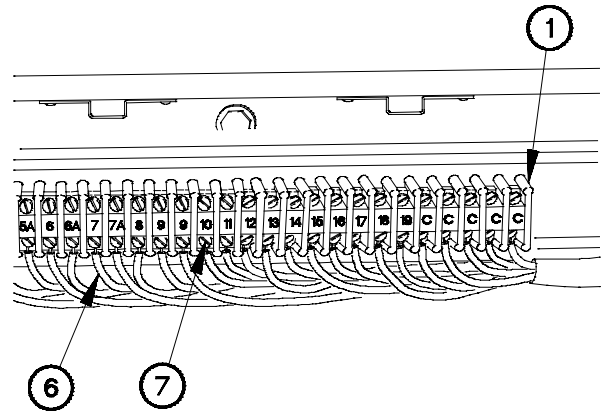

4G33103B

- (6) Install channel (3) on winch assembly (8) with two washers (9), screws (10), and self-locking nuts (11).

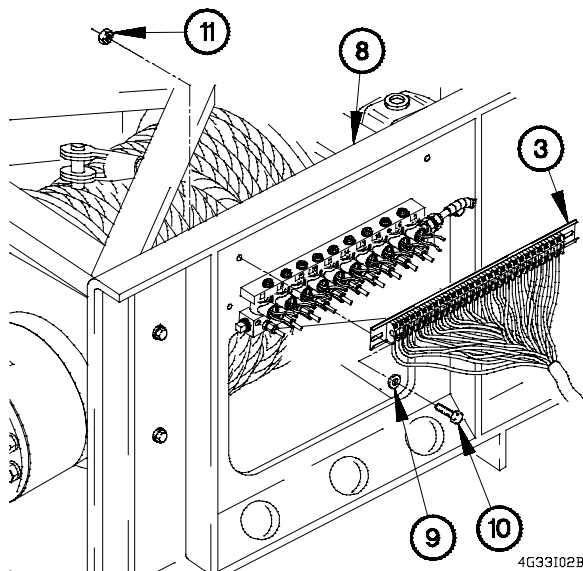

4G33102B

- (7) Position five terminal block jumpers (12) on top of terminal blocks (1) as recorded in removal.

NOTE

Install plastic cable ties as required.

- (8) Position wires (13) on top of terminal blocks (1) as recorded in removal.
- (9) Tighten screws (14) on top of terminal blocks (1).

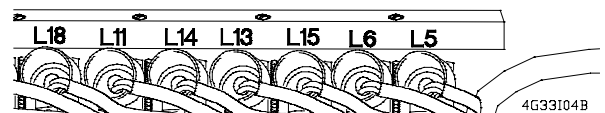
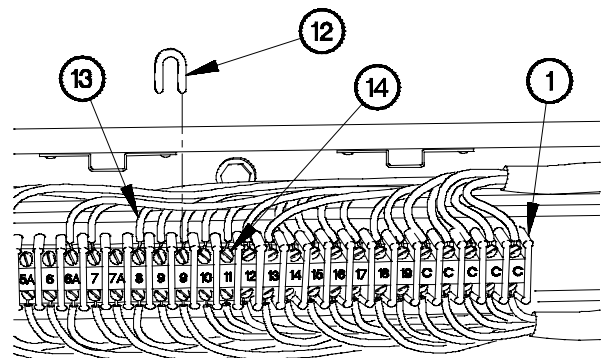

4G33104B

- (10) Install top cover (15) on control panel (16) with eight washers (17), lockwashers (18), and screws (19).
- (11) Install four washers (20), two screws (21), and self-locking nuts (22) in top cover (15).

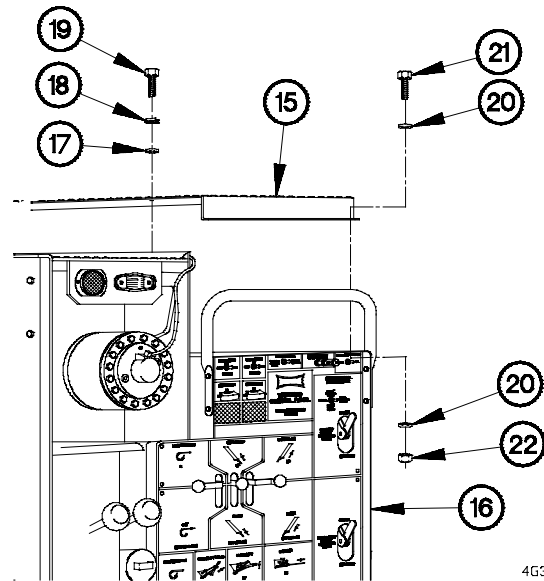

4G33105B

c. Follow-On Maintenance.

- (1) Connect batteries (para 7-57).
- (2) Operate all wrecker functions and check for proper operation (TM 9-2320-366-10-1).

End of Task.

7-34. M1089 WRECKER CONTROL PANEL TOGGLE SWITCH REPLACEMENT

This task covers:

- a. Removal
- b. Installation
- c. Follow-On Maintenance

INITIAL SETUP

Equipment Conditions

Engine shut down (TM 9-2320-366-10-1).
 Batteries disconnected (para 7-57).

Tools and Special Tools

Tool Kit, Genl Mech (Item 46, Appendix C)
 Tool Kit, Electrical (Item 45, Appendix C)
 Heater, Gun Type, Electric (Item 24, Appendix B)

Material/Parts

Dispenser, Pressure Sensitive Adhesive Tape (Item 20, Appendix D)
 Insulation Sleeving, Electrical (Item 29, Appendix D)
 Lockwasher (8) (Item 100, Appendix G)
 Lockwasher (Item 74, Appendix G)
 Nut, Self-Locking (2) (Item 134, Appendix G)
 Splice, Conductor (2) (Item 275, Appendix G)
 Splice, Conductor (Item 276, Appendix G)

a. Removal.

NOTE

There are seven toggle switches on the WRECKER CONTROL PANEL. Steps (1 and 2) apply to all seven toggle switches.

- (1) Remove eight screws (1), lockwashers (2), and washers (3) from control panel top cover (4). Discard lockwashers.
- (2) Remove two self-locking nuts (5), four washers (6), two screws (7), and control panel top cover (4) from WRECKER CONTROL PANEL (8). Discard self-locking nuts.

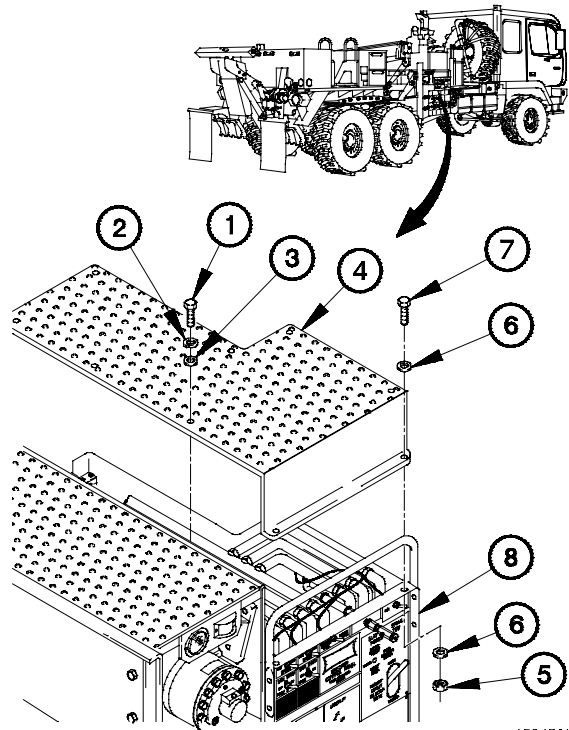

4G34R011

NOTE

- Steps (3 and 4) apply only to the MAIN WINCH LH FREE SPOOL and MAIN WINCH RH FREE SPOOL toggle switches. MAIN WINCH LH FREE SPOOL toggle switch shown.
 - Tag wires and connection points prior to disconnecting.
- (3) Remove nut (9), lockwasher (10), switch cover (11), nut (12), tab washer (13), and MAIN WINCH LH FREE SPOOL toggle switch (14) from WRECKER CONTROL PANEL (8). Discard lockwasher.
 - (4) Remove two screws (15) and terminal lugs (16) from MAIN WINCH LH FREE SPOOL toggle switch (14).

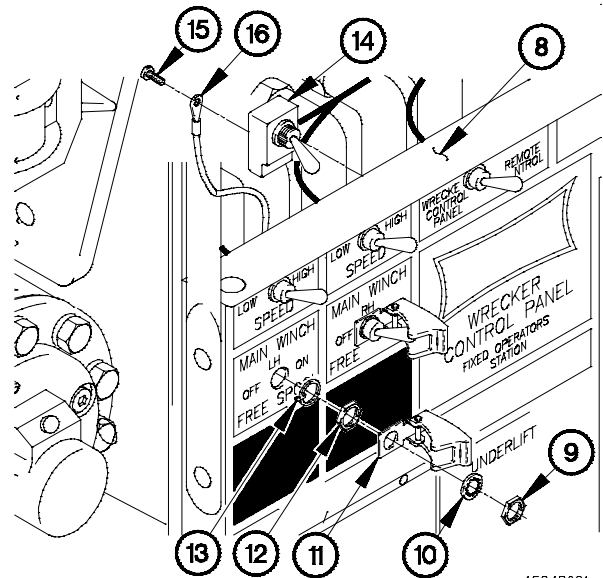

4G34R021

CAUTION

Switch covers contain an integral nut. Do not attempt to pull switch cover off toggle switch. Failure to comply will result in damage to equipment.

NOTE

Steps (5 through 9) apply to the remaining five toggle switches. Two toggle switches have three electrical connections, the remaining three have only two electrical connections. EMERGENCY SHUTDOWN toggle switch shown.

- (5) Remove switch cover nut (17) and EMERGENCY SHUTDOWN toggle switch (18) from WRECKER CONTROL PANEL (8).

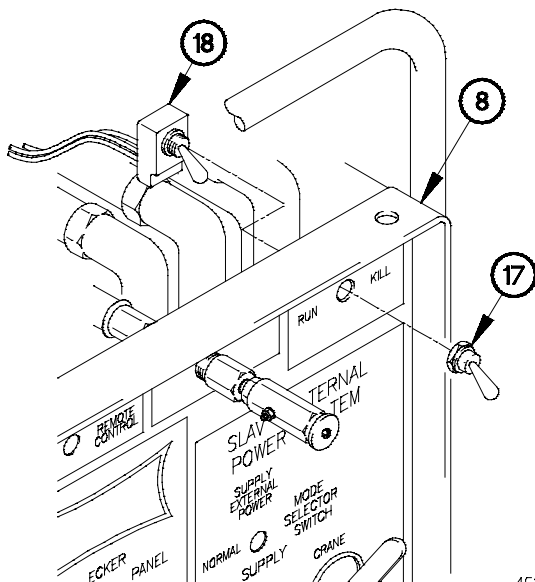

4G34R031

7-34. M1089 WRECKER CONTROL PANEL TOGGLE SWITCH REPLACEMENT (CONT)

- (6) Disconnect conductor splice (19) from two wires (20).
- (7) Remove conductor splice (21) and EMERGENCY SHUTDOWN toggle switch (18) from wire (22).
- (8) Remove conductor splices (19 and 21) from EMERGENCY SHUTDOWN toggle switch (18). Discard conductor splices.

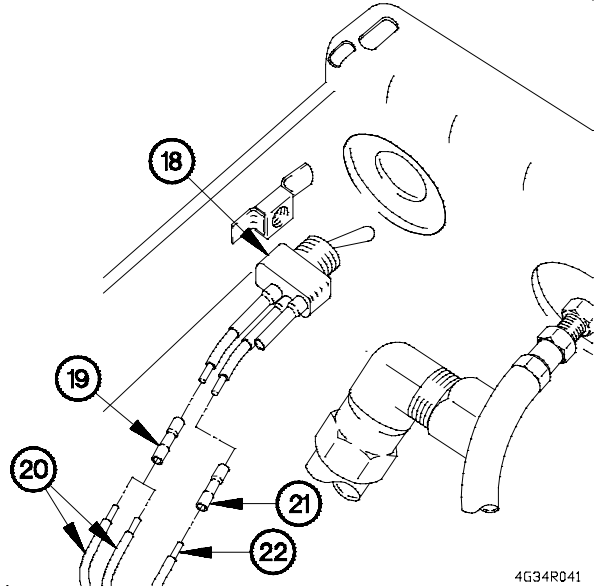

b. Installation.

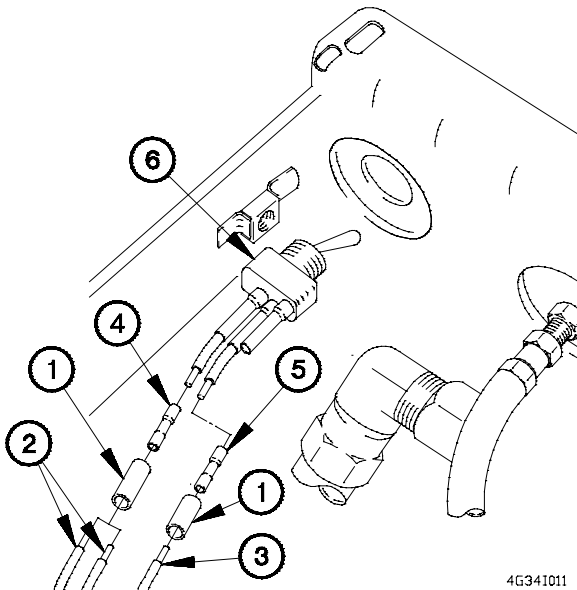

NOTE

Steps (1 through 6) apply to the remaining five toggle switches. Two toggle switches have three electrical connections, the remaining three have only two electrical connections. EMERGENCY SHUTDOWN toggle switch shown.

- (1) Position insulation sleeving (1) over two wires (2).
- (2) Position insulation sleeving (1) over wire (3).
- (3) Install conductor splices (4 and 5) on EMERGENCY SHUTDOWN toggle switch (6).
- (4) Install conductor splice (5) on wire (3).
- (5) Install conductor splice (4) on two wires (2).

- (6) Install EMERGENCY SHUTDOWN toggle switch (6) in WRECKER CONTROL PANEL (7) with switch cover nut (8).

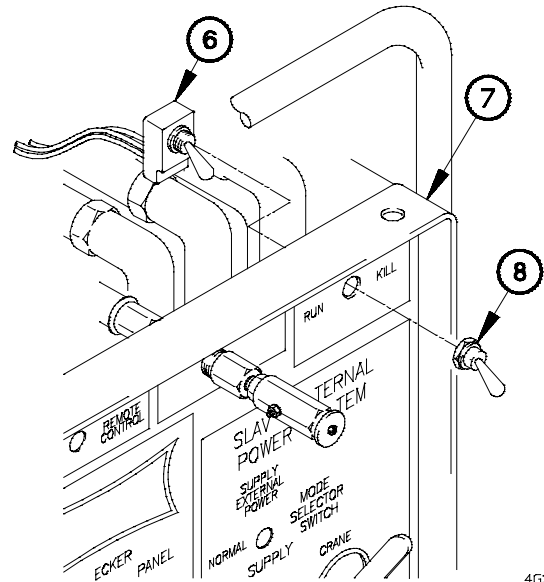

4G341021

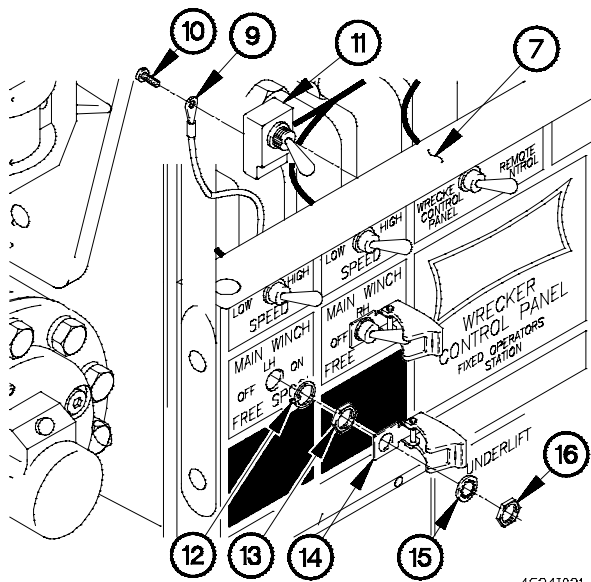

4G341031

NOTE

Steps (7) and (8) apply only to the MAIN WINCH LH FREE SPOOL and MAIN WINCH RH FREE SPOOL toggle switches. MAIN WINCH LH FREE SPOOL toggle switch shown.

- (7) Install two terminal lugs (9) and screws (10) on MAIN WINCH LH FREE SPOOL toggle switch (11).
- (8) Install MAIN WINCH LH FREE SPOOL toggle switch (11) in WRECKER CONTROL PANEL (7) with tab washer (12), nut (13), switch cover (14), lockwasher (15), and nut (16).

7-34. M1089 WRECKER CONTROL PANEL TOGGLE SWITCH REPLACEMENT (CONT)

- (9) Install control panel top cover (17) on WRECKER CONTROL PANEL (7) with four washers (18), two screws (19), and self-locking nuts (20).
- (10) Install eight washers (21), lockwashers (22), and screws (23) in control panel top cover (17).

c. Follow-On Maintenance.

- (1) Connect batteries (para 7-57).
- (2) Operate function of toggle switch that was replaced (TM 9-2320-366-10-1) and check for proper operation.

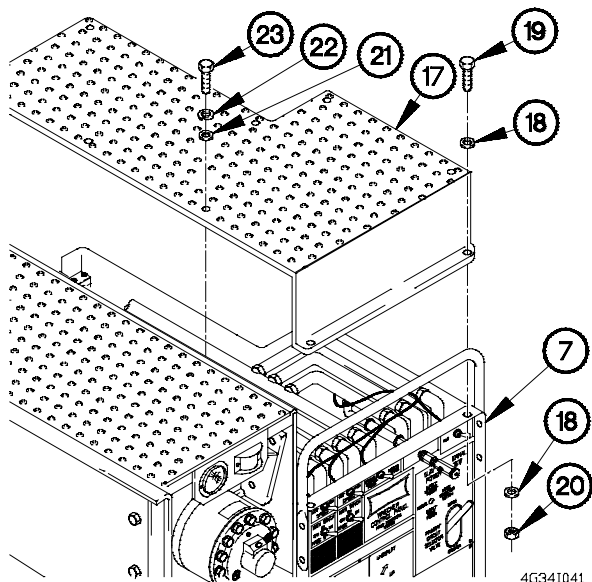

End of Task.

7-35. M1089 WRECKER REMOTE CONTROL REPAIR	
This task covers:	
a. Disassembly b. Assembly	c. Follow-On Maintenance
INITIAL SETUP	
Equipment Conditions REMOTE CONTROL assembly removed (TM 9-2320-366-10-1).	Materials/Parts Dispenser, Pressure Sensitive Adhesive Tape (Item 20, Appendix D) Ties, Cable, Plastic (Item 69, Appendix D) Insulation Sleeving, Electrical (Item 29, Appendix D) Nut, Conduit (Item 123, Appendix G)
Tools and Special Tools Tool Kit, Genl Mech (Item 46, Appendix C) Tool Kit, Electrical (Item 45, Appendix C)	

a. Disassembly.

- (1) Open cover (1) on REMOTE CONTROL (2).
- (2) Remove four screws (3), washers (4), and panel (5) from REMOTE CONTROL (2).

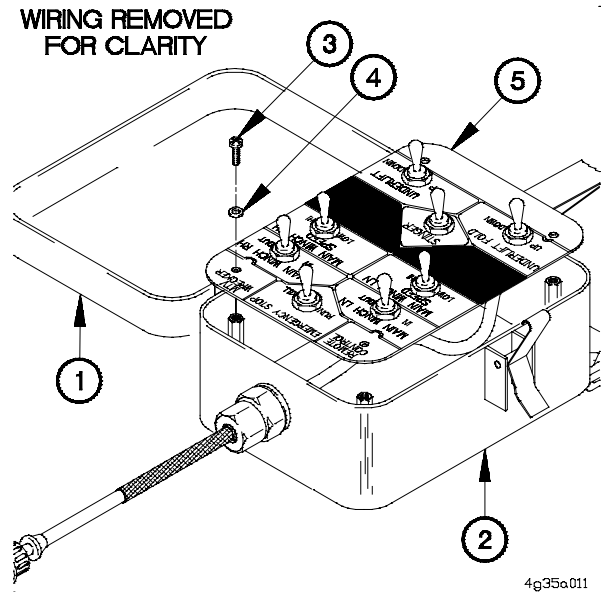

7-35. M1089 WRECKER REMOTE CONTROL REPAIR (CONT)

NOTE

- Remove plastic cable ties as required.
- All 8 switches are removed the same way. UNDERLIFT FOLD switch shown.

(3) Remove switch cover nut (6) and switch (7) from panel (5).

NOTE

- Cut cable wires at heat shrink when removing switch.
- Tag wires and connection points prior to disconnecting.

(4) Remove switch (7) from cable (8).

(5) Perform steps (3) and (4) on remaining seven switches.

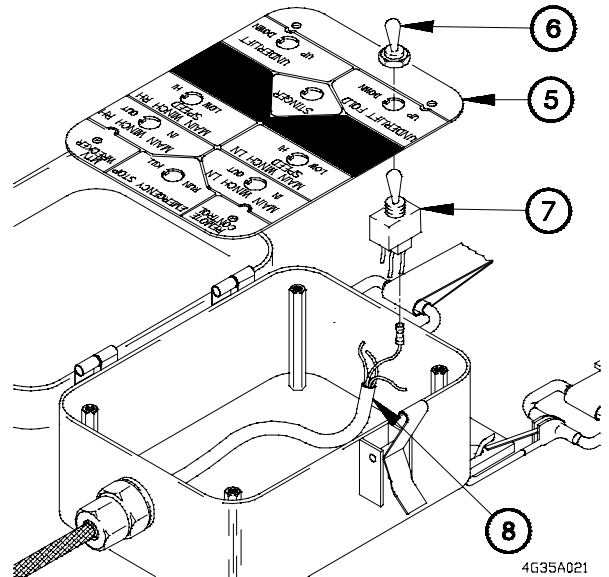

4G35A021

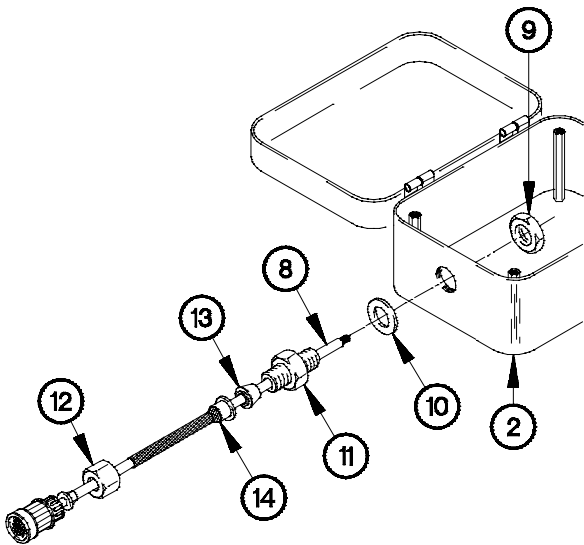

4g35e031

- (6) Remove conduit nut (9) and cable (8) from remote control box (2). Discard conduit nut.
- (7) Remove seal (10) from adapter (11).
- (8) Remove nut (12) from adapter (11).
- (9) Remove adapter (11), seal (13), grip (14), and nut (12) from cable (8).

b. Assembly.

- (1) Position nut (1), grip (2), seal (3), and adapter (4) on cable (5).
- (2) Install seal (6) on adapter (4).
- (3) Position cable (5) in remote control box (7).
- (4) Position conduit nut (8) on cable (5).

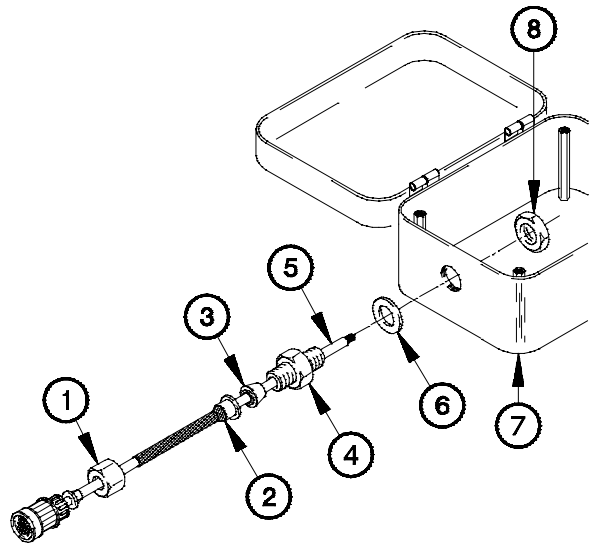

4g35b011

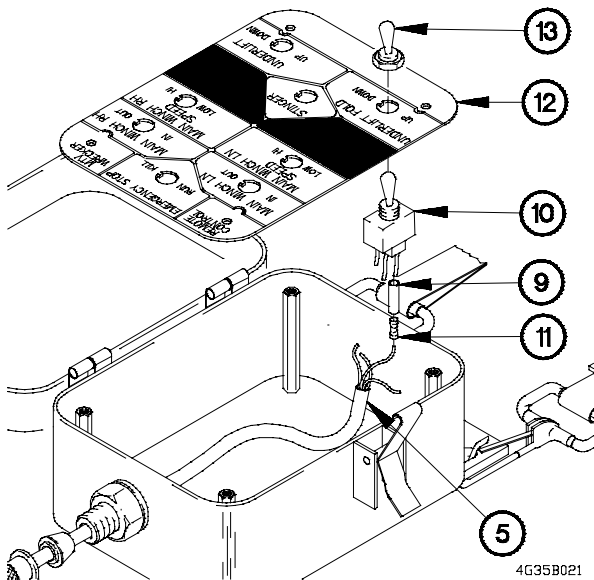

4G35B021

NOTE

Perform steps (5) through (7) for all switches.

- (5) Position tubing (9) on switch (10).
- (6) Attach switch (10) to cable (5) with splice connector (11).
- (7) Shrink tubing (9) over splice connector (11).
- (8) Install switch (10) in panel (12) with switch cover nut (13).

7-35. M1089 WRECKER REMOTE CONTROL REPAIR (CONT)

- (9) Install adapter (4) in REMOTE CONTROL (7) with conduit nut (8).
- (10) Install seal (3) and grip (2) on adapter (4) with nut (1).
- (11) Install panel (12) on REMOTE CONTROL (7) with four washers (14) and screws (15).
- (12) Close cover (16) on REMOTE CONTROL (7).

c. Follow-On Maintenance.

- Test operate wrecker with REMOTE CONTROL (TM 9-2320-366-10-1).

End of Task.

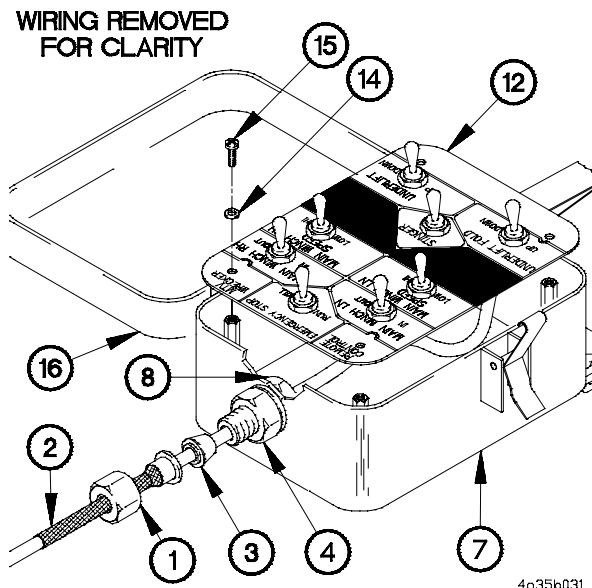

7-36. BACKUP LIGHT ASSEMBLY REPLACEMENT/REPAIR

This task covers:

- | | |
|--|--|
| <ul style="list-style-type: none"> a. M1088 Backup Light Assembly Removal b. M1088 Backup Light Assembly Installation c. M1089 Backup Light Assembly Removal d. M1089 Backup Light Assembly Installation e. Deleted f. Deleted | <ul style="list-style-type: none"> g. M1083/M1084/M1085/M1086/M1090/M1092/M1093/M1094/M1096 Backup Light Assembly Removal h. M1083/M1084/M1085/M1086/M1090/M1092/M1093/M1094/M1096 Backup Light Assembly Installation i. Disassembly j. Assembly k. Follow-On Maintenance |
|--|--|

INITIAL SETUP

Equipment Conditions

Batteries disconnected (para 7-57).

Tools and Special Tools

Tool Kit, Genl Mech (Item 46, Appendix C)
Wrench, Torque, 0-175 lb-ft (Item 58, Appendix C)

Materials/Parts

Lockwasher (2) (Item 96, Appendix G)
Lockwasher (4) (Item 114, Appendix G)
Packing, Preformed (Item 215, Appendix G)
Nut, Self-Locking (4) (Item 168, Appendix G)

a. M1088 Backup Light Assembly Removal.

- (1) Disconnect backup light connector (1) from connector P87 (2).
- (2) Remove two screws (3), lockwashers (4), terminal lug TL17 (5), and backup light assembly (6) from bracket (7). Discard lockwashers.

b. M1088 Backup Light Assembly Installation.

- (1) Position terminal lug TL17 (5), two lockwashers (4), screws (3), and backup light assembly (6) on bracket (7).
- (2) Tighten two screws (3) to 19-24 lb-ft (26-32 N-m).
- (3) Connect connector P87 (2) to backup light connector (1).

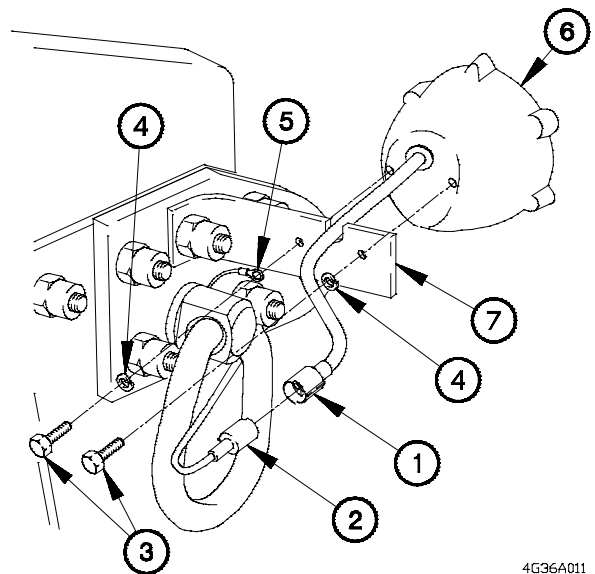

4G36A011

7-36. BACKUP LIGHT ASSEMBLY REPLACEMENT/REPAIR (CONT)

c. M1089 Backup Light Assembly Removal.

- (1) Disconnect backup light connector (1) from connector P87 (2).
- (2) Remove screw (3), lockwasher (4), and terminal lug TL47 (5) from bracket (6). Discard lockwasher.
- (3) Remove screw (7), lockwasher (8), and backup light assembly (9) from bracket (6). Discard lockwasher.

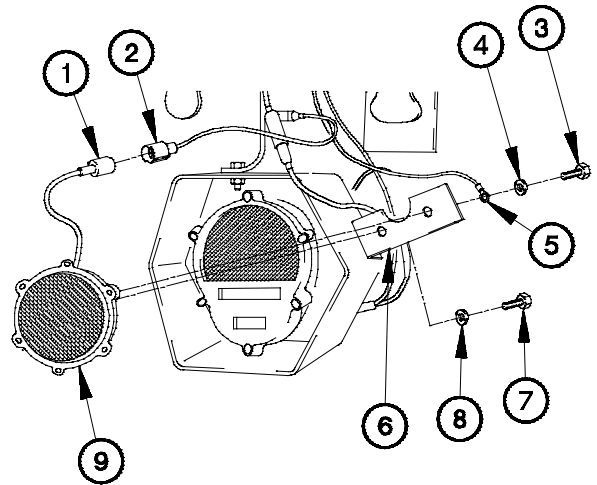

4G36C011

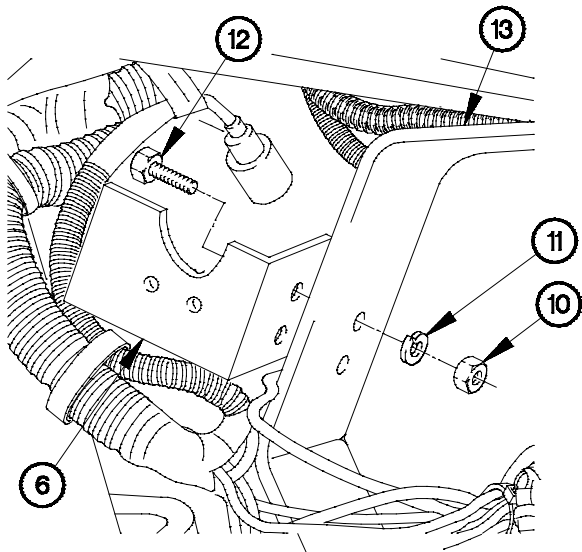

4G36C021

- (4) Remove two self-locking nuts (10), lockwashers (11), screws (12), and bracket (6) from bracket (13). Discard lockwashers and self-locking nuts.

d. M1089 Backup Light Assembly Installation.

- (1) Position bracket (1) on bracket (2) with two lockwashers (3), screws (4), and self-locking nuts (5).
- (2) Tighten two screws (4) to 35-43 lb-ft (48-58 N·m).

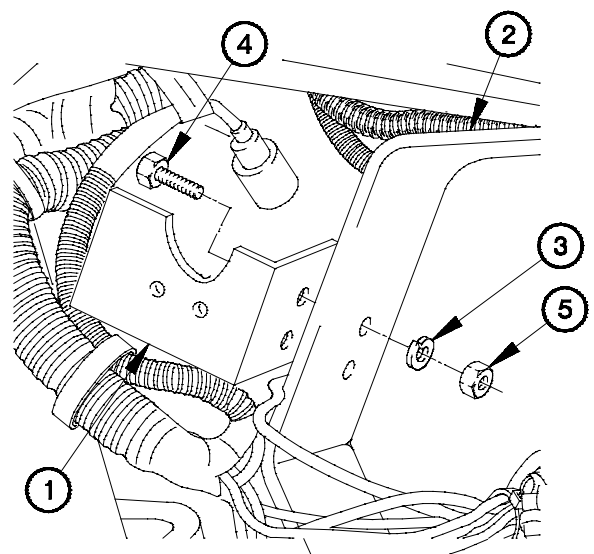

4G36D011

- (3) Position backup light assembly (6) on bracket (1) with lockwasher (7) and screw (8).
- (4) Position terminal lug TL47 (9), lockwasher (10), and screw (11) in backup light assembly (6).
- (5) Tighten screws (8 and 11) to 35-42 lb-ft (48-57 N·m).
- (6) Connect backup light connector (12) to connector P87 (13).

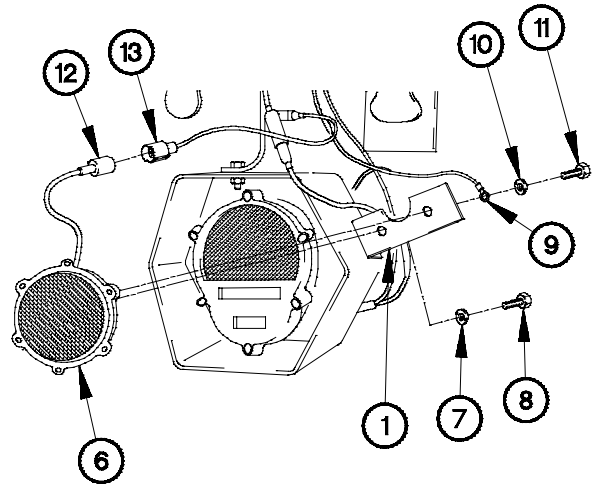

4G36D021

e. Deleted

7-36. BACKUP LIGHT ASSEMBLY REPLACEMENT/REPAIR (CONT)

f. Deleted

**g. M1083/M1084/M1085/M1086/M1090/M1092/M1093/
M1094/M1096/ Backup Light Assembly Removal.**

- (1) Disconnect backup light connector (1) from connector P87 (2).
- (2) Remove two screws (3), lockwashers (4), terminal lug TL17 (5), and backup light assembly (6) from taillight carrier (7). Discard lockwashers.

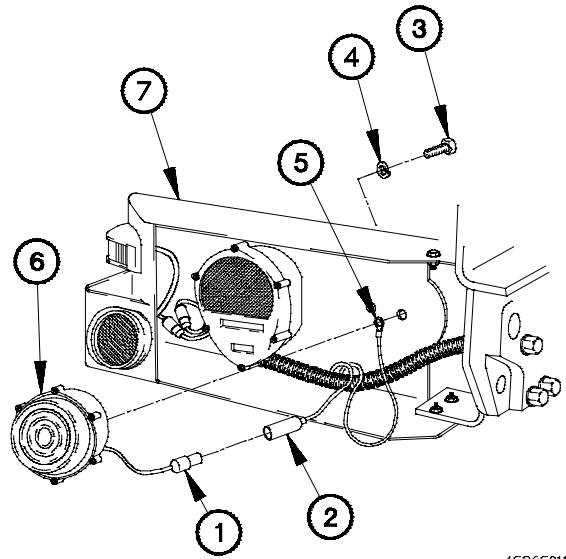

4G36G011

**h. M1083/M1084/M1085/M1086/M1090/M1092/M1093/
M1094/M1096 Backup Light Assembly Installation.**

- (1) Position terminal lug TL17 (5), two lockwashers (4), screws (3), and backup light assembly (6) on taillight carrier (7).
- (2) Tighten two screws (3) to 35-42 lb-ft (48-57 N-m).
- (3) Connect backup light connector (1) to connector P87 (2).

i. Disassembly.

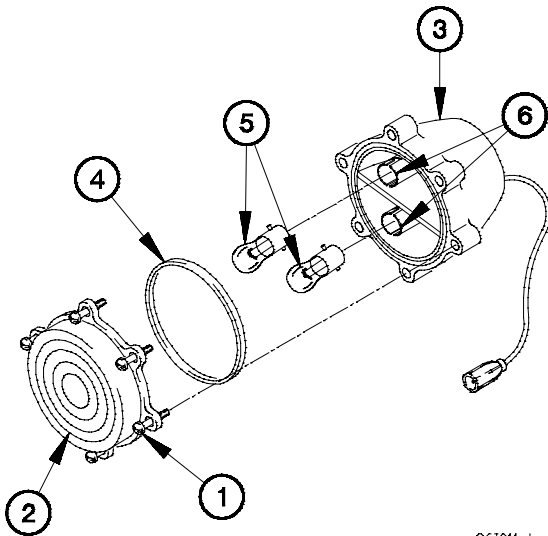

xq361011.dwg

- (1) Loosen six screws (1) on lens (2).
- (2) Remove lens (2) from housing (3).
- (3) Remove preformed packing (4) from housing (3). Discard preformed packing.
- (4) Remove two lamps (5) from sockets (6).

7-36. BACKUP LIGHT ASSEMBLY REPLACEMENT/REPAIR (CONT)

j. Assembly.

- (1) Install two lamps (1) in sockets (2).
- (2) Install preformed packing (3) and lens (4) on housing (5) with six screws (6).

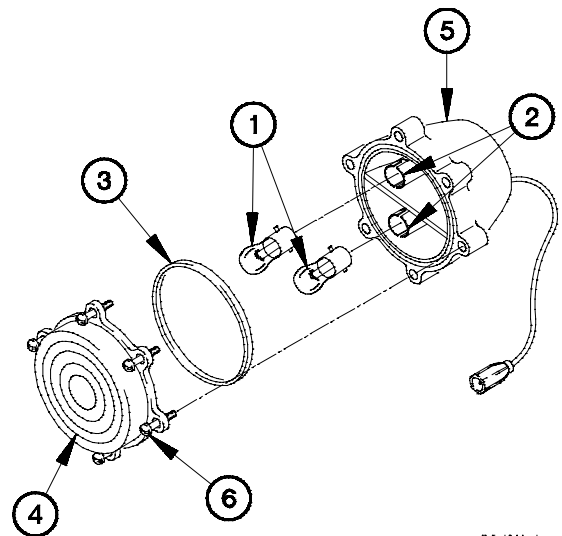

xa36J011.dwg

k. Follow-On Maintenance.

- (1) Connect batteries (para 7-57).
- (2) Check backup light operation (TM 9-2320-366-10-1).

End of Task.

7-37. BLACKOUT DRIVE LIGHT REPLACEMENT/REPAIR

This task covers:

- | | |
|----------------|--------------------------|
| a. Removal | d. Installation |
| b. Disassembly | e. Follow-On Maintenance |
| c. Assembly | |

INITIAL SETUP

Equipment Conditions

Batteries disconnected (para 7-57).

Tools and Special Tools

Tool Kit, Genl Mech (Item 46, Appendix C)
 Wrench, Torque, 0-200 lb-in. (Item 59, Appendix C)
 Socket Set, Socket Wrench (Item 34, Appendix C)

Materials/Parts

Lockwasher (Item 96, Appendix G)
 Packing, Preformed (Item 189, Appendix G)

a. Removal.

- (1) Disconnect connector P17 (1) from blackout drive light (2).
- (2) Remove nut (3), lockwasher (4), washer (5), washer (6), and terminal lug TL79 (7) from blackout drive light (2). Discard lockwasher.
- (3) Remove blackout drive light (2) from bumper (8).

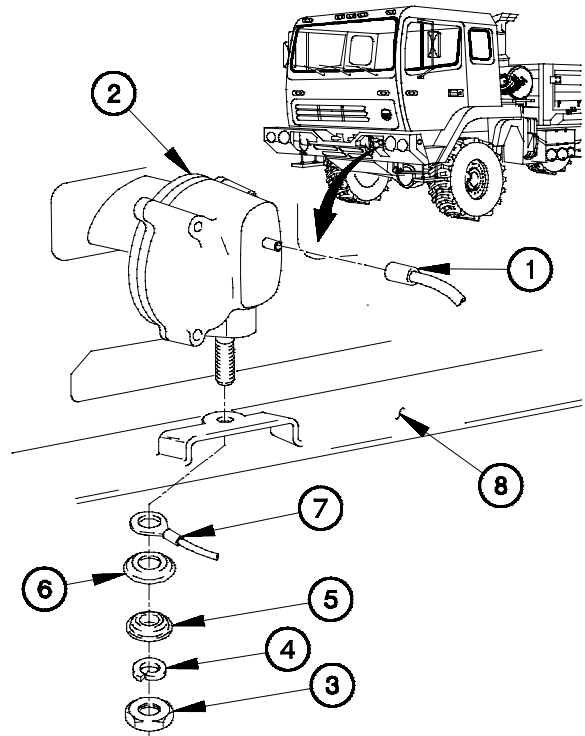

b. Disassembly.

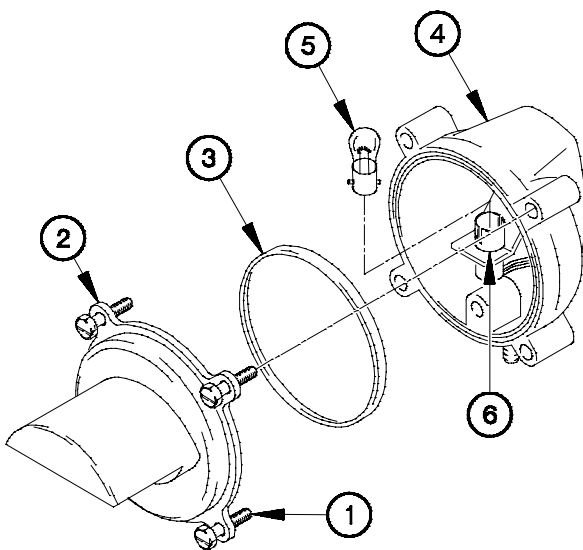

xa37B011.dwa

- (1) Loosen three screws (1) on cover (2).
- (2) Remove cover (2) and preformed packing (3) from housing (4). Discard preformed packing.
- (3) Remove lamp (5) from socket (6).

xa37A011.dwa

7-37. BLACKOUT DRIVE LIGHT REPLACEMENT/REPAIR (CONT)

c. Assembly.

- (1) Install lamp (1) in socket (2).
- (2) Install preformed packing (3) and cover (4) on housing (5) with three screws (6).

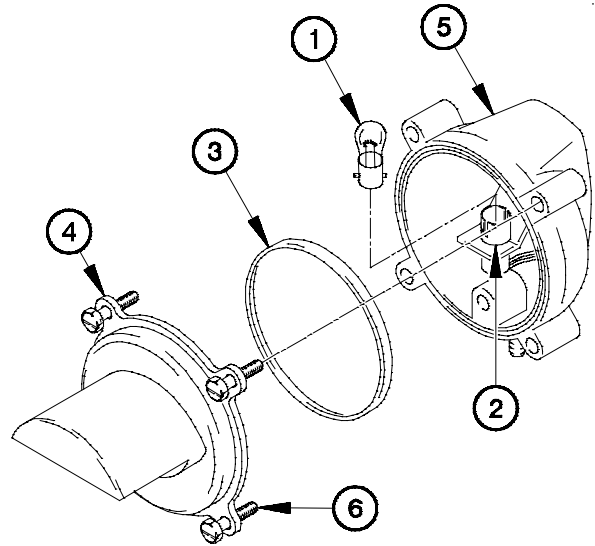

xa37C011.dwg

d. Installation.

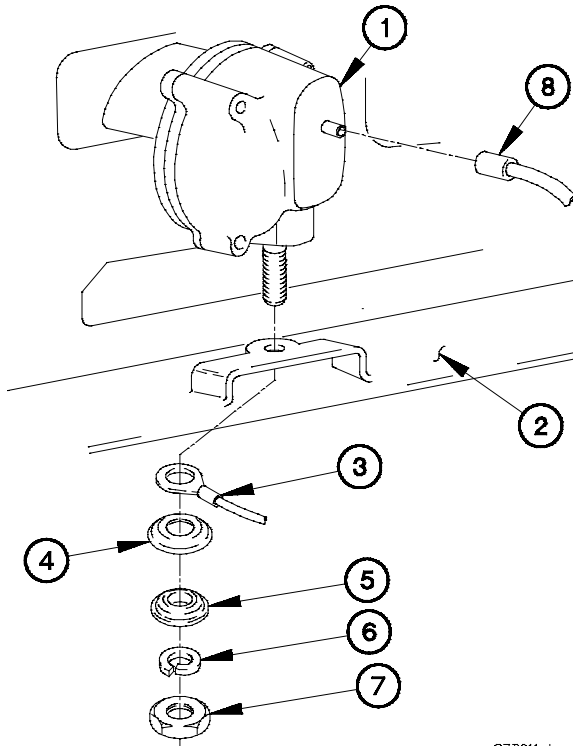

xa37D011.dwg

- (1) Position blackout drive light (1) on bumper (2).
- (2) Position terminal lug TL79 (3), washer (4), washer (5), lockwasher (6), and nut (7) on blackout drive light (1).
- (3) Tighten nut (7) to 156-192 lb-in. (18-22 N-m).
- (4) Connect connector P17 (8) to back of blackout drive light (1).

e. Follow-On Maintenance.

- (1) Connect batteries (para 7-57).
- (2) Check blackout drive light operation (TM 9-2320-366-10-1).

End of Task.

7-38. CLEARANCE AND MARKER LIGHT ASSEMBLIES REPLACEMENT

This task covers:

- a. Cab Clearance and Marker Light Removal
- b. Cab Clearance and Marker Light Installation
- c. Chassis Clearance and Marker Light Removal
- d. Chassis Clearance and Marker Light Installation
- e. Follow-On Maintenance

INITIAL SETUP

Equipment Conditions

Batteries disconnected (para 7-57).

Tools and Special Tools

Tool Kit, Genl Mech (Item 46, Appendix C)

Materials/Parts

Adhesive (Item 5, Appendix D)

Lockwasher (2) (Item 82, Appendix G)

a. Cab Clearance and Marker Light Removal.

NOTE

All cab clearance and marker lights are removed the same way. Front left marker light shown.

- (1) Remove two screws (1) and lens cover (2) from base (3).
- (2) Remove two clips (4) and lens (5) from lens cover (2).

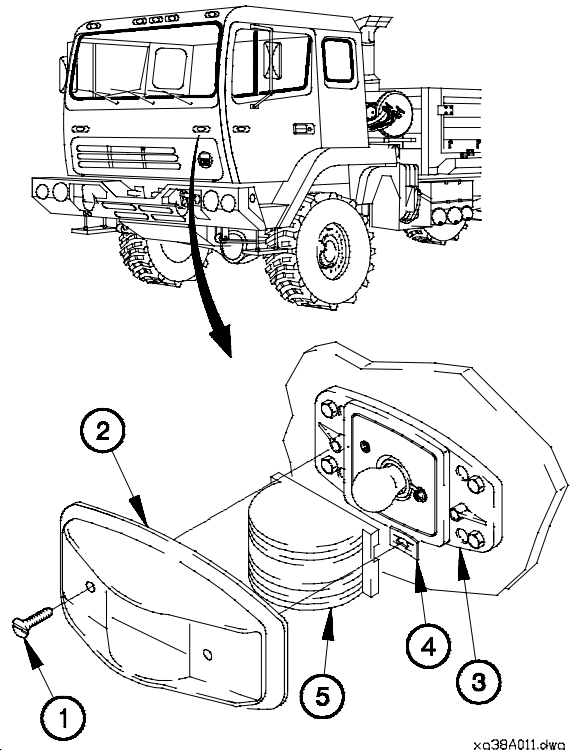

xa38A011.dwa

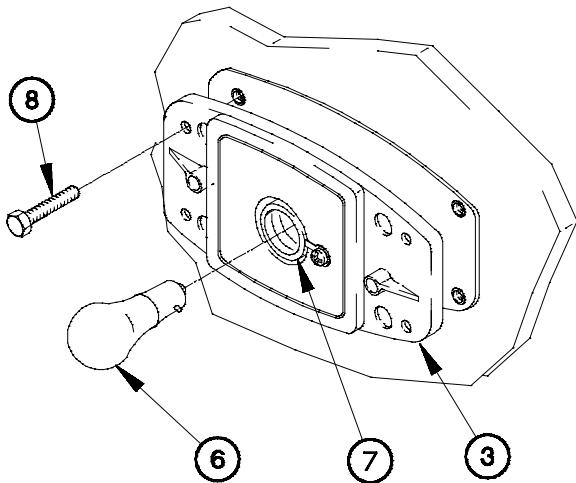

xa38A021.dwa

- (3) Remove lamp (6) from socket (7).
- (4) Remove four screws (8) from base (3).

7-38. CLEARANCE AND MARKER LIGHT ASSEMBLIES REPLACEMENT (CONT)

CAUTION

Do not let wires slip through hole and into cab structure. If wires slip into cab structure, vehicle will need further disassembly to retrieve wires.

- (5) Disconnect marker light connector (9) from connector P50 (10).
- (6) Remove nut (11), lockwasher (12), terminal lug (13), lockwasher (14), base (3), and gasket (15) from vehicle. Discard lockwashers.
- (7) Remove nut (16), and screw (17) from base (3).

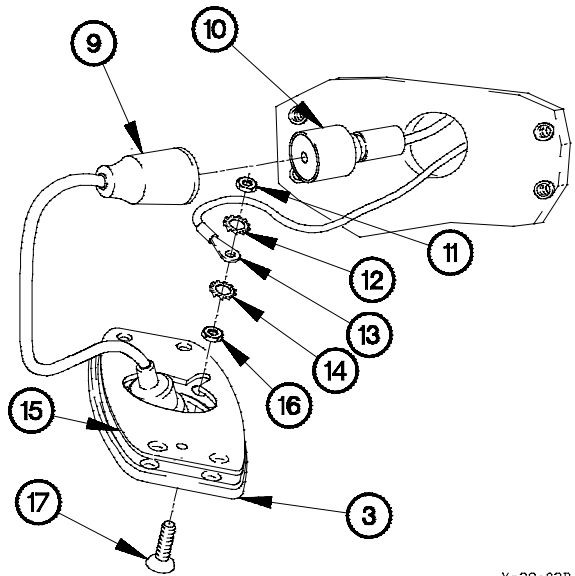

Xg38a03B

b. Cab Clearance and Marker Light Installation.

WARNING

Adhesives, solvents, and sealing compounds can burn easily, can give off harmful vapors, and are harmful to skin and clothing. Keep away from open fire and use in a well-ventilated area. If adhesive, solvent, or sealing compound gets on skin or clothing, wash immediately with soap and water. Failure to comply may result in injury to personnel.

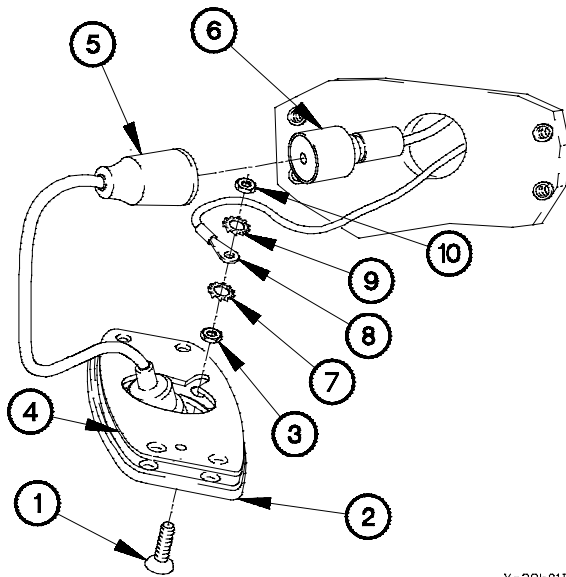

Xg38b01B

- (1) Apply adhesive to threads of screw (1).
- (2) Install screw (1) in base (2) with nut (3).

NOTE

Clearance and marker lights originally come with cork gaskets. Discard cork gaskets and replace with rubber gaskets PN 12421469.

- (3) Install gasket (4) on base (2).
- (4) Connect marker light connector (5) to connector P50 (6).
- (5) Install lockwasher (7), terminal lug (8), lockwasher (9), and nut (10) on back of base (2).

- (6) Install base (2) on vehicle with four screws (11).
- (7) Install lamp (12) in socket (13).

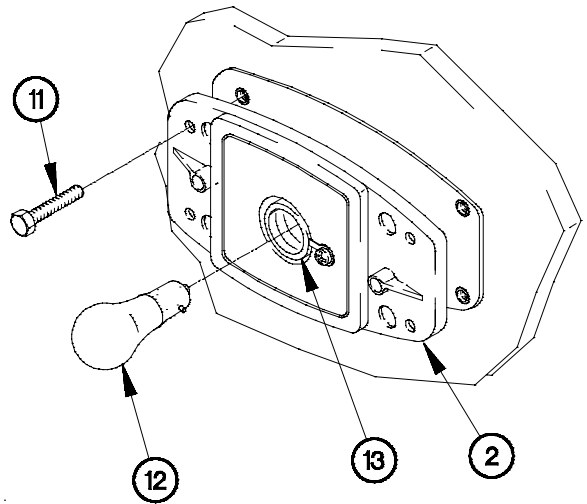

xq38B021.dwg

- (8) Install lens (14) in lens cover (15) with two clips (16).
- (9) Install lens cover (15) on base (2) with two screws (17).

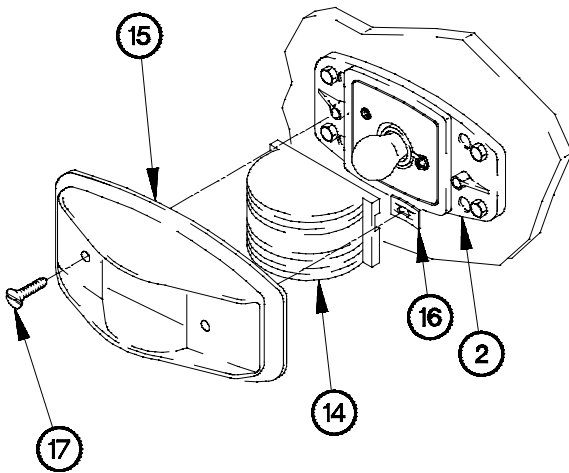

XG38B031

c. Chassis Clearance and Marker Light Removal.

NOTE

All chassis clearance and marker lights are removed the same way. Right rear marker light shown.

- (1) Remove two screws (1) and lens cover (2) from base (3).
- (2) Remove two clips (4) and lens (5) from lens cover (2).

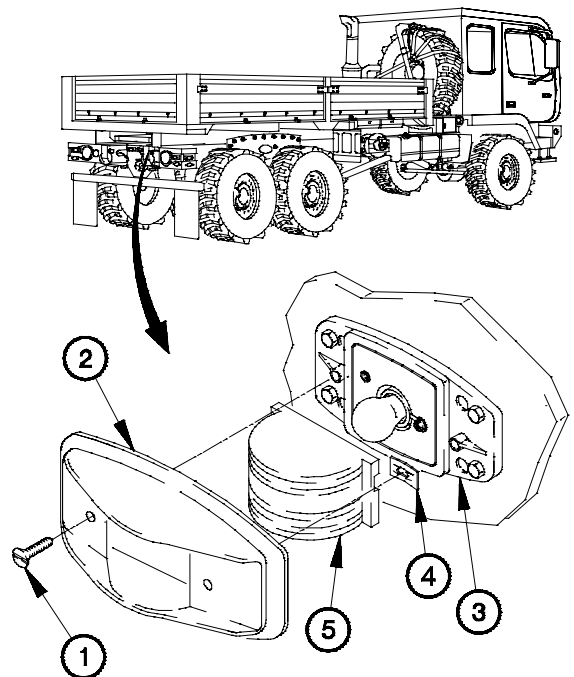

4G38C011

7-38. CLEARANCE AND MARKER LIGHT ASSEMBLIES REPLACEMENT (CONT)

(3) Remove lamp (6) from socket (7).

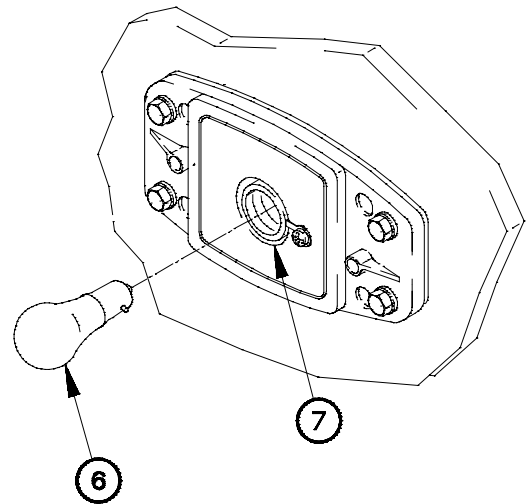

XG38C021

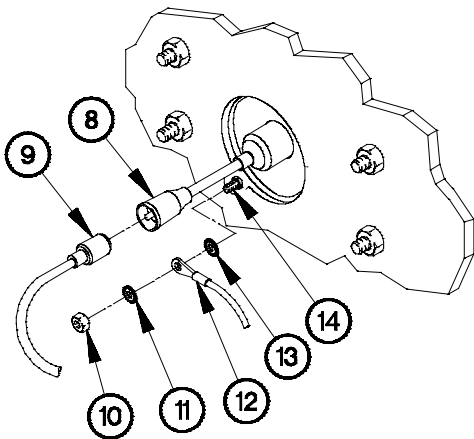

XG38C03B

(4) Disconnect marker light connector (8) from connector P54 (9).

(5) Remove nut (10), lockwasher (11), terminal lug (12), and lockwasher (13) from screw (14). Discard lockwashers.

NOTE

Perform step (6) on three center clearance lights on all models except M1084/M1086 and M1089.

(6) Remove four nuts (15), washers (16), screws (17), washers (18), base (3), and gasket (19) from vehicle.

NOTE

Perform step (7) on three center clearance lights on M1084/M1086 and M1089.

(7) Remove four nuts (15), washers (16), screws (17), base (3), and gasket (19) from vehicle.

(8) Remove nut (20) and screw (14) from base (3).

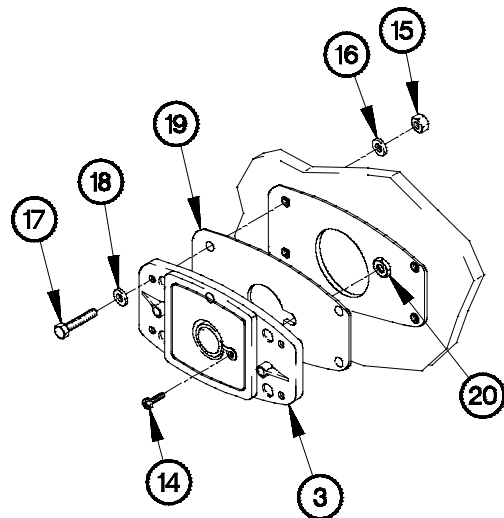

XG38C04B

d. Chassis Clearance and Marker Light Installation.

WARNING

Adhesives, solvents, and sealing compounds can burn easily, can give off harmful vapors, and are harmful to skin and clothing. Keep away from open fire and use in a well-ventilated area. If adhesive, solvent, or sealing compound gets on skin or clothing, wash immediately with soap and water. Failure to comply may result in injury to personnel.

- (1) Apply adhesive to threads of screw (1).
- (2) Install screw (1) in base (2) with nut (3).

NOTE

Clearance and marker lights originally come with cork gaskets. Discard cork gaskets and replace with rubber gaskets PN 12421469.

(3) DELETED

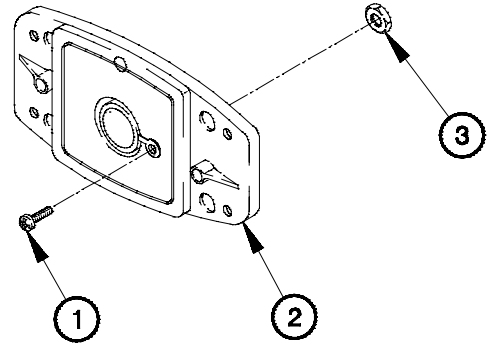

4G38D01B

NOTE

Perform step (4) on three center clearance lights on M1084/M1086 and M1089.

- (4) Install gasket (4) and base (2) on vehicle with four screws (5), washers (6), and nuts (7).

NOTE

Perform step (5) on three center clearance lights on all models except M1084/M1086 and M1089.

- (5) Install gasket (4) and base (2) on vehicle with four washers (8), screws (5), washers (6), and nuts (7).

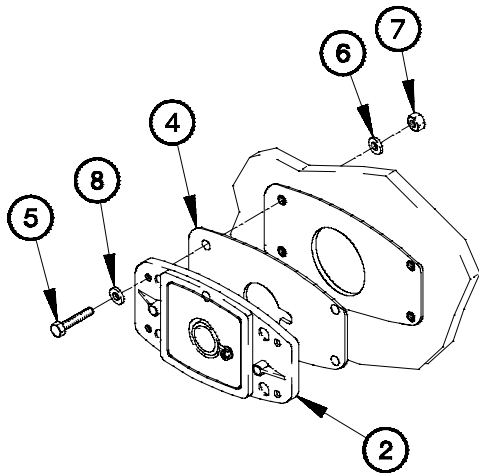

4G38D02B

7-38. CLEARANCE AND MARKER LIGHT ASSEMBLIES REPLACEMENT (CONT)

- (6) Install lockwasher (9) and terminal lug (10) on screw (1) with lockwasher (11) and nut (12).
- (7) Connect marker light connector (13) to connector P54 (14).

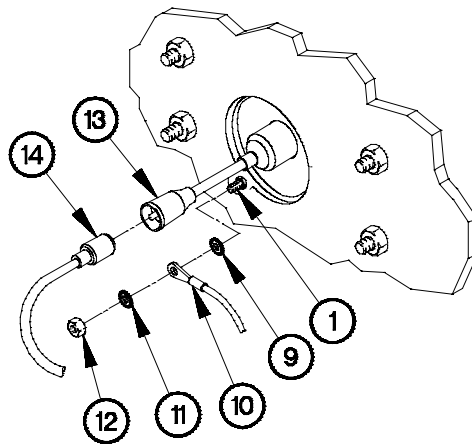

4G38D03B

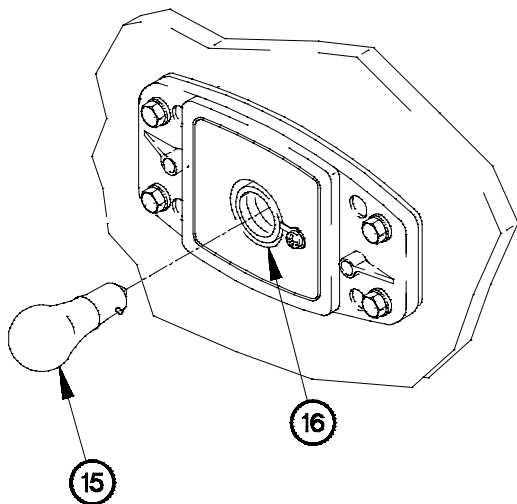

Xg38a04b

- (8) Install lamp (15) in socket (16).

- (9) Install lens (17) on lens cover (18) with two clips (19).
- (10) Install lens cover (18) on base (2) with two screws (20).

e. Follow-On Maintenance.

- (1) Connect batteries (para 7-57).
- (2) Check clearance and marker light operation (TM 9-2320-366-10-1).

End of Task.

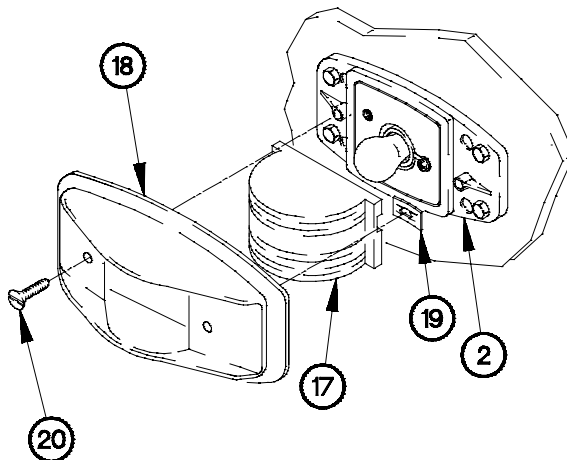

Xg38a05B

7-39. COMPOSITE TAILLIGHT ASSEMBLY REPLACEMENT/REPAIR

This task covers:

- | | |
|--|--|
| <ul style="list-style-type: none"> a. M1088 Composite Taillight Assembly Removal b. M1088 Composite Taillight Assembly Installation c. M1089 Composite Taillight Assembly Removal d. M1089 Composite Taillight Assembly Installation e. Deleted f. Deleted g. Deleted | <ul style="list-style-type: none"> h. Deleted i. Composite Taillight Assembly Removal (All Models Except M1088/M1089) j. Composite Taillight Assembly Installation (All Models Except M1088/M1089) k. Disassembly l. Assembly m. Follow-On Maintenance |
|--|--|

INITIAL SETUP

Equipment Conditions

Batteries disconnected (para 7-57).

Tools and Special Tools

Tool Kit, Genl Mech (Item 46, Appendix C)
 Wrench, Torque, 0-175 lb-ft (Item 58, Appendix C)
 Wrench, Torque, 0-200 lb-in. (Item 59, Appendix C)
 Wrench Set, Socket (Item 51, Appendix C)

Materials/Parts

Dispenser, Pressure Sensitive Adhesive Tape (Item 20, Appendix D)
 Ties, Cable, Plastic (Item 69, Appendix D)
 Lockwasher (2) (Item 96, Appendix G)
 Packing, Preformed (Item 191, Appendix G)

NOTE

- Tag wires and connection points prior to disconnecting.
- Remove plastic cable ties as required.
- Right side connectors are P61, P62, P63, P64, 22-460, 24, 23, 21, and TL 21.

a. M1088 Composite Taillight Assembly Removal.

NOTE

Left and right composite taillights are removed the same way. Left side shown.

- (1) Disconnect connectors P74, P76, P77, P78 (1) from composite taillight connectors 22-461, 24, 23, 21 (2).
- (2) Remove two screws (3), lockwashers (4), terminal lug TL18 (5), and composite taillight assembly (6) from vehicle. Discard lockwashers.

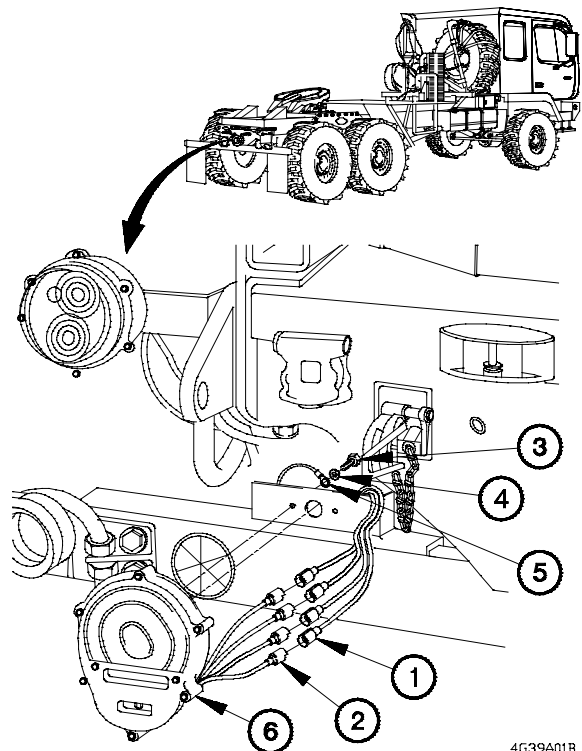

4G39A01B

7-39. COMPOSITE TAILLIGHT ASSEMBLY REPLACEMENT/REPAIR (CONT)

b. M1088 Composite Taillight Assembly Installation.

NOTE

- Left and right composite taillights are installed the same way. Left side shown.
- Install plastic cable ties as required.

- (1) Position composite taillight assembly (1) on vehicle with terminal lug TL18 (2), two lockwashers (3), and screws (4).
- (2) Tighten two screws (4) to 19-24 lb-ft (26-32 N-m).
- (3) Connect connectors P74, P76, P77, P78 (5) to composite taillight connectors 22-461, 24, 23, 21 (6).

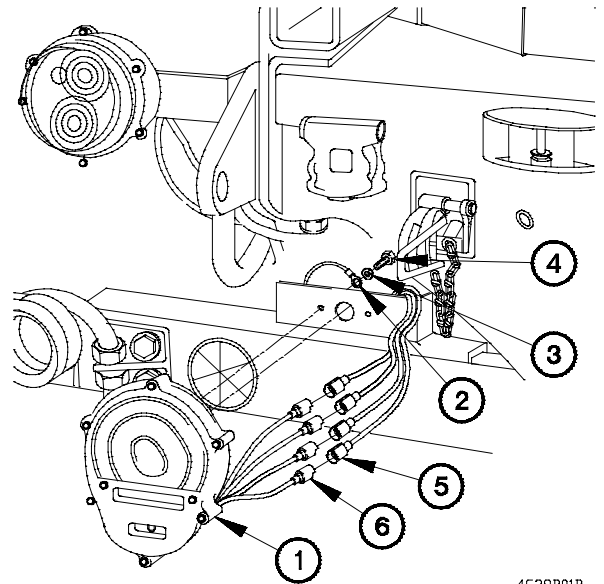

4G39B01B

c. M1089 Composite Taillight Assembly Removal.

NOTE

Left and right composite taillights are removed the same way. Left side shown.

- (1) Disconnect connectors P74, P76, P77, P78 (1) from composite taillight connectors 22-461, 24, 23, 21 (2).
- (2) Remove two screws (3), lockwashers (4), terminal lugs TL18 (5), and composite taillight assembly (6) from vehicle. Discard lockwashers.

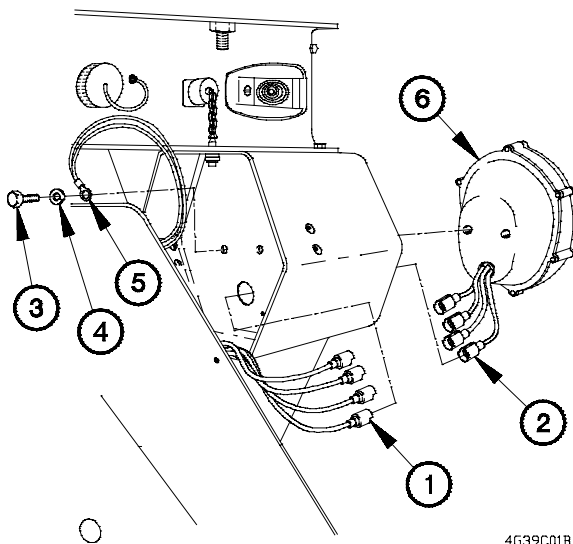

4G39C01B

d. M1089 Composite Taillight Assembly Installation.**NOTE**

- Left and right composite taillights are installed the same way. Left side shown.
- Install plastic cable ties as required.

- (1) Position composite taillight assembly (1) on vehicle with two terminal lugs TL18 (2), lockwashers (3), and screws (4).
- (2) Tighten two screws (4) to 50-60 lb-in. (6-7 N·m).
- (3) Connect connectors P74, P76, P77, P78 (5) to composite taillight connectors 22-461, 24, 23, 21 (6).

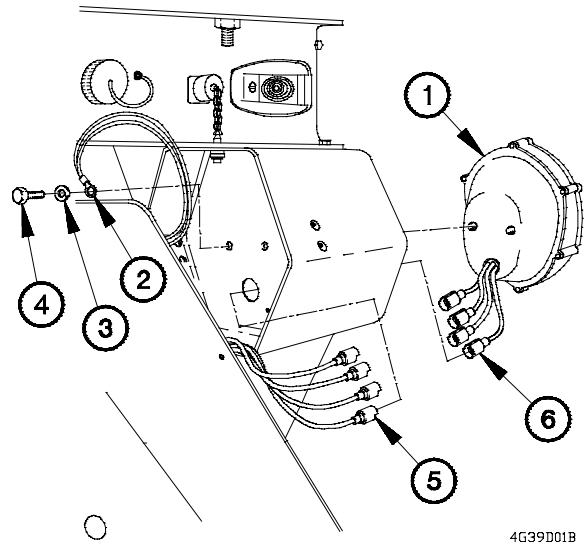

4G39D01B

e. Deleted.

7-39. COMPOSITE TAILLIGHT ASSEMBLY REPLACEMENT/REPAIR (CONT)

f. Deleted.

g. Deleted.

h. Deleted.

i. Composite Taillight Assembly Removal (All Models Except M1088/M1089).

NOTE

Left and right composite taillights are removed the same way. Left side shown.

- (1) Remove self-locking nut (1), screw (2), and clamp (3) from taillight carrier (4). Discard self-locking nut.
- (2) Disconnect connectors P74, P76, P77, P78 (5) from composite taillight connectors 22-461, 24, 23, 21 (6).
- (3) Remove two screws (7), lockwashers (8), terminal lug TL18 (9), and composite taillight assembly (10) from taillight carrier (4). Discard lockwashers.

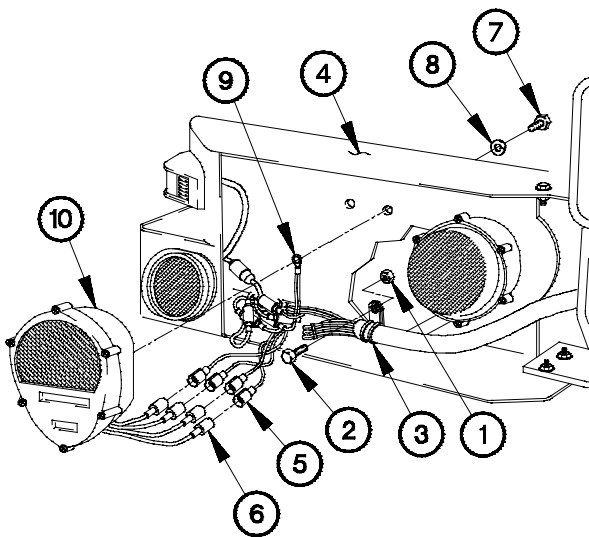

4G39101B

7-39. COMPOSITE TAILLIGHT ASSEMBLY REPLACEMENT/REPAIR (CONT)

j. Composite Taillight Assembly Installation (All Models Except M1088/M1089).

NOTE

- Left and right composite taillights are installed the same way. Left side shown.
- Install plastic cable ties as required.

- (1) Position two lockwashers (1), screws (2), terminal lug TL18 (3), and composite taillight assembly (4) on taillight carrier (5).
- (2) Tighten two screws (2) to 35-42 lb-ft (48-57 N-m).
- (3) Connect connectors P74, P76, P77, P78 (6) to composite taillight connectors 22-461, 24, 23, 21 (7).
- (4) Install clamp (8) on taillight carrier (5) with screw (9) and self-locking nut (10).

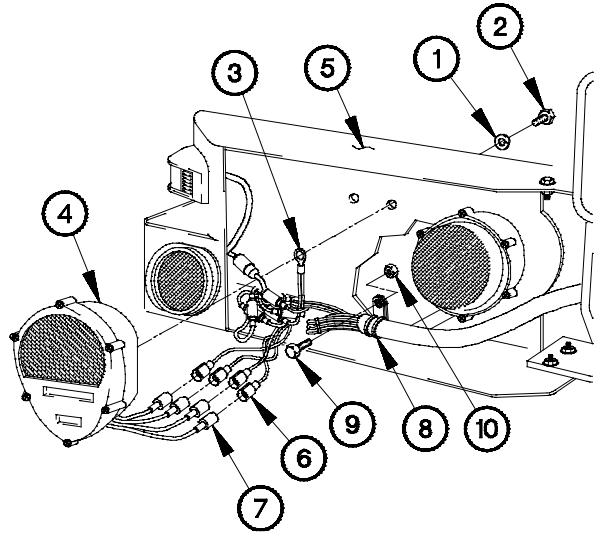

4G39J01B

k. Disassembly.

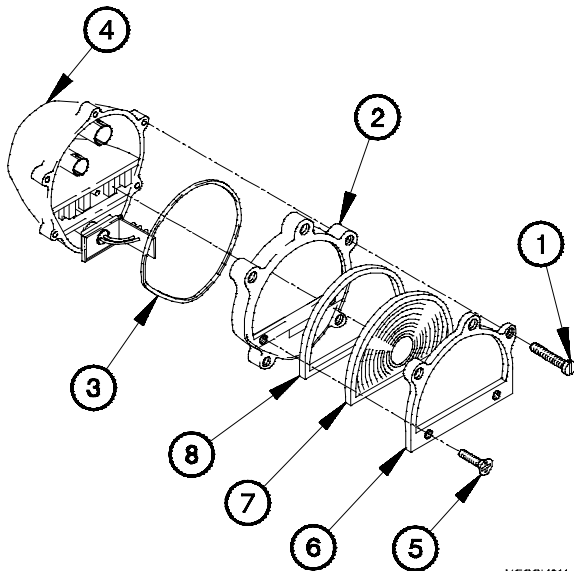

XG39K011

- (1) Remove six screws (1), cover (2), and preformed packing (3) from housing (4). Discard preformed packing.
- (2) Remove two screws (5), bezel (6), lens (7), and retainer (8) from cover (2).

- (3) Remove lamps (9 and 10) from sockets (11 and 12).
- (4) Position blackout stoplight lamp (13) for access to socket (14).
- (5) Remove connector (15) from socket (14).
- (6) Position blackout marker lamp (16) for access to socket (17).
- (7) Remove connector (18) from socket (17).

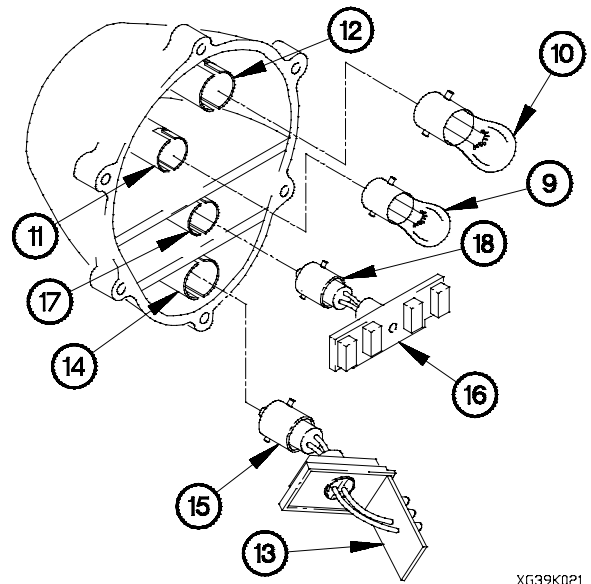

XG39K021

I. Assembly.

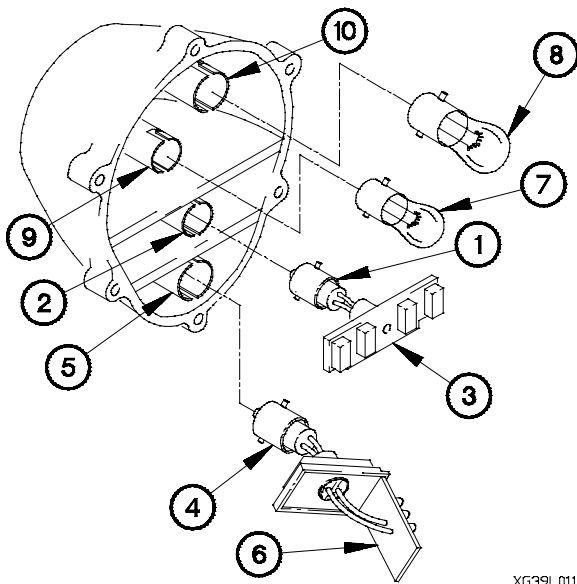

XG39L011

- (1) Install connector (1) in socket (2).
- (2) Position blackout marker lamp (3) in connector (1).
- (3) Install connector (4) in socket (5).
- (4) Install blackout stoplight lamp (6) in connector (4).
- (5) Install two lamps (7 and 8) in sockets (9 and 10).

- (6) Position retainer (11), lens (12), and bezel (13) on cover (14) with two screws (15).
- (7) Position preformed packing (16) and cover (14) on housing (17) with six screws (18).
- (8) Tighten two screws (15) and six screws (18) to 20-25 lb-in. (1 N·m).

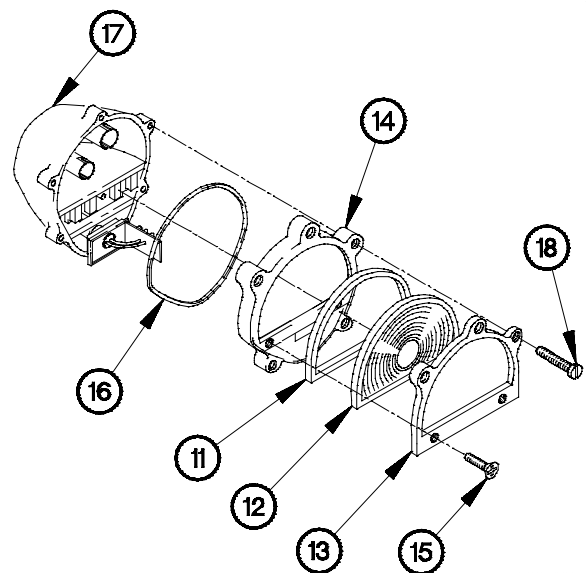

XG39L021

7-39. COMPOSITE TAILLIGHT ASSEMBLY REPLACEMENT/REPAIR (CONT)

m. Follow-On Maintenance.

- (1) Connect batteries (para 7-57).
- (2) Check operation of taillights (TM 9-2320-366-10-1).
- (3) Check operation of blackout lights (TM 9-2320-366-10-1).
- (4) Check operation of brake lights (TM 9-2320-366-10-1).

End of Task.

7-40. COMPOSITE FRONT LIGHT ASSEMBLY REPLACEMENT/REPAIR

This task covers:

- | | |
|----------------|--------------------------|
| a. Removal | d. Installation |
| b. Disassembly | e. Follow-On Maintenance |
| c. Assembly | |

INITIAL SETUP

Equipment Conditions

- Batteries disconnected (para 7-57).
- Cab raised (TM 9-2320-366-10-1).

Tools and Special Tools

- Tool Kit, Genl Mech (Item 46, Appendix C)
- Wrench, Torque, 0-200 lb-in. (Item 59, Appendix C)
- Socket Set, Socket Wrench (Item 34, Appendix C)

Materials/Parts

- Dispenser, Pressure Sensitive Adhesive Tape (Item 20, Appendix D)
- Lockwasher (2) (Item 96, Appendix G)
- Packing, Preformed (Item 191, Appendix G)

a. Removal.

NOTE

- Both composite front light assemblies are removed the same way. Left side shown.
- Tag wires and connection points prior to disconnecting.
- Connectors for right side are P8, P9 and P10.

- (1) Disconnect connectors P22, P23, and P24 (1) from composite front light assembly (2).
- (2) Remove two screws (3), lockwashers (4), three terminal lugs (5), and composite front light assembly (2) from front bumper (6). Discard lockwashers.

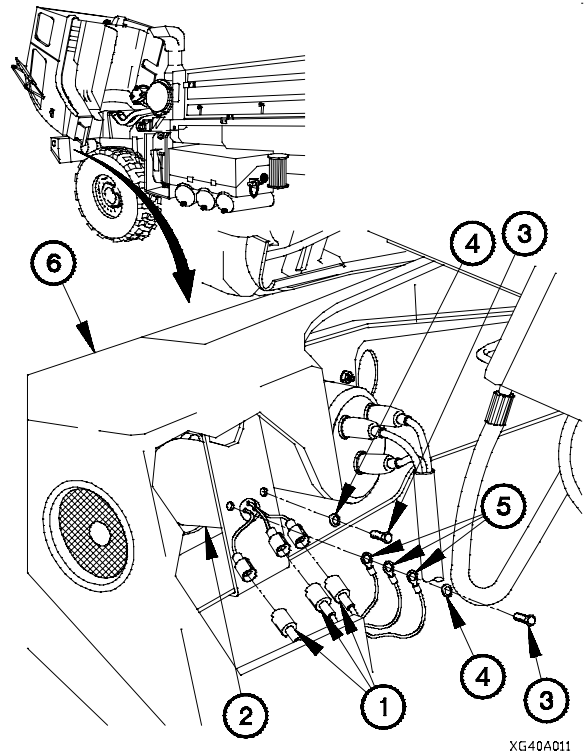

7-40. COMPOSITE FRONT LIGHT ASSEMBLY REPLACEMENT/REPAIR (CONT)

b. Disassembly.

- (1) Loosen five screws (1) on cover (2).
- (2) Remove cover (2) and preformed packing (3) from housing (4). Discard preformed packing.
- (3) Remove lamps (5 and 6) from sockets (7).
- (4) Open blackout marker lamp (8).
- (5) Remove blackout marker lamp (8) from socket (9).

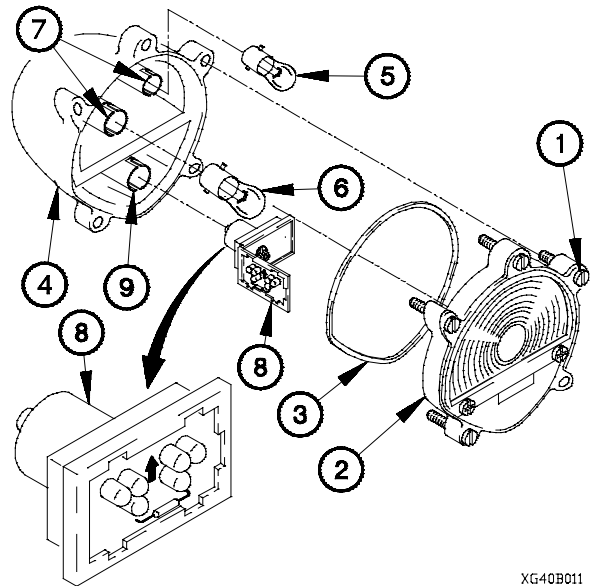

XG40B011

c. Assembly.

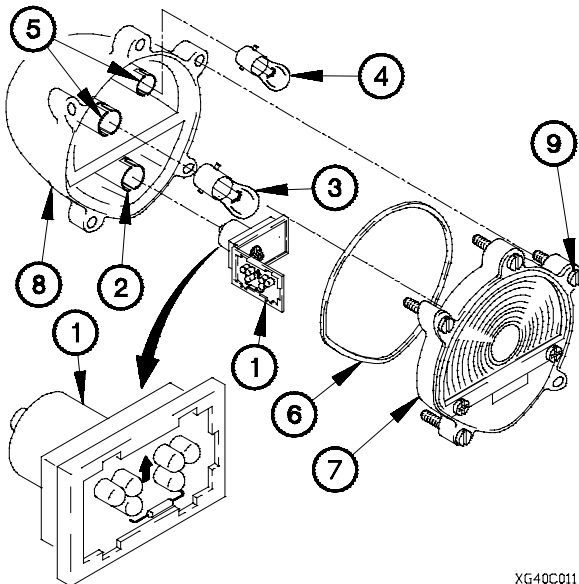

XG40C011

- (1) Open blackout marker lamp (1).
- (2) Install blackout marker lamp (1) in socket (2).
- (3) Install lamps (3 and 4) in sockets (5).
- (4) Install preformed packing (6) and cover (7) on housing (8) with five screws (9).

d. Installation.**NOTE**

Both composite front light assemblies are installed the same way. Left side shown.

- (1) Position composite front light assembly (1) in front bumper (2).
- (2) Position three terminal lugs (3), two lockwashers (4), and screws (5) on composite front light assembly (1).
- (3) Tighten two screws (5) to 156-192 lb-in. (18-22 N·m).
- (4) Connect connectors P22, P23, and P24 (6) to composite front light assembly (1).

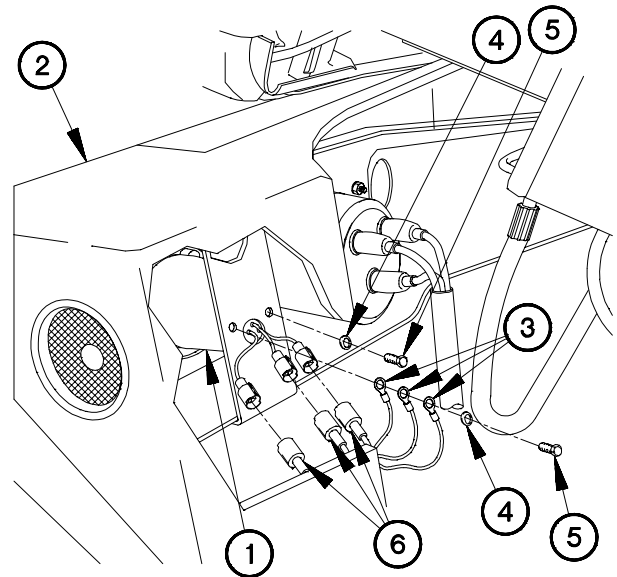

Xg40d011

e. Follow-On Maintenance.

- (1) Connect batteries (para 7-57).
- (2) Check operation of hazard lights, turn signals, park lights, and blackout marker lights (TM 9-2320-366-10-1).

End of Task.

7-41. HEADLIGHT AND HOUSING REPLACEMENT/REPAIR/ADJUSTMENT

This task covers:

a. Removal	d. Installation
b. Disassembly	e. Adjustment
c. Assembly	

INITIAL SETUP

<p>Equipment Conditions Batteries disconnected (para 7-57). Cab raised (TM 9-2320-366-10-1).</p> <p>Tools and Special Tools Tool Kit, Genl Mech (Item 46, Appendix C) Wrench, Torque, 0-200 lb-in. (Item 59, Appendix C) Socket Set, Socket Wrench (Item 34, Appendix C) Headlight Adjustment Screen (Item E-6, Appendix E)</p>	<p>Materials/Parts Dispenser, Pressure Sensitive Adhesive Tape (Item 18, Appendix C) Grommet, Nonmetallic (3) (Item 55, Appendix G) Lockwasher (3) (Item 85, Appendix G)</p>
---	--

a. Removal.

NOTE

- Both headlights are removed the same way. Left headlight shown.
- Perform steps (1) through (3) to remove lamp only.

(1) Remove three screws (1) and retaining ring (2) from housing (3).

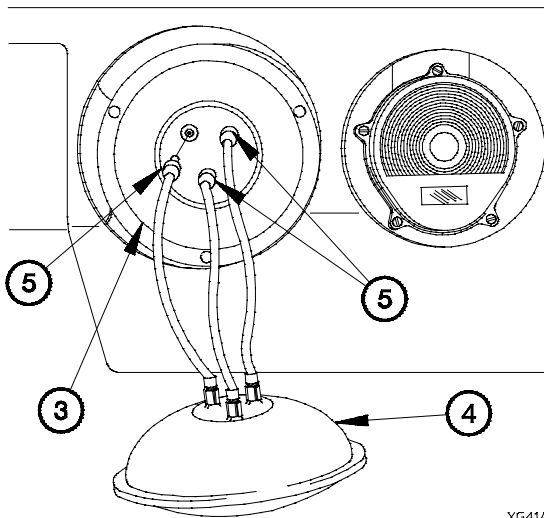
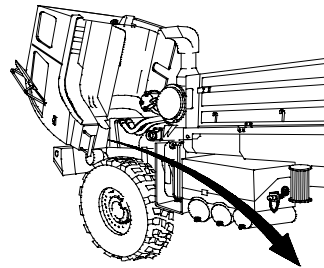

XG41A021

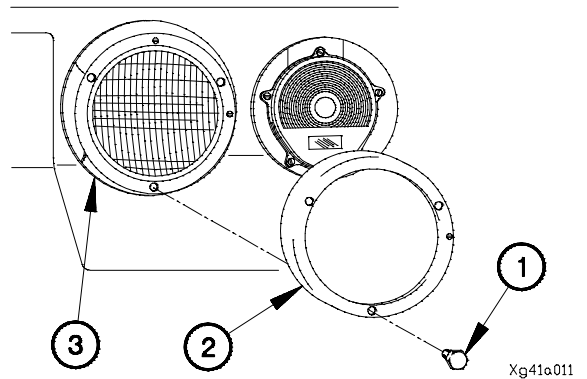

Xg41a011

(2) Remove lamp (4) from housing (3).

NOTE

- Tag connectors and connection points prior to disconnecting.
 - Connector numbers are the same on left and right headlights.
- (3) Disconnect connectors 18, 91, and 17 (5) from housing (3).

NOTE

- Tag connectors and connection points prior to disconnecting.
- Connectors for right side are P13, P14, and P12.

- (4) Disconnect connectors P4, P19, and P20 (6) from housing (3).
- (5) Remove three nuts (7) and housing (3) from bumper (8).

b. Disassembly.

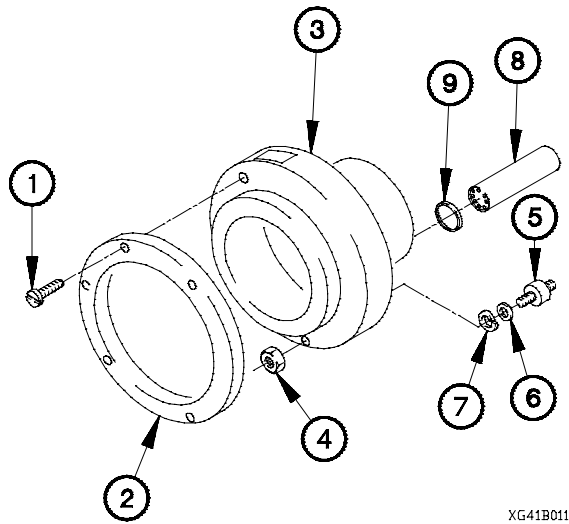
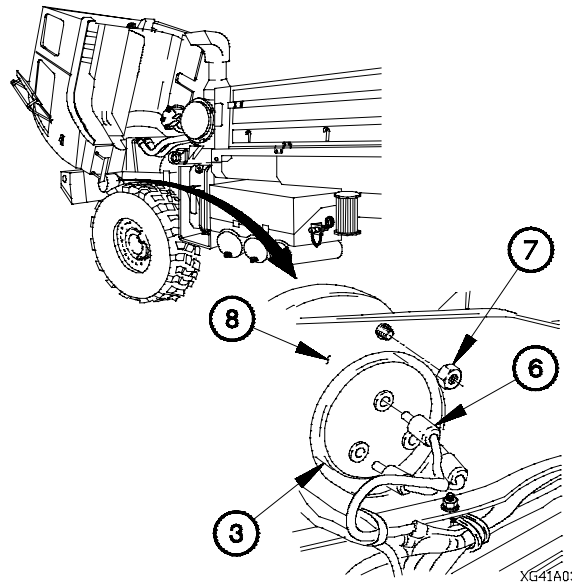

- (1) Remove two screws (1) and lens retainer (2) from housing (3).
- (2) Remove three nuts (4), resilient mounts (5), washers (6), and lockwashers (7) from housing (3). Discard lockwashers.
- (3) Remove three adapters (8) and grommets (9) from housing (3). Discard grommets.

c. Assembly.

- (1) Install three grommets (1) and adapters (2) on housing (3).
- (2) Install three resilient mounts (4) on housing (3) with three washers (5), lockwashers (6), and nuts (7).
- (3) Install lens retainer (8) on housing (3) with three screws (9).

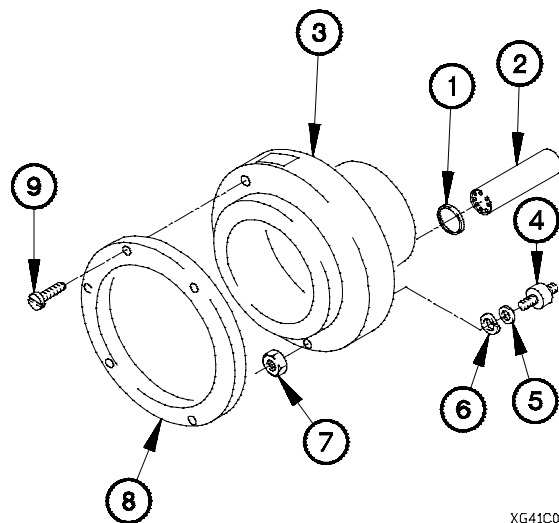

7-41. HEADLIGHT AND HOUSING REPLACEMENT/REPAIR/ADJUSTMENT (CONT)

d. Installation.

NOTE

Both headlights are installed the same way.
Left headlight shown.

- (1) Position housing (1) on bumper (2) with three nuts (3).
- (2) Tighten three nuts (3) to 60-72 lb-in. (7-8 N·m).

NOTE

Connectors for right side are P13, P14, and P12.

- (3) Install connectors P20, P19, and P4 (4) to back of housing (1).

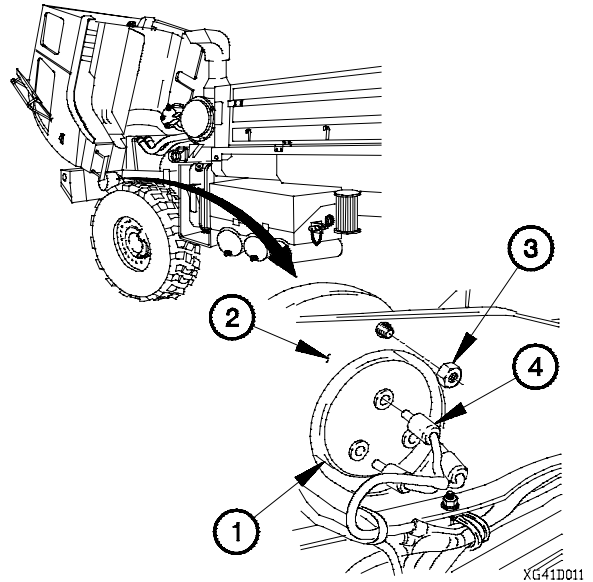

NOTE

- Perform steps (4) through (6) to install lamp only.
- Connector numbers are the same on left and right headlights.

- (4) Connect connectors 18, 91, and 17 (5) on housing (1).

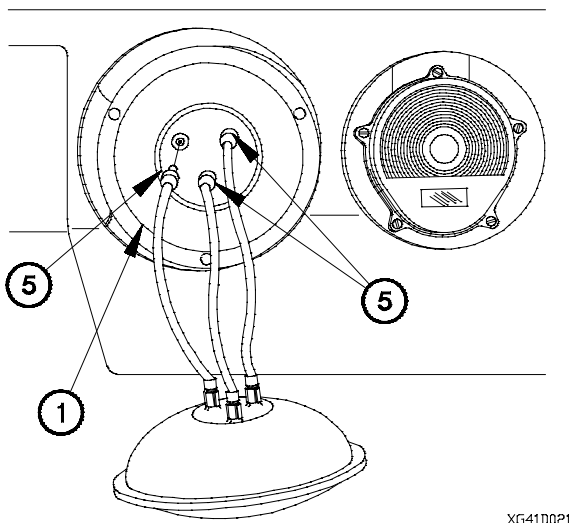

- (5) Install lamp (6) in housing (1).
- (6) Install retaining ring (7) on housing (1) with three screws (8).
- (7) Lower cab (TM 9-2320-366-10-1).

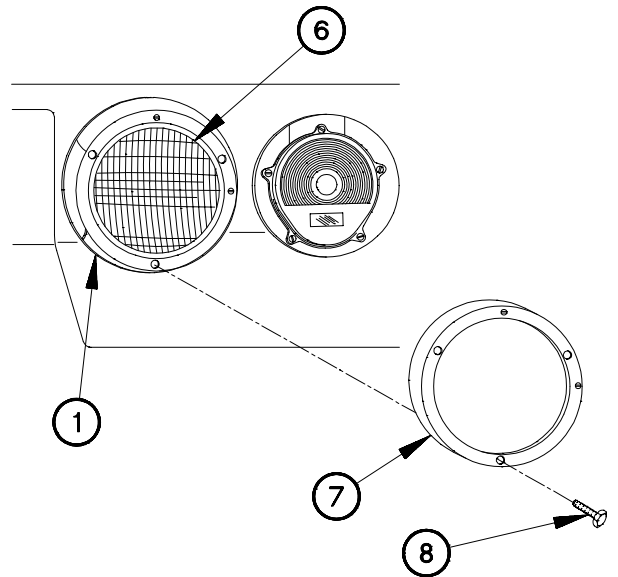

e. Adjustment.

NOTE

Vehicle must be empty when making headlight adjustment.

- (1) Connect batteries (para 7-57).
- (2) Position vehicle on level surface with both headlights approximately 36 in. (91 cm) from headlight adjustment screen with vertical lines (1) directly in front of bumper ends (2).
- (3) Turn headlights on LOW beam (TM 9-2320-366-10-1).

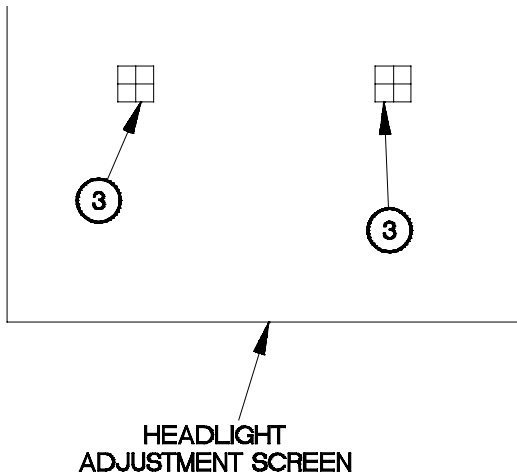
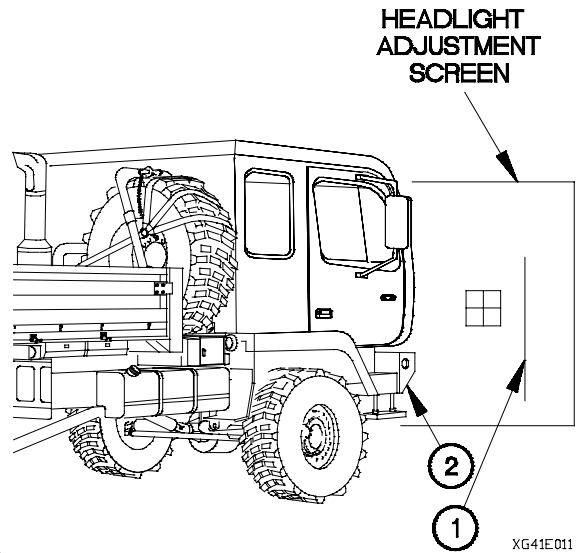

- (4) Observe headlight spots on headlight adjustment screen. If headlight spots are within squares (3), alignment is correct.

NOTE

Perform steps (5) and (6) if headlights need adjusting.

- (5) Adjust screw (4) to move headlight spot up or down.
- (6) Adjust screw (5) to move headlight spot left or right.
- (7) Turn off headlights (TM 9-2320-366-10-1).

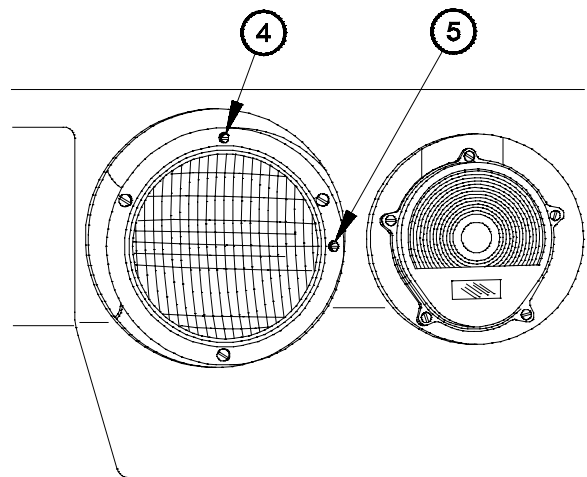

End of Task.

XG41E031

7-42. M1088/M1089 STATIONARY WORKLIGHT ASSEMBLY REPLACEMENT/REPAIR

This task covers:

- a. Removal
- b. Disassembly
- c. Assembly
- d. Installation
- e. Follow-On Maintenance

INITIAL SETUP

Equipment Conditions

Batteries disconnected (para 7-57).

Materials/Parts

Lockwasher (Item 96, Appendix G)

Tools and Special Tools

Tool Kit, Genl Mech (Item 46, Appendix C)

a. Removal.

NOTE

Left side and right side stationary worklight assemblies are removed the same way. Right side shown.

- (1) Disconnect worklight connector (1) from connector P134A (2).
- (2) Remove nut (3), lockwasher (4), washer (5) and worklight assembly (6) from vehicle. Discard lockwasher.

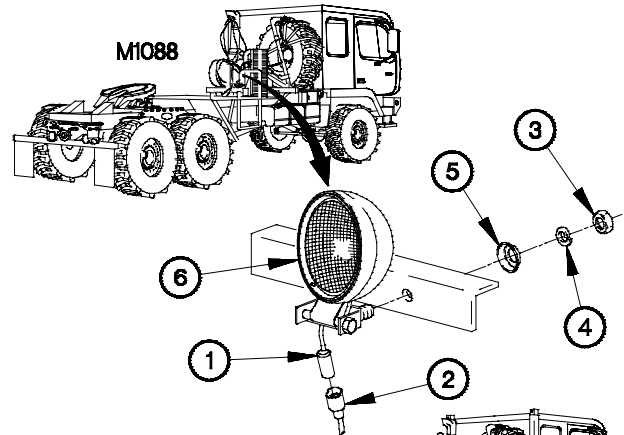

b. Disassembly.

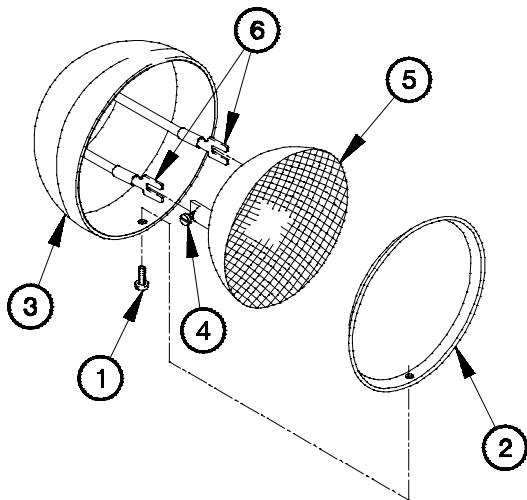

4G42B011

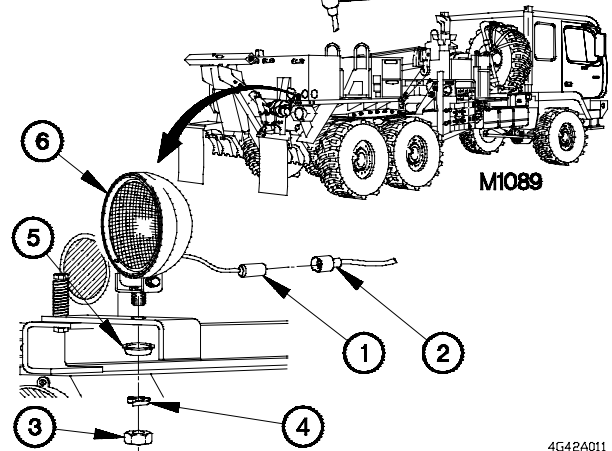

4G42A011

- (1) Remove screw (1) and retaining ring (2) from worklight assembly (3).
- (2) Loosen two screws (4) on back of lamp (5).
- (3) Disconnect two terminals (6) from lamp (5).

c. Assembly.

- (1) Install two terminals (1) on lamp (2) with two screws (3).
- (2) Install lamp (2) and retaining ring (4) on worklight assembly (5) with two screws (6).

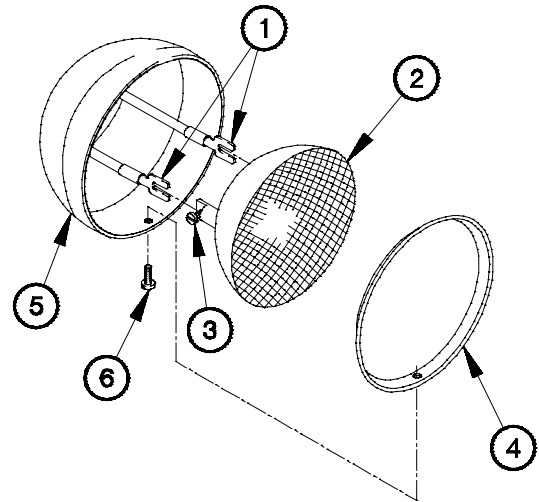

4G42C011

d. Installation.

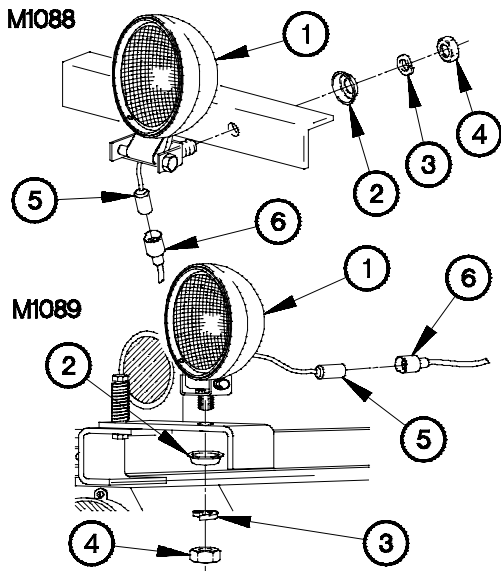

4G42D011

NOTE

Left side and right side stationary worklight assemblies are installed the same way. Right side shown.

- (1) Position worklight assembly (1) in mounting location on vehicle.
- (2) Install washer (2), lockwasher (3) and nut (4) on worklight assembly (1).
- (3) Connect worklight connector (5) to connector P134A (6).

e. Follow-On Maintenance.

- (1) Connect batteries (para 7-57).
- (2) Check operation of work light (TM 9-2320-366-10-1).

End of Task.

7-43. AUDIBLE ALARM REPLACEMENT	
This task covers:	
a. Removal b. Installation	c. Follow-On Maintenance
INITIAL SETUP	
Equipment Conditions Instrument panel assembly removed for access (para 7-15).	Materials/Parts Dispenser, Pressure Sensitive Adhesive Tape (Item 20, Appendix D)
Tools and Special Tools Tool Kit, Genl Mech (Item 46, Appendix C)	

a. Removal.

- (1) Disconnect connector PX7 (1) from lighted indicator display (2).

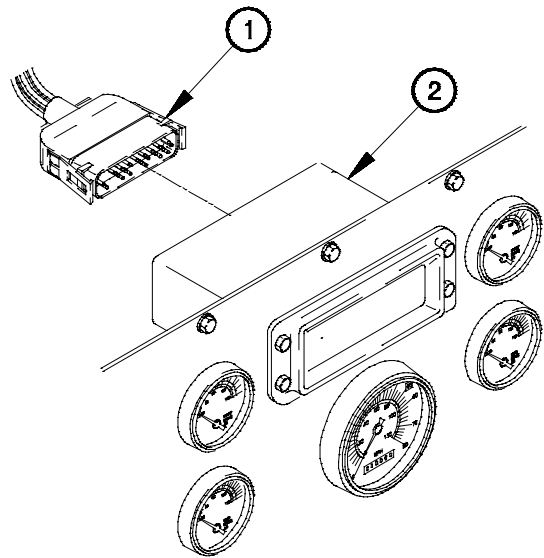

XG43R01B

- (2) Remove lock ring (3) and audible alarm (4) from instrument panel assembly (5).

NOTE

- Tag wires and connection points prior to disconnecting.
- Perform step (3) on M1084, M1086, M1088, and M1089.

- (3) Remove two screws (6) and terminal lugs TL161 (7) and TL160 (8) from audible alarm (4).

NOTE

Perform steps (4) and (5) on all models except M1084, M1086, M1088, and M1089.

- (4) Remove two screws (6) and terminal lugs TL161 (7) and TL178 (8) from audible alarm (4).

- (5) Remove screw (9) and TL160 (10) from audible alarm (4).

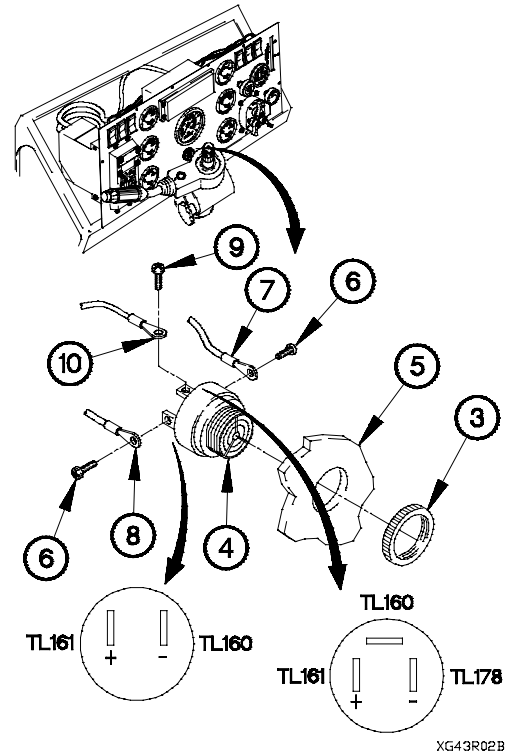

XG43R02B

b. Installation.

NOTE

Perform steps (1) and (2) on all models except M1084, M1086, M1088, and M1089.

- (1) Install terminal lug TL160 (1) on audible alarm (2) with screw (3).
- (2) Install terminal lugs TL161 (4) and TL178 (5) on audible alarm (2) with two screws (6).

NOTE

Perform step (3) on M1084, M1086, M1088, and M1089.

- (3) Install terminal lugs TL160 (5) and TL161 (4) on audible alarm (2) with two screws (6).
- (4) Install audible alarm (2) in instrument panel assembly (7) with lock ring (8).

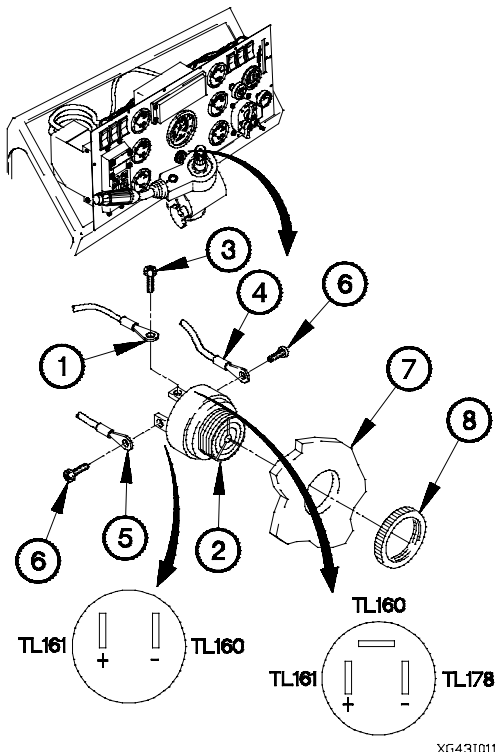

XG43I011

- (5) Connect connector PX7 (9) to lighted indicator display (10).

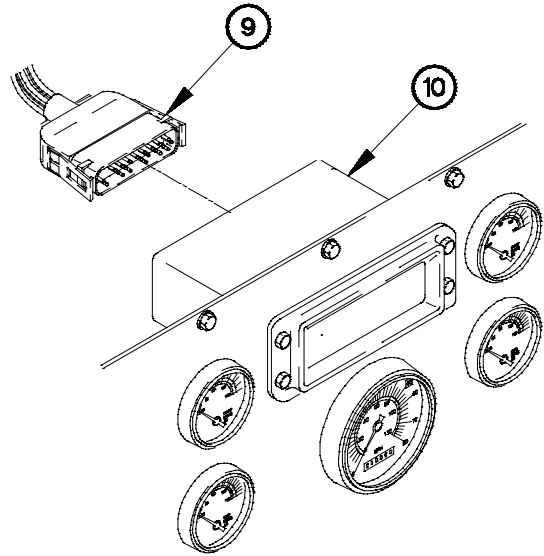

XG43102B

c. Follow-On Maintenance.

- (1) Install instrument panel assembly (para 7-15).
- (2) Check operation of audible alarm (TM 9-2320-366-10-1).

End of Task.

7-44. AIR PRESSURE TRANSMITTER REPLACEMENT

This task covers:

- | | |
|---|--|
| <ul style="list-style-type: none"> a. Removal b. Installation | <ul style="list-style-type: none"> c. Follow-On Maintenance |
|---|--|

INITIAL SETUP

Equipment Conditions

- Batteries disconnected (para 7-57).
- Air tanks drained (TM 9-2320-366-10-1).

Tools and Special Tools

- Tool Kit, Genl Mech (Item 58, Appendix C)

Materials/Parts

- Dispenser, Pressure Sensitive Adhesive Tape (Item 20, Appendix D)
- Antiseize Compound (Item 13, Appendix D)
- Lockwasher (2) (Item 71, Appendix G)

a. Removal.

NOTE

- Tag wires and connection points prior to disconnecting.
- Front brake air pressure transmitter and rear brake air pressure transmitter are removed the same way. Rear brake air pressure transmitter shown.
- Terminal lugs on front brake air pressure transmitter are TL150 for terminal G and TL156 for terminal WK.

- (1) Remove nut (1), lockwasher (2), and terminal lug TL151 (3) from air pressure transmitter terminal G (4). Discard lockwasher.
- (2) Remove nut (5), lockwasher (6), and terminal lug TL157 (7) from air pressure transmitter terminal WK (8).
- (3) Remove air pressure transmitter (9) from reducer (10).

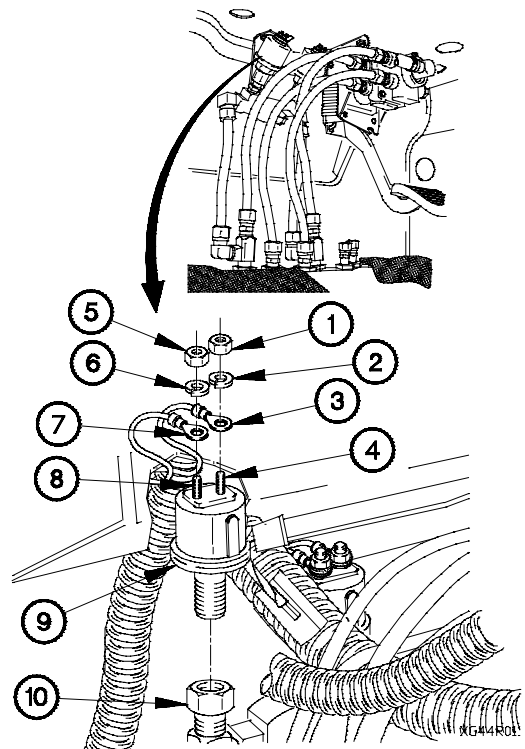

b. Installation.**WARNING**

Adhesives, solvents, and sealing compounds can burn easily, can give off harmful vapors, and are harmful to skin and clothing. Keep away from open fire and use in a well-ventilated area. If adhesive, solvent, or sealing compound gets on skin or clothing, wash immediately with soap and water. Failure to comply may result in injury to personnel.

- (1) Apply antiseize compound to threads of air pressure transmitter (1).
- (2) Install air pressure transmitter (1) in reducer (2).

NOTE

- Front brake air pressure transmitter and rear brake air pressure transmitter are installed the same way. Rear brake air pressure transmitter shown.
 - Terminal lugs on front brake air pressure transmitter are TL150 for terminal G and TL156 for terminal WK.
- (3) Install terminal lug TL157 (3) on air pressure transmitter terminal WK (4) with lockwasher (5) and nut (6).
 - (4) Install terminal lug TL151 (7) on air pressure transmitter terminal G (8) with lockwasher (9) and nut (10).

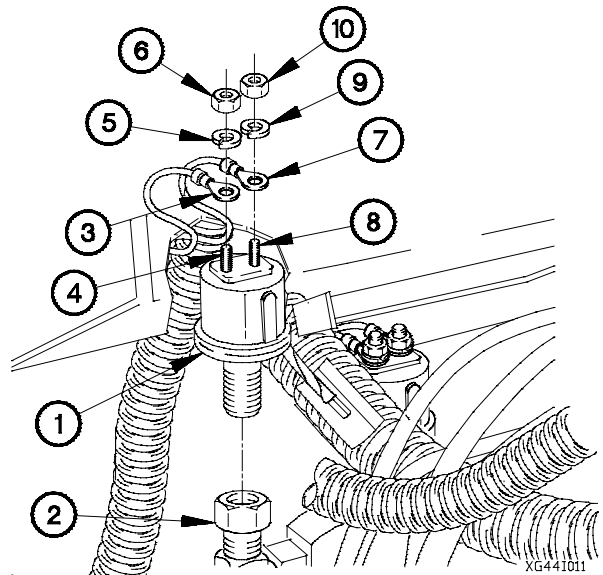
**c. Follow-On Maintenance.**

- (1) Connect batteries (para 7-57).
- (2) Start engine (TM 9-2320-366-10-1).
- (3) Check FRONT BRAKE AIR and REAR BRAKE AIR pressure gage operation (TM 9-2320-366-10-1).
- (4) Shut down engine (TM 9-2320-366-10-1).

End of Task.

7-45. COOLANT TEMPERATURE GAGE SENSOR REPLACEMENT

This task covers:

- a. Removal
- b. Installation
- c. Follow-On Maintenance

INITIAL SETUP

Equipment Conditions

Cab raised (TM 9-2320-366-10-1).
 Batteries disconnected (para 7-57).

Materials/Parts

Sealing Compound (Item 58, Appendix D)

Tools and Special Tools

Tool Kit, Genl Mech (Item 46, Appendix C)

a. Removal.

NOTE

Perform steps (1) through (3) on coolant temperature gage sensors equipped with a connector clamp.

- (1) Disconnect connector clamp (1) from coolant temperature gage sensor (2).
- (2) Disconnect connector P41 (3) from coolant temperature gage sensor (2).
- (3) Remove coolant temperature gage sensor (2) from adapter (4).

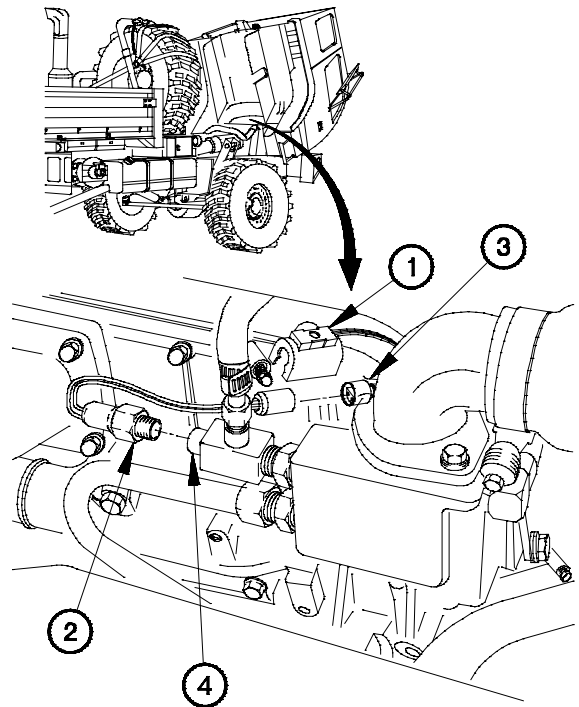

XG45R01B

NOTE

Perform steps (4) and (5) on coolant temperature gage sensors not equipped with a connector clamp.

- (4) Disconnect connector P41 (3) from coolant temperature gage sensor (2).
- (5) Remove coolant temperature gage sensor (2) from adapter (4).

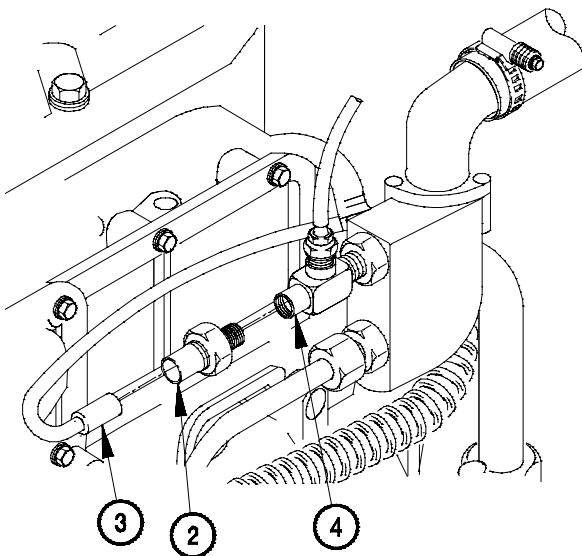

XG45R02B

b. Installation.**WARNING**

Adhesives, solvents, and sealing compounds can burn easily, can give off harmful vapors, and are harmful to skin and clothing. Keep away from open fire and use in a well-ventilated area. If adhesive, solvent, or sealing compound gets on skin or clothing, wash immediately with soap and water. Failure to comply may result in injury to personnel.

- (1) Apply antiseize compound to threads of coolant temperature gage sensor (1).
- (2) Install coolant temperature gage sensor (1) in adapter (2).
- (3) Connect connector P41 (3) to coolant temperature gage sensor (1).

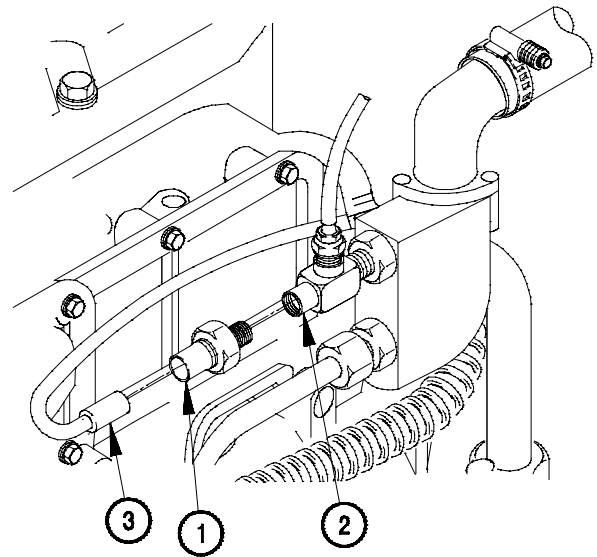

XG45I01B

c. Follow-On Maintenance.

- (1) Connect batteries (para 7-57).
- (2) Lower cab (TM 9-2320-366-10-1).
- (3) Start engine (TM 9-2320-366-10-1).
- (4) Check coolant temperature gage operation (TM 9-2320-366-10-1).
- (5) Shut down engine (TM 9-2320-366-10-1).

End of Task.

7-46. ENGINE SPEED SENSOR REPLACEMENT/ADJUSTMENT

This task covers:

- a. Removal
- b. Installation
- c. Adjustment

INITIAL SETUP

Equipment Conditions

Cab raised (TM 9-2320-366-10-1).
 Batteries disconnected (para 7-57).

Tools and Special Tools

Tool Kit, Genl Mech (Item 46, Appendix C)
 STE/ICE-R (Item 41, Appendix C)

Materials/Parts

Ties, Cable, Plastic (Item 69, Appendix D)

References

TM 9-4910-571-12&P

a. Removal.

- (1) Disconnect connector clamp (1) from engine speed sensor connector (2).
- (2) Disconnect engine speed sensor connector (2) from connector P38 (3).
- (3) Loosen jam nut (4) on engine speed sensor (5).
- (4) Remove engine speed sensor (5) from flywheel housing (6).

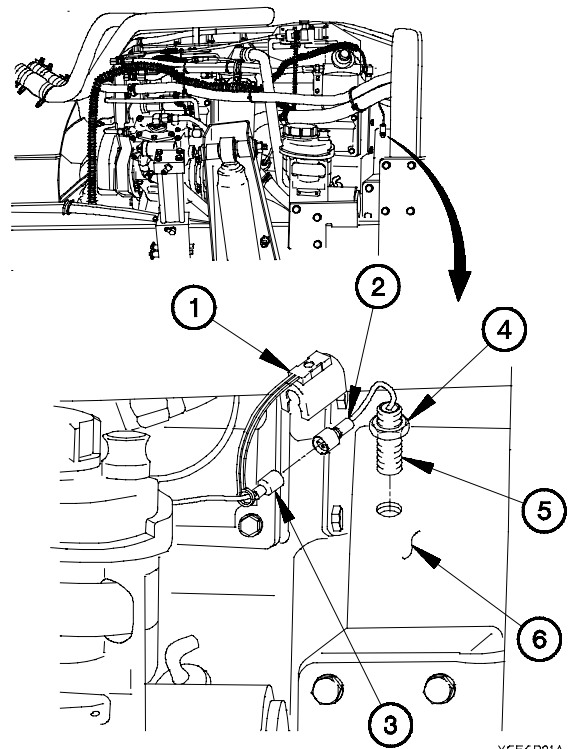

XG56R01A

b. Installation.

- (1) Turn engine speed sensor (5) to the right in fly wheel housing (6) until engine speed sensor contacts fly wheel.
- (2) Turn engine speed sensor (5) to the left out of fly wheel housing (6) two full turns.
- (3) Tighten jam nut (4) on engine speed sensor (5).
- (4) Connect engine speed sensor connector (2) to connector P38 (3).
- (5) Connect connector clamp (1) on engine speed sensor connector (2).

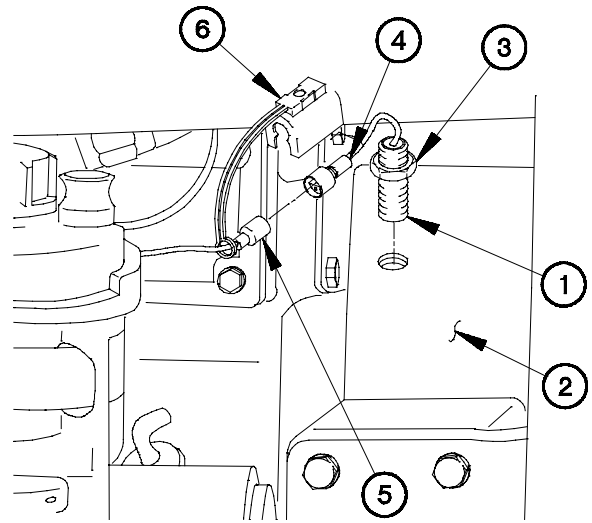

XG56101A

c. Adjustment.

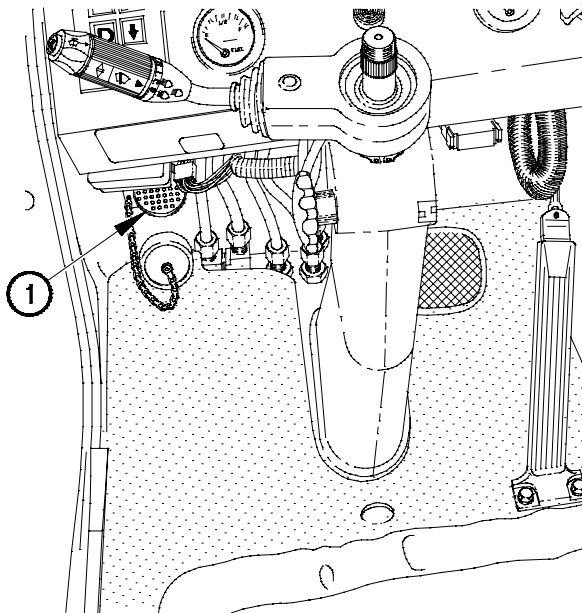

STEERING WHEEL
REMOVED FOR CLARITY

XG46C011

- (1) Lower cab (TM 9-2320-366-10-1).
- (2) Connect batteries (para 7-57).

NOTE

Perform step (3) on vehicles not equipped with tachometer.

- (3) Connect STE/ICE-R to DCA connector (1).
- (4) Start engine (TM 9-2320-366-10-1).

NOTE

- Perform step (5) on vehicles equipped with tachometer.
- If engine speed is not obtained in steps (5) or (6), perform steps (7) through (13).

- (5) Depress accelerator pedal and check tachometer operation (TM 9-2320-366-10-1).

NOTE

Perform step (3) on vehicles not equipped with tachometer.

- (6) Perform STE/ICE-R test 10 and verify engine speed (TM 9-4910-571-12&P).

7-46. ENGINE SPEED SENSOR REPLACEMENT/ADJUSTMENT (CONT)

- (7) Shut down engine (TM 9-2320-366-10-1).
- (8) Raise cab (TM 9-2320-366-10-1).
- (9) Loosen jam nut (2) on engine speed sensor (3).
- (10) Turn engine speed sensor (3) right one-quarter turn.
- (11) Tighten jam nut (2) on engine speed sensor (3).
- (12) Lower cab (TM 9-2320-366-10-1).
- (13) Repeat steps (4) through (12) to verify engine speed.
- (14) If engine speed is not obtained, perform engine troubleshooting.
- (15) Shut down engine (TM 9-2320-366-10-1).

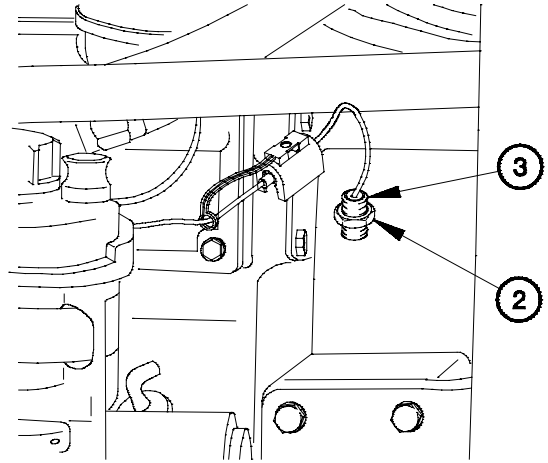

XG46C021

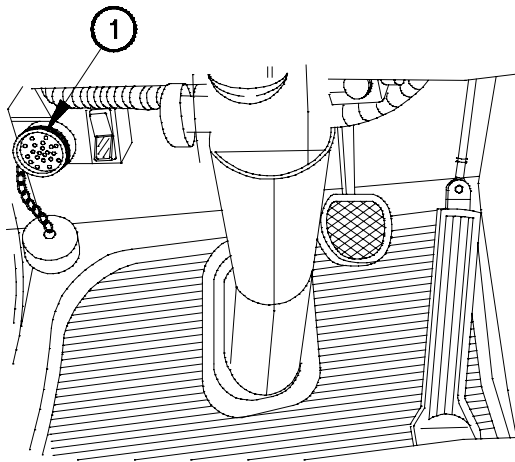

XG46C031

NOTE

Perform step (16) on vehicles not equipped with tachometer.

- (16) Disconnect STE/ICE-R from DCA connector (1).

End of Task.

7-47. ETHER SENSOR REPLACEMENT

This task covers:

- a. Removal
- b. Installation
- c. Follow-On Maintenance

INITIAL SETUP

Equipment Conditions

Cab raised (TM 9-2320-366-10-1).
Batteries disconnected (para 7-57).

Materials/Parts

Antiseize Compound (Item 13, Appendix D)

Tools and Special Tools

Tool Kit, Genl Mech (Item 46, Appendix C)
Goggles, Industrial (Item 15, Appendix C)

WARNING

- Coolant may be very hot and under pressure from engine operation. Ensure engine is cool before performing maintenance. Failure to comply may result in injury to personnel.
- Wear appropriate eye protection when working under vehicle due to the possibility of falling debris. Failure to comply may result in injury to personnel.

a. Removal.

- (1) Remove radiator cap (1) from radiator overflow tank (2).
- (2) Position container under radiator draincock (3).
- (3) Open radiator draincock (3) and drain approximately one gallon (one L) of coolant.
- (4) Close radiator draincock (3).

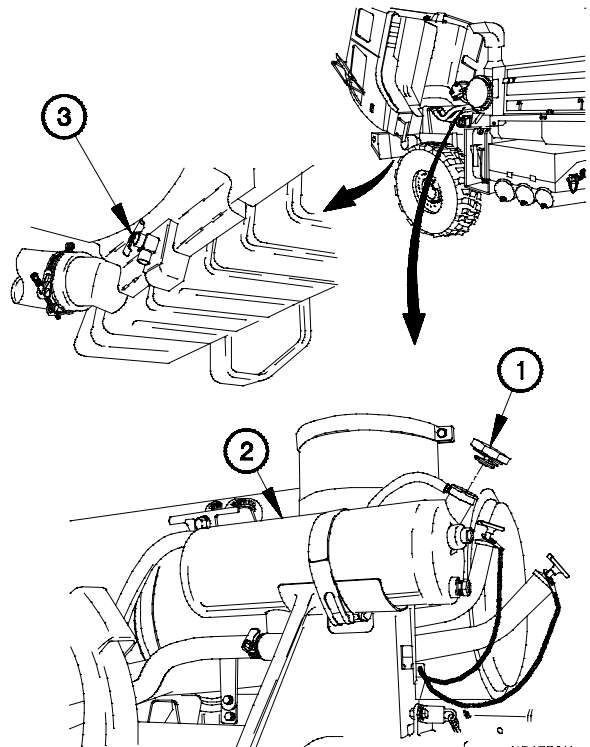

XG47R011

7-47. ETHER SENSOR REPLACEMENT (CONT)

- (5) Disconnect connector clamp (4) from ether sensor connector (5).
- (6) Disconnect connector P42 (6) from ether sensor connector (5).
- (7) Remove ether sensor (7) from coolant bypass tube (8).

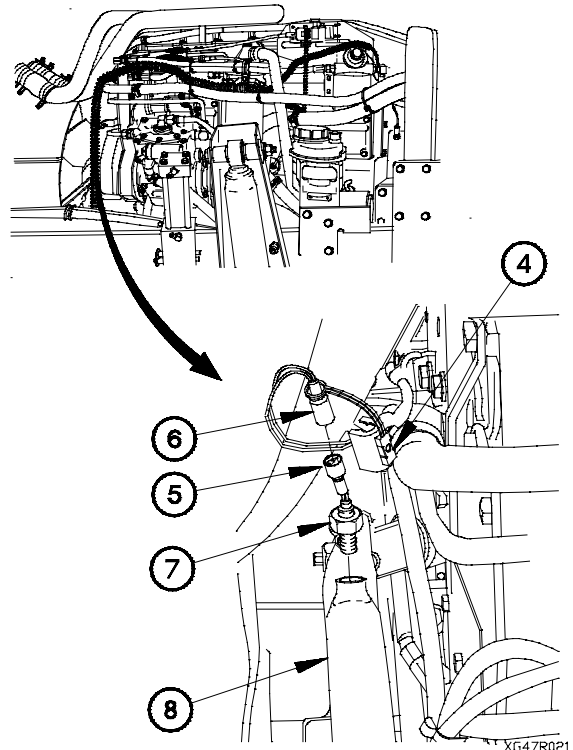

b. Installation.

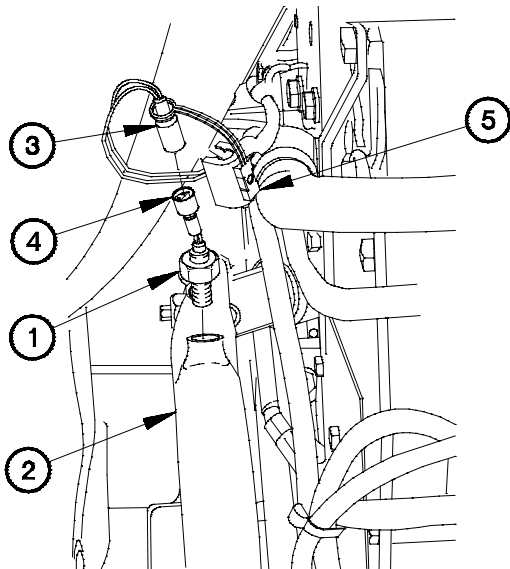

XG471011

WARNING

Adhesives, solvents, and sealing compounds can burn easily, can give off harmful vapors, and are harmful to skin and clothing. Keep away from open fire and use in a well-ventilated area. If adhesive, solvent, or sealing compound gets on skin or clothing, wash immediately with soap and water. Failure to comply may result in injury to personnel.

- (1) Apply antiseize compound to threads of ether sensor (1).
- (2) Install ether sensor (1) in coolant bypass tube (2).
- (3) Connect connector P42 (3) to ether sensor connector (4).
- (4) Connect connector clamp (5) on ether sensor connector (4).

c. Follow-On Maintenance.

- (1) Add coolant to radiator overflow tank (TM 9-2320-366-10-2).
- (2) Connect batteries (para 7-57).
- (3) Lower cab (TM 9-2320-366-10-1).
- (4) Start engine (TM 9-2320-366-10-1).
- (5) Check for coolant leaks under vehicle.
- (6) Check coolant level after normal temperature is reached. Add coolant as required (TM 9-2320-366-10-2).
- (7) Raise cab (TM 9-2320-366-10-1).
- (8) Check for coolant leaks around ether sensor.
- (9) Lower cab (TM 9-2320-366-10-1).
- (10) Shut down engine (TM 9-2320-366-10-1).

End of Task.

7-48. OIL PRESSURE SWITCH REPLACEMENT

This task covers:

- a. Removal
- b. Installation
- c. Follow-On Maintenance

INITIAL SETUP

Equipment Conditions

- Cab raised (TM 9-2320-366-10-1).
- Batteries disconnected (para 7-57).

Materials/Parts

- Antiseize Compound (Item 58, Appendix D)

Tools and Special Tools

- Tool Kit, Genl Mech (Item 46, Appendix C)

a. Removal.

- (1) Disconnect connector clamp (1) from connector J34 (2).
- (2) Disconnect connector P34 (3) from connector J34 (2).
- (3) Remove oil pressure switch (4) from fitting (5).

b. Installation.

WARNING

Adhesives, solvents, and sealing compounds can burn easily, can give off harmful vapors, and are harmful to skin and clothing. To avoid injury or death, keep away from open fire and use in a well-ventilated area. If adhesive, solvent, or sealing compound gets on skin or clothing, wash immediately with soap and water. Failure to comply may result in injury to personnel.

- (1) Apply antiseize compound to threads of oil pressure switch (4).
- (2) Install oil pressure switch (4) in fitting (5).
- (3) Connect connector P34 (3) to connector J34 (2).
- (4) Connect connector clamp (1) on connector J34 (2).

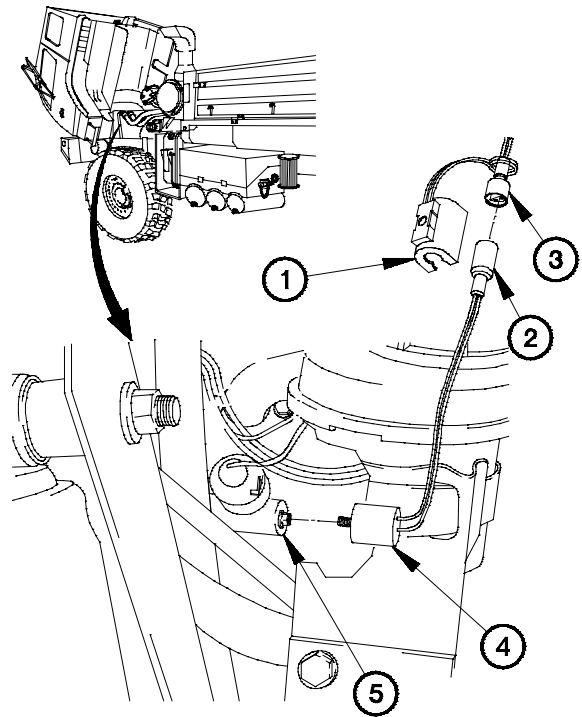

XG48X011

c. Follow-On Maintenance.

- (1) Connect batteries (para 7-57).
- (2) Lower cab (TM 9-2320-366-10-1).
- (3) Start engine (TM 9-2320-366-10-1).
- (4) Check that low oil pressure is not indicated (TM 9-2320-366-10-1).
- (5) Shut down engine (TM 9-2320-366-10-1).

End of Task.

7-49. OIL PRESSURE TRANSDUCER REPLACEMENT

This task covers:

- a. Removal
- b. Installation
- c. Follow-On Maintenance

INITIAL SETUP

Equipment Conditions

Cab raised (TM 9-2320-366-10-1).
 Batteries disconnected (para 7-57).

Materials/Parts

Antiseize Compound (Item 58, Appendix D)

Tools and Special Tools

Tool Kit, Genl Mech (Item 46, Appendix C)

a. Removal.

- (1) Disconnect connector P32 (1) from oil pressure transducer (2).
- (2) Remove oil pressure transducer (2) from fitting (3).

b. Installation.

WARNING

Adhesives, solvents, and sealing compounds can burn easily, can give off harmful vapors, and are harmful to skin and clothing. Keep away from open fire and use in a well-ventilated area. If adhesive, solvent, or sealing compound gets on skin or clothing, wash immediately with soap and water. Failure to comply may result in injury to personnel.

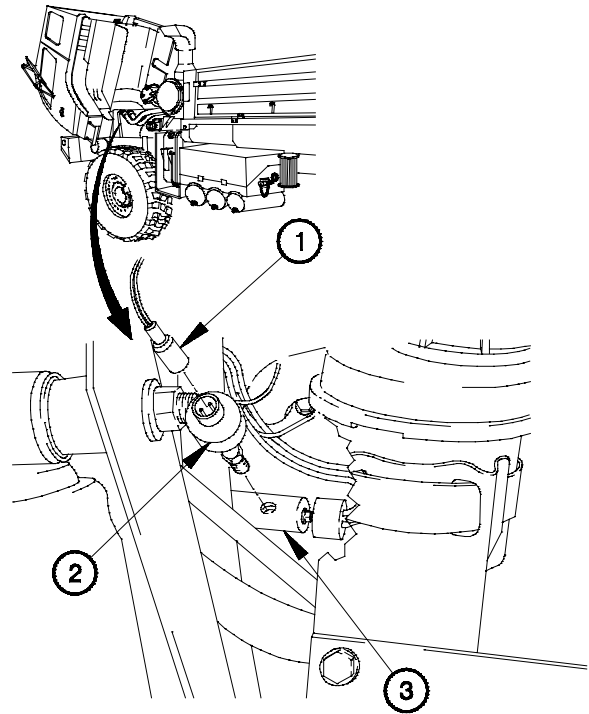

XG49X011

- (1) Apply antiseize compound to threads of oil pressure transducer (2).
- (2) Install oil pressure transducer (2) in fitting (3).
- (3) Connect connector P32 (1) to oil pressure transducer (2).

c. Follow-On Maintenance.

- (1) Connect batteries (para 7-57).
- (2) Lower cab (TM 9-2320-366-10-1).
- (3) Start engine (TM 9-2320-366-10-1).
- (4) Check oil pressure gage operation (TM 9-2320-366-10-1).
- (5) Shut down engine (TM 9-2320-366-10-1).

End of Task.

7-50. WATER TEMPERATURE SWITCH REPLACEMENT

This task covers:

- a. Removal
- b. Installation
- c. Follow-On Maintenance

INITIAL SETUP

Equipment Conditions

Cab raised (TM 9-2320-366-10-1).
 Batteries disconnected (para 7-57).

Tools and Special Tools

Tool Kit, Genl Mech (Item 46, Appendix C)
 Goggles, Industrial (Item 15, Appendix C)

WARNING

- Coolant may be very hot and under pressure from engine operation. Ensure engine is cool before performing maintenance. Failure to comply may result in injury to personnel.
- Wear appropriate eye protection when working under vehicle due to the possibility of falling debris. Failure to comply may result in injury to personnel.

a. Removal.

- (1) Remove radiator cap (1) from radiator overflow tank (2).
- (2) Position container under radiator draincock (3).
- (3) Open radiator draincock (3) and drain approximately one gallon (one L) of coolant.
- (4) Close radiator draincock (3).

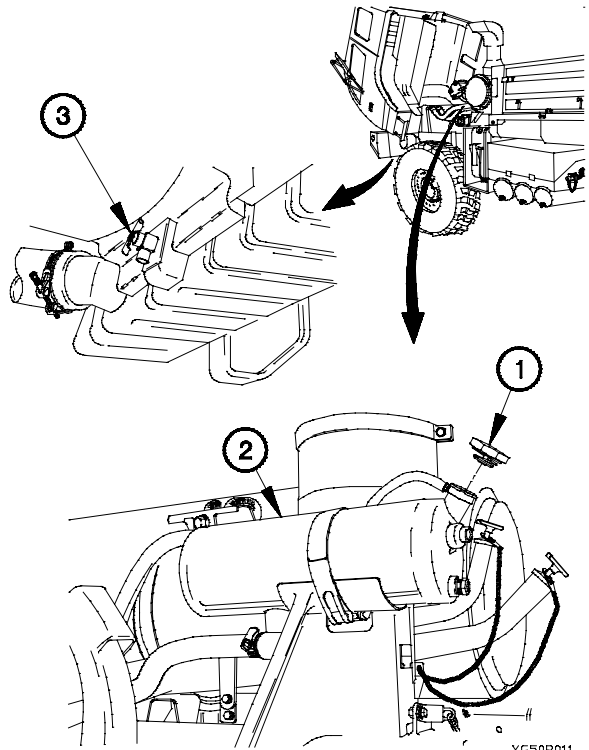

XG50R011

- (5) Disconnect connector clamp (4) from connector P36 (5).
- (6) Disconnect water temperature switch connector (6) from connector P36 (5).
- (7) Remove water temperature switch (7) from upper coolant tube (8).

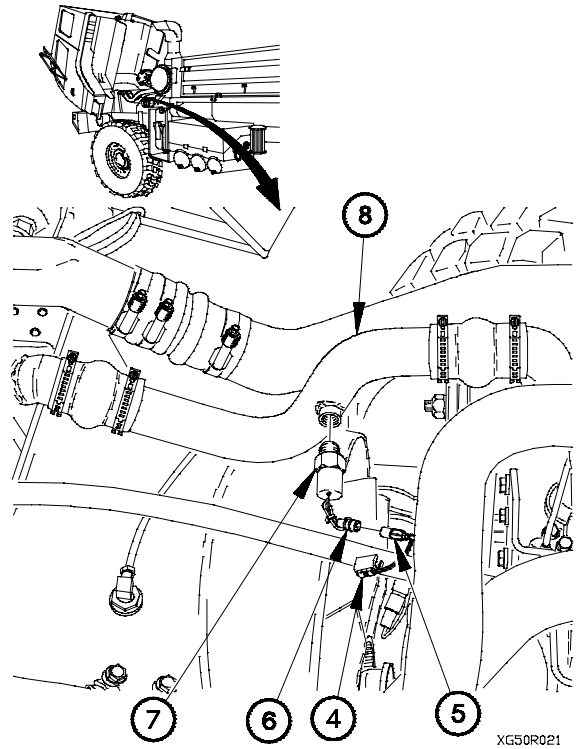

b. Installation.

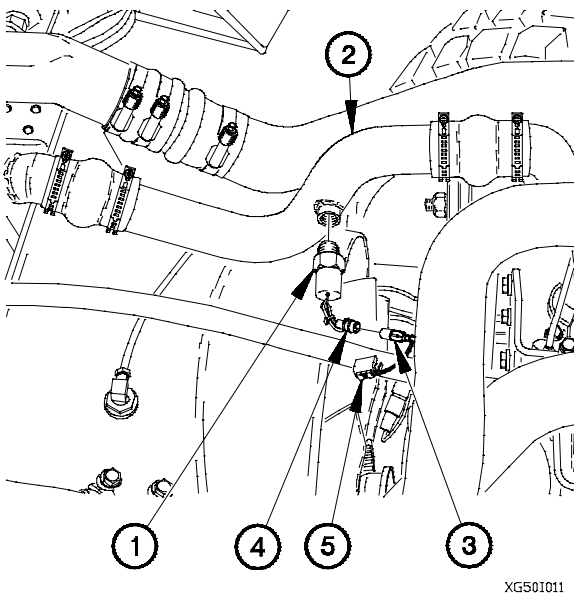

- (1) Install water temperature switch (1) in upper coolant tube (2).
- (2) Connect connector P36 (3) to water temperature switch connector (4).
- (3) Connect connector clamp (5) on connector P36 (3).

7-50. WATER TEMPERATURE SWITCH REPLACEMENT (CONT)

c. Follow-On Maintenance.

- (1) Add coolant to radiator overflow tank (TM 9-2320-366-10-2).
- (2) Connect batteries (para 7-57).
- (3) Lower cab (TM 9-2320-366-10-1).
- (4) Start engine (TM 9-2320-366-10-1).
- (5) Check for coolant leaks under vehicle.
- (6) Check coolant level after normal temperature is reached.
Add coolant as required (TM 9-2320-366-10-2).
- (7) Raise cab (TM 9-2320-366-10-1).
- (8) Check for leaks around water temperature switch.
- (9) Lower cab (TM 9-2320-366-10-1).
- (10) Shut down engine (TM 9-2320-366-10-1).

End of Task.

7-51. M1084/M1086 JACK CYLINDER PROXIMITY SENSOR REPLACEMENT	
This task covers:	
a. Removal b. Installation	c. Follow-On Maintenance
INITIAL SETUP	
Equipment Conditions Jack cylinders lowered (TM 9-2320-366-10-1). Engine shut down (TM 9-2320-366-10-1).	Materials/Parts Ties, Cable, Plastic (Item 69, Appendix D)
Tools and Special Tools Tool Kit, Genl Mech (Item 46, Appendix C)	Personnel Required (2)

a. Removal.

NOTE

Remove plastic cable ties as required.

- (1) Disconnect connector (1) from proximity sensor connector (2).

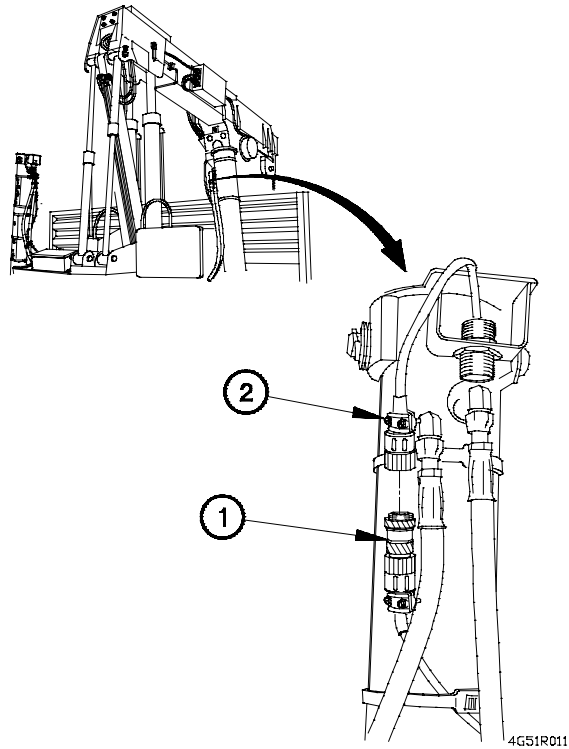

4G51R011

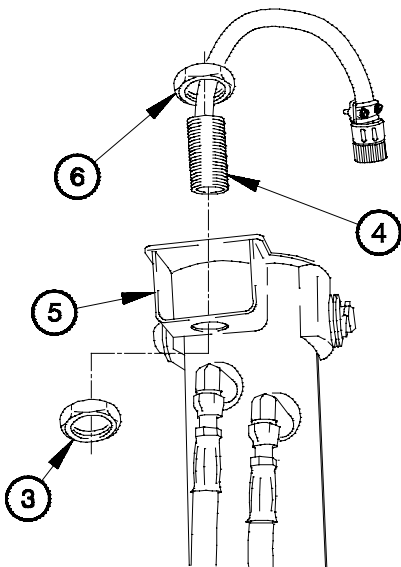

4G51R021

- (2) Remove nut (3) from proximity sensor (4).
- (3) Remove proximity sensor (4) from mounting bracket (5).
- (4) Remove nut (6) from proximity sensor (4).

7-51. M1084/M1086 JACK CYLINDER PROXIMITY SENSOR REPLACEMENT (CONT)

b. Installation.

- (1) Position nut (1) approximately 1 1/4 - 1 3/8 in. (3.2 - 3.5 cm) from bottom of proximity sensor (2).
- (2) Position proximity sensor (2) in mounting bracket (3) with nut (4).

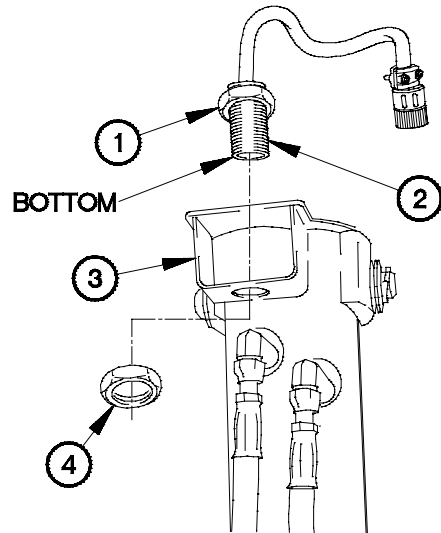

4G511011

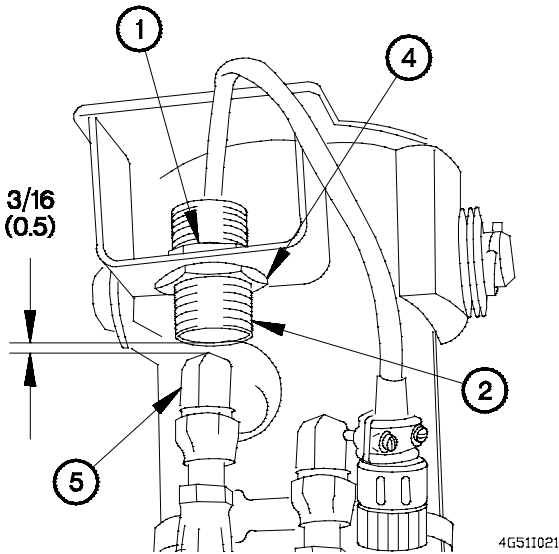

4G511021

- (3) Adjust proximity sensor (2) until gap between fitting (5) and proximity sensor is 3/16 in. (0.5 cm).
- (4) Tighten nuts (1 and 4).

NOTE

Install plastic cable ties as required.

- (5) Connect proximity sensor connector (6) to connector (7).

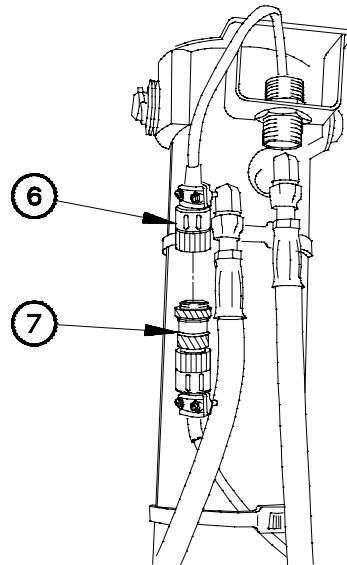

4G511031

c. Follow-On Maintenance.

Operate MHC and check jack cylinder operation (TM 9-2320-366-10-1).

End of Task.

7-52. TRANSMISSION ENGINE SPEED SENSOR REPLACEMENT	
This task covers:	
a. Removal b. Installation	c. Follow-On Maintenance
INITIAL SET-UP	
Equipment Conditions Batteries disconnected (para 7-57).	Materials/Parts Packing, Preformed (Item 199, Appendix G)
Tools and Special Tools Goggles, Industrial (Item 15, Appendix C) Tool Kit, Genl Mech (Item 46, Appendix C) Wrench, Torque, 0-175 lb-ft (Item 58, Appendix C)	

WARNING

Wear eye protection when working under vehicle due to the possibility of falling debris. Failure to comply may result in injury to personnel.

a. Removal.

- (1) Disconnect engine speed sensor connector (1) from transmission engine speed sensor (2).
- (2) Remove screw (3), transmission engine speed sensor bracket (4), and transmission engine speed sensor (2) from converter housing module (5).
- (3) Remove preformed packing (6) from transmission engine speed sensor (2). Discard preformed packing.

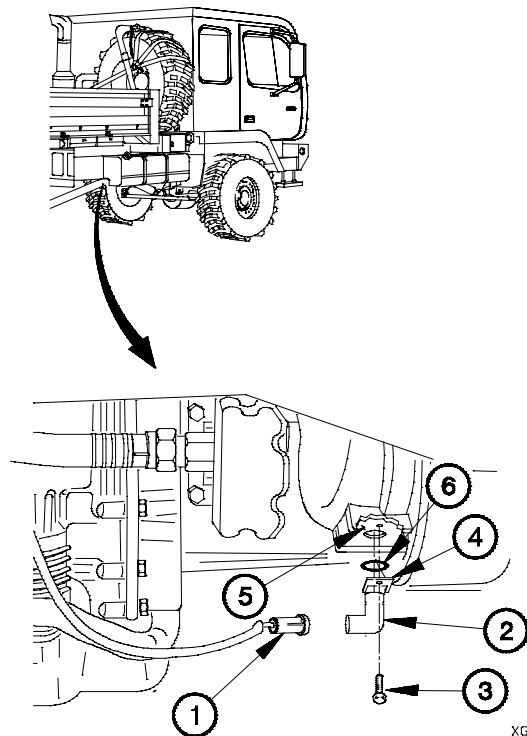

XG52R011

b. Installation.

- (1) Install preformed packing (1) on transmission engine speed sensor (2).
- (2) Position transmission engine speed sensor bracket (3) and transmission engine speed sensor (2) on converter housing module (4) with screw (5).
- (3) Tighten screw (5) to 22-26 lb-ft (30-35 N·m).
- (4) Connect engine speed sensor connector (6) to transmission engine speed sensor (2).

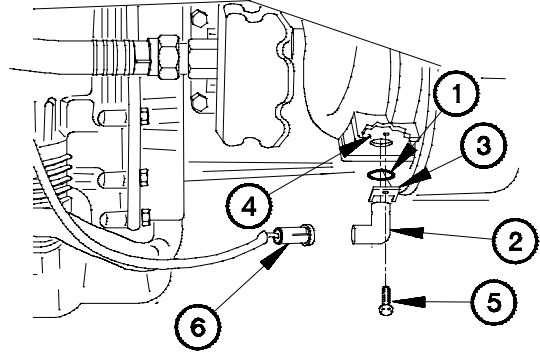

XG521011

c. Follow-On Maintenance.

- (1) Connect batteries (para 7-57).
- (2) Start engine (TM 9-2320-366-10-1).
- (3) Check for diagnostic codes logged (para 8-4 or 8-5).
- (4) Shut down engine (TM 9-2320-366-10-1).

End of Task.

7-53. HORN AND BRACKET REPLACEMENT	
This task covers:	
a. Removal b. Installation	c. Follow-On Maintenance
INITIAL SETUP	
Equipment Conditions Batteries disconnected (para 7-57).	Materials/Parts Dispenser, Pressure Sensitive Adhesive Tape (Item 20, Appendix D) Lockwasher (2) (Item 71, Appendix G)
Tools and Special Tools Tool Kit, Genl Mech (Item 46, Appendix C) Wrench, Torque, 0-200 lb-in. (Item 59, Appendix C) Socket Set, Socket Wrench (Item 34, Appendix C)	

a. Removal.

- (1) Remove two screws (1) and washers (2) from front grille (3).
- (2) Remove screw (4), washer (5), and front grille (3) from cab (6).

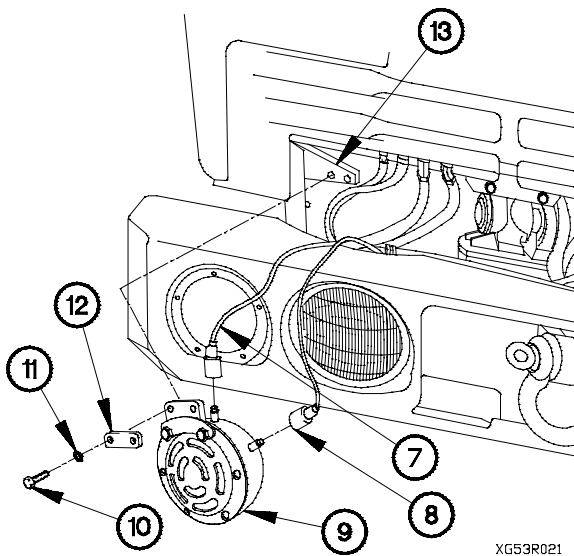
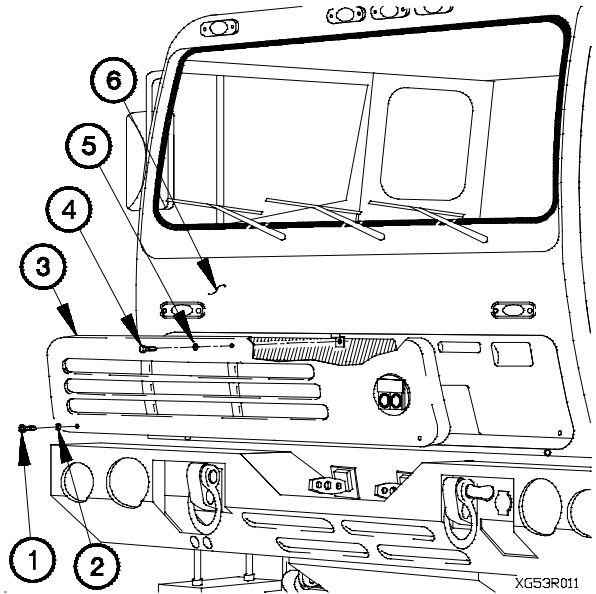

NOTE

Tag connectors and connection points prior to disconnecting.

- (3) Disconnect connectors P5 (7) and P6 (8) from horn (9).
- (4) Remove two screws (10), lockwashers (11), strap (12), and horn (9) from horn bracket (13). Discard lockwashers.

(5) Remove two screws (14), washers (15), and horn bracket (13) from cab (6).

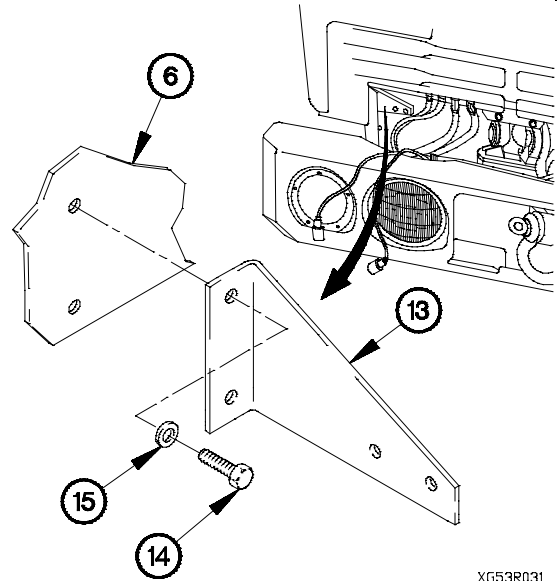

XG53R031

b. Installation.

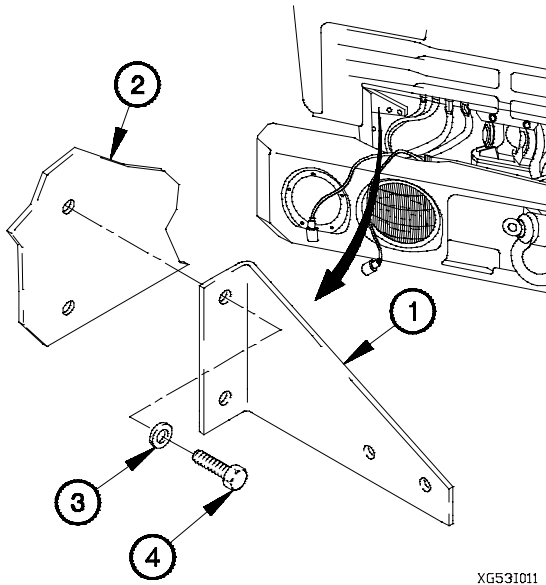

XG53I011

(1) Install horn bracket (1) on cab (2) with two washers (3) and screws (4).

(2) Position horn (5) on horn bracket (1) with strap (6), two lockwashers (7), and screws (8).

(3) Tighten two screws (8) to 96-120 lb-in. (11-14 N·m).

(4) Connect connectors P6 (9) and P5 (10) to horn (5).

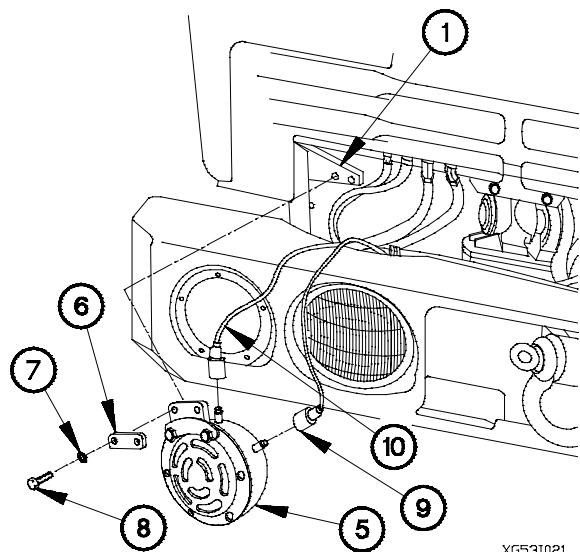

XG53I021

7-53. HORN AND BRACKET REPLACEMENT (CONT)

- (5) Position front grille (11) on cab (2) with washer (12) and screw (13).
- (6) Position two washers (14) and screws (15) in front grille (11).
- (7) Tighten screw (13) to 48-60 lb-in. (5-7 N·m).
- (8) Tighten two screws (15) to 24 lb-in. (3 N·m).

c. Follow-On Maintenance.

Connect batteries (para 7-57).

End of Task.

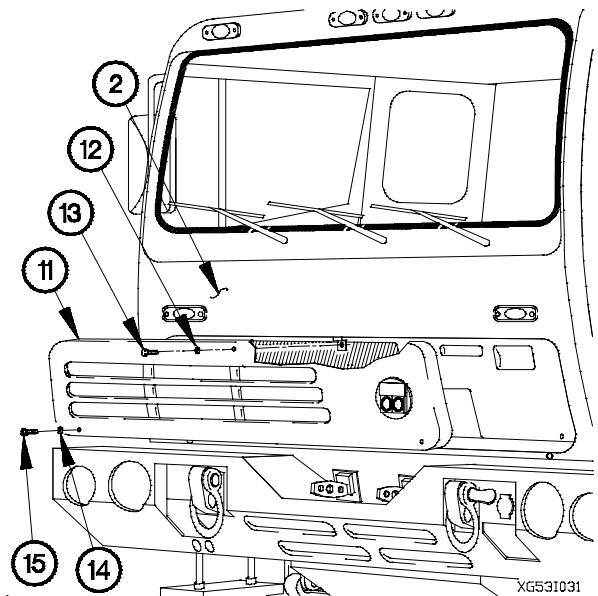

7-54. BATTERY TESTER REPLACEMENT

This task covers:

- a. Removal
- b. Installation
- c. Follow-On Maintenance

INITIAL SETUP

Equipment Conditions

- Engine shut down (TM 9-2320-366-10-1).
- Battery box cover removed (TM 9-2320-366-10-2).

Tools and Special Tools

- Goggles, Industrial (Item 15, Appendix C)
- Apron, Rubber (Item 3, Appendix C)
- Gloves, Rubber (Item 13, Appendix C)
- Puller, Battery Terminal (Item 28, Appendix C)
- Tool Kit, Genl Mech (Item 46, Appendix C)

Materials/Parts

- Dispenser, Pressure Sensitive Adhesive Tape (Item 20, Appendix D)
- Grease, Automotive and Artillery (GAA) (Item 22, Appendix D)
- Lockwasher (Item 87, Appendix G)



- Remove rings, bracelets, watches, necklaces, and any other jewelry before working around vehicle. Jewelry can catch on equipment and cause injury or short across electrical circuit and cause severe burns or electrical shock. Batteries can explode from a spark. Battery acid is harmful to skin and eyes. Always wear eye protection and rubber gloves when working with batteries. Failure to comply may result in injury to personnel.
- Negative battery terminals must be disconnected first. Failure to comply may result in serious injury or death to personnel.

a. Removal.

NOTE

Tag cables and connection points prior to disconnecting.

- (1) Remove nut (1) and lockwasher (2) from battery ground cable (3). Discard lockwasher.

NOTE

Perform step (2) on vehicles equipped with cargo arctic heater.

- (2) Remove terminal lug TL2 (4) from battery ground cable (3).
- (3) Remove terminal lugs TL50A (5), TL48 (6), and battery tester terminal lug (7) from battery ground cable (3).

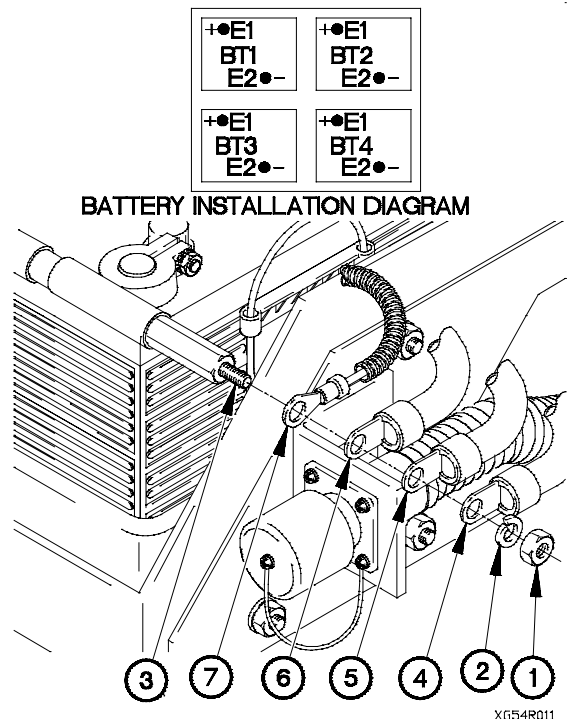

7-54. BATTERY TESTER REPLACEMENT (CONT)

NOTE

Remove battery terminal covers as required.

- (4) Loosen two terminal screws (8) on battery ground cable (3).
- (5) Remove battery ground cable (3) from battery terminals BT4 E2 (9) and BT3 E2 (10).

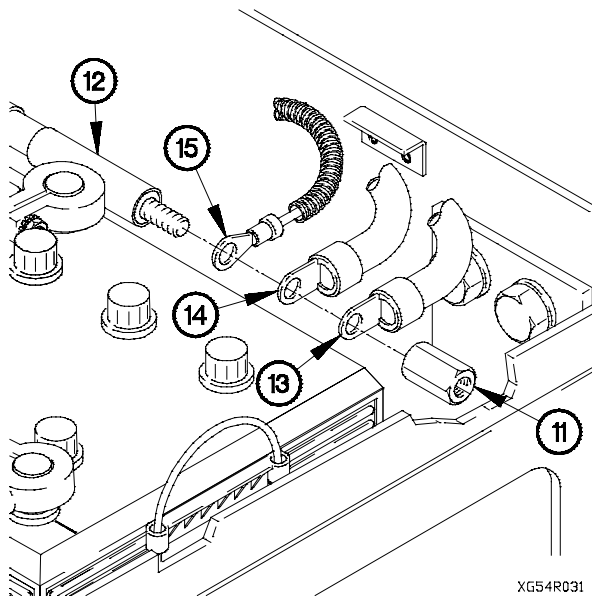
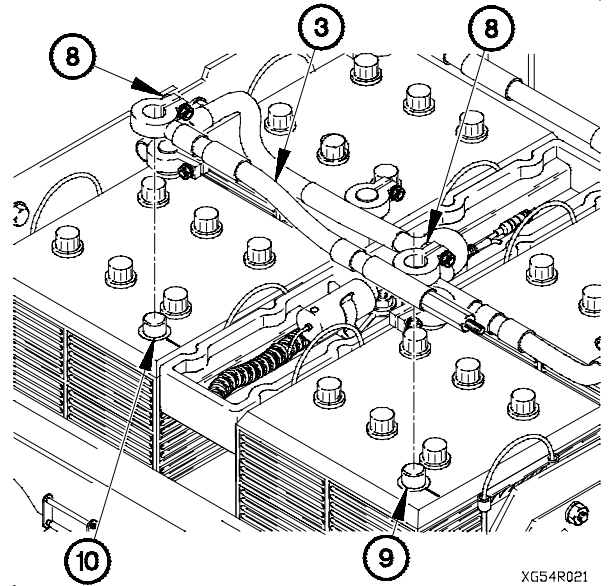

- (6) Remove nut (11) from battery 24 VDC cable (12).

NOTE

Perform step (7) on vehicles equipped with cargo arctic heater.

- (7) Remove terminal lug TL1 (13) from battery 24 VDC cable (12).
- (8) Remove terminal lug TL49A (14) and battery tester terminal lug (15) from battery 24 VDC cable (12).

- (9) Remove screw (16) and clamp (17) from battery hold-down bracket (18).
- (10) Remove battery tester (19) from spring clip (20).
- (11) Remove two screws (21) and spring clip (20) from battery hold-down bracket (18).

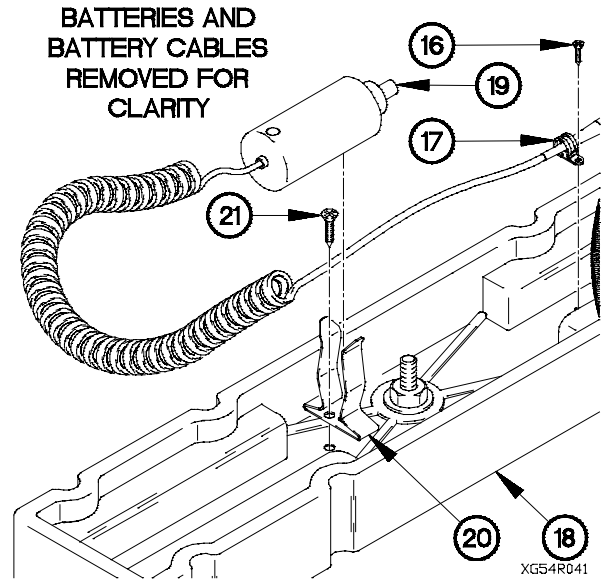

b. Installation.

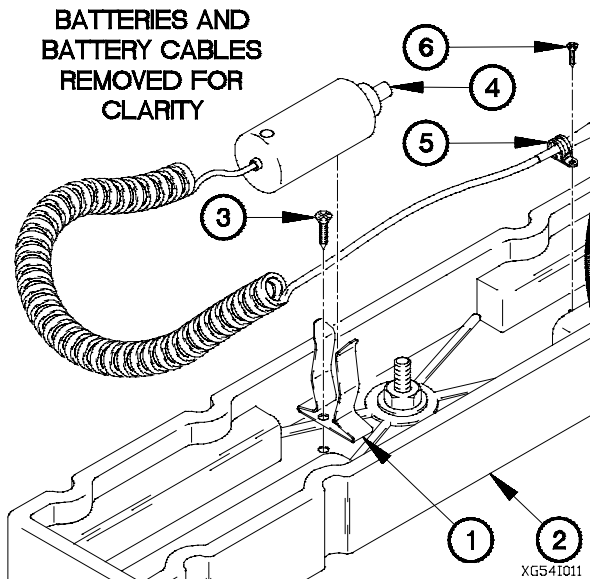

- (1) Install spring clip (1) on battery hold-down bracket (2) with two screws (3).
- (2) Install battery tester (4) in spring clip (1).
- (3) Install clamp (5) on battery hold-down bracket (2) with screw (6).

7-54. BATTERY TESTER REPLACEMENT (CONT)

WARNING

Negative battery terminals must be connected last. Failure to comply may result in serious injury or death to personnel.

- (4) Install battery tester terminal lug (7) and terminal lug TL49A (8) on battery 24 VDC cable (9).

NOTE

Perform step (5) on vehicles equipped with cargo arctic heater.

- (5) Install terminal lug TL1 (10) on battery 24 VDC cable (9).
- (6) Install nut (11) on battery 24 VDC cable (9).

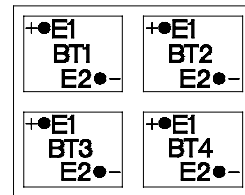

BATTERY INSTALLATION DIAGRAM

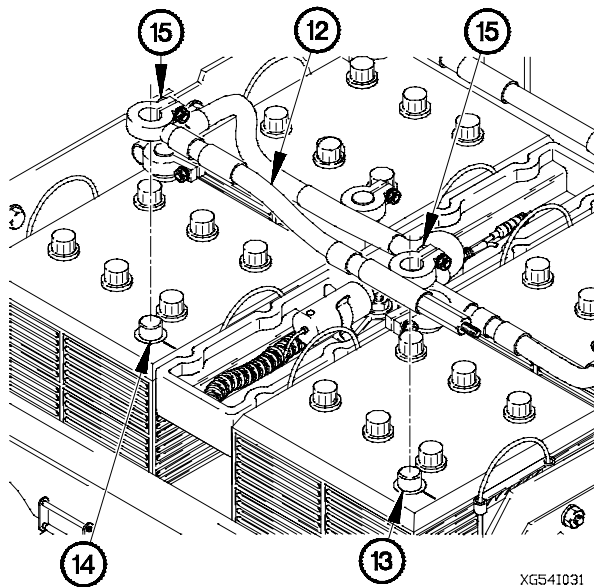
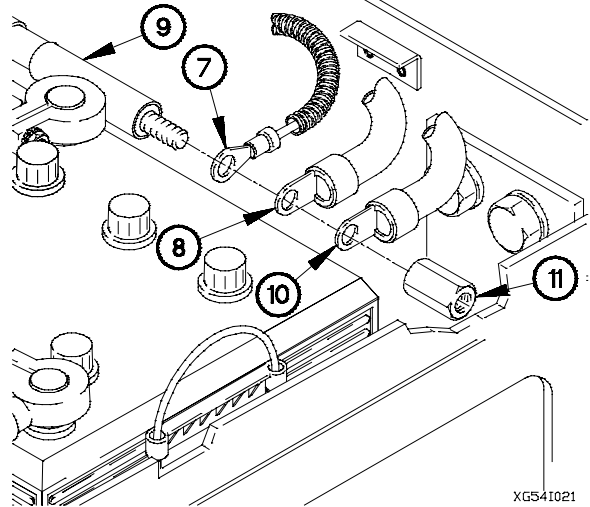

NOTE

Install battery terminal covers as required.

- (7) Install battery ground cable (12) on battery terminals BT4 E2 (13) and BT3 E2 (14).
- (8) Tighten two terminal screws (15) on battery ground cable (12).

- (9) Install battery tester terminal lug (16), and terminal lugs TL50A (17) and TL48 (18) on battery ground cable (12).

NOTE

Perform step (10) on vehicles equipped with cargo arctic heater.

- (10) Install terminal lug TL2 (19) on battery ground cable (12).
- (11) Install lockwasher (20) and nut (21) on battery ground cable (12).
- (12) Apply grease to all battery terminals.

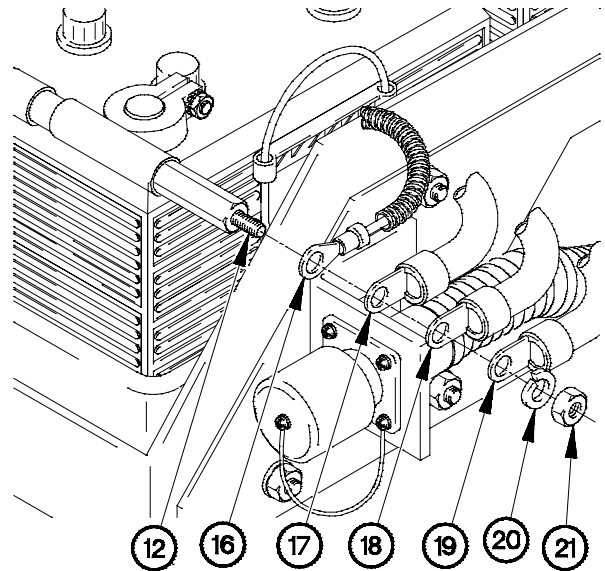

XG541041

c. Follow-On Maintenance.

Install battery box cover (TM 9-2320-366-10-2).

End of Task.

7-55. BATTERY/BATTERY CABLES REPLACEMENT	
This task covers:	
a. Removal b. Installation	c. Follow-On Maintenance
INITIAL SETUP	
Equipment Conditions Engine shut down (TM 9-2320-366-10-1). Battery box cover removed (TM 9-2320-366-10-2).	Materials/Parts Dispenser, Pressure Sensitive Adhesive Tape (Item 20, Appendix D) Grease, Automotive and Artillery (GAA) (Item 22, Appendix D) Lockwasher (Item 100, Appendix G)
Tools and Special Tools Tool Kit, Genl Mech (Item 46, Appendix C) Apron, Rubber (Item 3, Appendix C) Goggles, Industrial (Item 15, Appendix C) Gloves, Rubber (Item 13, Appendix C) Puller, Battery Terminal (Item 28, Appendix C)	References TM 9-6140-200-14

a. Removal.



- Remove rings, bracelets, watches, necklaces, and any other jewelry before working around vehicle. Jewelry can catch on equipment and cause injury or short across electrical circuit and cause severe burns or electrical shock. Batteries can explode from a spark. Battery acid is harmful to skin and eyes. Always wear eye protection and rubber gloves when working with batteries. Failure to comply may result in injury to personnel.
- Battery acid (electrolyte) is extremely harmful. Always wear safety goggles and rubber gloves, and do not smoke when performing maintenance on batteries. Injury will result if acid contacts skin or eyes. Wear rubber apron to prevent clothing being damaged. Failure to comply may result in injury to personnel.
- Negative battery terminals and battery tester negative terminal lug must be disconnected first. Failure to comply may result in serious injury or death to personnel.

NOTE

Tag cables and connection points prior to disconnecting.

- (1) Remove nut (1) and lockwasher (2) from battery ground cable (3). Discard lockwasher.
- (2) Deleted.
- (3) Remove terminal lugs TL50A (5), TL48 (6), battery tester terminal lug (7) and washer (4) from battery ground cable (3).

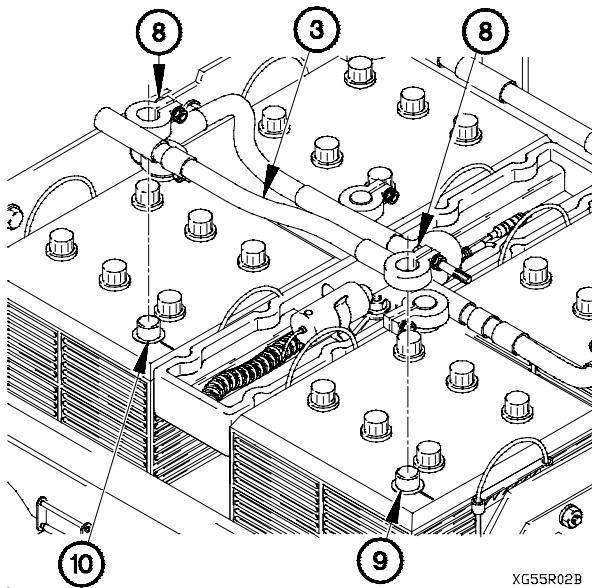

- (6) Remove nut (11) and terminal lug TL99 (12) from battery BT2 to BT4 12 vdc cable (13).

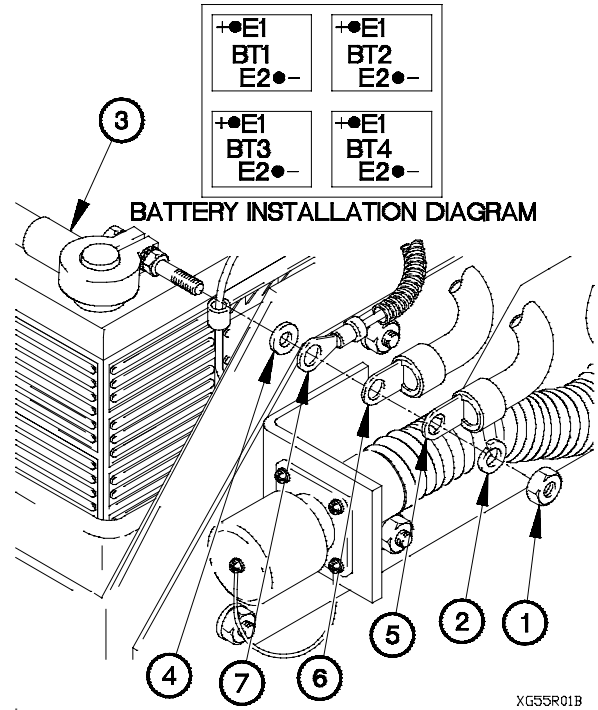

NOTE

Remove battery terminal covers as required.

- (4) Loosen two terminal screws (8) on battery ground cable (3).
- (5) Remove battery ground cable (3) from battery terminals BT4 E2 (9) and BT3 E2 (10).

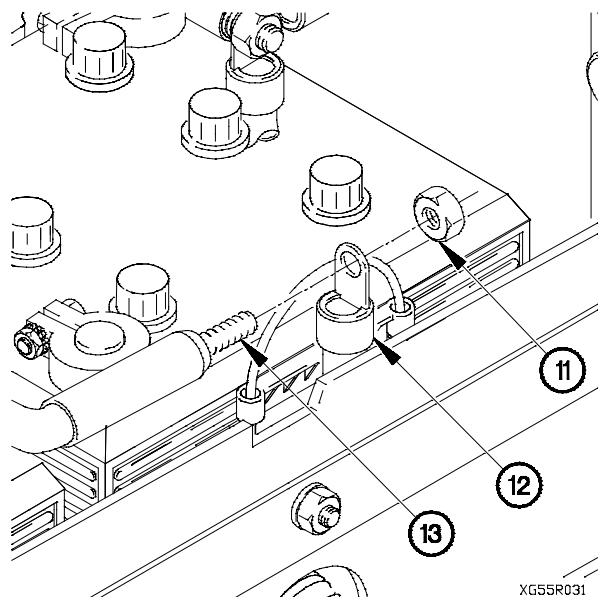

7-55. BATTERY/BATTERY CABLES REPLACEMENT (CONT)

- (7) Remove nut (14) and terminal lug TL136 (15) from battery BT2 to BT4 12 vdc cable (13).
- (8) Loosen two terminal screws (16) on battery BT4 to BT2 12 vdc cable (13).
- (9) Remove battery BT2 to BT4 12 vdc cable (13) from battery terminals BT4 E1 (17) and BT2 E2 (18).

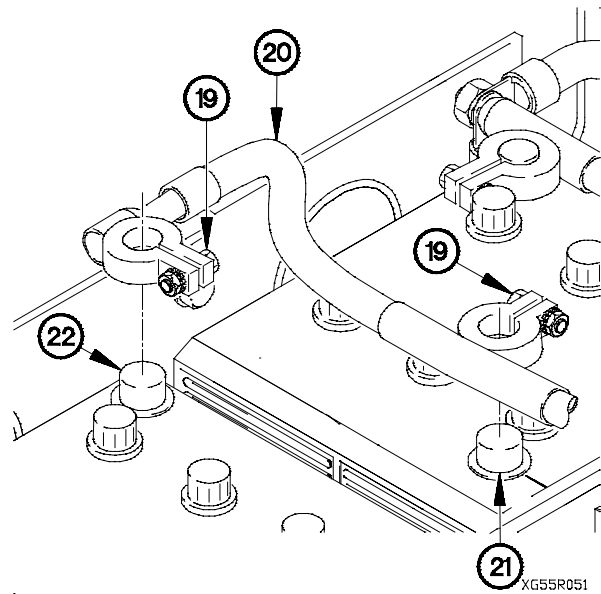
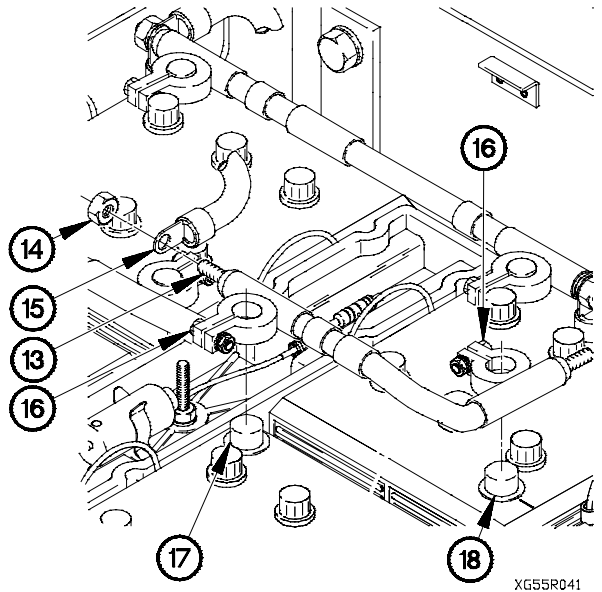

- (10) Loosen two terminal screws (19) on battery BT1 to BT3 12 vdc cable (20).
- (11) Remove battery BT1 to BT3 12 vdc cable (20) from battery terminals BT1 E2 (21) and BT3 E1 (22).

- (12) Remove nut (23) from battery 24 vdc cable (24).
- (13) Deleted.
- (14) Remove terminal lug TL49A (26) and battery tester terminal lug (27) from battery 24 vdc cable (24).

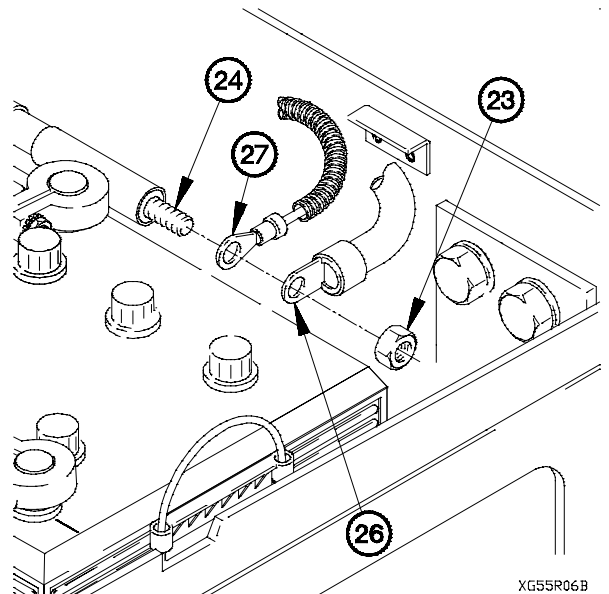

(15) Remove nut (28), and terminal lugs TL39 (29) and TL10 (30) from battery 24 vdc cable (24).

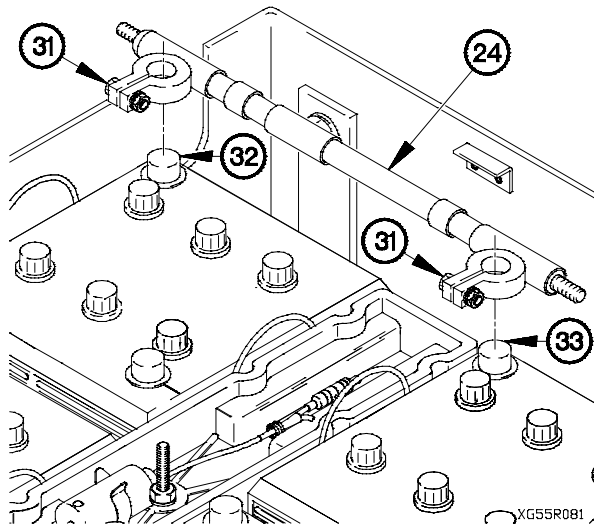
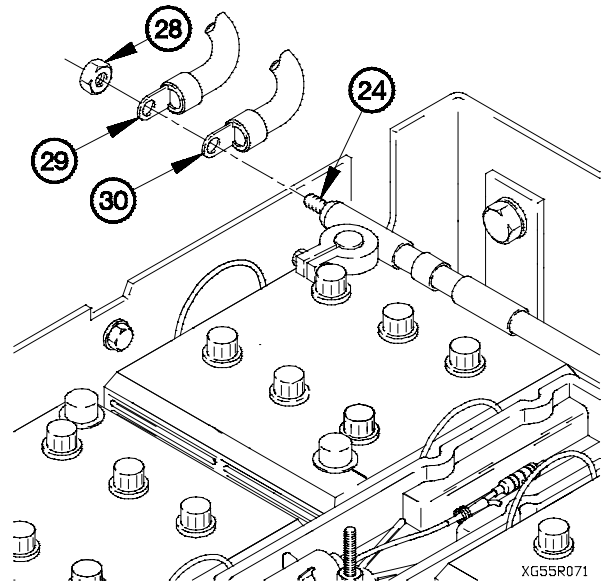

(16) Loosen two terminal screws (31) on battery 24 vdc cable (24).

(17) Remove battery 24 vdc cable (24) from battery terminals BT1 E1 (32) and BT2 E1 (33).

(17) Remove nut (34) and washer (35) from battery bracket hold down screw (36).

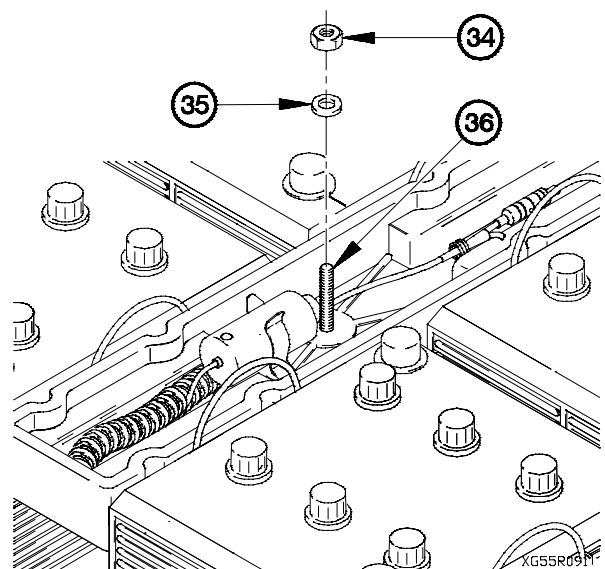

7-55. BATTERY/BATTERY CABLES REPLACEMENT (CONT)

- (18) Remove battery hold down bracket (37) from battery box (38).
- (19) Remove batteries BT3 (39), BT4 (40), BT1 (41), and BT2 (42) from battery box (38).

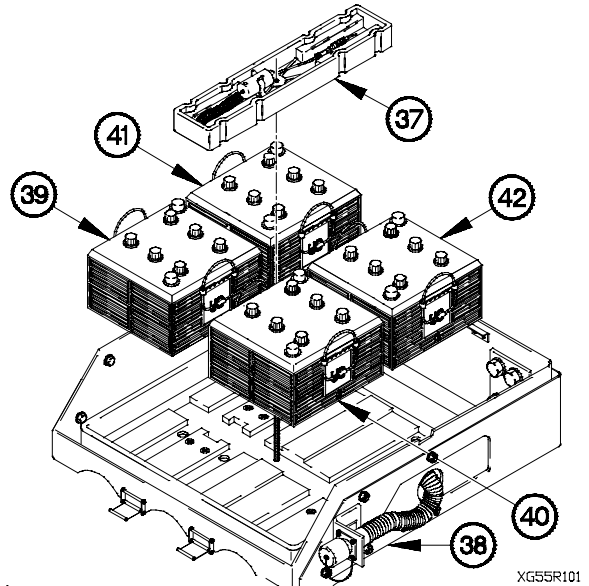

XG55R101

b. Installation

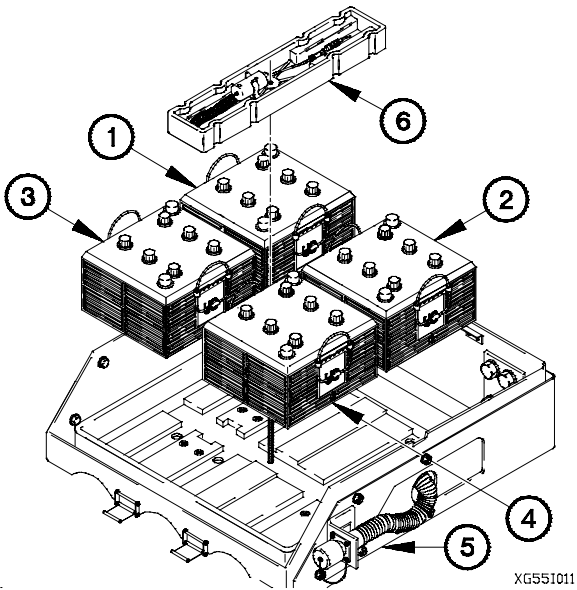

XG55I011

NOTE

Install battery terminal covers as required.

- (1) Position batteries BT1 (1), BT2 (2), BT3 (3), and BT4 (4) in battery box (5).
- (2) Position battery hold down bracket (6) in battery box (5).

- (3) Install washer (7) and nut (8) on battery bracket hold down screw (9).

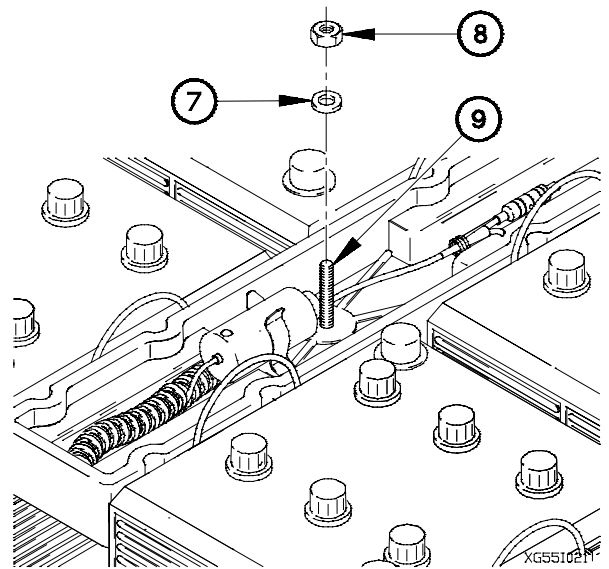

XG55I0211

- (4) Install battery 24 vdc cable (10) on battery terminals BT1 E1 (11) and BT2 E1 (12).
- (5) Tighten two terminal screws (13) on battery 24 vdc cable (10).

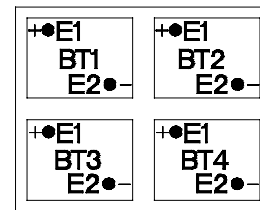

BATTERY INSTALLATION DIAGRAM

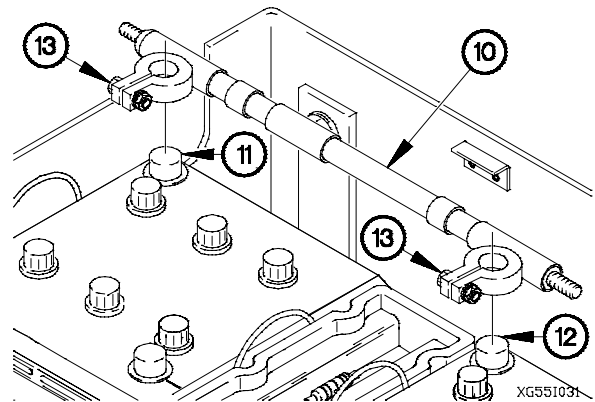

XG551031

- (6) Install terminal lugs TL10 (14), TL39 (15) on battery 24 vdc cable (10) with nut (16).

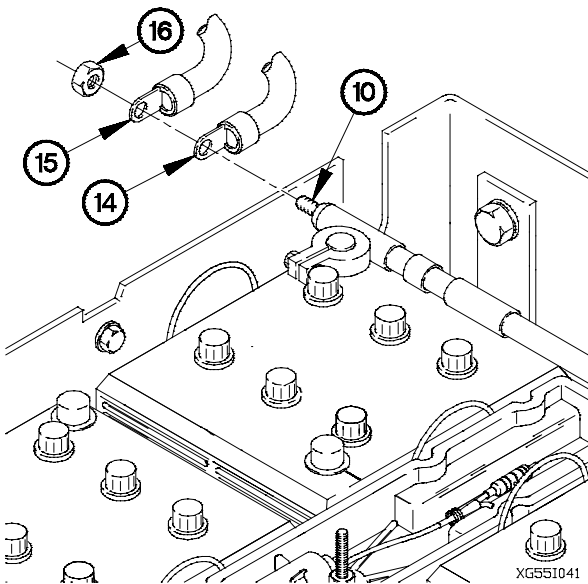

XG551041

WARNING

Negative battery terminals must be connected last. Failure to comply may result in serious injury or death to personnel.

- (7) Install battery tester terminal lug (17) and terminal lug TL49A (18) on battery 24 vdc cable (10).
- (8) Deleted.
- (9) Install nut (20) on battery 24 vdc cable (10).

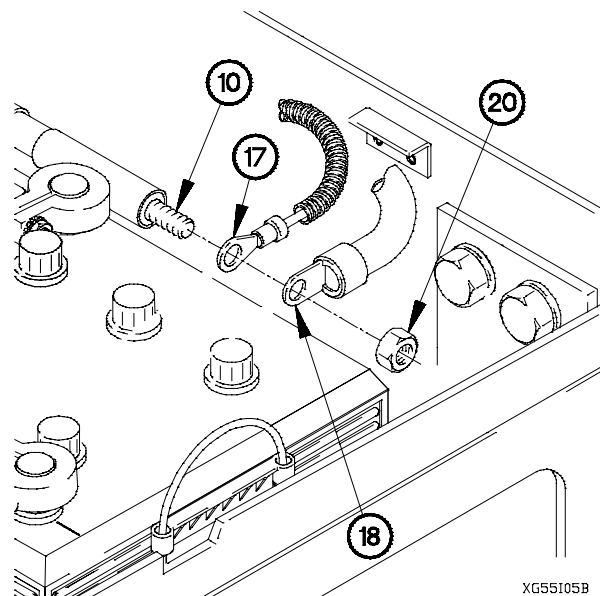

XG55105B

7-55. BATTERY/BATTERY CABLES REPLACEMENT (CONT)

- (10) Install battery BT1 to BT3 12 vdc cable (21) on battery terminals BT1 E2 (22) and BT3 E1 (23).
- (11) Tighten two terminal screws (24) on battery BT1 to BT3 12 vdc cable (21).

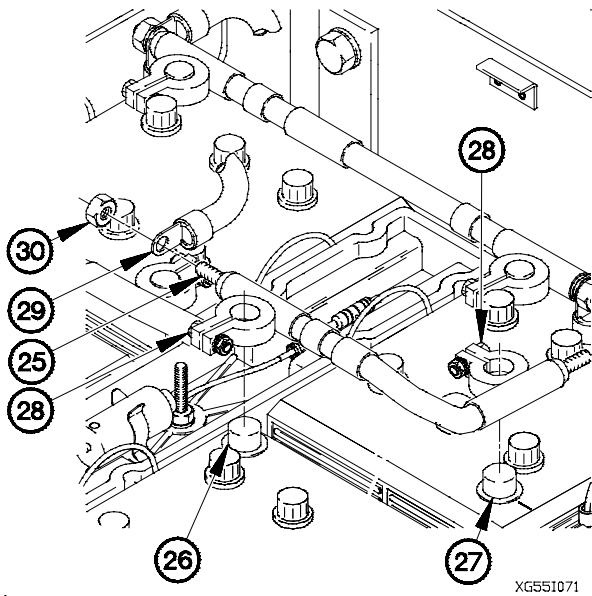
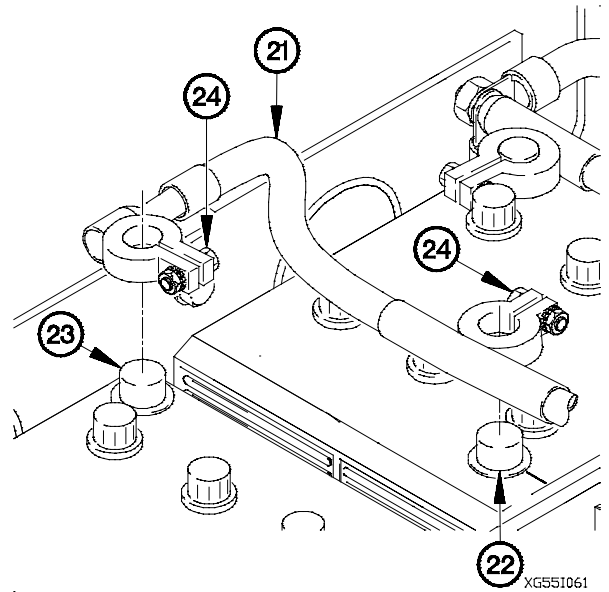

- (12) Install battery BT2 to BT4 12 vdc cable (25) on battery terminals BT4 E1 (26) and BT2 E2 (27).
- (13) Tighten two terminal screws (28) on battery BT2 to BT4 12 vdc cable (25).
- (14) Install terminal lug TL136 (29) on battery BT2 to BT4 12 vdc cable (25) with nut (30).

- (15) Install terminal lug TL99 (31) on battery BT2 to BT4 12 vdc cable (25) with nut (32).

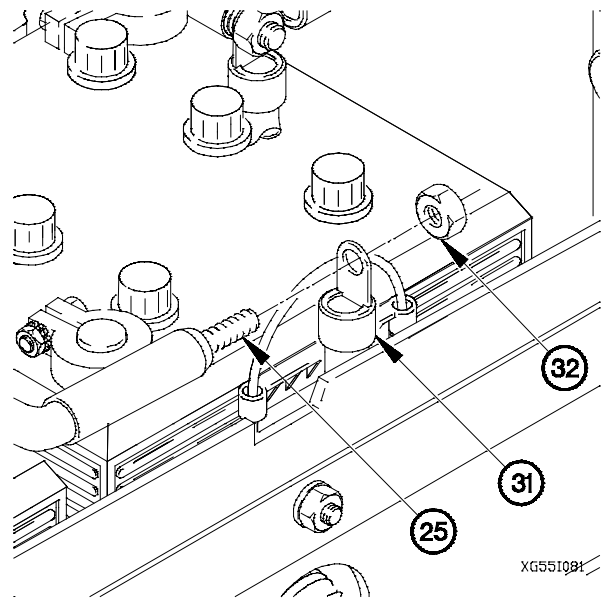

- (16) Install battery ground cable (33) on battery terminals BT4 E2 (34) and BT3 E2 (35).
- (17) Tighten two terminal screws (36) on battery ground cable (33).

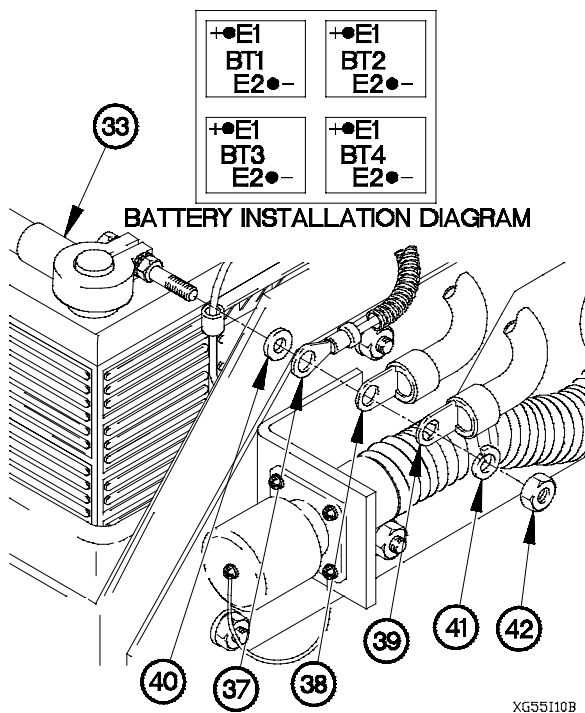
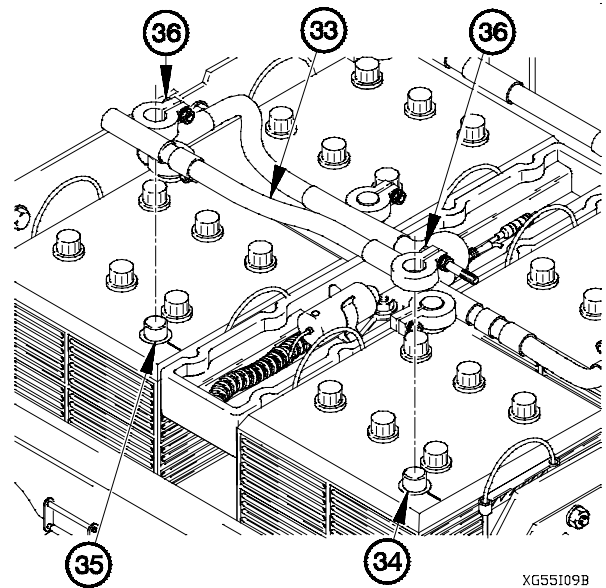

- (18) Install battery tester terminal lug (37), terminal lugs TL48 (38) and TL50A (39) and washer (40) on battery ground cable (33).
- (19) Deleted.
- (20) Install lockwasher (41) and nut (42) on battery ground cable (33).
- (21) Apply grease to all battery terminals.

c. Follow-On Maintenance.

- (1) Service batteries (TM 9-6140-200-14).
- (2) Install battery box cover (TM 9-2320-366-10-2).
- (3) Start engine (TM 9-2320-366-10-1).
- (4) Check VOLTS gage for charge indication (TM 9-2320-366-10-1).
- (5) Shut down engine (TM 9-2320-366-10-1).

End of Task.

7-56. BATTERY BOX REPLACEMENT

This task covers:

- a. Removal
- b. Installation
- c. Follow-On Maintenance

INITIAL SETUP

Equipment Conditions

- Batteries removed (para 7-55).
- NATO power cable removed (para 7-70).
- Wet tank removed (para 23-12).
- Secondary and primary air tanks removed (para 11-22).

Tools and Special Tools

- Tool Kit, Genl Mech (Item 46, Appendix C)
- Wrench, Torque, 0-175 lb-ft (Item 58, Appendix C)
- Wrench, Torque, 0-200 lb-in. (Item 59, Appendix C)
- Drill, Portable, Electric (Item 7, Appendix C)
- Drill Set, Twist (Item 6, Appendix C)
- Goggles, Industrial (Item 15, Appendix C)
- Tool Kit, Blind Rivet (Item 74, Appendix C)
- Socket Set, Socket Wrench (Item 34, Appendix C)
- Wrench Set, Socket (Item 51, Appendix C)

Tools and Special Tools (Cont)

- Wrench, Torque, 0-600 lb-ft (Item 60, Appendix C)
- Adapter, Socket Wrench (Item 1, Appendix C)
- Socket Set, Socket Wrench (Item 35, Appendix C)

Materials/Parts

- Lockwasher (2) (Item 90, Appendix G)
- Nut, Self-Locking (4) (Item 161, Appendix G)
- Washer, Flat (10) (Item 279.1, Appendix G)
- Tape, Adhesive, Rubber (Item 65.2, Appendix D)
- Rivet, Blind (Item 254.1, Appendix G)
- Rivet, Blind (Item 254.2, Appendix G)

Personnel Required

(3)

a. Removal.

- (1) Remove 16 nuts (1), screws (2), and 32 washers (3) from battery tray (4).
- (2) Remove battery tray (4) from battery box (5).
- (3) Deleted.

WARNING

Wear appropriate eye protection when removing rivets. Failure to comply may result in injury to personnel.

- (3.1) Remove six rivets (6), washers (6.1), and two latches (6.2) from battery box (5).
- (3.2) Remove six band clamps (6.3) from battery box (5).

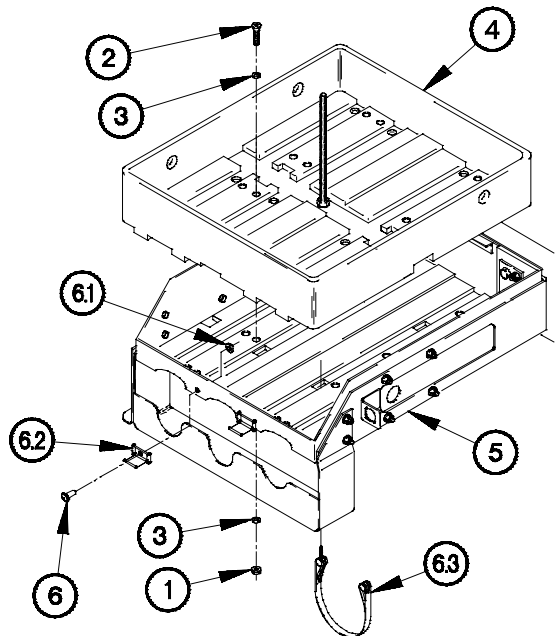

XG56R01B

- (4) Remove two nuts (7), lockwashers (8), and stud (9) from battery tray (4). Discard lockwashers.

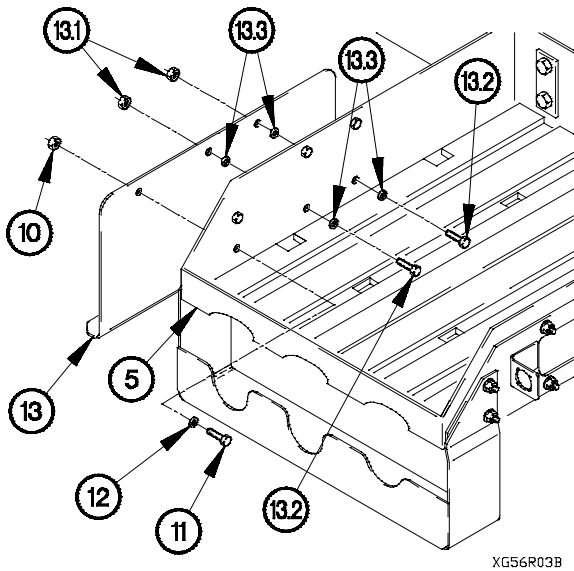
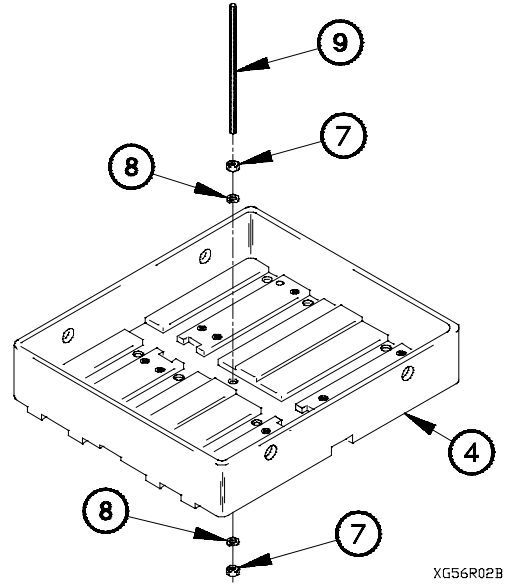

- (5) Remove nut (10), screw (11), and washer (12) from battery box (5).

- (5.1) Remove two nuts (13.1), screws (13.2), four washers (13.3), and stone guard (13) from battery box (5).

NOTE

Step (6) requires the aid of an assistant.

- (6) Remove two self-locking nuts (14) and screws (15) from battery box (5). Discard self-locking nuts.

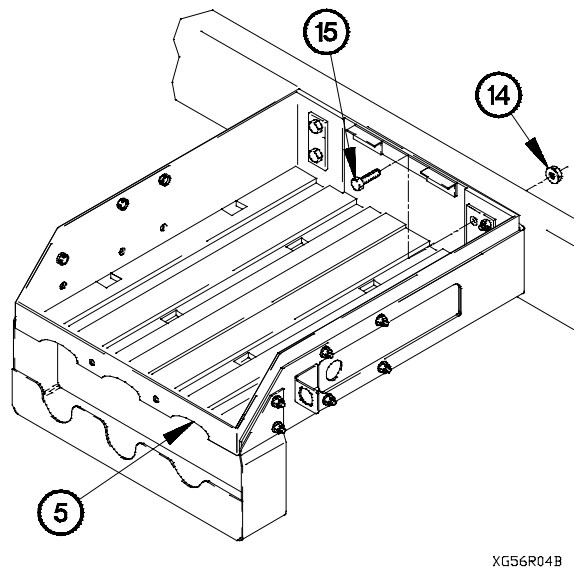

7-56. BATTERY BOX REPLACEMENT (CONT)

WARNING

Battery box weighs approximately 70 lbs (32 kgs). The aid of two assistants is required to remove battery box from vehicle frame. Failure to comply may result in injury to personnel.

NOTE

Step (7) requires the aid of two assistants.

- (7) Remove two self-locking nuts (16), screws (17), reinforcing plate (18), and battery box (5) from left frame rail (19). Discard self-locking nuts.

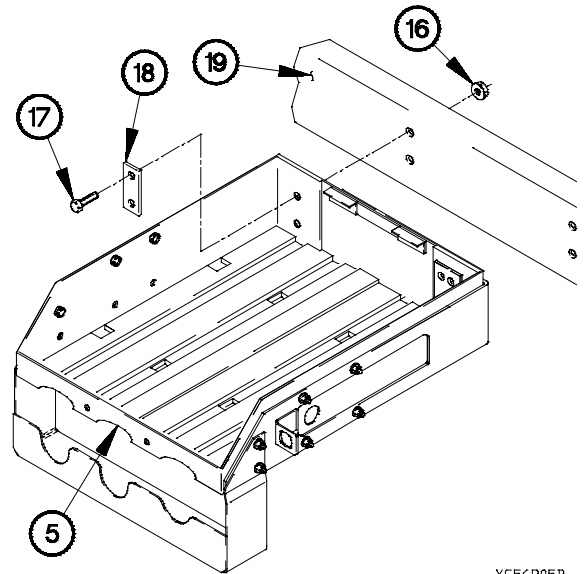

XG56R05B

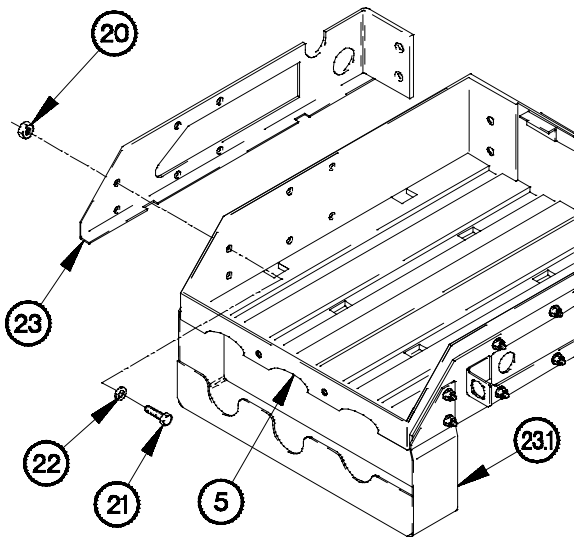

XG56R06B

- (8) Remove three nuts (20), screws (21), washers (22), and LH bracket (23) from battery box (5) and bracket (23.1).

- (9) Remove six nuts (24), screws (25), washers (26) and bracket (23.1) from battery box (5).

- (10) Deleted.

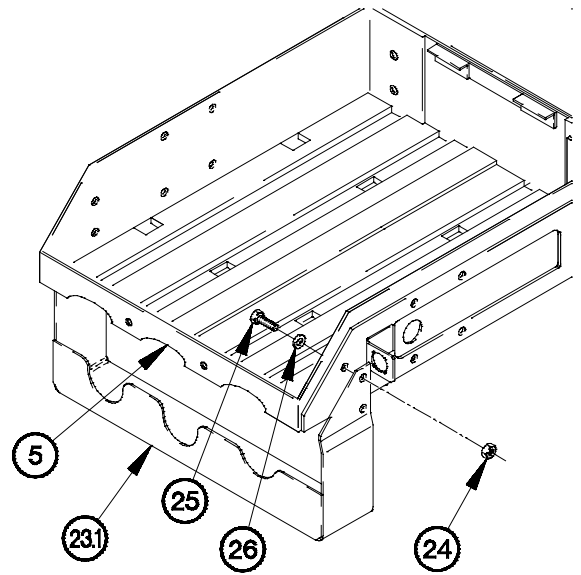

XG56R07B

- (11) Remove two nuts (30), screws (31), reinforcing plate (32), and RH bracket (33) from battery box (5).

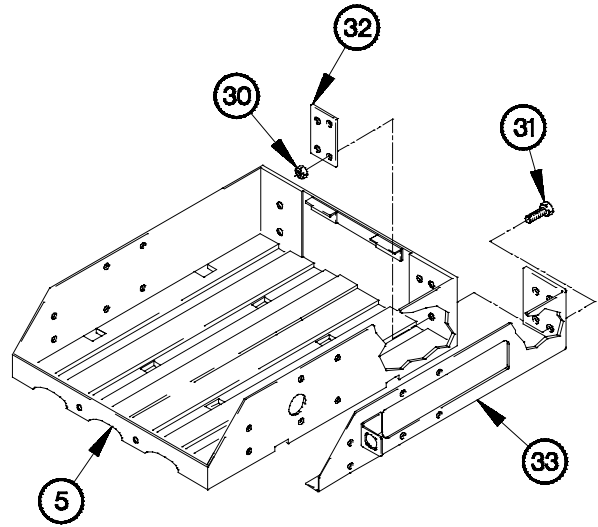

XG56R08B

WARNING

Wear appropriate eye protection when removing rivets. Failure to comply may result in injury to personnel.

- (12) Remove four rivets (34), washers (35), strip (36), and two plates (37) from battery box (5).
 (13) Remove adhesive tape (38) from strip (36).

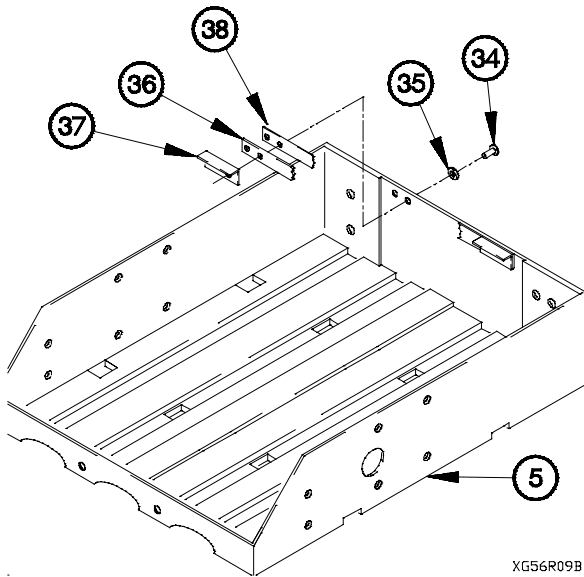

XG56R09B

b. Installation.

- (1) Cut adhesive tape (1) to 18 1/4 in. (465 mm).
 (2) Install adhesive tape (1) on strip (2).
 (3) Install two plates (3) and strips (2) on battery box (4) with four screws (6), washers (5) and nuts (6.1).

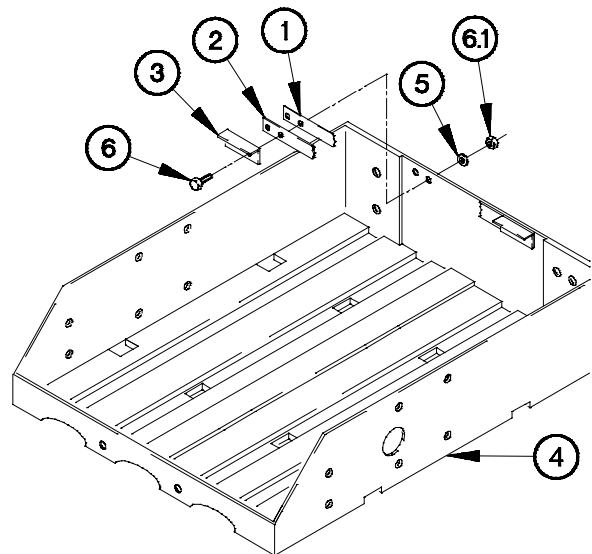

XG56I01B

7-56. BATTERY BOX REPLACEMENT (CONT)

(4) Position RH bracket (7) and reinforcing plate (8) on battery box (4) with two screws (9) and nuts (10).

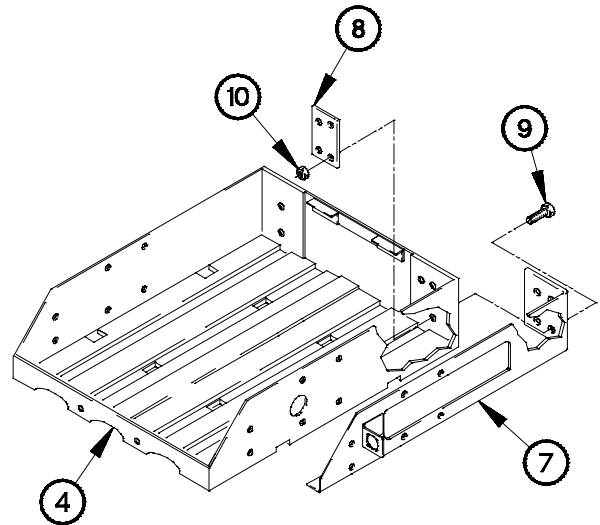

XG56102B

(5) Position bracket (10.1), six screws (11), washers (12), and nuts (13) in battery box (4).

(6) Tighten six nuts (13) to 31-39 lb-ft (42-53 N-m).

(7) Tighten two nuts (10) to 68-78 lb-ft (92-106 N-m).

(8) Deleted.

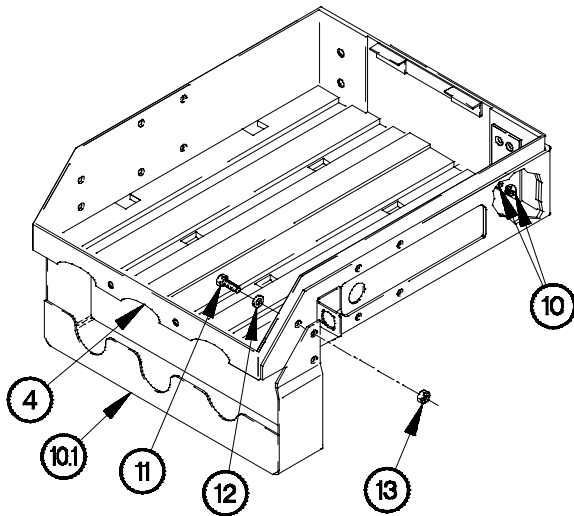

XG56103B

(9) Position bracket (10.1) and LH bracket (17) on battery box (4) with three screws (18), washers (19), and nuts (20).

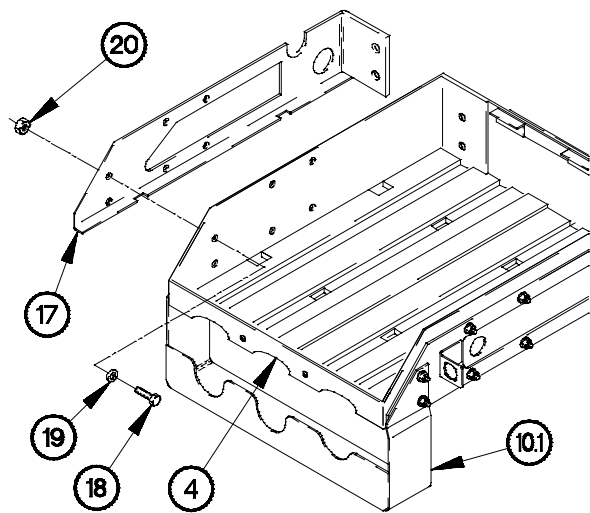

XG56104B

WARNING

Battery box weighs approximately 70 lbs (32 kgs). The aid of two assistants is required to position battery box on vehicle frame. Failure to comply may result in injury to personnel.

NOTE

Step (10) requires the aid of two assistants.

- (10) Position battery box (4), and reinforcing plate (21) on left frame rail (22) with two screws (23) and self-locking nuts (24).

- (11) Deleted.

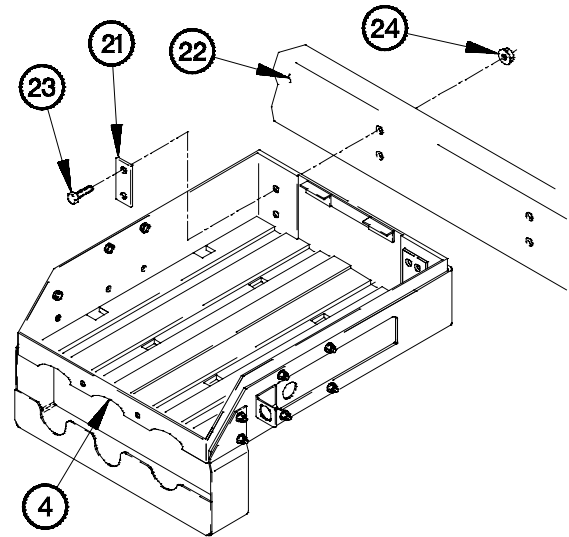

XG56105B

NOTE

Steps (12) and (13) require the aid of an assistant.

- (12) Position two screws (27) and self-locking nuts (28) in battery box (4).
- (13) Tighten screws (23 and 27) to 171-209 lb-ft (232-283 N-m).

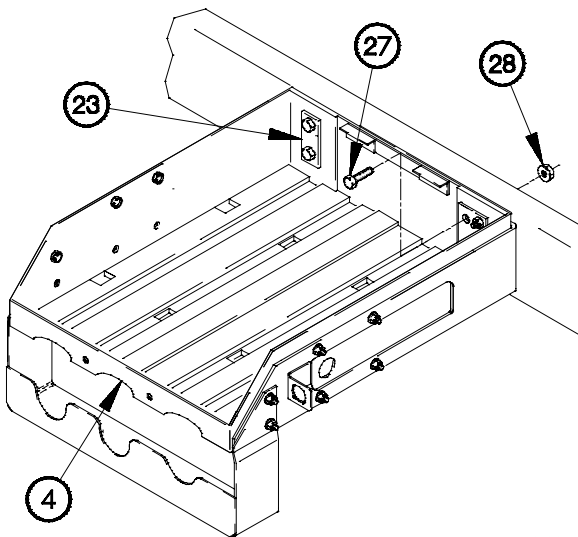

XG56106B

- (14) Position stone guard (29) on battery box (4) with screw (30), washer (31), and nut (32).
- (14.1) Position two screws (32.1), four washers (32.2), and two nuts (32.3) in stone guard (29).
- (15) Tighten nuts (32, 32.3 and 20) to 31-39 lb-ft (42-53 N-m).

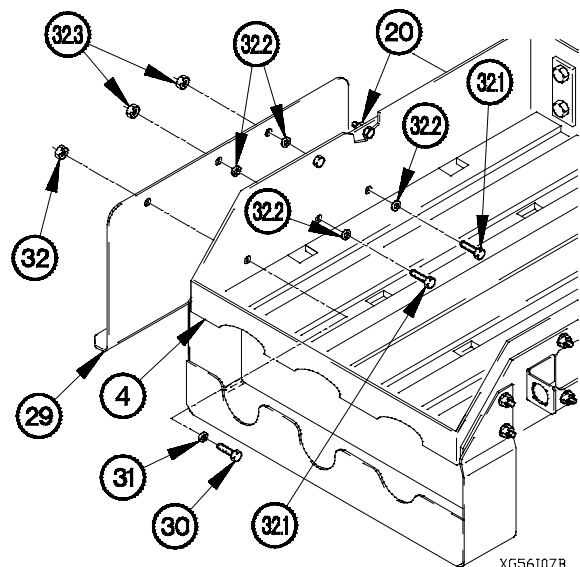

XG56107B

7-56. BATTERY BOX REPLACEMENT (CONT)

- (16) Position stud (33) in battery tray (34) with two lockwashers (35) and nuts (36).
- (17) Tighten two nuts (36) to 81-99 lb-in. (9-11 N-m).

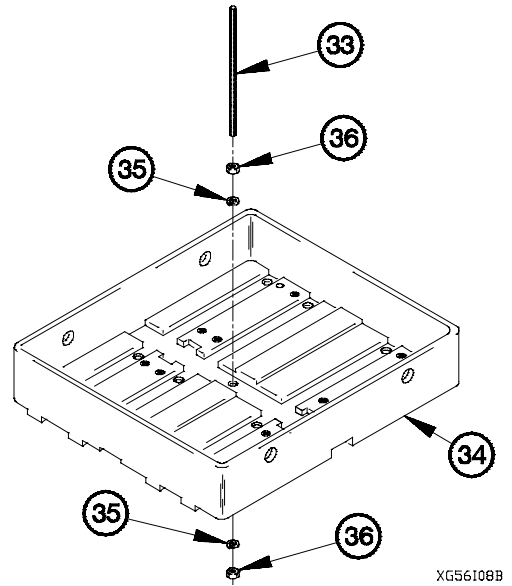

XG56108B

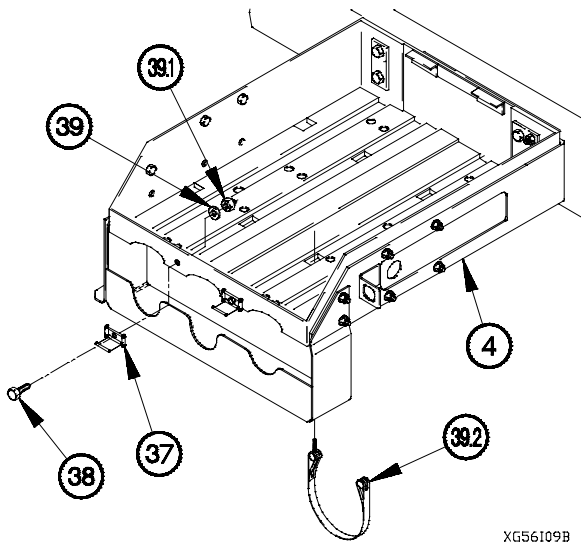

XG56109B

- (18) Install two latches (37) on battery box (4) with six screws (38), lockwashers (39) and nuts (39.1).
- (19) Install six band clamps (39.2) in battery box (4).

- (20) Position battery tray (34) in battery box (4).
- (21) Position 32 washers (40), 16 screws (41) and self-locking nuts (42) in battery tray (34).
- (22) Tighten 16 nuts (42) to 9-11 lb-ft (12-15 N-m).

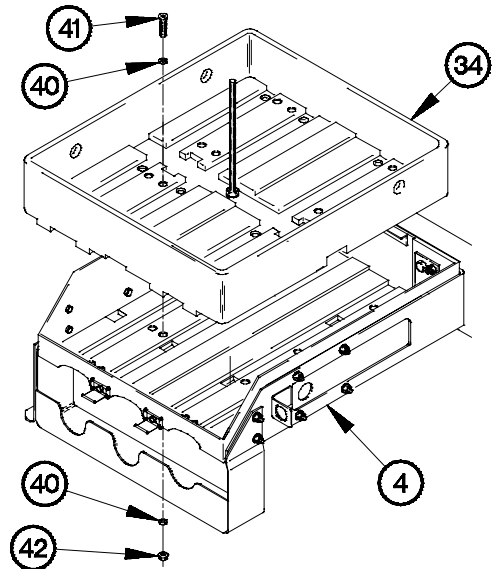

XG56110B

c. Follow-On Maintenance.

- (1) Deleted.
- (2) Deleted.
- (3) Install secondary and primary air tanks (para 11-22).
- (4) Install wet tank (para 23-12).
- (5) Install NATO power cable (para 7-70).
- (6) Install batteries (para 7-55).
- (7) Start engine (TM 9-2320-366-10-1).
- (8) Check VOLTS gage for charge indication (TM 9-2320-366-10-1).
- (9) Shut down engine (TM 9-2320-366-10-1).

End of Task.

7-57. DISCONNECTING/CONNECTING BATTERIES	
This task covers:	
a. Disconnecting b. Connecting	c. Follow-On Maintenance
INITIAL SETUP	
Equipment Conditions Engine shut down (TM 9-2320-366-10-1). Battery box cover removed (TM 9-2320-366-10-2).	Tools and Special Tools (Cont) Tool Kit, Genl Mech (Item 46, Appendix C)
Tools and Special Tools Goggles, Industrial (Item 15, Appendix C) Apron, Rubber (Item 3, Appendix C) Gloves, Rubber (Item 13, Appendix C) Puller, Battery Terminal (Item 28, Appendix C)	Materials/Parts Dispenser, Pressure Sensitive Adhesive Tape (Item 20, Appendix D) Grease, Automotive and Artillery (GAA) (Item 22, Appendix D) Lockwasher (Item 87, Appendix G)

a. Disconnecting.



- Remove rings, bracelets, watches, necklaces, and any other jewelry before working around vehicle. Jewelry can catch on equipment and cause injury or short across electrical circuit and cause severe burns or electrical shock. Batteries can explode from a spark. Battery acid is harmful to skin and eyes. Always wear eye protection when working with batteries. Failure to comply may result in injury to personnel.
- Negative battery terminals and battery tester negative terminal lug must be disconnected first. Failure to comply may result in serious injury or death to personnel.

NOTE

Tag battery terminals, terminal lugs, and connection points prior to disconnecting.

- (1) Remove nut (1) and lockwasher (2) from battery 24 VDC ground cable (3). Discard lockwasher.
- (2) Deleted.
- (3) Remove terminal lugs TL50A (5), TL48 (6), battery tester terminal lug (7) and washer (8) from battery 24 VDC ground cable (3).

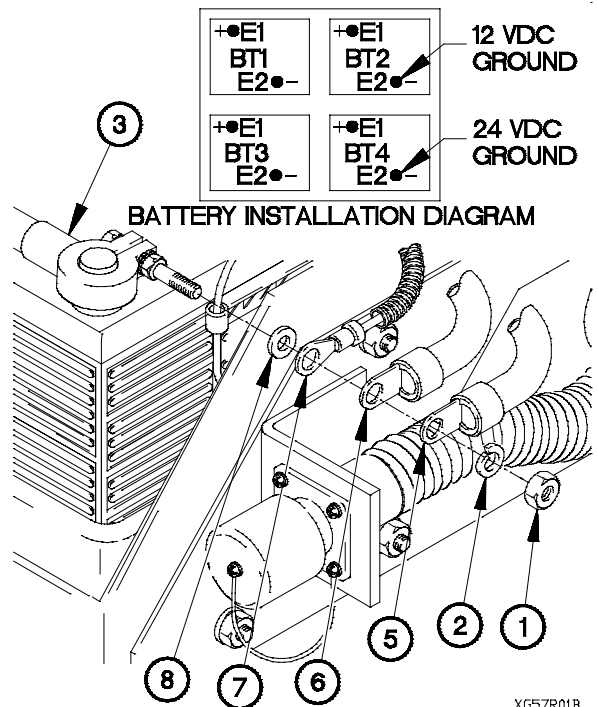

XG57R01B

- (4) Remove nut (9) and terminal lug TL99 (10) from battery 12 VDC cable (11).

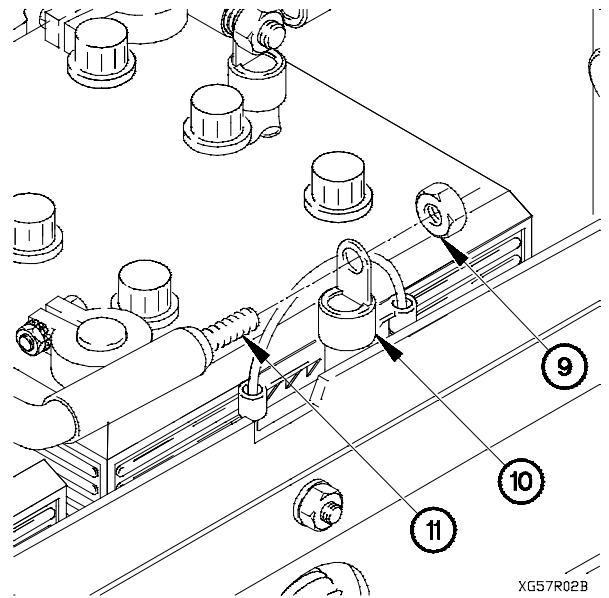

b. Connecting.

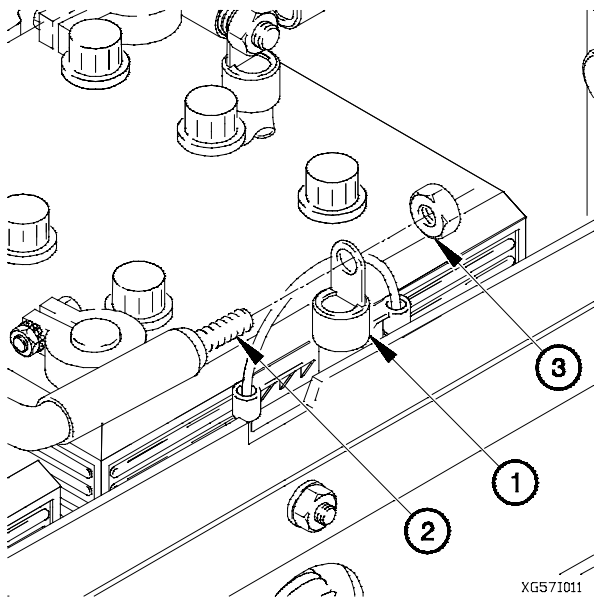

WARNING

Negative battery terminals must be connected last. Failure to comply may result in serious injury or death to personnel.

- (1) Install terminal lug TL99 (1) on battery 12 VDC cable (2) with nut (3).

- (2) Install washer (4) battery tester terminal lug (5), and terminal lugs TL48 (6) and TL50A (7) on battery 24 VDC ground cable (8).

(3) Deleted.

- (4) Install lockwasher (10) and nut (11) on battery 24 VDC ground cable (8).

(5) Apply grease to all battery terminals.

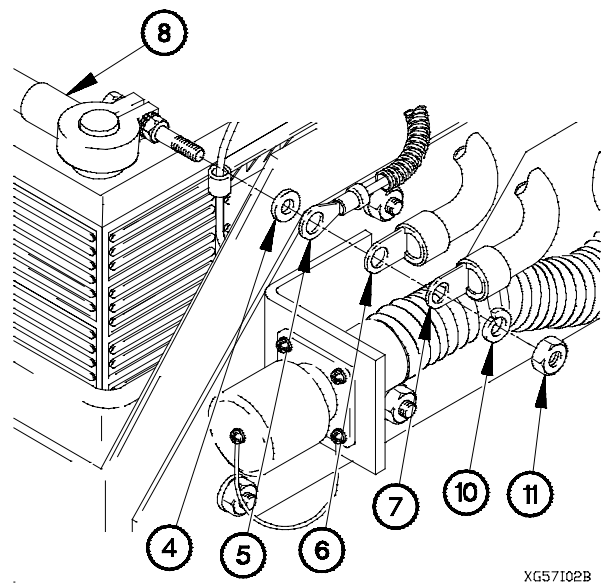

7-57. DISCONNECTING/CONNECTING BATTERIES (CONT)
--

c. Follow-On Maintenance.

- (1) Install battery box cover (TM 9-2320-366-10-2).
- (2) Start engine (TM 9-2320-366-10-1).
- (3) Check VOLTS gage for charge indication (TM 9-2320-366-10-1).
- (4) Shut down engine (TM 9-2320-366-10-1).

End of Task.

7-58. AUXILIARY PANEL CABLE ASSEMBLY REPLACEMENT

This task covers:

- a. Removal
- b. Installation
- c. Follow-On Maintenance

INITIAL SETUP

Equipment Conditions

Personnel heater removed (para 18-9).

Tools and Special Tools

Tool Kit, Genl Mech (Item 46, Appendix C)

Materials/Parts

Dispenser, Pressure Sensitive Adhesive Tape (Item 20, Appendix D)

Ties, Cable, Plastic (Item 69, Appendix D)

a. Removal.

NOTE

- Remove plastic cable ties as required.
- Tag wires and connection points prior to disconnecting.

- (1) Disconnect connector J108 (1) from connector P108 (2).
- (2) Disconnect connector J210 (3) from connector P210 (4).

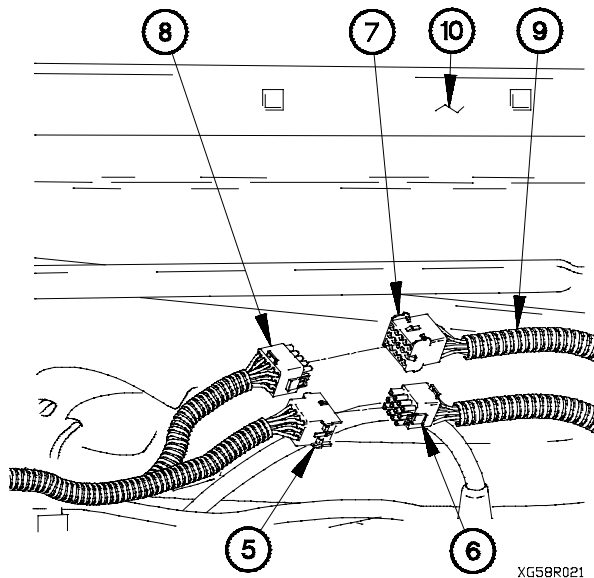
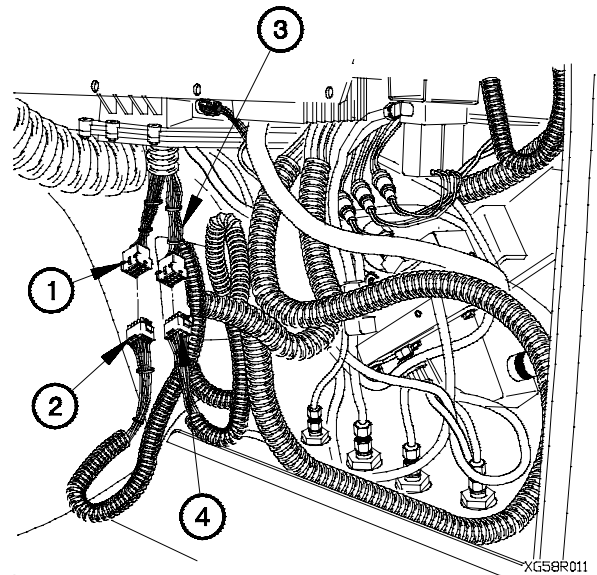

- (3) Disconnect connector P913 (5) from connector J913 (6).
- (4) Disconnect connector P912 (7) from connector J912 (8).
- (5) Remove auxiliary panel cable assembly (9) from dashboard (10).

7-58. AUXILIARY PANEL CABLE ASSEMBLY REPLACEMENT (CONT)

b. Installation.

- (1) Position auxiliary panel cable assembly (1) in dashboard (2).
- (2) Connect connector P913 (3) to connector J913 (4).
- (3) Connect connector P912 (5) to connector J912 (6).

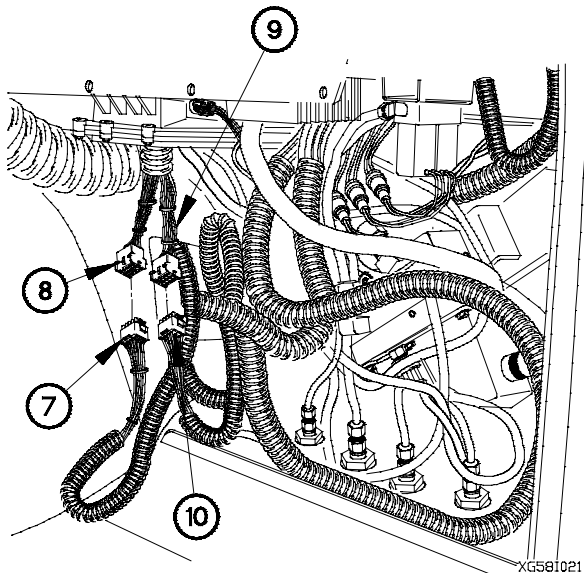
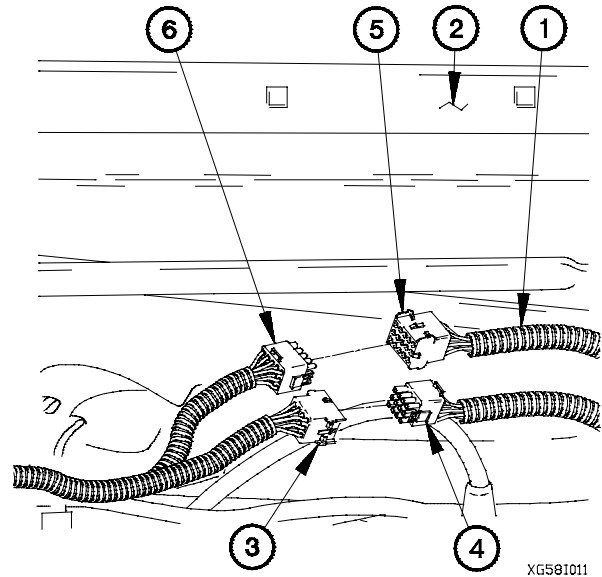

NOTE

Install plastic cable ties as required.

- (4) Connect connector P108 (7) to connector J108 (8).
- (5) Connect connector P210 (9) to connector J210 (10).

c. Follow-On Maintenance.

- (1) Install personnel heater (para 18-9).
- (2) Check rocker switches and tachometer operation (TM 9-2320-366-10-1).

End of Task.

7-59. CHEMICAL ALARM KIT CABLE ASSEMBLY REPLACEMENT

This task covers:

- a. Removal
- b. Installation
- c. Follow-On Maintenance

INITIAL SETUP

Equipment Conditions

- Batteries disconnected (para 7-57).
- Kick panel removed (para 16-3).

Materials/Parts

- Ties, Cable, Plastic (Item 69, Appendix D)

Tools and Special Tools

- Tool Kit, Genl Mech (Item 46, Appendix C)

a. Removal.

NOTE

- Note routing of chemical alarm kit cable prior to removal.
- Remove plastic cable ties as required.

- (1) Disconnect connector J99 (1) from connector P99 (2).
- (2) Remove chemical alarm kit cable assembly (3) from vehicle.

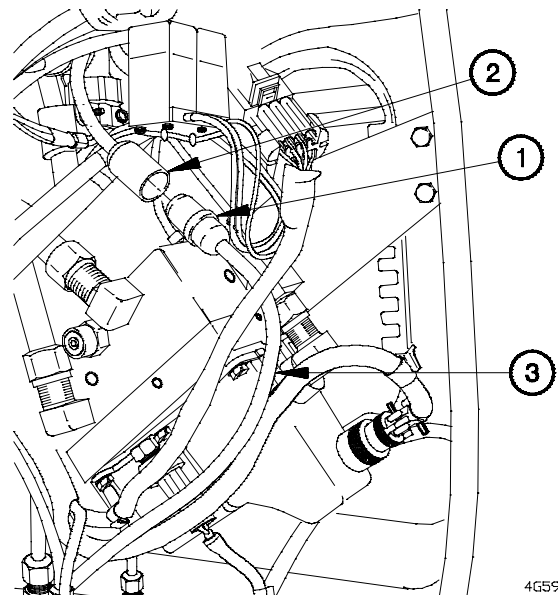

4G59X011

b. Installation.

NOTE

Install plastic cable ties as required.

Connect connector P99 (2) to connector J99 (1) and route chemical alarm kit cable assembly (3).

c. Follow-On Maintenance.

- (1) Install kick panel (para 16-3).
- (2) Connect batteries (para 7-57).

End of Task.

7-60. CENTRAL TIRE INFLATION SYSTEM (CTIS) CABLE ASSEMBLY REPLACEMENT	
This task covers:	
a. Removal b. Installation	c. Follow-On Maintenance
INITIAL SETUP	
Equipment Conditions Batteries disconnected (para 7-57). Kick panel removed (para 16-3). Personnel heater removed (para 18-9).	Materials/Parts Ties, Cable, Plastic (Item 69, Appendix D)
Tools and Special Tools Tool Kit, Genl Mech (Item 46, Appendix C) Wrench, Torque, 0-175 lb-ft (Item 58, Appendix C)	

a. Removal.

NOTE

- Note routing of CTIS cable assembly prior to removal.
- Remove plastic cable ties as required.

- (1) Disconnect connector P111 (1) from connector J111 (2).
- (2) Disconnect connector P112 (3) from manifold valve assembly (4).
- (3) Disconnect connector P113 (5) from pressure transducer (6).
- (4) Remove CTIS cable assembly (7) from vehicle.

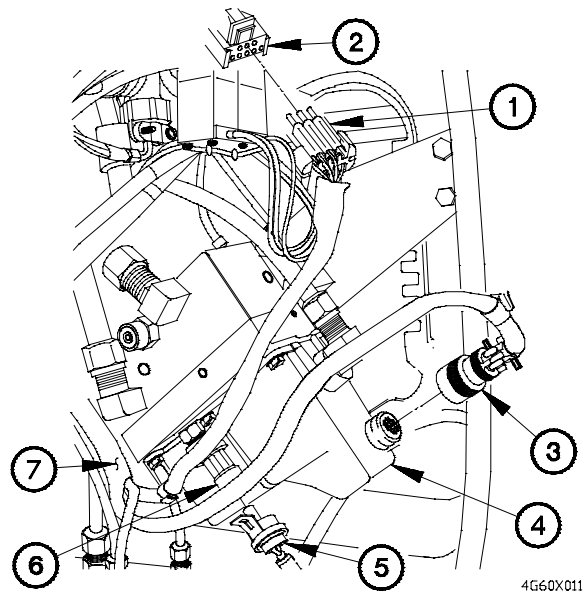

b. Installation.

NOTE

Install plastic cable ties as required.

- (1) Position CTIS cable assembly (7) in vehicle.
- (2) Connect connector P113 (5) to pressure transducer (6).
- (3) Connect connector P112 (3) to manifold valve assembly (4).
- (4) Connect connector P111 (1) to connector J111 (2).

c. Follow-On Maintenance.

- (1) Install personnel heater (para 18-9).
- (2) Install kick panel (para 16-3).
- (3) Connect batteries (para 7-57).
- (4) Start engine (TM 9-2320-366-10-1).
- (5) Operate vehicle and check CTIS system for proper operation (TM 9-2320-366-10-1).
- (6) Shut down engine (TM 9-2320-366-10-1).

End of Task.

7-61. LEFT-HAND DOOR AND CAB MARKER LIGHTS CABLE ASSEMBLY REPLACEMENT

This task covers:

- a. Removal
- b. Installation
- c. Follow-On Maintenance

INITIAL SETUP

Equipment Conditions

- Batteries disconnected (para 7-57).
- PDP cover removed (para 16-2).

Tools and Special Tools

- Tool Kit, Genl Mech (Item 46, Appendix C)

Materials/Parts

- Ties, Cable, Plastic (Item 69, Appendix D)
- Lockwasher (4) (Item 82, Appendix G)
- Lockwasher (2) (Item 88, Appendix G)
- Gasket (2) (Item 24, Appendix G)

a. Removal.

NOTE

- Note routing of left-hand door and cab marker lights cable assembly prior to removal.
- Remove plastic cable ties as required.

- (1) Remove three screws (1) and washers (2) from PDP (3).
- (2) Remove three screws (4) from PDP (3).
- (3) Lift PDP (3) outward to gain access.

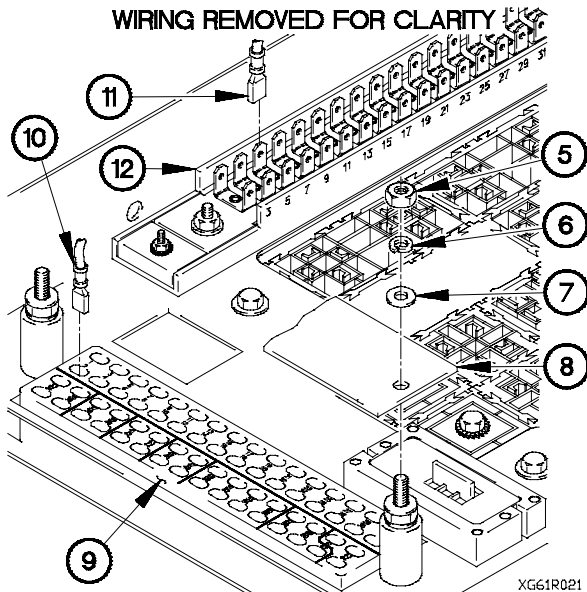
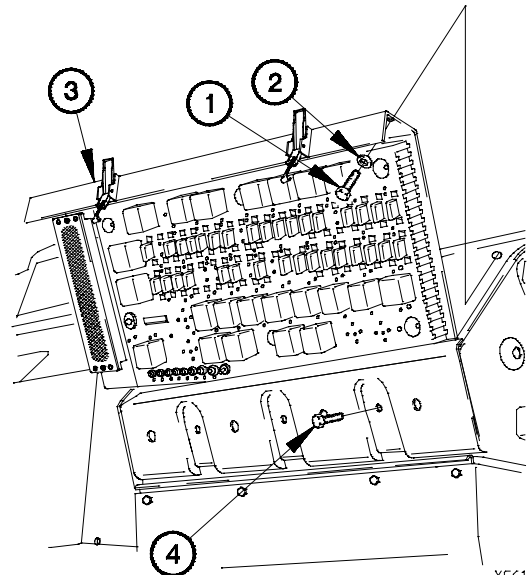

- (4) Remove two nuts (5), lockwashers (6), washers (7), and cover (8) from terminal board TB1 (9). Discard lockwashers.
- (5) Disconnect terminal lug TL75 (10) from terminal board TB1 (9) position 2.
- (6) Disconnect terminal lug TL87 (11) from terminal board TB2 (12) position 6.

- (7) Remove two screws (13) and marker lens cover (14) from marker light (15).

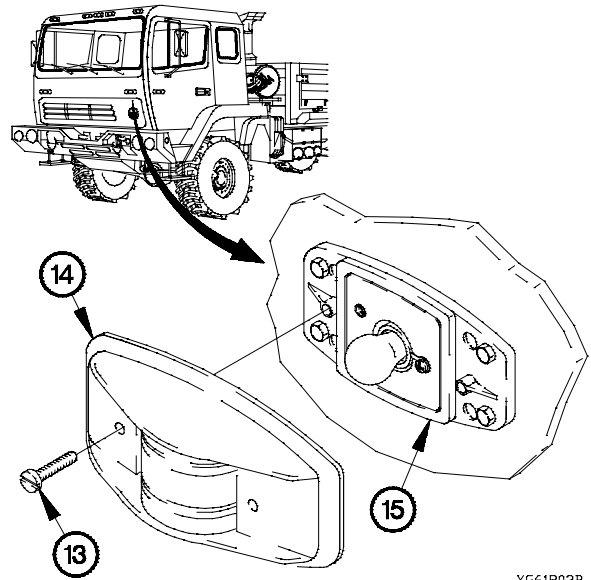

XG61R03B

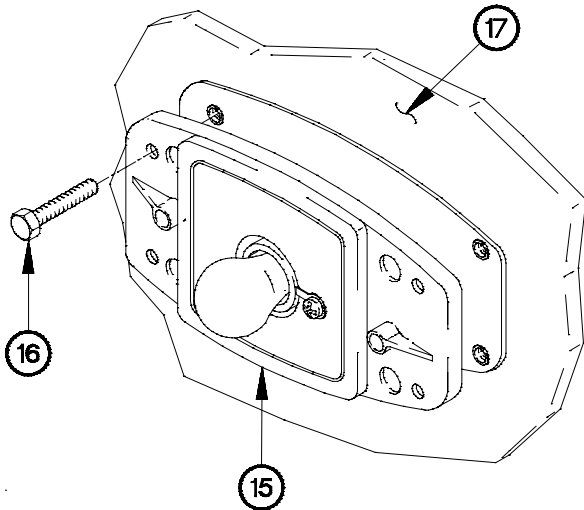

XG61R041

- (8) Remove four screws (16) and marker light (15) from cab (17).

- (9) Remove nut (18), lockwasher (19), terminal lug TL133 (20), and lockwasher (21) from marker light (15). Discard lockwashers.
- (10) Disconnect connector P129 (22) from marker light connector 489 (23).
- (11) Remove gasket (24) from marker light (15). Discard gasket.

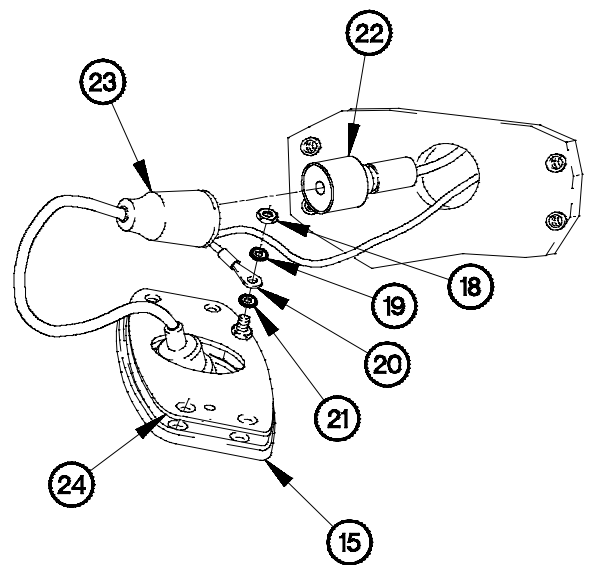

XG61R05B

7-61. LEFT-HAND DOOR AND CAB MARKER LIGHTS CABLE ASSEMBLY REPLACEMENT (CONT)

(12) Remove two screws (25) and marker lens cover (26) from marker light (27).

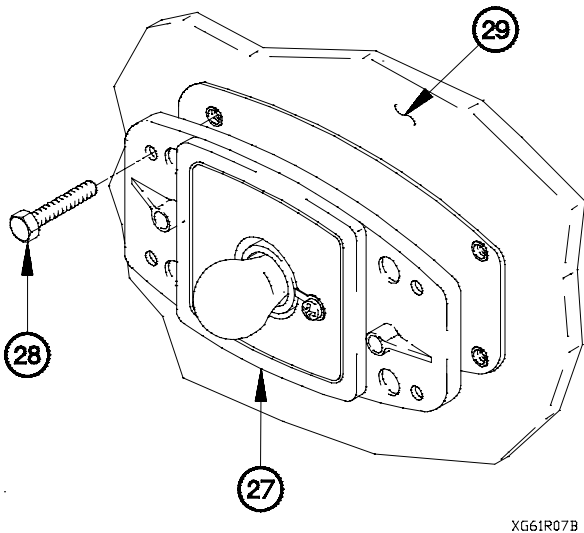
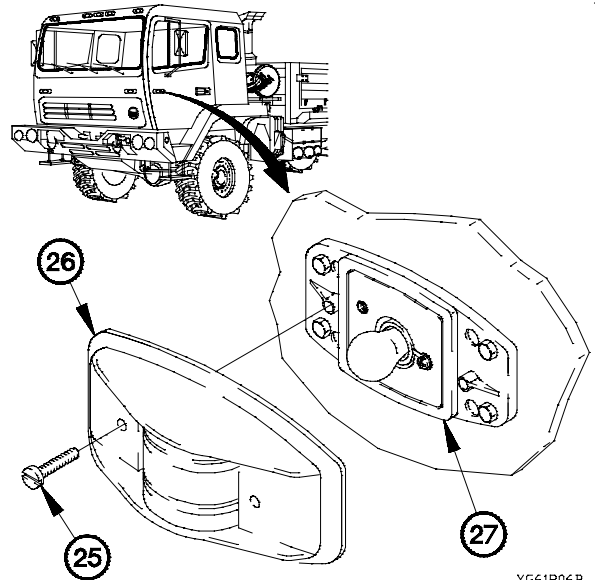

(13) Remove four screws (28) and marker light (27) from door (29).

(14) Remove nut (30), lockwasher (31), and terminal lug TL130 (32), and lockwasher (33) from marker light (27). Discard lockwashers.

(15) Disconnect connector P130 (34) from marker light connector 489 (35).

(16) Remove gasket (36) from marker light (27). Discard gasket.

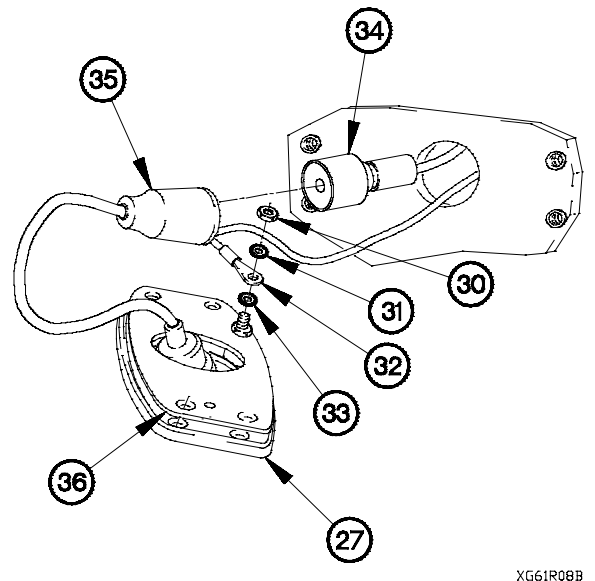

- (17) Remove tube protector (37) and left-hand door and cab marker lights cable assembly (38) from door (29).
- (18) Remove left-hand door and cab marker lights cable assembly (38) from dashboard (39).

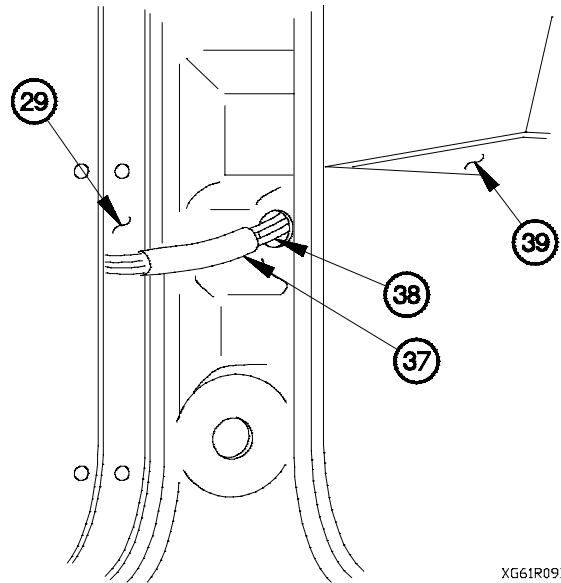

XG61R09B

b. Installation.

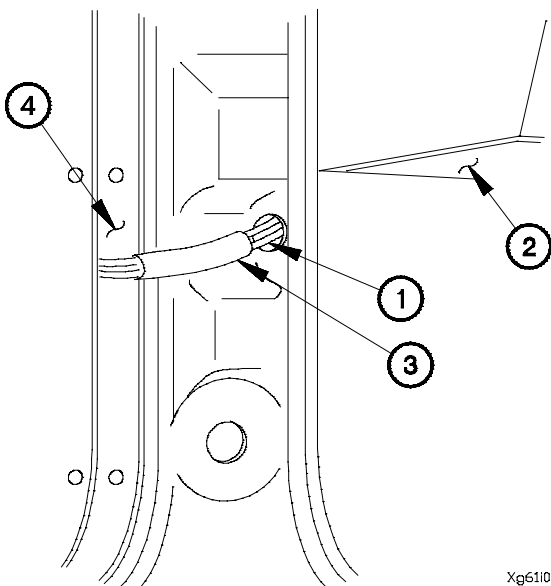

Xg61I011

NOTE

Install plastic cable ties as required.

- (1) Position left-hand door and cab marker lights cable assembly (1) in dashboard (2).
- (2) Install left-hand door and cab marker lights cable assembly (1) and tube protector (3) in door (4).

- (3) Install gasket (5) on marker light (6).
- (4) Connect connector P130 (7) to marker light connector 489 (8).
- (5) Install lockwasher (8.1) and terminal lug TL130 (9) on marker light (6) with lockwasher (10) and nut (11).

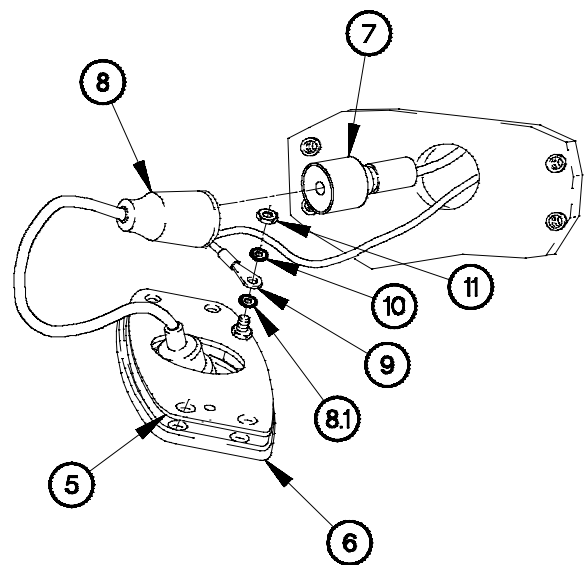

XG61I02B

7-61. LEFT-HAND DOOR AND CAB MARKER LIGHTS CABLE ASSEMBLY REPLACEMENT (CONT)

(6) Install marker light (6) on door (4) with four screws (12).

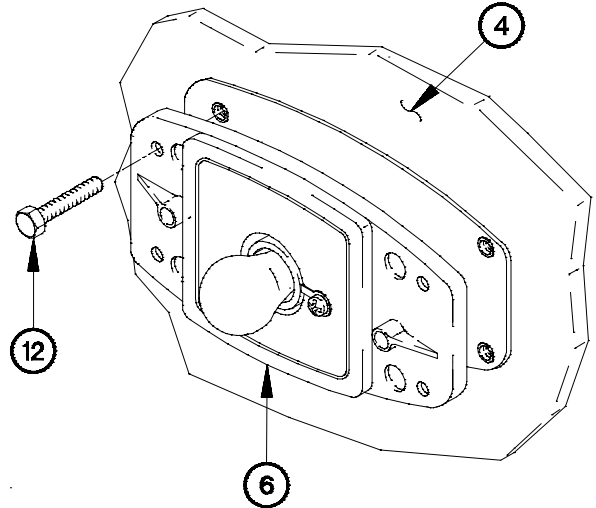

XG61103B

(7) Install marker lens cover (13) on marker light (6) with two screws (14).

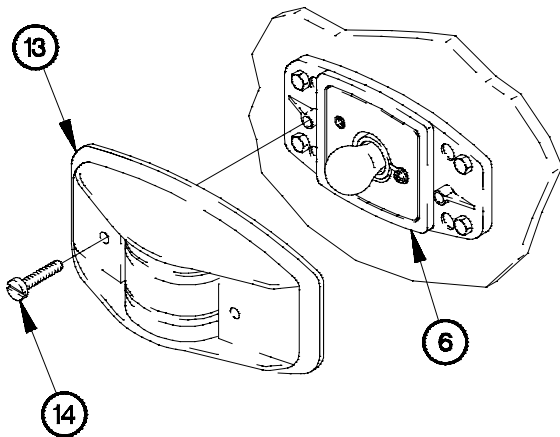

XG61104B

(8) Install gasket (15) on marker light (16).

(9) Connect connector P129 (17) to marker light connector 489 (18).

(10) Install lockwasher (18.1) and terminal lug TL133 (19) on marker light (16) with lockwasher (20) and nut (21).

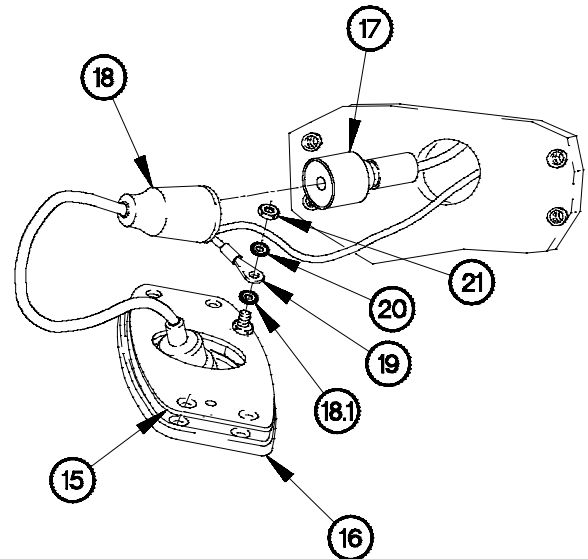

XG61105B

(11) Install marker light (16) on cab (22) with four screws (23).

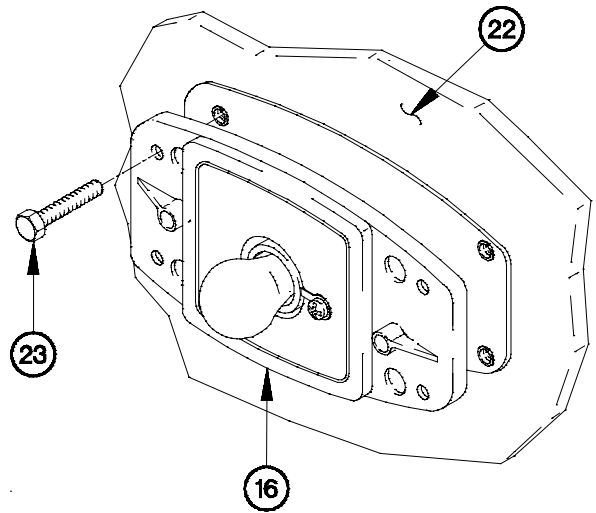

xa611061.dwg

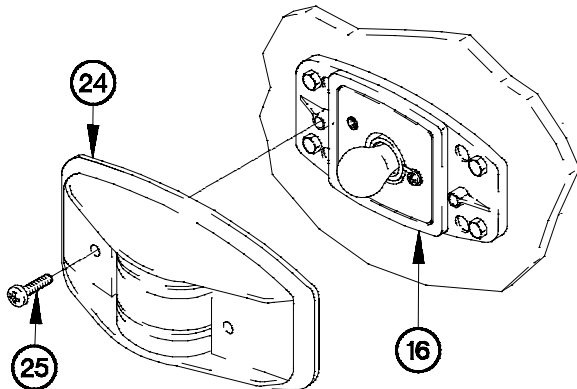

xa611071.dwg

(12) Install marker lens cover (24) on marker light (16) with two screws (25).

(13) Connect terminal lug TL87 (26) to terminal board TB2 (27) position 6.

(14) Connect terminal lug TL75 (28) to terminal board TB1 (29) position 2.

(15) Install cover (30) on terminal board TB1 (29) with two washers (31), lockwashers (32), and nuts (33).

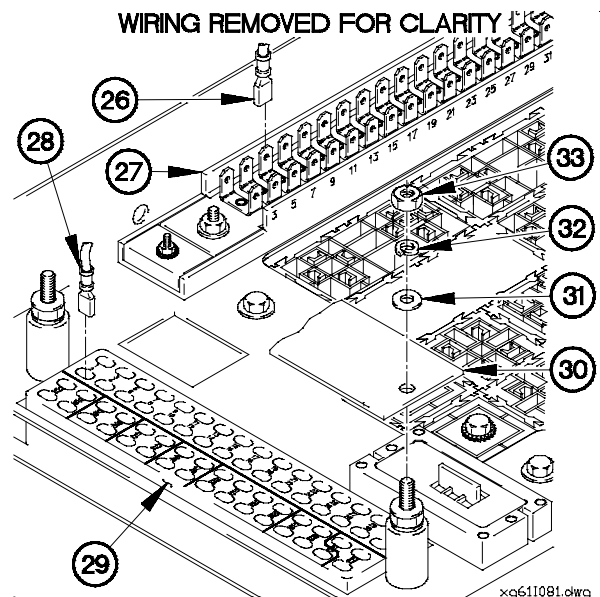

xa611081.dwg

**7-61. LEFT-HAND DOOR AND CAB MARKER LIGHTS CABLE ASSEMBLY
REPLACEMENT (CONT)**

- (16) Install PDP (34) on dashboard (2) with three screws (35).
- (17) Install three washers (36) and screws (37) in PDP (34).

c. Follow-On Maintenance.

- (1) Install PDP cover (para 16-2).
- (2) Connect batteries (para 7-57).
- (3) Check operation of left-hand door and cab marker lights (TM 9-2320-366-10-1).

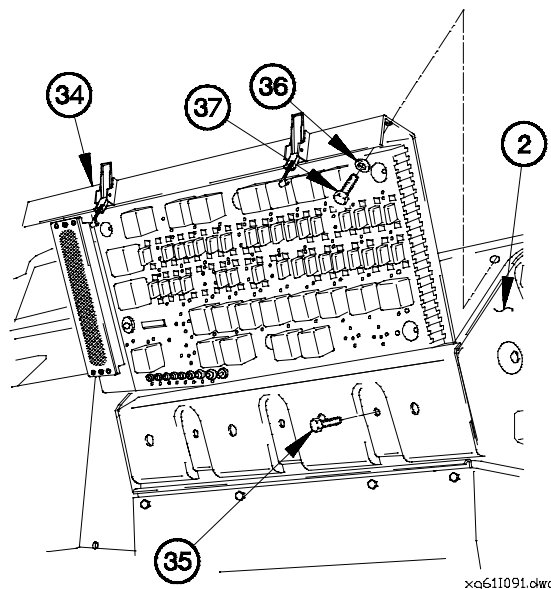

End of Task.

7-62. M1093/M1094 CAB CLEARANCE AND MARKER LIGHTS LOWER CABLE ASSEMBLY REPLACEMENT

This task covers:

- a. Removal
- b. Installation
- c. Follow-On Maintenance

INITIAL SETUP

Equipment Conditions

- Batteries disconnected (para 7-57).
- PDP cover removed (para 16-2).

Tools and Special Tools

- Tool Kit, Genl Mech (Item 46, Appendix C)
- Wrench, Torque, 0-75 lb-in. (Item 90, Appendix B)

Material/Parts

- Dispenser, Pressure Sensitive Adhesive Tape (Item 20, Appendix D)
- Lockwasher (2) (Item 88, Appendix G)

a. Removal.

- (1) Remove three screws (1) and washers (2) from PDP (3).
- (2) Remove three screws (4) from PDP (3).
- (3) Lift PDP (3) outward to gain access.

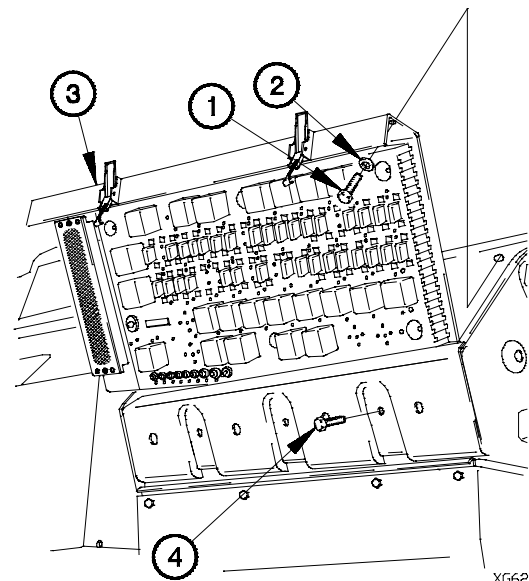

NOTE

Tag wires and connection points prior to disconnecting.

- (4) Remove two nuts (5), lockwashers (6), washers (7), and cover (8) from terminal board TB1 (9). Discard lockwashers.
- (5) Disconnect terminal lug TL74 (10) from terminal board TB1 (9) position 3.
- (6) Disconnect terminal lug TL86 (11) from terminal board TB2 (12) position 4.

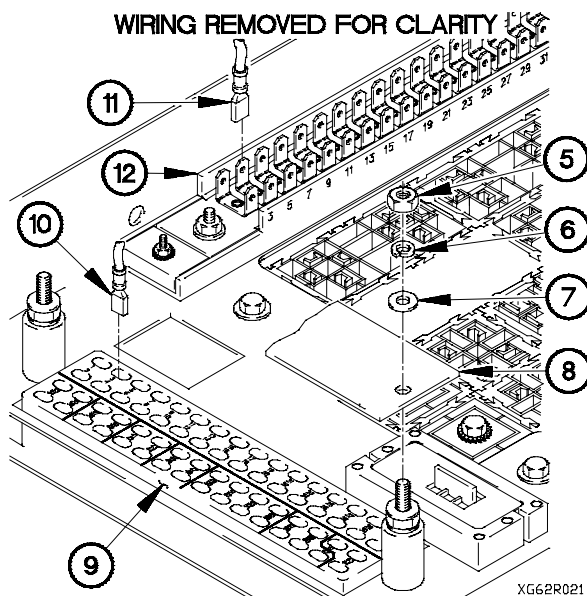

7-62. M1093/M1094 CAB CLEARANCE AND MARKER LIGHTS LOWER CABLE ASSEMBLY REPLACEMENT (CONT)

- (7) Disconnect connector P3 (13) from connector J3 (14).
- (8) Remove two screws (15), washers (16), clamps (17), and M1093/M1094 cab clearance and marker lights lower cable assembly (18) from cab (19).
- (9) Remove two clamps (17) from M1093/M1094 cab clearance and marker lights lower cable assembly (18).

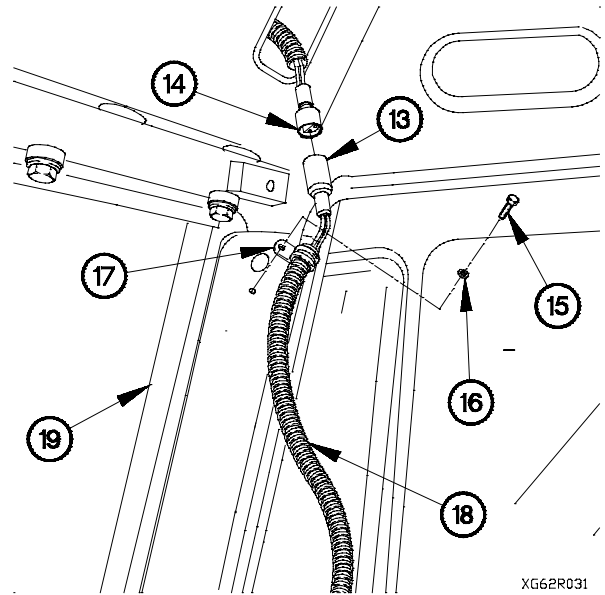

b. Installation.

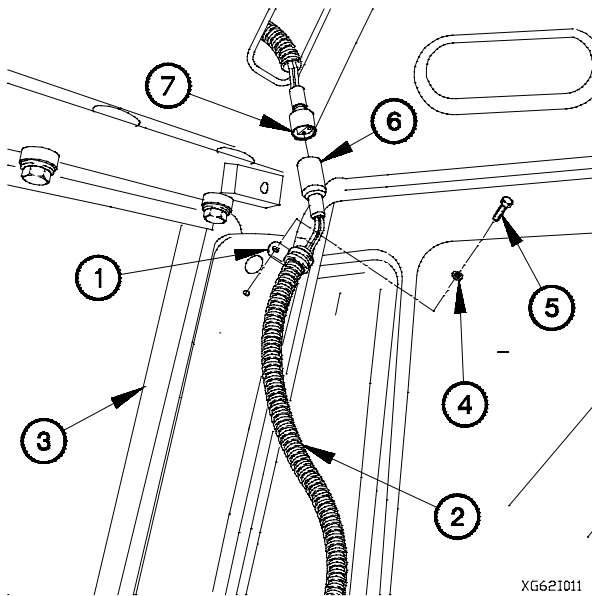

- (1) Install two clamps (1) on M1093/M1094 cab clearance and marker lights lower cable assembly (2).
- (2) Position M1093/M1094 cab clearance and marker lights lower cable assembly (2) in cab (3) with two clamps (1), washers (4), and screws (5).
- (3) Tighten two screws (5) to 29-35 lb-in. (3-4 N·m).
- (4) Connect connector P3 (6) to connector J3 (7).

- (5) Connect terminal lug TL86 (8) to terminal board TB2 (9) position 4.
- (6) Connect terminal lug TL74 (10) to terminal board TB1 (11) position 3.
- (7) Install cover (12) on terminal board TB1 (11) with two washers (13), lockwashers (14), and nuts (15).

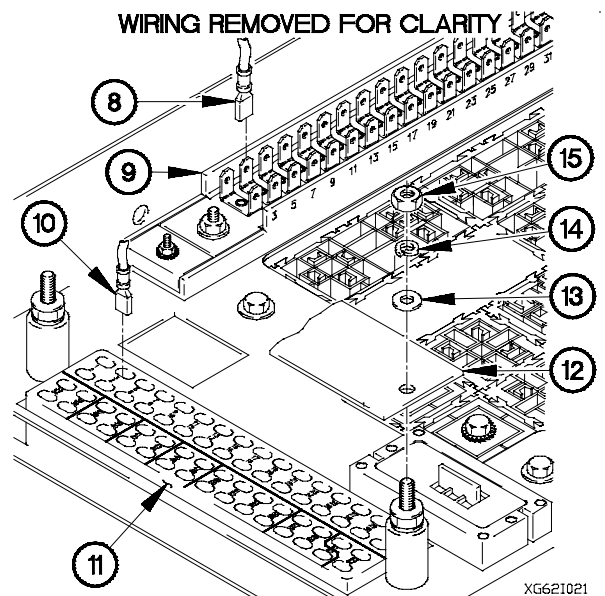

- (8) Position PDP (16) on dashboard (17).
- (9) Install three screws (18) in PDP (16).
- (10) Install three washers (19) and screws (20) in PDP (16).

c. Follow-On Maintenance.

- (1) Install PDP cover (para 16-2).
- (2) Connect batteries (para 7-57).
- (3) Check operation of cab clearance and marker lights (TM 9-2320-366-10-1).

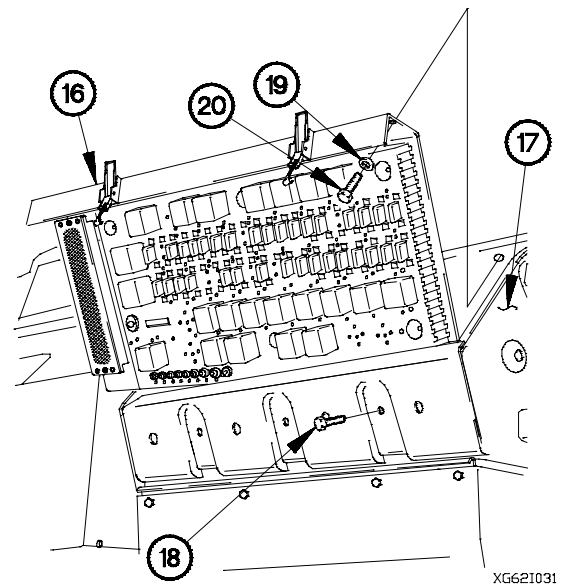

End of Task.

7-63. M1093/M1094 CAB CLEARANCE AND MARKER LIGHTS UPPER CABLE ASSEMBLY REPLACEMENT

This task covers:

- a. Removal
- b. Installation
- c. Follow-On Maintenance

INITIAL SETUP

Equipment Conditions

Batteries disconnected (para 7-57).

Tools and Special Tools

Tool Kit, Genl Mech (Item 46, Appendix C)
Wrench, Torque, 0-75 lb-in. (Item 90, Appendix B)

Materials/Parts

Lockwire (Item 30, Appendix D)
Gasket (5) (Item 24, Appendix G)
Lockwasher (10) (Item 82, Appendix G)

a. Removal.

- (1) Disconnect connector J3 (1) from connector P3 (2).

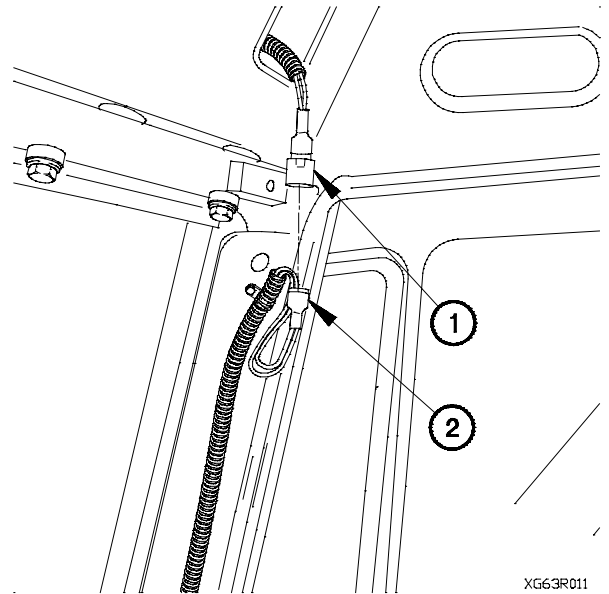

XG63R011

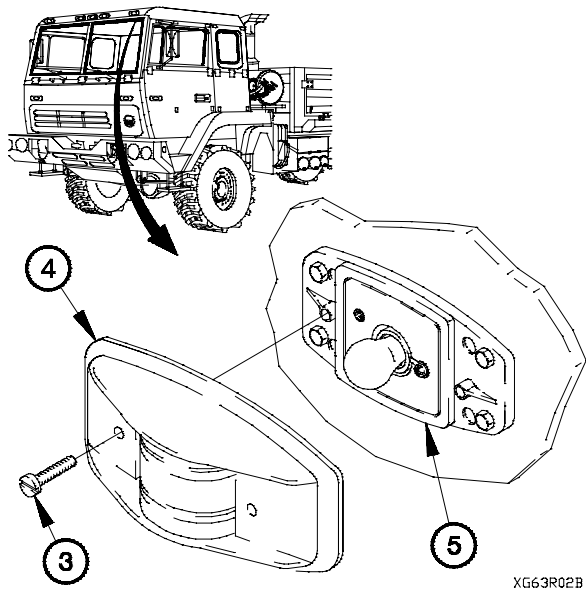

XG63R02B

NOTE

All M1093/M1094 cab clearance and marker lights are removed the same way. Upper left cab marker light shown.

- (2) Remove two screws (3) and lens cover (4) from marker light (5).

(3) Remove four screws (6) and marker light (5) from cab roof (7).

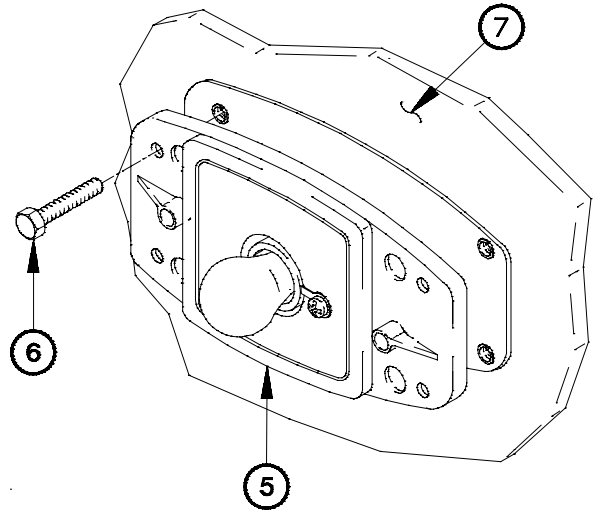

XG63R031

NOTE

- Wrap mechanics wire on each connector and terminal lug for ease of installation.
- Refer to **Table 7-3. M1093/M1094 Cab Clearance and Marker Lights Connectors** for combinations of terminal lugs and connectors on each light.

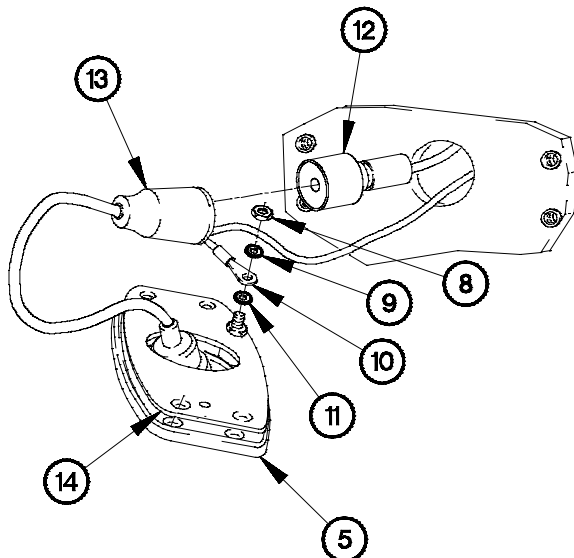

XG63R04B

- (4) Remove nut (8), lockwasher (9), terminal lug (10), and lockwasher (11) from marker light (5). Discard lockwashers.
- (5) Disconnect connector (12) from marker light connector 489 (13).
- (6) Remove gasket (14) from marker light (5). Discard gasket.

Table 7-3. M1093/M1094 Cab Clearance and Marker Lights Connectors

Light Location	Connector	Terminal lug
Left Side Marker	P50	TL27
Left Center Clearance	P57	TL22
Center Clearance	P60	TL8
Right Center Clearance	P59	TL4
Right Side Marker	P55	TL3

7-63. M1093/M1094 CAB CLEARANCE AND MARKER LIGHTS UPPER CABLE ASSEMBLY REPLACEMENT (CONT)

(7) Remove M1093/M1094 cab clearance and marker lights upper cable assembly (15) from cab roof (7).

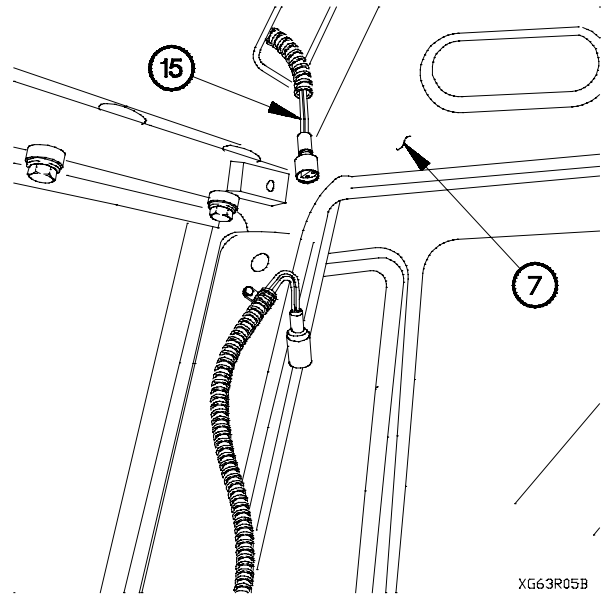

XG63R05B

b. Installation.

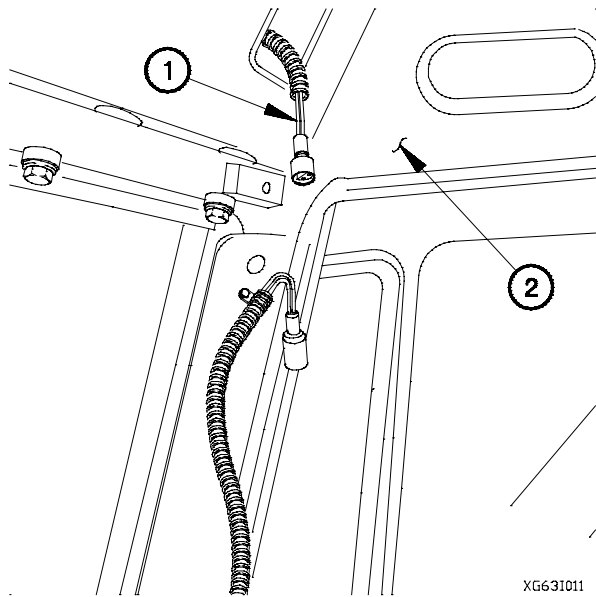

XG63I011

NOTE

- All M1093/M1094 cab clearance and marker lights are installed the same way. Upper left cab marker light shown.
- Refer to **Table 7-3. M1093/M1094 Cab Clearance and Marker Lights Connectors** for combinations of terminal lugs and connectors on each light.

- (2) Install gasket (3) on marker light (4).
- (3) Connect connector (5) to marker light connector 489 (6).
- (4) Install lockwasher (6.1) and terminal lug (7) on marker light (4) with lockwasher (8) and nut (9).

NOTE

Transfer mechanics wire to new M1093/M1094 cab clearance and marker lights upper cable assembly.

(1) Position M1093/M1094 cab clearance and marker lights upper cable assembly (1) in cab roof (2).

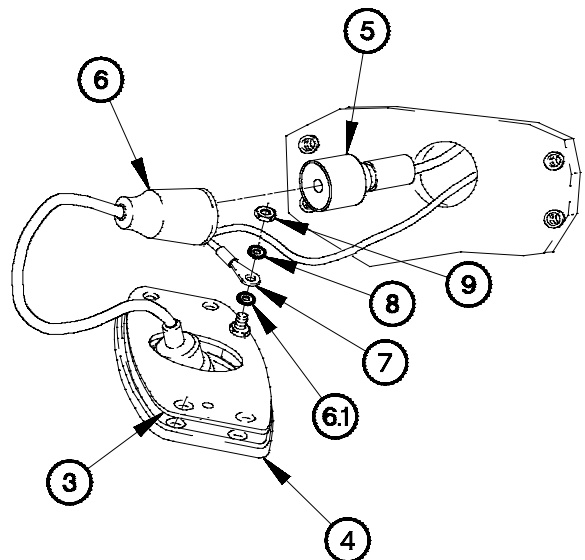

XG63I02B

(5) Install marker light (4) on cab roof (2) with four screws (10).

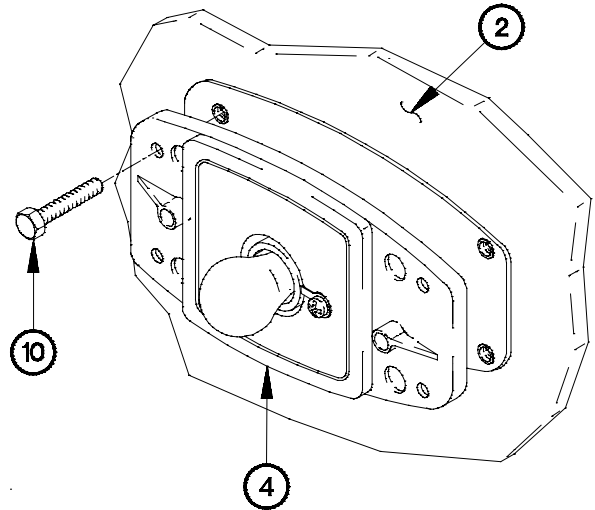

XG63103B

(6) Install lens cover (11) on marker light (4) with two screws (12).

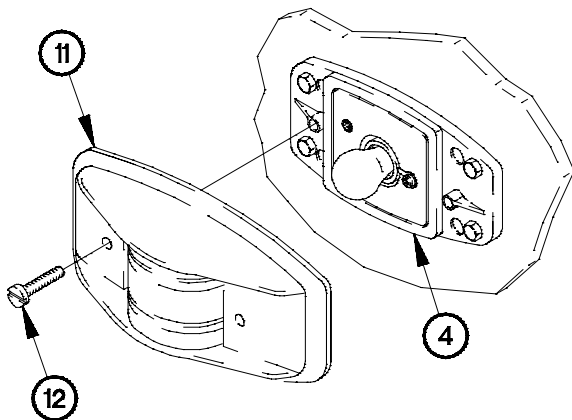

XG63104B

(7) Connect connector J3 (13) to connector P3 (14).

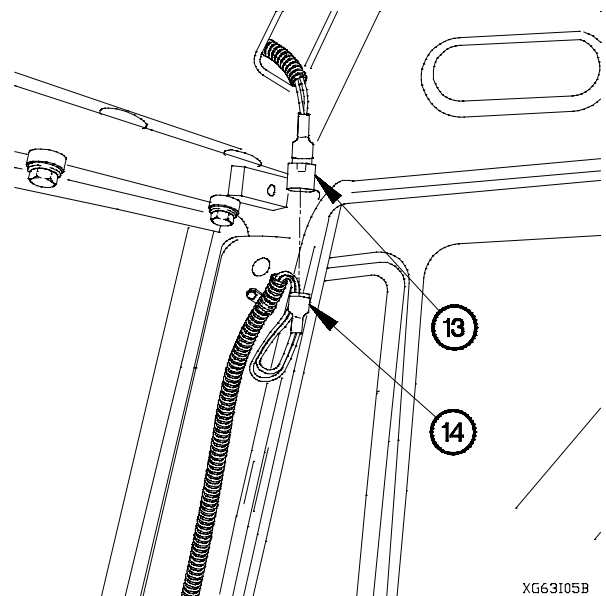

XG63105B

c. Follow-On Maintenance.

- (1) Connect batteries (para 7-57).
- (2) Check operation of cab clearance and marker lights (TM 9-2320-366-10-1).

End of Task.

7-64. RIGHT-HAND DOOR AND CAB MARKER LIGHTS CABLE ASSEMBLY REPLACEMENT

This task covers:

- a. Removal
- b. Installation
- c. Follow-On Maintenance

INITIAL SETUP

Equipment Conditions

- Batteries disconnected (para 7-57).
- PDP cover removed (para 16-2).

Tools and Special Tools

- Tool Kit, Genl Mech (Item 46, Appendix C)

Materials/Parts

- Ties, Cable, Plastic (Item 69, Appendix D)
- Lockwasher (4) (Item 82, Appendix G)
- Lockwasher (2) (Item 88, Appendix G)
- Gasket (2) (Item 24, Appendix G)

a. Removal.

NOTE

- Note routing of right-hand door and cab marker lights cable assembly prior to removal.
- Remove plastic cable ties as required.

- (1) Remove three screws (1) and washers (2) from PDP (3).
- (2) Remove three screws (4) from PDP (3).
- (3) Lift PDP (3) outward to gain access.

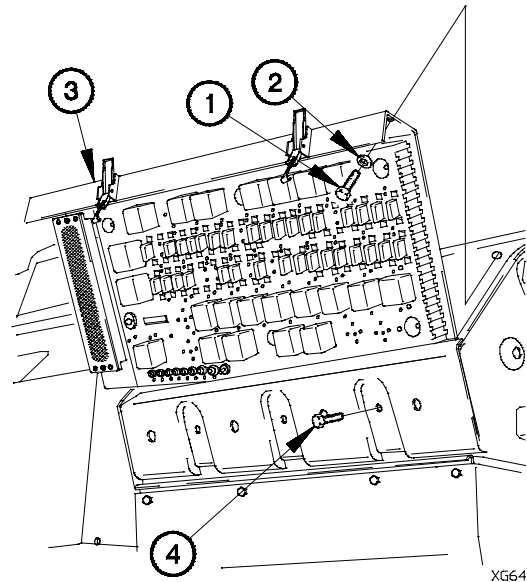

XG64R011

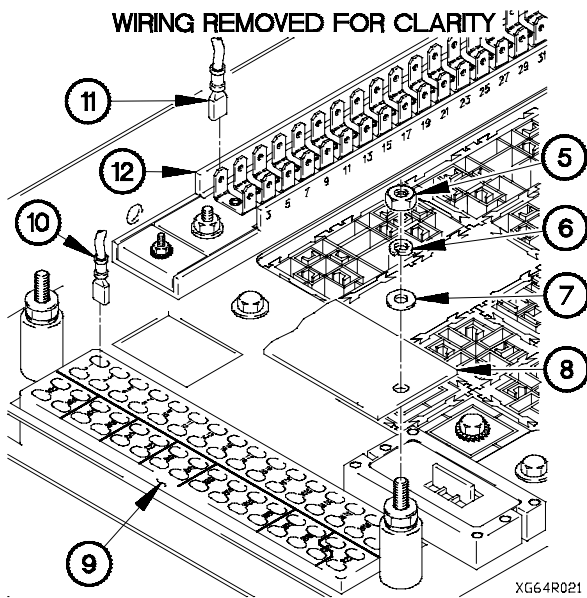

XG64R021

- (4) Remove two nuts (5), lockwashers (6), washers (7), and cover (8) from terminal board TB1 (9). Discard lockwashers.
- (5) Disconnect terminal lug TL73 (10) from terminal board TB1 (9) position 1.
- (6) Disconnect terminal lug TL71 (11) from terminal board TB2 (12) position 2.

- (7) Remove two screws (13) and marker lens cover (14) from marker light (15).

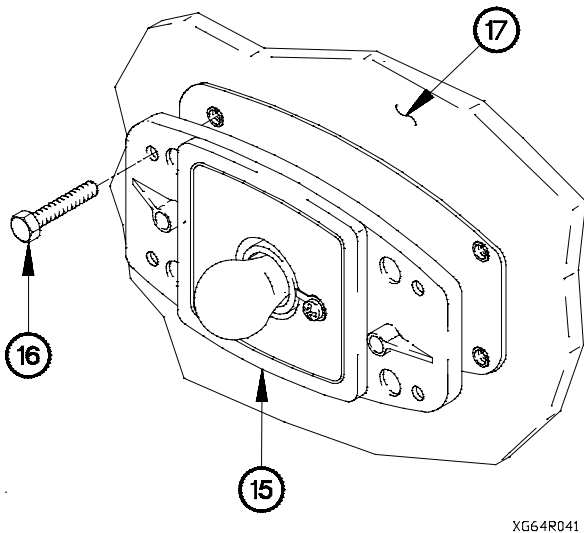
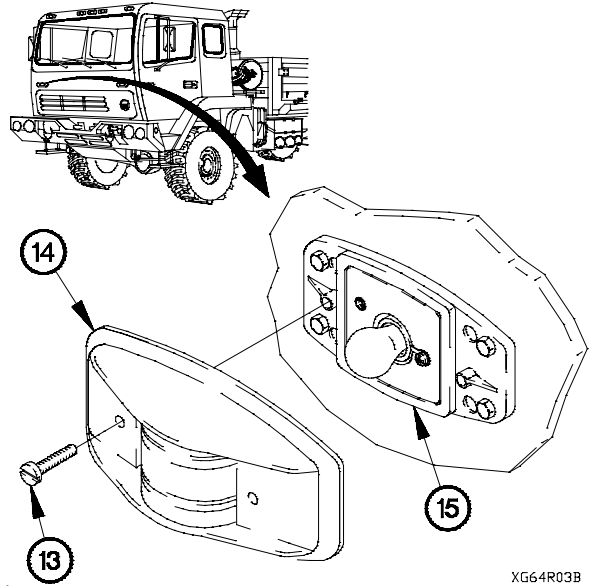

- (8) Remove four screws (16) and marker light (15) from cab (17).

- (9) Remove nut (18), lockwasher (19), terminal lug TL134 (20), and lockwasher (20.1) from marker light (15). Discard lockwashers.
- (10) Disconnect connector P132 (21) from marker light connector 489 (22).
- (11) Remove gasket (23) from marker light (15). Discard gasket.

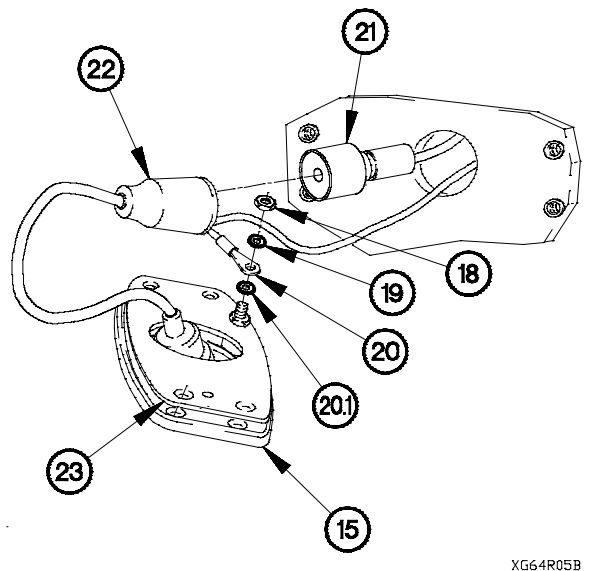

7-64. RIGHT-HAND DOOR AND CAB MARKER LIGHTS CABLE ASSEMBLY REPLACEMENT (CONT)

(12) Remove two screws (24) and marker lens cover (25) from marker light (26).

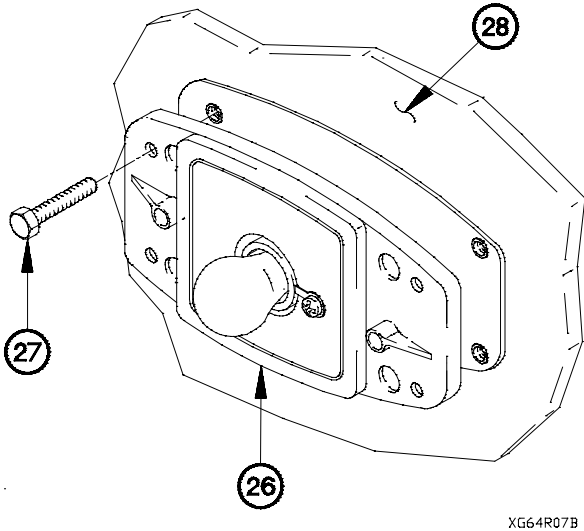
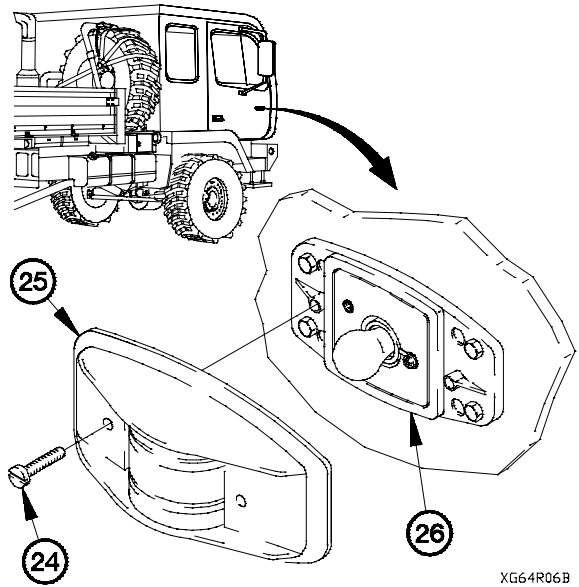

(13) Remove four screws (27) and marker light (26) from door (28).

(14) Remove nut (29), lockwasher (30), terminal lug TL131 (31), and lockwasher (31.1) from marker light (26). Discard lockwashers.

(15) Disconnect connector P131 (32) from marker light connector 489 (33).

(16) Remove gasket (34) from marker light (26). Discard gasket.

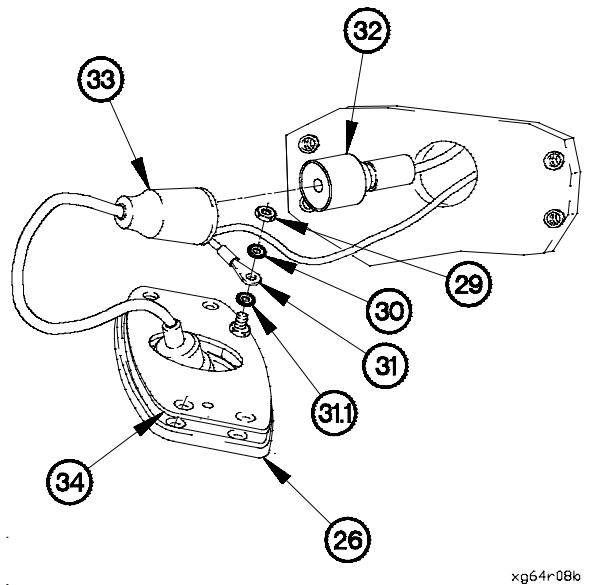

- (17) Remove tube protector (35) and right-hand door and cab marker lights cable assembly (36) from door (28).
- (18) Remove right-hand door and cab marker lights cable assembly (36) dashboard (37).

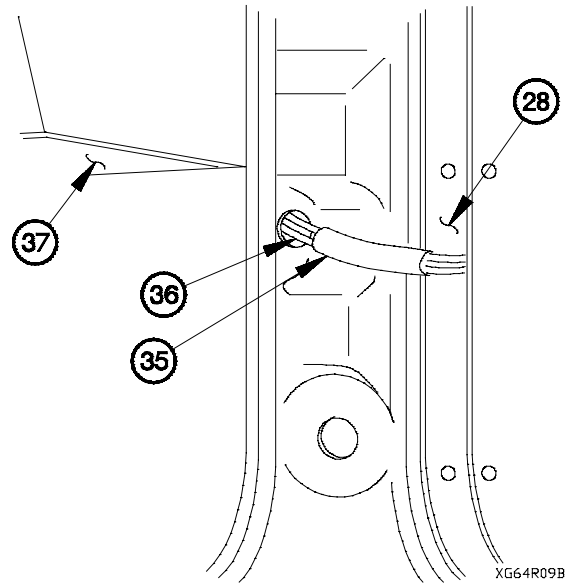

b. Installation.

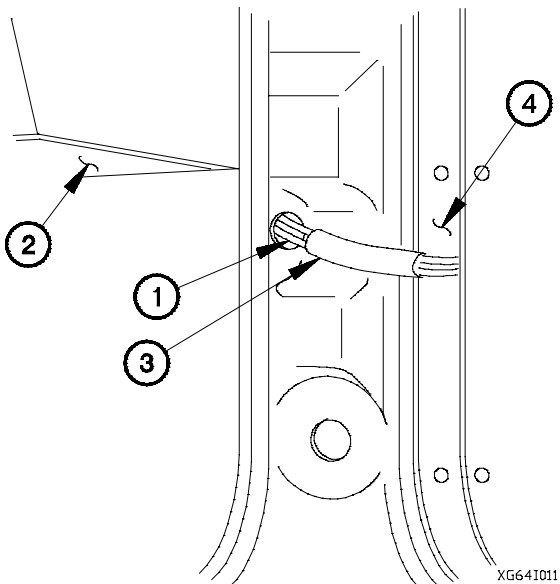

NOTE

Install plastic cable ties as required.

- (1) Position right-hand door and cab marker lights cable assembly (1) in dashboard (2).
- (2) Install right-hand door and cab marker lights cable assembly (1) and tube protector (3) in door (4).

- (3) Install gasket (5) on marker light (6).
- (4) Connect connector P131 (7) to marker light connector 489 (8).
- (5) Install lockwasher (8.1) and terminal lug TL131 (9) on marker light (6) with lockwasher (10) and nut (11).

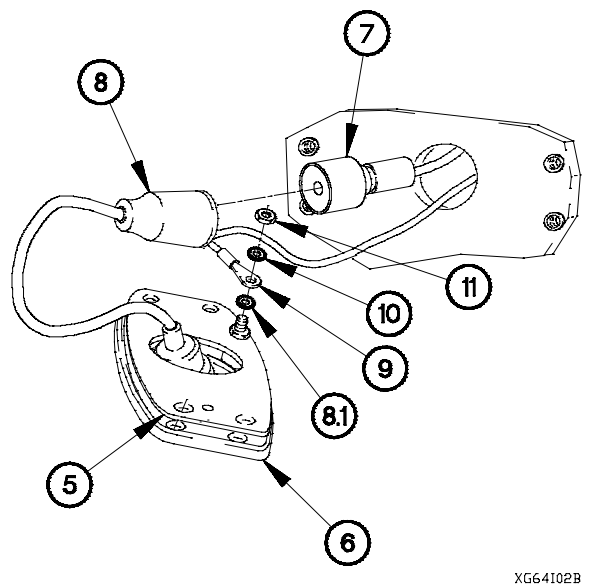

7-64. RIGHT-HAND DOOR AND CAB MARKER LIGHTS CABLE ASSEMBLY REPLACEMENT (CONT)

(6) Install marker light (6) on door (3) with four screws (12).

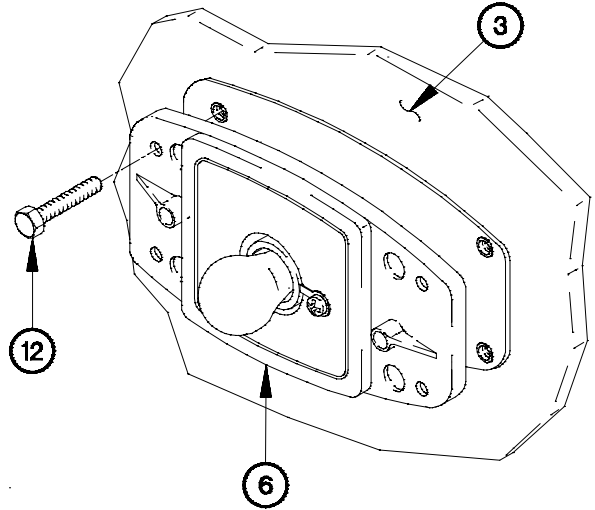

XG64103B

(7) Install marker lens cover (13) on marker light (6) with two screws (14).

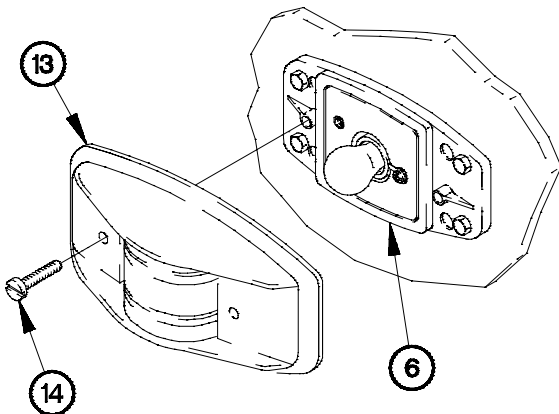

XG64104B

(8) Install gasket (15) on marker light (16).

(9) Connect connector P132 (17) to marker light connector 489 (18).

(10) Install lockwasher (18.1) and terminal lug TL134 (19) on marker light (16) with lockwasher (20) and nut (21).

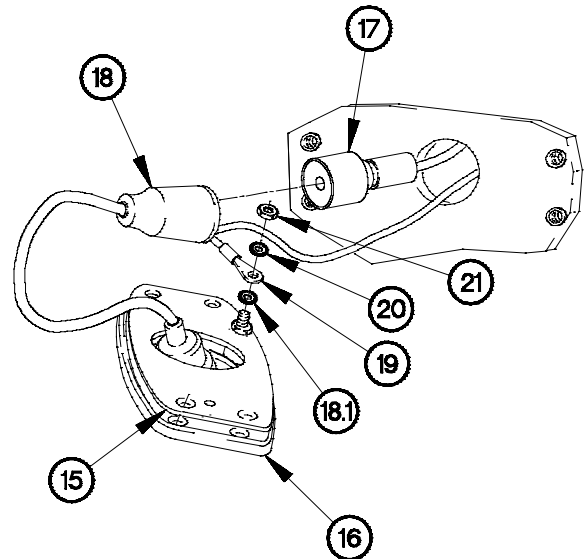

XG64105B

(11) Install marker light (16) on cab (22) with four screws (23).

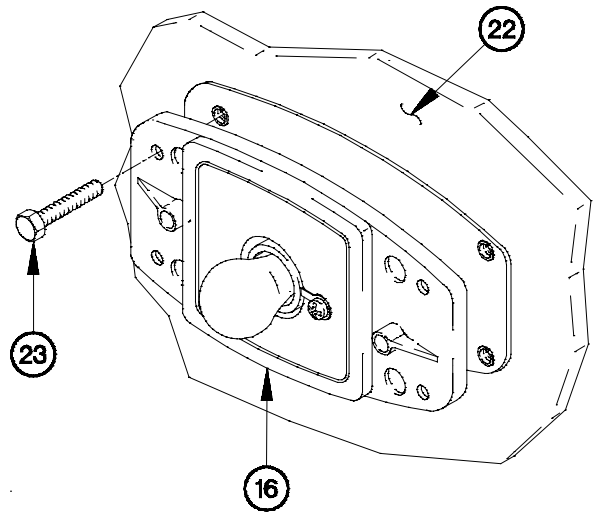

xa641061.dwg

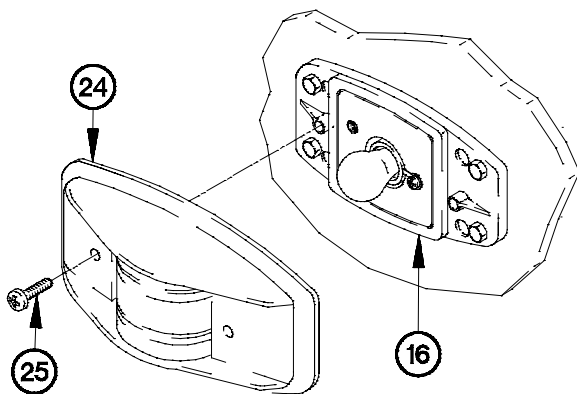

xa641071.dwg

(12) Install marker lens cover (24) on marker light (16) with two screws (25).

(13) Connect terminal lug TL71 (26) to terminal board TB2 (27) position 2.

(14) Connect terminal lug TL73 (28) to terminal board TB1 (29) position 1.

(15) Install cover (30) on terminal board TB1 (29) with two washers (31), lockwashers (32), and nuts (33).

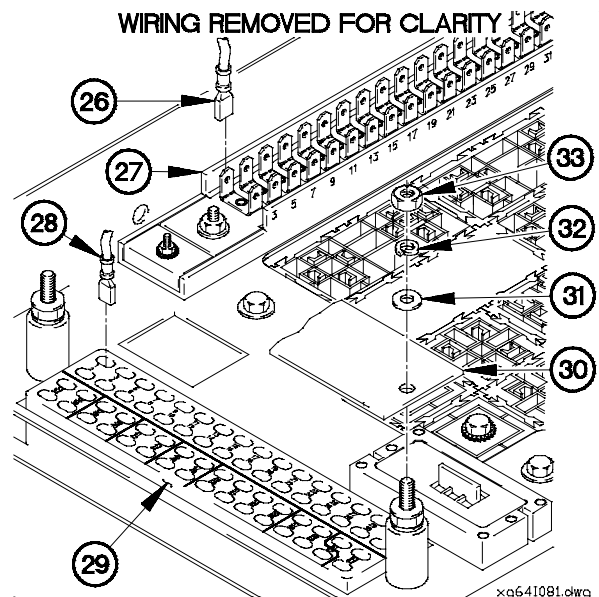

xa641081.dwg

7-64. RIGHT-HAND DOOR AND CAB MARKER LIGHTS CABLE ASSEMBLY REPLACEMENT (CONT)

- (16) Position PDP (34) on dashboard (2) with three screws (35).
- (17) Deleted.
- (18) Install three washers (36) and screws (37) in PDP (34).

c. Follow-On Maintenance.

- (1) Install PDP cover (para 16-2).
- (2) Connect batteries (para 7-57).
- (3) Check operation of right-hand door and cab marker lights (TM 9-2320-366-10-1).

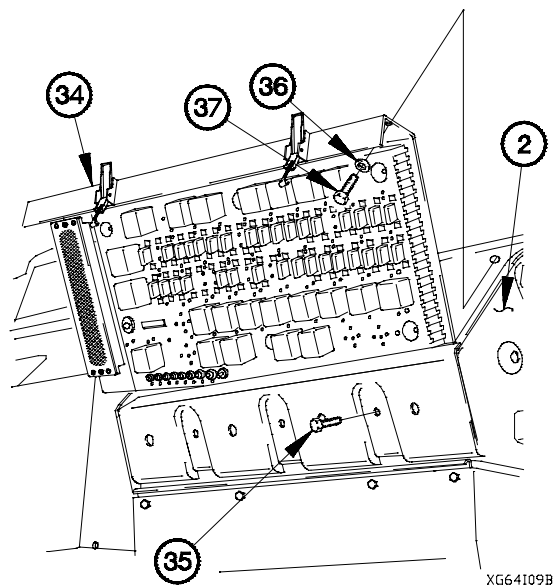

End of Task.

7-65. STE/ICE-R CABLE ASSEMBLY REPLACEMENT

This task covers:

- a. Removal
- b. Installation
- c. Follow-On Maintenance

INITIAL SETUP

Equipment Conditions

Instrument panel assembly removed for access (para 7-15).

Materials/Parts

Ties, Cable, Plastic (Item 69, Appendix D)
Lockwasher (4) (Item 76, Appendix G)

Tools and Special Tools

Tool Kit, Genl Mech (Item 46, Appendix C)

a. Removal.

NOTE

Remove plastic cable ties as required.

- (1) Disconnect connector J31X (1) from connector P31X (2).
- (2) Disconnect connector J43X (3) from connector P43X (4).

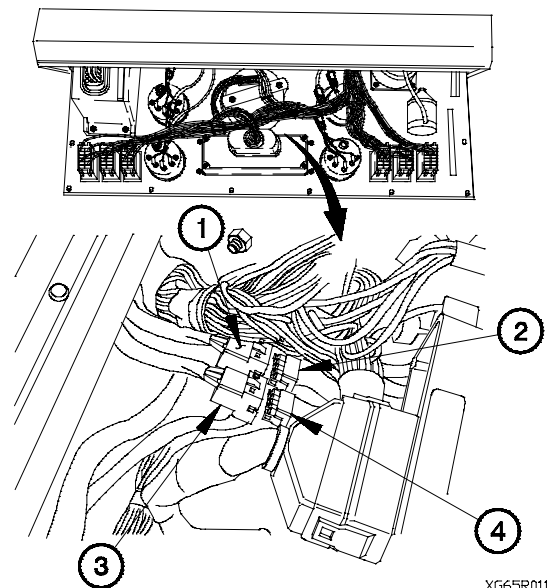

XG65R011

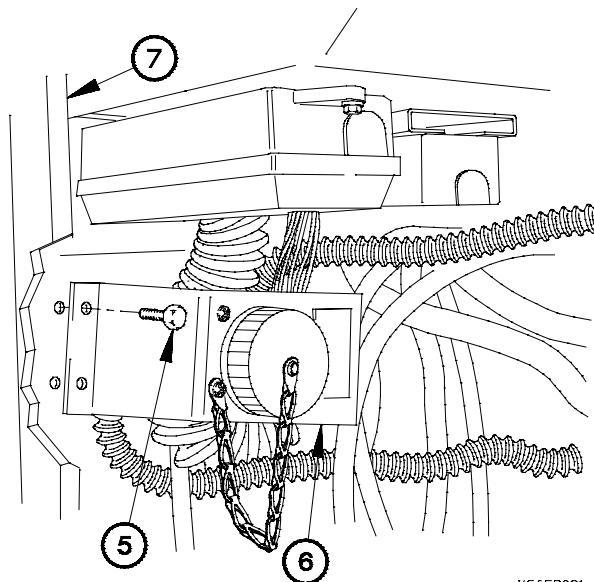

XG65R021

- (3) Remove two screws (5) and bracket (6) from cab (7).

7-65. STE/ICE-R CABLE ASSEMBLY REPLACEMENT (CONT)

- (4) Remove two screws (8), washers (9), junction box (10), and STE/ICE-R cable assembly (11) from dashboard (12).

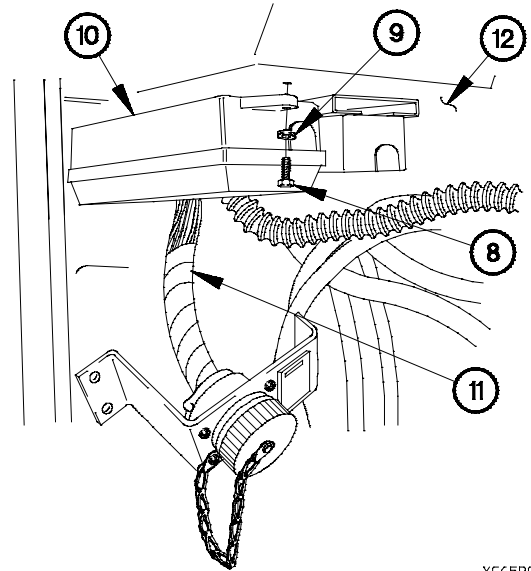

XG65R031

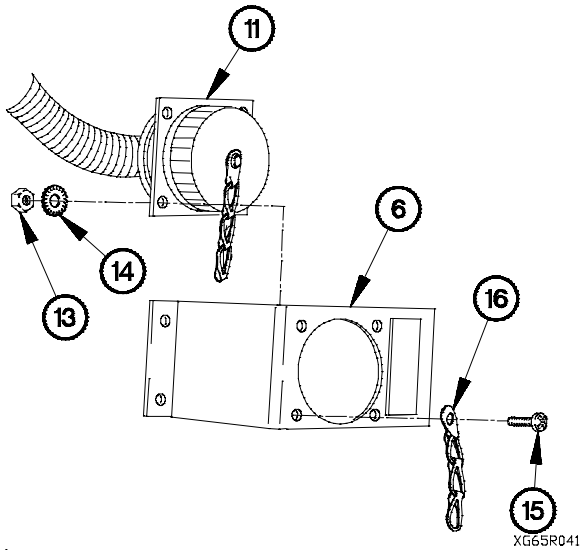

XG65R041

- (5) Remove four nuts (13), lockwashers (14), screws (15), chain (16), and bracket (6) from STE/ICE-R cable assembly (11). Discard lockwashers.

b. Installation.

NOTE

Install plastic cable ties as required.

- (1) Install bracket (1) on STE/ICE-R cable assembly (2) with chain (3), four screws (4), lockwashers (5), and nuts (6).

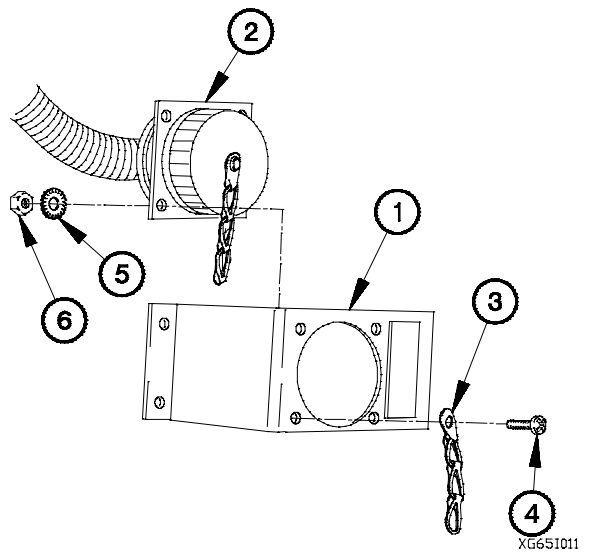

XG65I011

- (2) Position STE/ICE-R cable assembly (2) in dashboard (7).
- (3) Install junction box (8) on dashboard (7) with two washers (9) and screws (10).

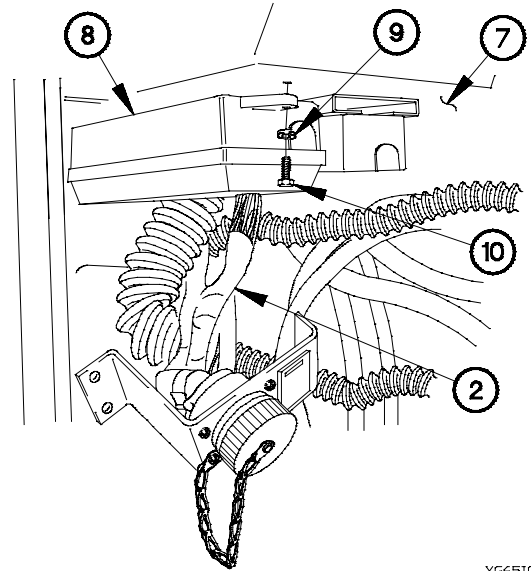

XG65I021

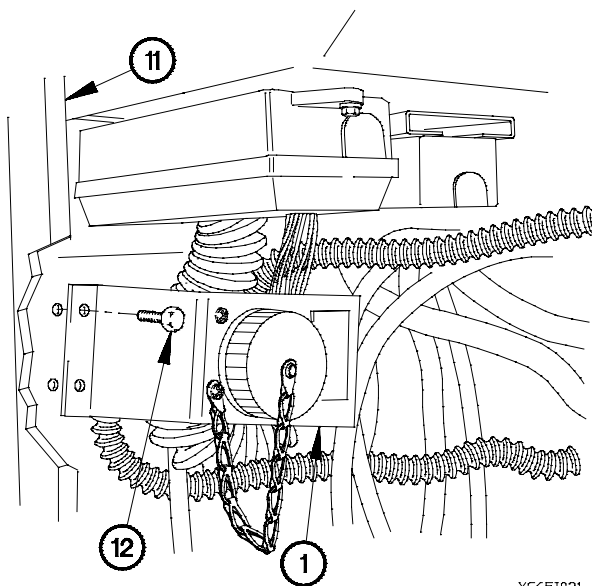

XG65I031

- (4) Install bracket (1) on cab (11) with two screws (12).

- (5) Connect connector J43X (13) to connector P43X (14).
- (6) Connect connector J31X (15) to connector P31X (16).

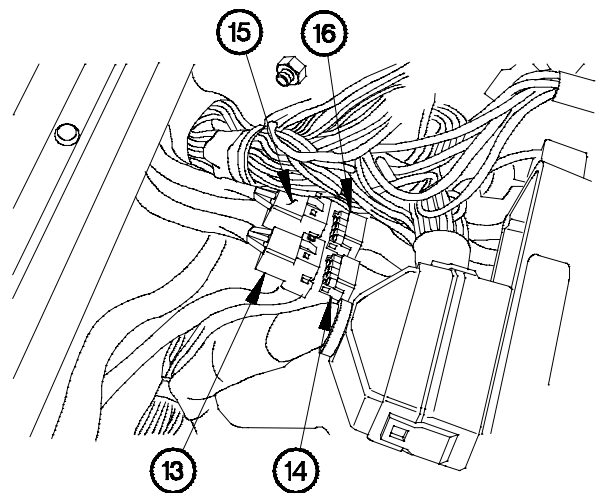

XG65I041

c. Follow-On Maintenance.

Install instrument panel assembly (para 7-15).

End of Task.

7-66. CAB CLEARANCE MARKER LIGHTS CABLE ASSEMBLY REPLACEMENT

This task covers:

- a. Removal
- b. Installation
- c. Follow-On Maintenance

INITIAL SETUP

Equipment Conditions

- Batteries disconnected (para 7-57).
- PDP cover removed (para 16-2).

Tools and Special Tools

- Tool Kit, Genl Mech (Item 46, Appendix C)
- Wrench, Torque, 0-200 lb-in. (Item 59, Appendix C)
- Socket Set, Socket Wrench (Item 34, Appendix C)

Materials/Parts

- Lockwire (Item 30, Appendix D)
- Lockwasher (10) (Item 82, Appendix G)
- Lockwasher (2) (Item 88, Appendix G)
- Gasket (5) (Item 24, Appendix G)

a. Removal.

- (1) Remove three screws (1) and washers (2) from PDP (3).
- (2) Remove three screws (4) from PDP (3).
- (3) Lift PDP (3) outward to gain access.

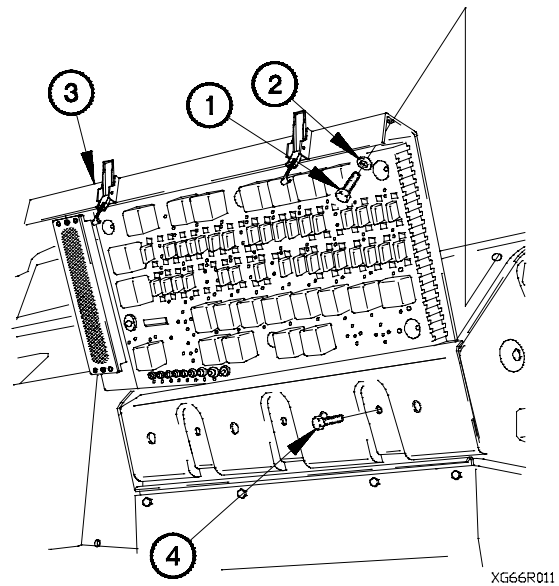

XG66R011

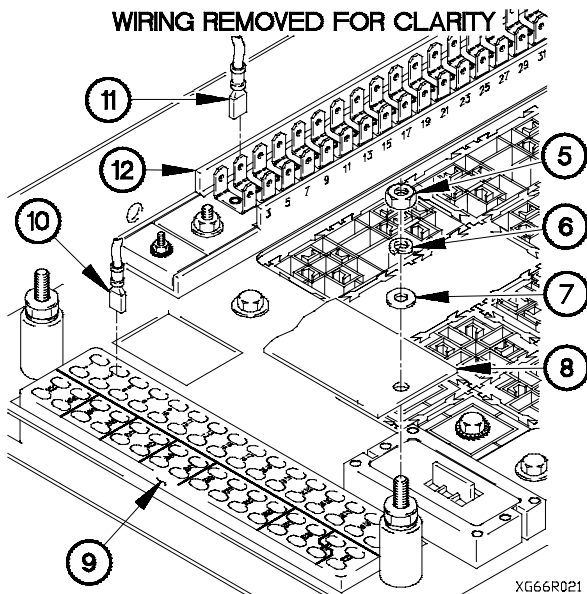

XG66R021

- (4) Remove two nuts (5), lockwashers (6), washers (7), and cover (8) from terminal board TB1 (9). Discard lockwashers.
- (5) Disconnect terminal lug TL74 (10) from terminal board TB1 (9) position 3.
- (6) Disconnect terminal lug TL86 (11) from terminal board TB2 (12) position 4.

NOTE

All cab clearance marker lights are removed the same way. Upper left cab clearance marker light shown.

- (7) Remove two screws (13) and marker lens cover (14) from marker light (15).

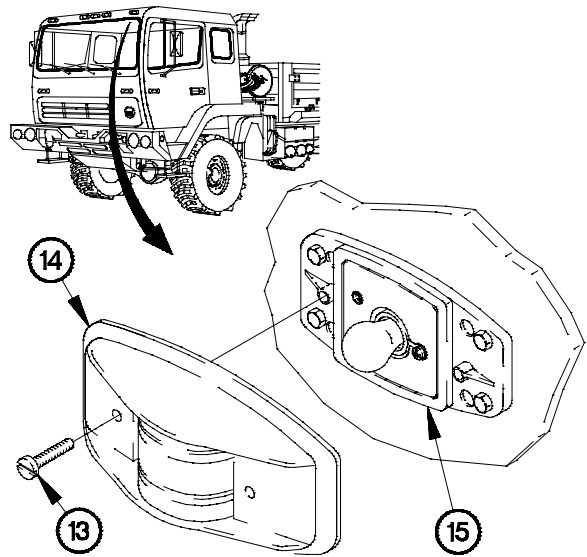

XG66R03B

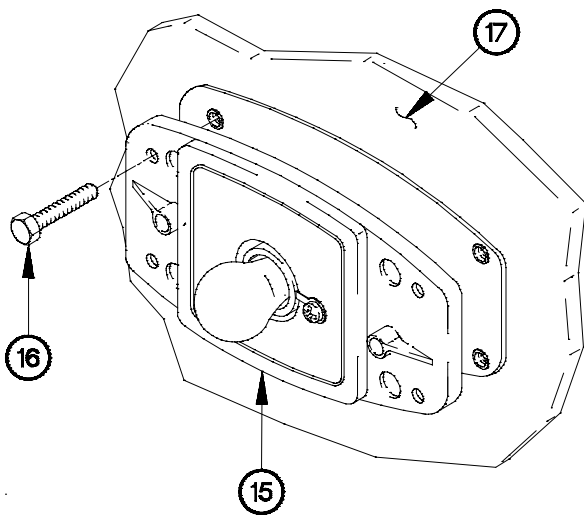

XG66R041

- (8) Remove four screws (16) and marker light (15) from cab (17).

NOTE

- Wrap mechanics wire on each connector and terminal lug for ease of installation.
- Refer to **Table 7-4. Cab Clearance Marker Light Connectors** for combinations of terminal lugs and connectors on each marker light.

- (9) Remove nut (18), lockwasher (19), terminal lug (20), and lockwasher (20.1) from marker light (15). Discard lockwashers.
- (10) Disconnect connector (21) from marker light connector 489 (22).
- (11) Remove gasket (23) from marker light (15). Discard gasket.

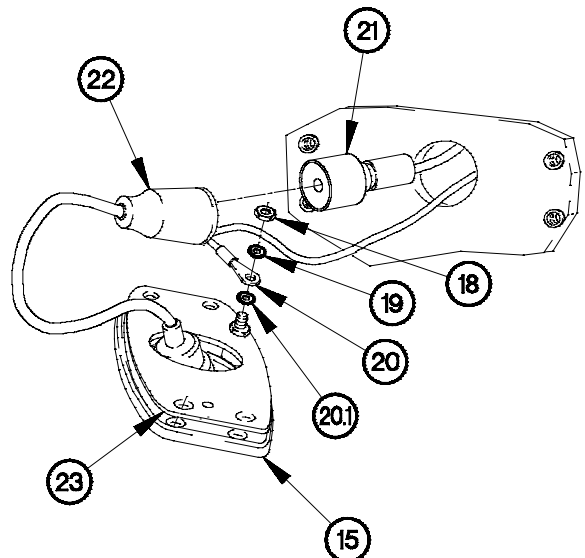

XG66R05B

7-66. CAB CLEARANCE MARKER LIGHTS CABLE ASSEMBLY REPLACEMENT (CONT)

Table 7-4. Cab Clearance Marker Light Connectors

Marker Light Location	Connector	Terminal lug
Left Side	P50	TL27
Left Center	P59	TL4
Center	P60	TL8
Right Center	P57	TL22
Right Side	P55	TL3

- (12) Remove eight screws (24), washers (25), clamps (26), and cab clearance marker lights cable assembly (27) from cab (17).
- (13) Remove eight clamps (26) from cab clearance marker lights cable assembly (27).

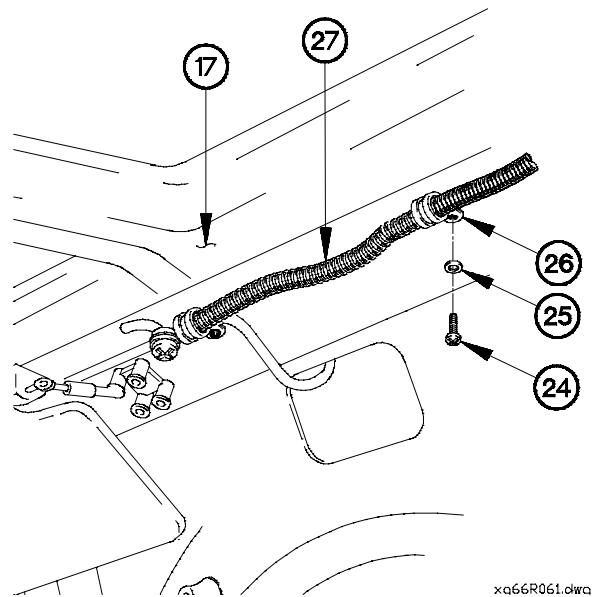

b. Installation.

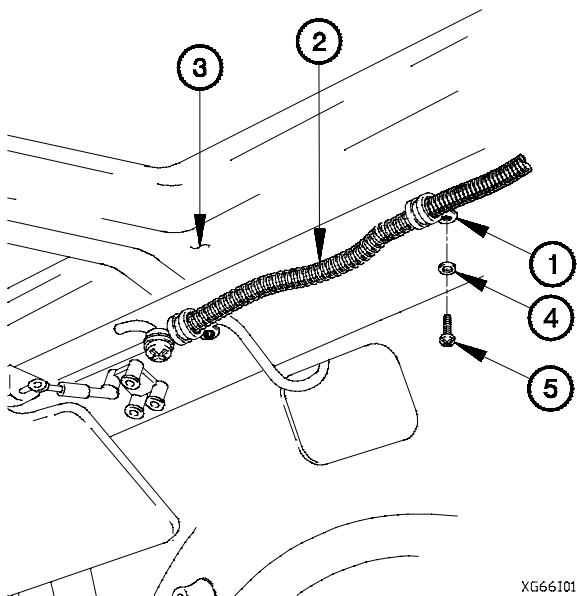

NOTE

Transfer mechanics wire to new cab clearance marker lights cable assembly.

- (1) Install eight clamps (1) on cab clearance marker lights cable assembly (2).
- (2) Install cab clearance marker lights cable assembly (2) on cab (3) with eight clamps (1), washers (4), and screws (5).

NOTE

- All cab clearance marker lights are installed the same way. Upper left cab clearance marker light shown.
- Refer to **Table 7-4. Cab Clearance Marker Light Connectors** for combinations of terminal lugs and connectors on each marker light.

- (3) Install gasket (6) on marker light (7).
- (4) Connect connector (8) to marker light connector 489 (9).
- (5) Install lockwasher (9.1) and terminal lug (10) on marker light (7) with lockwasher (11) and nut (12).

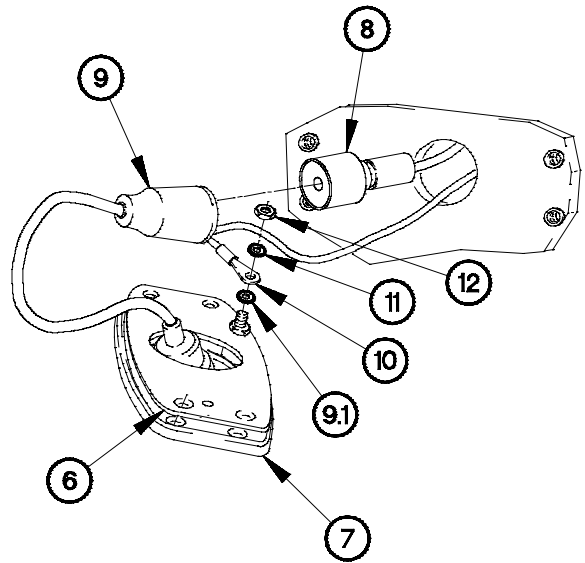

XG66102B

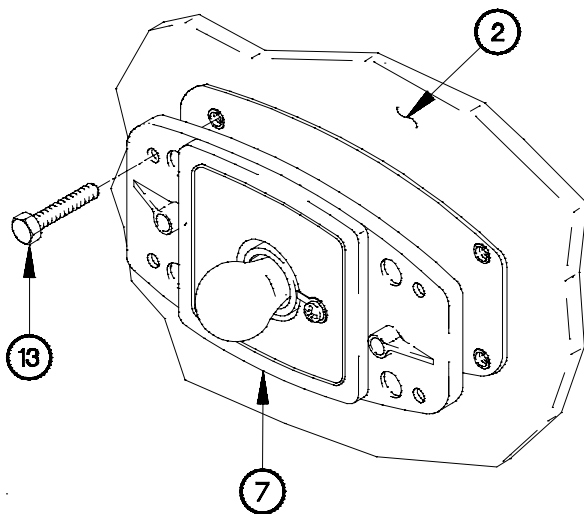

XG66103B

- (6) Install marker light (7) on cab (2) with four screws (13).

- (7) Install marker lens cover (14) on marker light (7) with two screws (15).

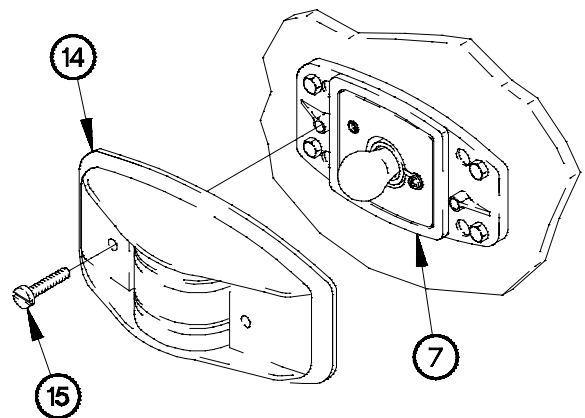

XG66104B

7-66. CAB CLEARANCE MARKER LIGHTS CABLE ASSEMBLY REPLACEMENT (CONT)

- (8) Connect terminal lug TL86 (16) to terminal board TB2 (17) position 4.
- (9) Connect terminal lug TL74 (18) to terminal board TB1 (19) position 3.
- (10) Install cover (20) on terminal board TB1 (19) with two washers (21), lockwashers (22), and nuts (23).

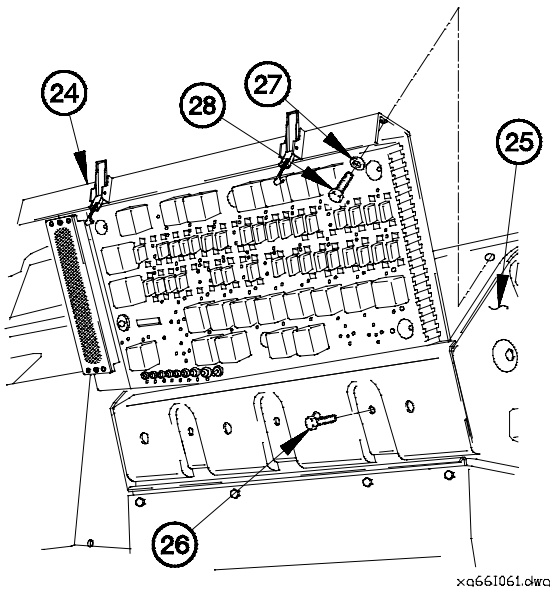
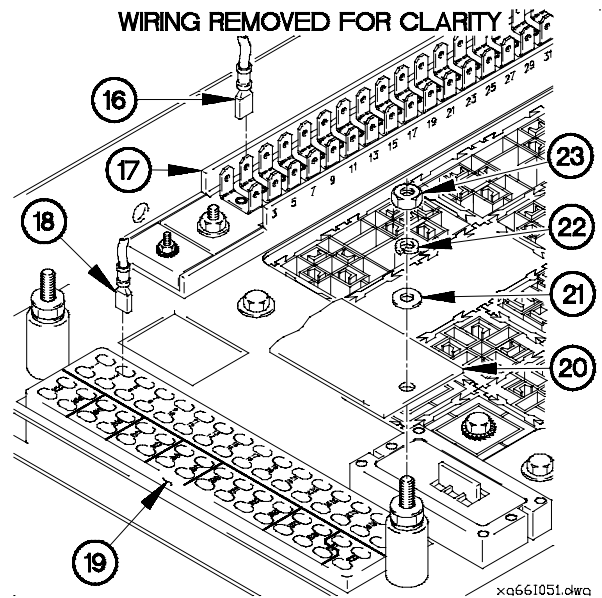

- (11) Position PDP (24) on dashboard (25).
- (12) Install three screws (26) in PDP (24).
- (13) Install three washers (27) and screws (28) in PDP (24).

c. Follow-On Maintenance.

- (1) Install PDP cover (para 16-2).
- (2) Connect batteries (para 7-57).
- (3) Check operation of cab clearance marker lights (TM 9-2320-366-10-1).

End of Task.

<p>7-67. WINDSHIELD WASHER PUMP ELECTROMAGNETIC INTERFERENCE (EMI) CABLE REPLACEMENT</p>	
<p>This task covers:</p> <p>a. Removal b. Installation</p> <p>c. Follow-On Maintenance</p>	
<p>INITIAL SETUP</p> <p>Equipment Conditions Batteries disconnected (para 7-57).</p> <p>Materials/Parts Nut, Self-Locking (Item 167, Appendix G)</p> <p>Tools and Special Tools Tool Kit, Genl Mech (Item 46, Appendix C)</p>	

a. Removal.

- (1) Loosen screw (1) and open cab step tread (2).

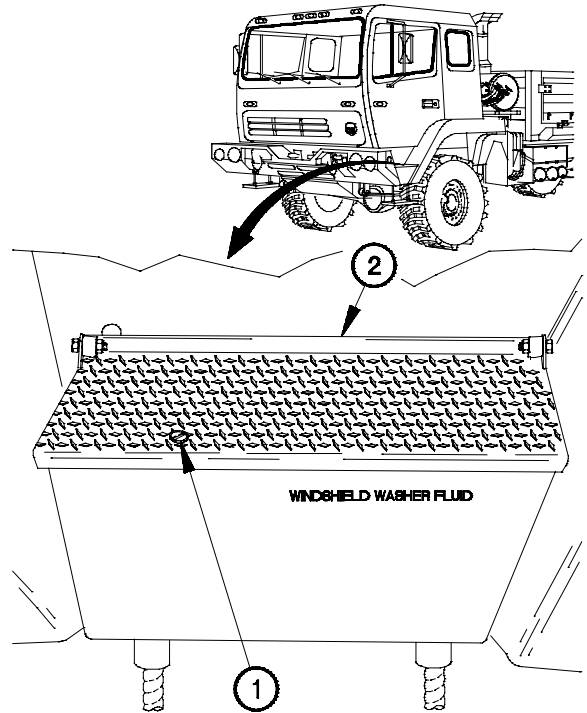

XG67R011

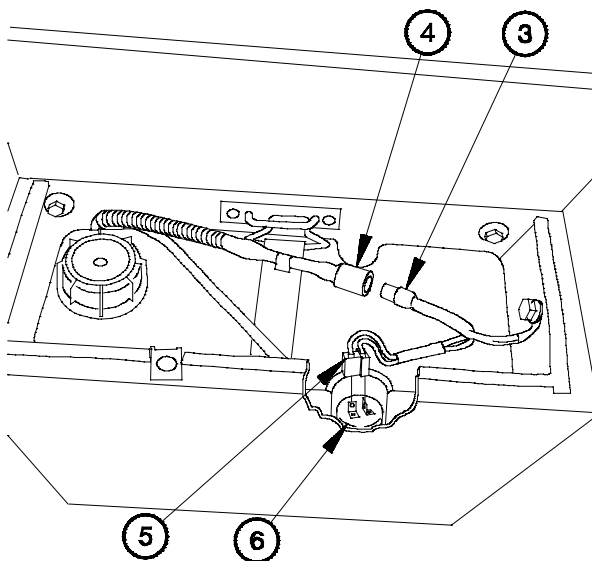

XG67R021

- (2) Disconnect connector J25 (3) from connector P25 (4).
- (3) Disconnect connector P125 (5) from windshield washer pump (6).

7-67. WINDSHIELD WASHER PUMP ELECTROMAGNETIC INTERFERENCE (EMI) CABLE REPLACEMENT (CONT)

(4) Remove self-locking nut (7), washer (8), screw (9), washer (10), terminal lug TL94 (11), and windshield washer pump EMI cable (12) from box (13). Discard self-locking nut.

b. Installation.

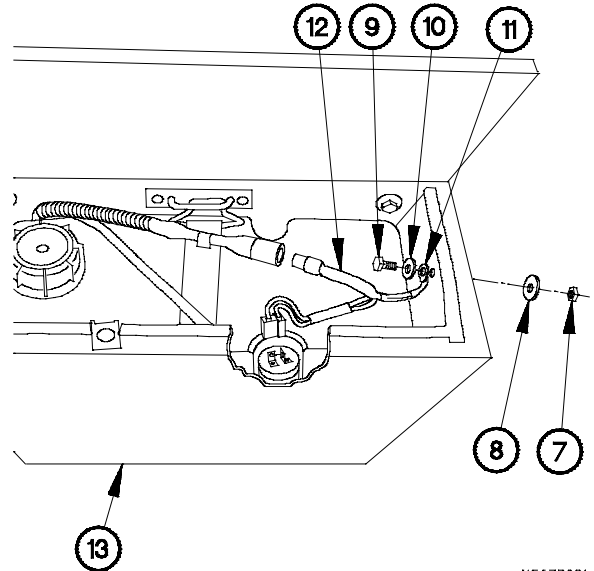

XG67R031

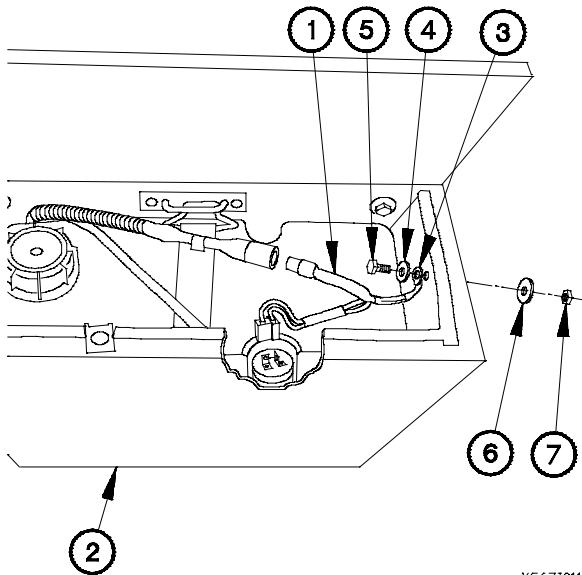

XG67I011

- (1) Position windshield washer pump EMI cable (1) in box (2).
- (2) Install terminal lug TL94 (3) on box (2) with washer (4), screw (5), washer (6), and self-locking nut (7).

- (3) Connect connector P125 (8) to windshield washer pump (9).
- (4) Connect connector P25 (10) to connector J25 (11).

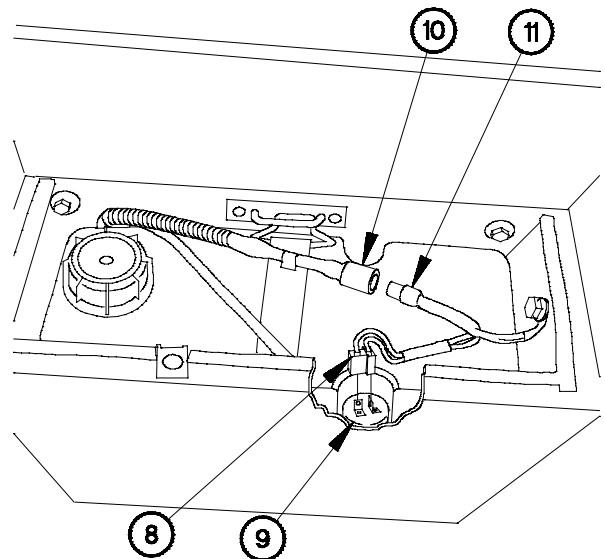

XG67I021

(5) Close cover (12) and tighten screw (13).

c. Follow-On Maintenance.

- (1) Connect batteries (para 7-57).
- (2) Check operation of windshield washers (TM 9-2320-366-10-1).

End of Task.

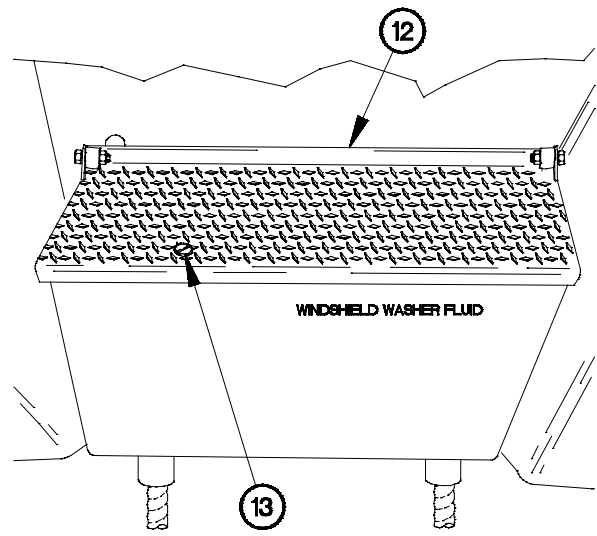

XG671031

7-68. WINDSHIELD WIPER ELECTROMAGNETIC INTERFERENCE (EMI) CABLE REPLACEMENT

This task covers:

- a. Removal
- b. Installation
- c. Follow-On Maintenance

INITIAL SETUP

Equipment Conditions

Batteries disconnected (para 7-57).
 PDP cover removed (para 16-2).

Materials/Parts

Ties, Cable, Plastic (Item 69, Appendix D)

Tools and Special Tools

Tool Kit, Genl Mech (Item 46, Appendix C)

a. Removal.

- (1) Remove three screws (1) and washers (2) from PDP (3).
- (2) Remove three screws (4) from PDP (3).
- (3) Lift PDP (3) outward to gain access.

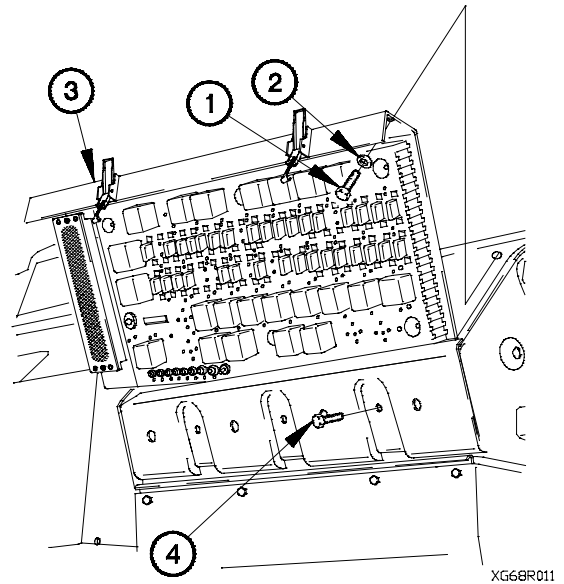

XG68R011

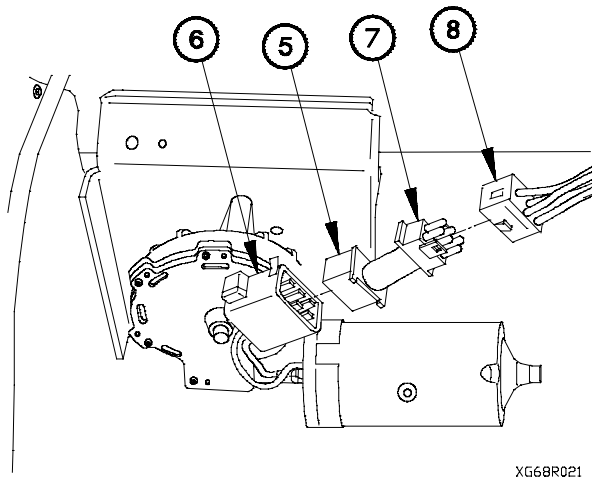

XG68R021

NOTE

Remove plastic cable ties as required.

- (4) Disconnect windshield wiper EMI cable connector PX22 (5) from windshield wiper motor (6).
- (5) Disconnect windshield wiper EMI cable connector P2 (7) from connector J2 (8).

b. Installation.

NOTE

Install plastic cable ties as required.

- (1) Connect windshield wiper EMI cable connector P2 (1) to connector J2 (2).
- (2) Connect windshield wiper EMI cable connector PX22 (3) to windshield wiper motor (4).

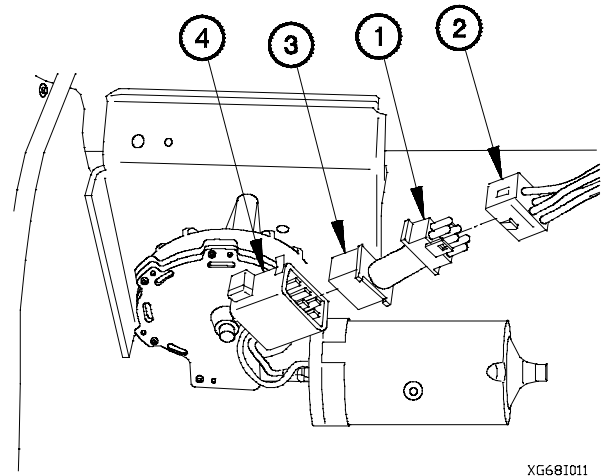

XG681011

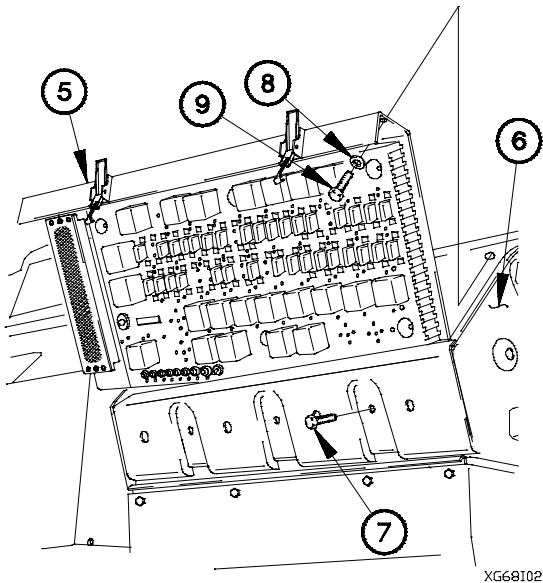

XG681021

- (3) Position PDP (5) on dashboard (6).
- (4) Install three screws (7) in PDP (5).
- (5) Install three washers (8) and screws (9) in PDP (5).

c. Follow-On Maintenance.

- (1) Install PDP cover (para 16-2).
- (2) Connect batteries (para 7-57).
- (3) Check operation of windshield wipers (TM 9-2320-366-10-1).

End of Task.

7-69. WINDSHIELD WIPER ECU REPLACEMENT	
This task covers:	
a. Removal b. Installation	c. Follow-On Maintenance
INITIAL SETUP	
Equipment Conditions Batteries disconnected (para 7-57). PDP cover removed (para 16-2).	

a. Removal.

Remove windshield wiper ECU (1) from PDP (2).

b. Installation.

Install windshield wiper ECU (1) in PDP (2).

c. Follow-On Maintenance.

- (1) Install PDP cover (para 16-2).
- (2) Connect batteries (para 7-57).
- (3) Check operation of windshield wipers (TM 9-2320-366-10-1).

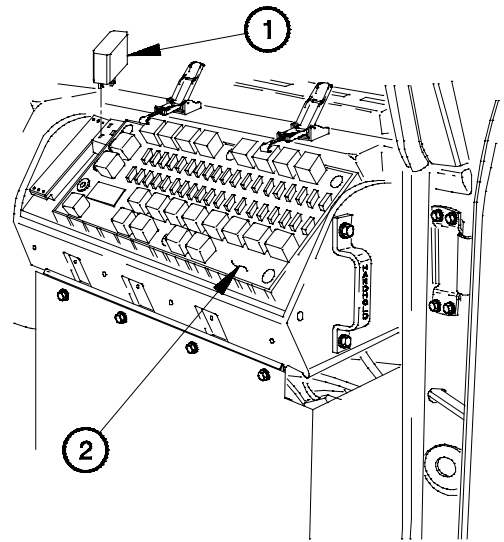

XG69X011

End of Task.

7-70. NATO POWER CABLE REPLACEMENT	
This task covers:	
a. Removal b. Installation	c. Follow-On Maintenance
INITIAL SETUP	
Equipment Conditions Engine shut down (TM 9-2320-366-10-1). Battery box cover removed (TM 9-2320-366-10-2).	Materials/Parts Dispenser, Pressure Sensitive Adhesive Tape (Item 20, Appendix D) Grease, Automotive and Artillery (GAA) (Item 22, Appendix D) Nut, Self-Locking (4) (Item 158, Appendix G) Lockwasher (Item 87, Appendix G)
Tools and Special Tools Goggles, Industrial (Item 15, Appendix C) Gloves, Rubber (Item 13, Appendix C) Apron, Rubber (Item 3, Appendix C) Tool Kit, Genl Mech (Item 46, Appendix C)	

a. Removal.



- Remove rings, bracelets, watches, necklaces, and any other jewelry before working around vehicle. Jewelry can catch on equipment and cause injury or short across electrical circuit and cause severe burns or electrical shock. Batteries can explode from a spark. Battery acid is harmful to skin and eyes. Always wear eye protection when working with batteries. Failure to comply may result in injury to personnel.
- Negative battery terminals and battery tester negative terminal lug must be disconnected first. Failure to comply may result in serious injury or death to personnel.

NOTE

Tag battery terminals, terminal lugs, and connection points prior to disconnecting.

- (1) Remove nut (1) and lockwasher (2) from battery ground cable (3). Discard lockwasher.

NOTE

Perform step (2) on vehicles equipped with cargo arctic heater.

- (2) Remove terminal lug TL2 (4) from battery ground cable (3).
- (3) Remove terminal lugs TL50A (5), TL48 (6), and battery tester terminal lug (7) from battery ground cable (3).

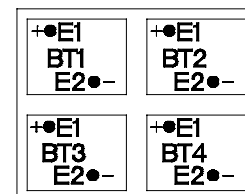

BATTERY INSTALLATION DIAGRAM

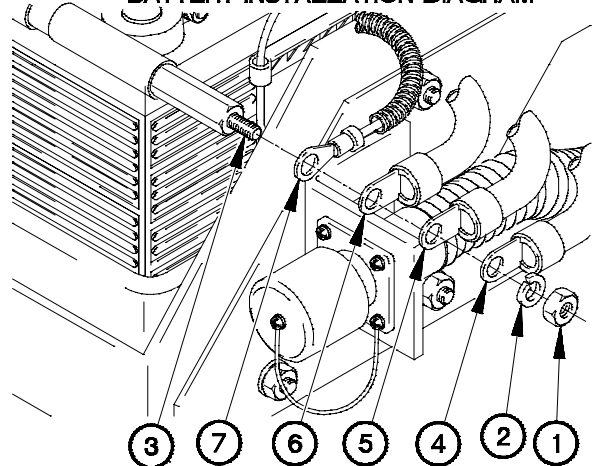

XG70R011

7-70. NATO POWER CABLE REPLACEMENT (CONT)

(4) Remove nut (8) from battery 24 vdc cable (9).

NOTE

Perform step (5) on vehicles equipped with cargo arctic heater.

(5) Remove terminal lug TL1 (10) from battery 24 vdc cable (9).

(6) Remove terminal lug TL49A (11) and battery tester terminal lug (12) from battery 24 vdc cable (9).

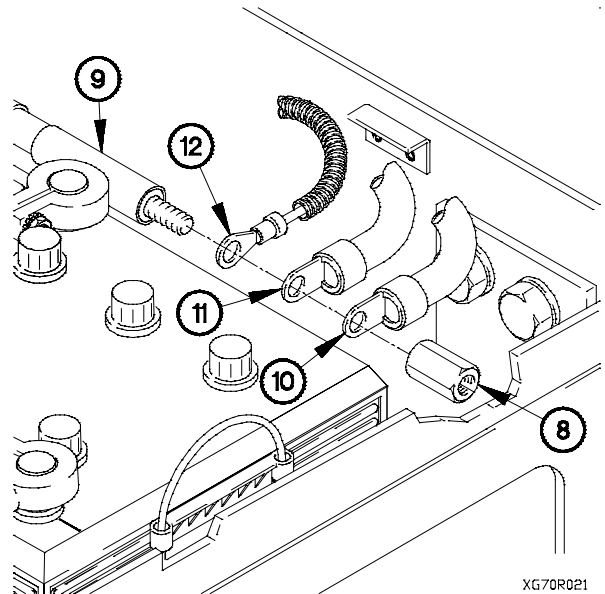

XG70R021

(7) Remove four self-locking nuts (13), washers (14), screws (15), and eyelet (16) from NATO power cable (17). Discard self-locking nuts.

(8) Remove NATO power cable (17) and terminal lugs TL49A (11) and TL50A (5) from bracket (18) and battery box (19).

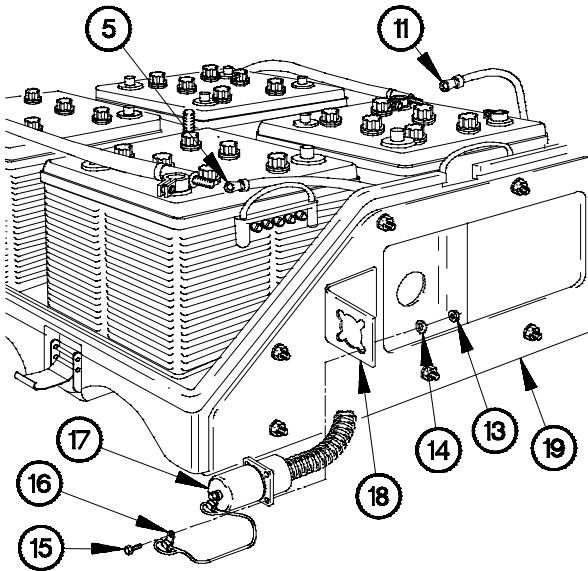

XG70R031

b. Installation.

(1) Position terminal lugs TL49A (1) and TL50A (2), and NATO power cable (3) in bracket (4) and battery box (5).

(2) Install NATO power cable (3) and eyelet (6) on bracket (4) with four screws (7), washers (8), and self-locking nuts (9).

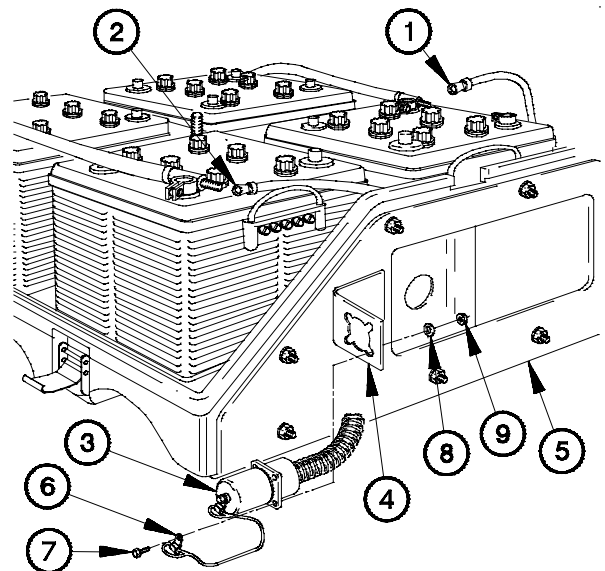

XG70I011

WARNING

Negative battery terminals must be connected last. Failure to comply may result in serious injury or death to personnel.

- (3) Install battery tester terminal lug (10) and terminal lug TL49A (1) on battery 24 vdc cable (11).

NOTE

Perform step (4) on vehicles equipped with cargo arctic heater.

- (4) Install terminal lug TL1 (12) on battery 24 vdc cable (11).
- (5) Install nut (13) on battery 24 vdc cable (11).

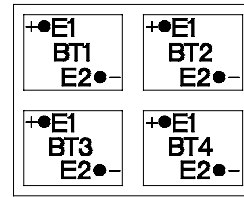
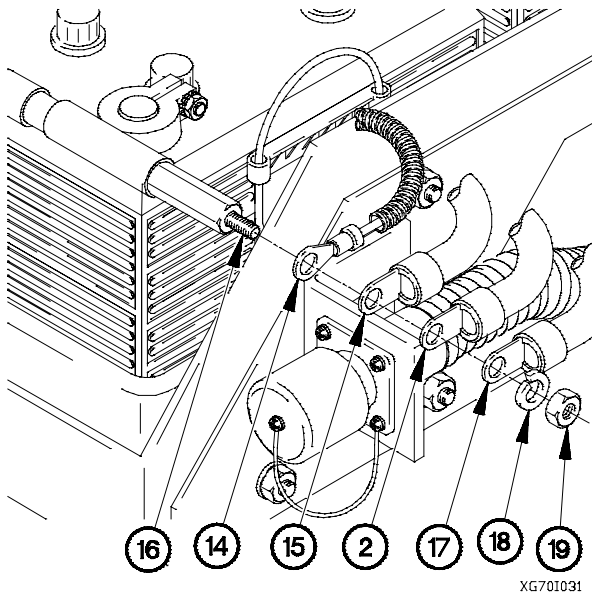

BATTERY INSTALLATION DIAGRAM

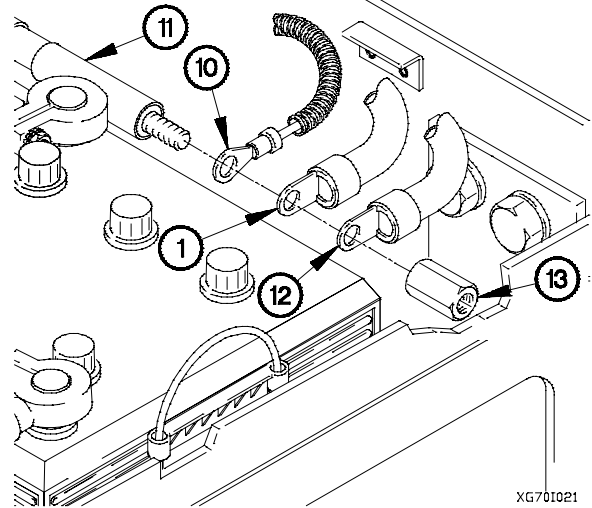

- (6) Install battery tester terminal lug (14), and terminal lugs TL48 (15) and TL50A (2) on battery ground cable (16).

NOTE

Perform step (7) on vehicles equipped with cargo arctic heater.

- (7) Install terminal lug TL2 (17) on battery ground cable (16).
- (8) Install lockwasher (18) and nut (19) on battery ground cable (16).
- (9) Apply grease to all battery terminals.

c. Follow-On Maintenance.

Install battery box cover (TM 9-2320-366-10-2).

End of Task.

7-71. ALTERNATOR GROUND STRAP REPLACEMENT

This task covers:

- a. Removal
- b. Installation
- c. Follow-On Maintenance

INITIAL SETUP

Equipment Conditions

- Cab raised (TM 9-2320-366-10-1).
- Batteries disconnected (para 7-57).

Tools and Special Tools

- Tool Kit, Genl Mech (Item 46, Appendix C)

Materials/Parts

- Lockwasher (Item 103, Appendix G)
- Lockwasher (Item 81, Appendix G)
- Nut, Self-Locking (Item 158, Appendix G)

a. Removal.

- (1) Remove screw (1), lockwasher (2), washer (3), terminal lug TL5 (4), and ground cable (5) from alternator (6). Discard lockwasher.

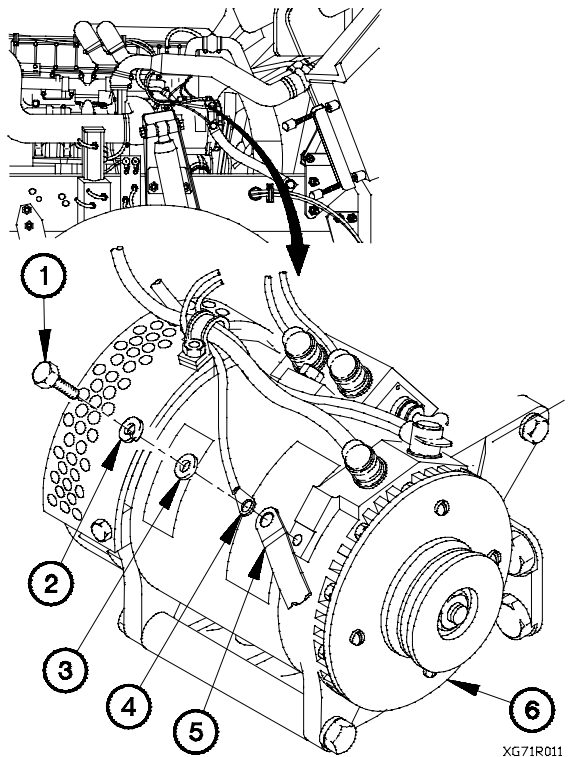

XG71R011

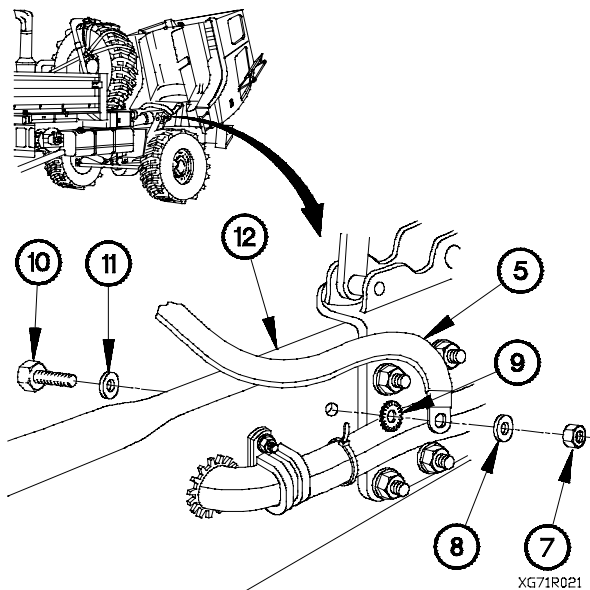

XG71R021

- (2) Remove self-locking nut (7), washer (8), ground cable (5), lockwasher (9), screw (10), and washer (11) from right frame rail (12). Discard self-locking nut and lockwasher.

b. Installation.

- (1) Install lockwasher (1) and ground cable (2) on right frame rail (3) with washer (4), screw (5), washer (6) and self-locking nut (7).

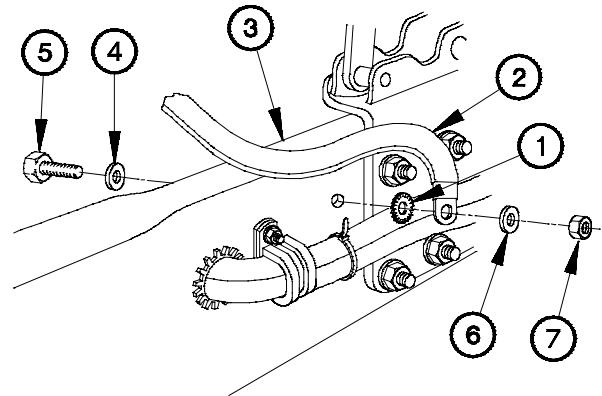

XG711011

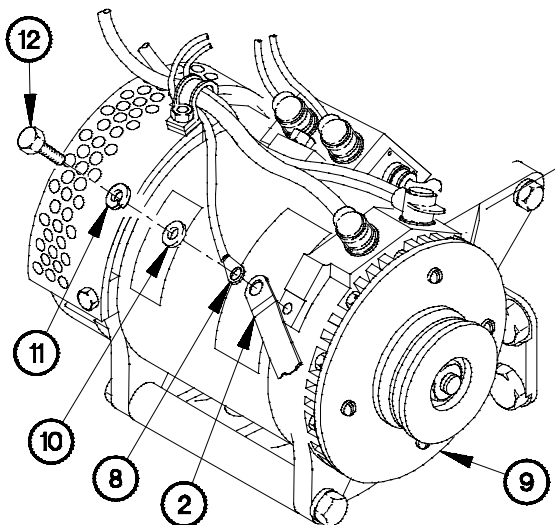

XG711021

- (2) Install ground cable (2) and terminal lug TL5 (8) on alternator (9) with washer (10), lockwasher (11), and screw (12).

c. Follow-On Maintenance.

- (1) Connect batteries (para 7-57).
- (2) Lower cab (TM 9-2320-366-10-1).
- (3) Start engine (TM 9-2320-366-10-1).
- (4) Check VOLTS gage for charge indication (TM 9-2320-366-10-1).
- (5) Shut down engine (TM 9-2320-366-10-1).

End of Task.

7-72. 100 AMP ALTERNATOR TO REVERSE POLARITY RELAY 12 VDC CABLE REPLACEMENT

This task covers:

- a. Removal
- b. Installation
- c. Follow-On Maintenance

INITIAL SETUP

Equipment Conditions

- Spare tire lowered (TM 9-2320-366-10-2).
- Cab raised (TM 9-2320-366-10-1).
- Batteries disconnected (para 7-57).

Tools and Special Tools

- Tool Kit, Genl Mech (Item 46, Appendix C)
- Wrench, Torque, 0-175 lb-ft (Item 58, Appendix C)
- Wrench, Torque, 0-200 lb-in. (Item 59, Appendix C)
- Socket Set, Socket Wrench (Item 34, Appendix C)

Materials/Parts

- Dispenser, Pressure Sensitive Adhesive Tape (Item 20, Appendix D)
- Ties, Cable, Plastic (Item 69, Appendix D)
- Lockwasher (Item 96, Appendix G)
- Nut, Self-Locking (Item 144.1, Appendix G)

a. Removal.

- (1) Loosen clamp (1) on turbocharger intake hose (2).
- (2) Remove turbocharger intake hose (2) from intake air cleaner boot (3).

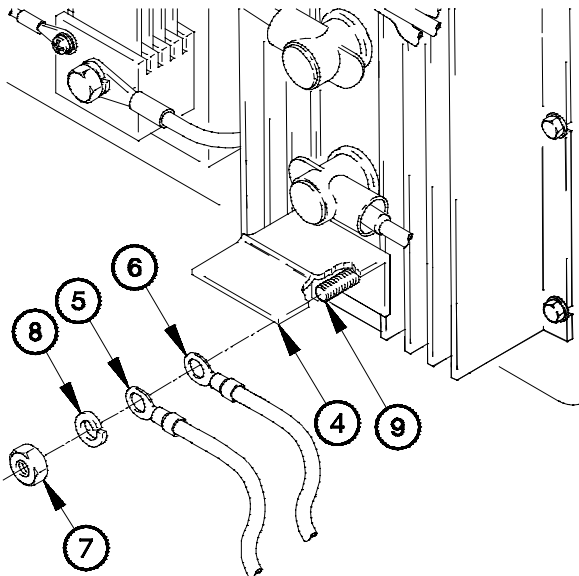
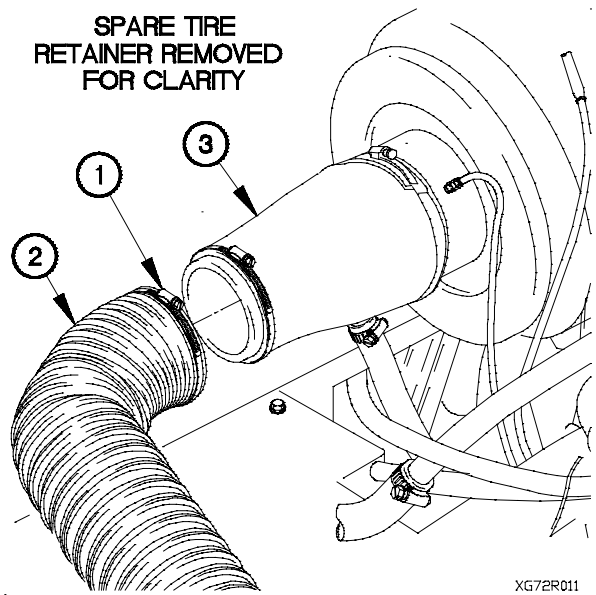

- (3) Lift terminal cover (4) on terminal lugs TL47 (5) and TL61 (6).

NOTE

Remove plastic cable ties as required.

- (4) Remove nut (7), lockwasher (8), and terminal lugs TL47 (5) and TL61 (6) from reverse polarity relay 12 VDC LOAD terminal (9). Discard lockwasher.

- (5) Lift dust boot (10) on terminal lug TL60 (11).
- (6) Remove self-locking nut (12), washer (13), insulation washer (14), and terminal lug TL60 (11) from alternator (15). Discard self-locking nut.
- (7) Remove dust boot (10) from 100 amp alternator to reverse polarity relay 12 vdc cable (16).

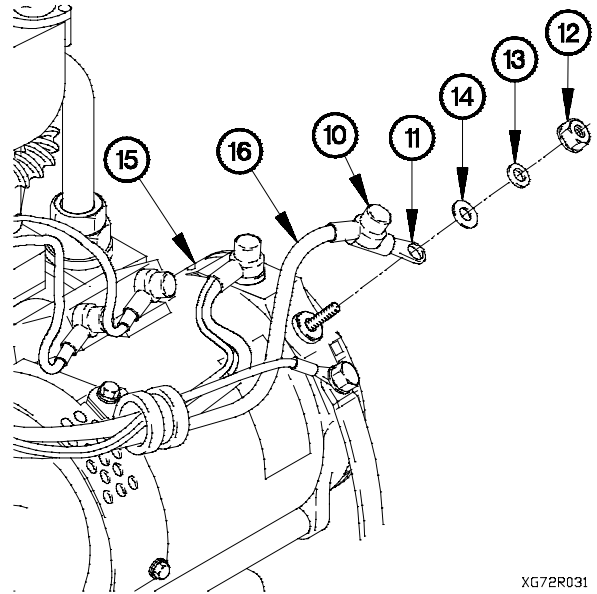

XG72R031

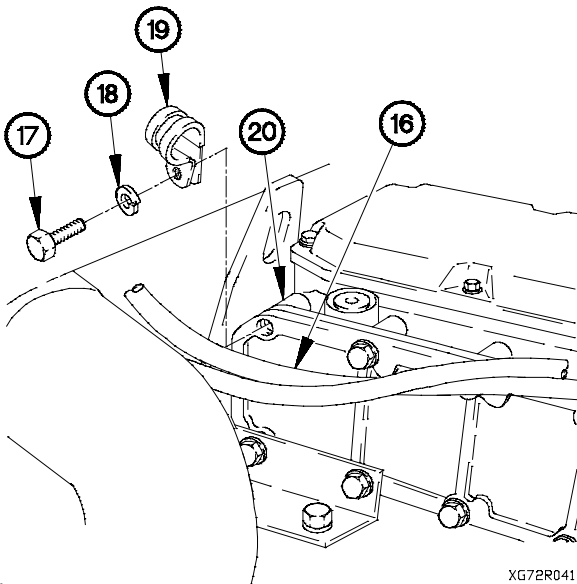

XG72R041

- (8) Remove three screws (17), washers (18), clamps (19), and 100 amp alternator to reverse polarity relay 12 vdc cable (16) from engine (20).
- (9) Remove three clamps (19) from 100 amp alternator to reverse polarity relay 12 vdc cable (16).

b. Installation.

- (1) Install three clamps (1) on 100 amp alternator to reverse polarity relay 12 vdc cable (2).

NOTE

Install plastic cable ties as required.

- (2) Position 100 amp alternator to reverse polarity relay 12 vdc cable (2) on engine (3) with three clamps (1), washers (4), and screws (5).
- (3) Tighten three screws (5) to 22-27 lb-ft (31-37 N·m).

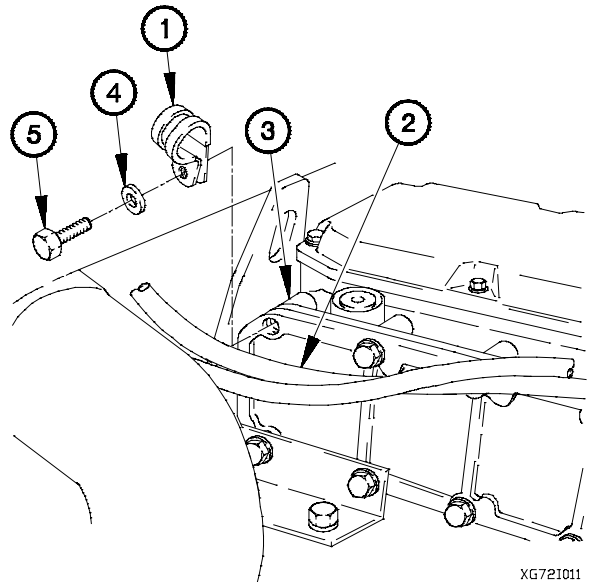

XG72I011

7-72. 100 AMP ALTERNATOR TO REVERSE POLARITY RELAY 12 VDC CABLE REPLACEMENT (CONT)

(4) Install dust boot (6) on 100 amp alternator to reverse polarity relay 12 vdc cable (2).

CAUTION

Insulation washer must be installed with flat side up. Failure to comply may result in damage to equipment.

(5) Position terminal lug TL60 (7) on alternator (8) with insulator washer (9), washer (10) and self-locking nut (11).

(6) Tighten self-locking nut (11) to 40 lb-in. (5 N·m).

(7) Position dust boot (6) on terminal lug TL60 (7).

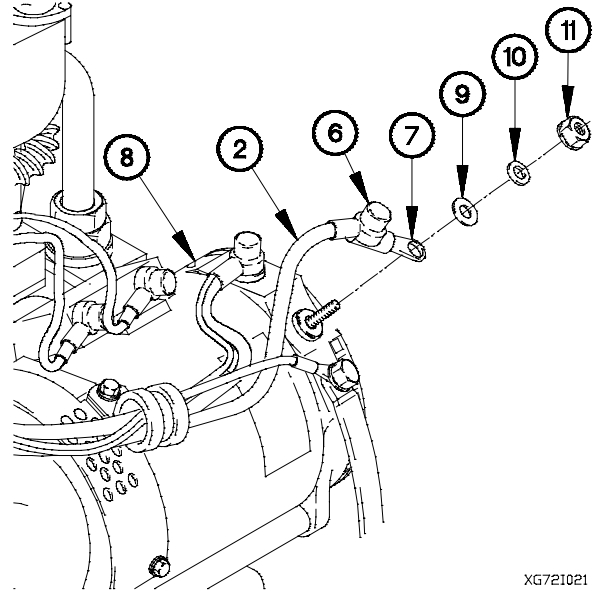

XG721021

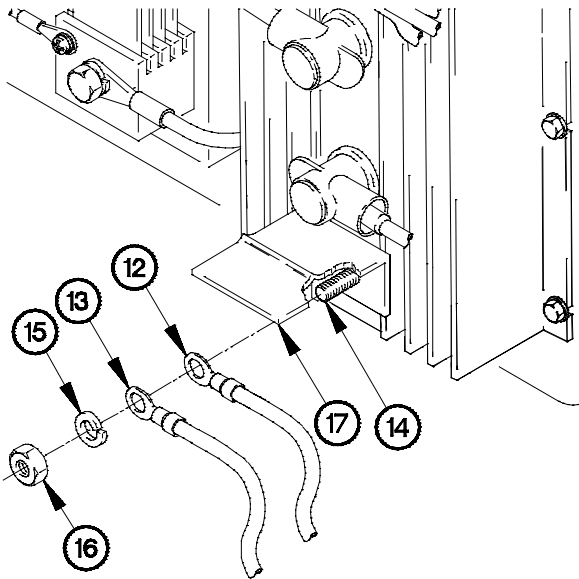

XG721031

(8) Position terminal lugs TL61 (12) and TL47 (13) on reverse polarity relay 12 VDC LOAD terminal (14) with lockwasher (15) and nut (16).

(9) Tighten nut (16) to 120-144 lb-in. (14-16 N·m).

(10) Position terminal cover (17) on terminal lugs TL47 (13) and TL61 (12).

(11) Position turbocharger intake hose (18) on intake air cleaner boot (19) with clamp (20).

(12) Tighten clamp (20) to 36-48 lb-in. (4-5 N·m).

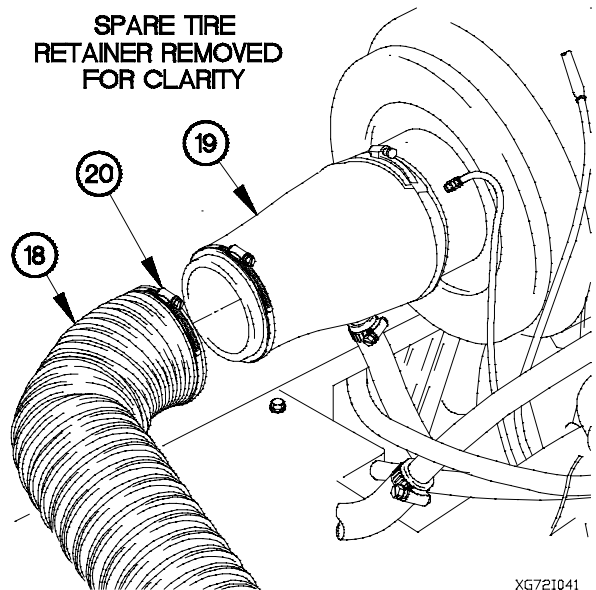

XG721041

c. Follow-On Maintenance.

- (1) Connect batteries (para 7-57).
- (2) Raise spare tire (TM 9-2320-366-10-2).
- (3) Start engine (TM 9-2320-366-10-1).
- (4) Check VOLTS gage for charge indication (TM 9-2320-366-10-1).
- (5) Shut down engine (TM 9-2320-366-10-1).

End of Task.

7-73. 100 AMP ALTERNATOR TO REVERSE POLARITY RELAY 24 VDC CABLE REPLACEMENT

This task covers:

- a. Removal
- b. Installation
- c. Follow-On Maintenance

INITIAL SETUP

Equipment Conditions

- Spare tire lowered (TM 9-2320-366-10-2).
- Cab raised (TM 9-2320-366-10-1).
- Batteries disconnected (para 7-57).

Tools and Special Tools

- Tool Kit, Genl Mech (Item 46, Appendix C)
- Wrench, Torque, 0-175 lb-ft (Item 58, Appendix C)
- Wrench, Torque, 0-200 lb-in. (Item 59, Appendix C)
- Socket Set, Socket Wrench (Item 34, Appendix C)

Materials/Parts

- Dispenser, Pressure Sensitive Adhesive Tape (Item 20, Appendix D)
- Ties, Cable, Plastic (Item 69, Appendix D)
- Lockwasher (Item 96, Appendix G)
- Nut, Self-Locking (Item 143, Appendix G)

a. Removal.

- (1) Loosen clamp (1) on turbocharger intake hose (2).
- (2) Remove turbocharger intake hose (2) from intake air cleaner boot (3).

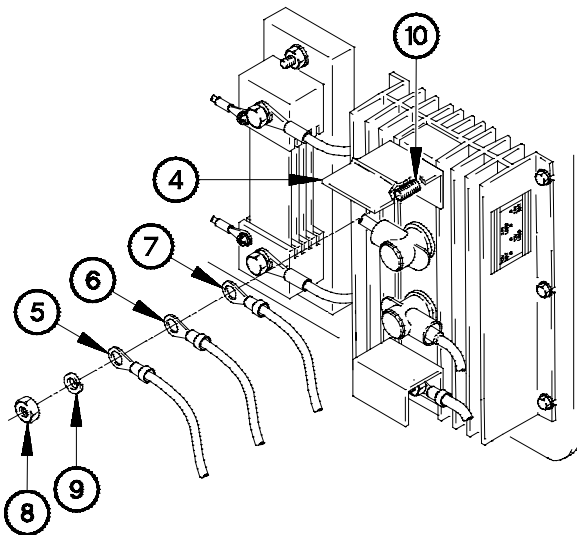
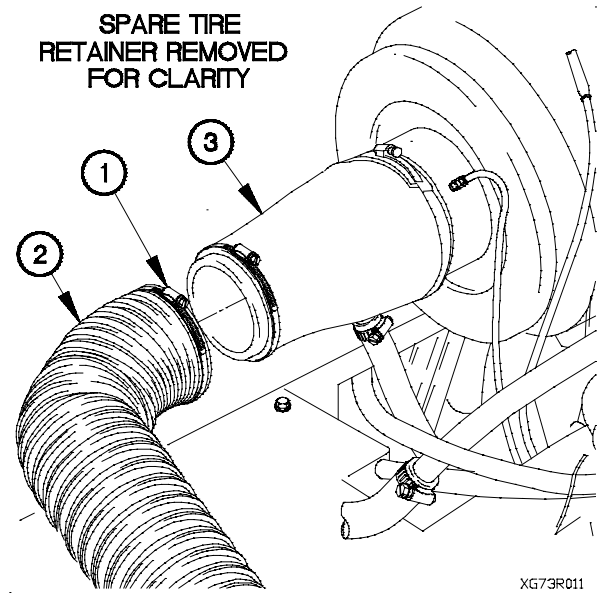

- (3) Lift terminal cover (4) on terminal lugs TL1 (5), TL36 (6), and TL37 (7).

NOTE

Remove plastic cable ties as required.

- (4) Remove nut (8), lockwasher (9), and terminal lugs TL1 (5), TL36 (6), and TL37 (7) from reverse polarity relay 24 VDC LOAD terminal (10). Discard lockwasher.

- (5) Lift dust boot (11) on terminal lugs TL2 (12) and TL6 (13).
- (6) Remove self-locking nut (14), washer (15), insulation washer (16), and terminal lugs TL2 (12) and TL6 (13) from alternator (17). Discard self-locking nut.
- (7) Remove 100 amp alternator to reverse polarity relay 24 vdc cable (18) from dust boot (11).

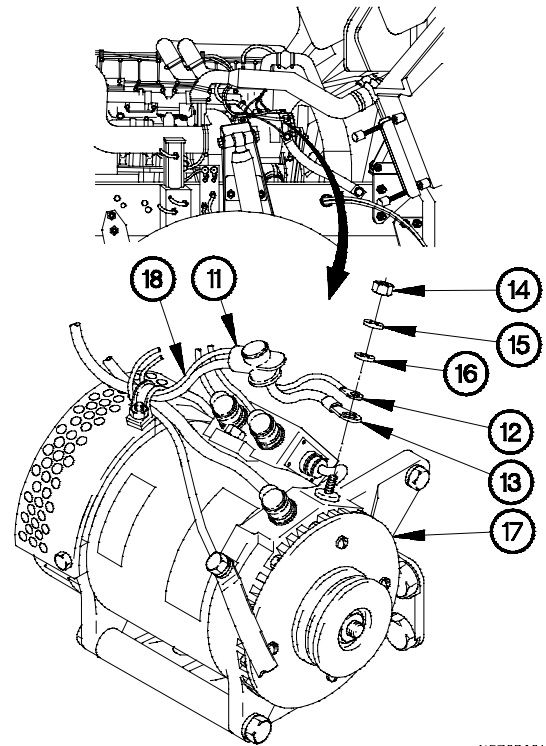

XG73R031

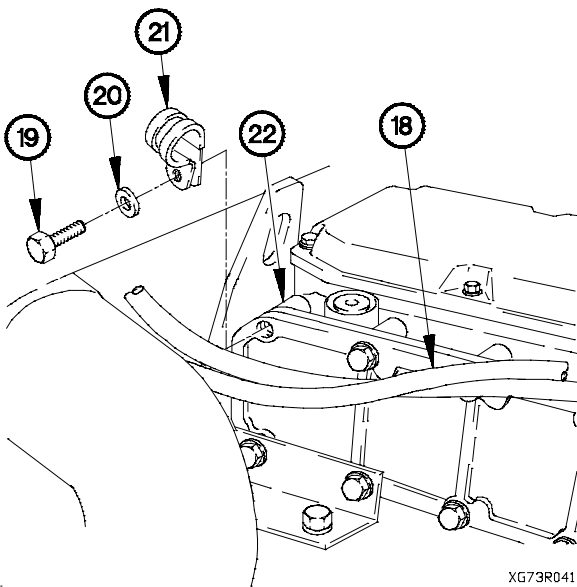

XG73R041

- (8) Remove three screws (19), washers (20), clamps (21), and 100 amp alternator to reverse polarity relay 24 vdc cable (18) from engine (22).
- (9) Remove three clamps (21) from 100 amp alternator to reverse polarity relay 24 vdc cable (18).

7-73. 100 AMP ALTERNATOR TO REVERSE POLARITY RELAY 24 VDC CABLE REPLACEMENT (CONT)

b. Installation.

- (1) Install three clamps (1) on 100 amp alternator to reverse polarity relay 24 vdc cable (2).

NOTE

Install plastic cable ties as required.

- (2) Position 100 amp alternator to reverse polarity relay 24 vdc cable (2) on engine (3) with three clamps (1), washers (4), and screws (5).
- (3) Tighten three screws (5) to 22-27 lb-ft (31-37 N·m).

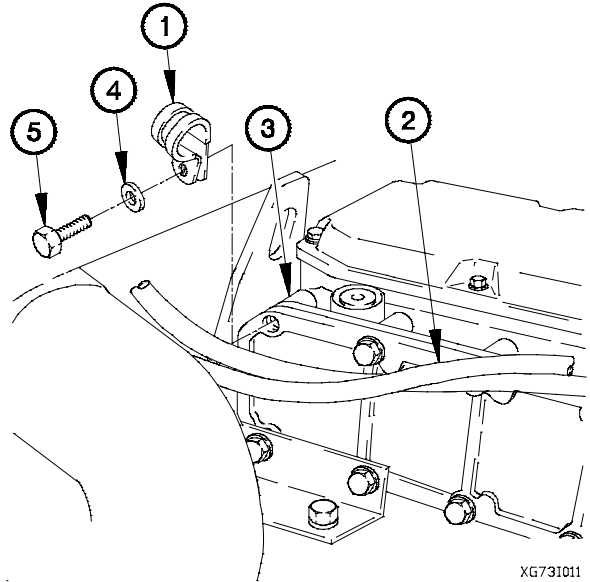

- (4) Install 100 amp alternator to reverse polarity relay 24 vdc cable (2) in dust boot (6).

CAUTION

Insulation washer must be installed with flat side up. Failure to comply may result in damage to equipment.

- (5) Position terminal lugs TL6 (7) and TL2 (8) on alternator (9) with insulation washer (10), washer (11) and self-locking nut (12).
- (6) Tighten self-locking nut (12) to 40 lb-in. (5 N·m).
- (7) Position dust boot (6) on terminal lugs TL2 (8) and TL6 (7).

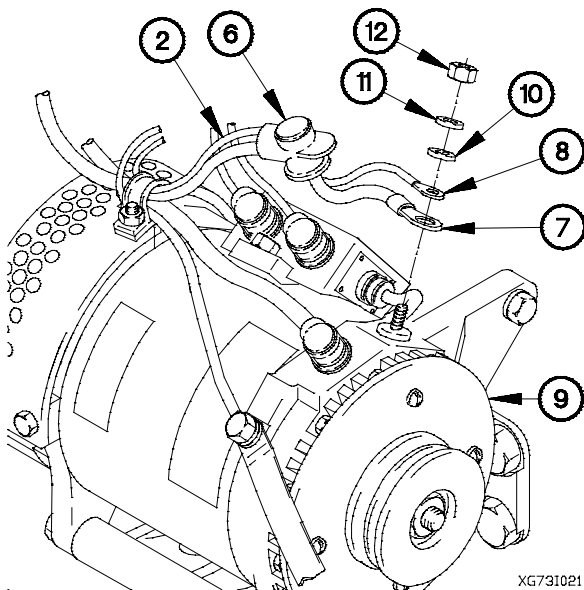

- (8) Position terminal lugs TL37 (13), TL36 (14), and TL1 (15) on reverse polarity relay 24 VDC LOAD terminal (16) with lockwasher (17) and nut (18).
- (9) Tighten nut (18) to 120-144 lb-in. (14-16 N-m).
- (10) Position terminal cover (19) on terminal lugs TL1 (15), TL36 (14), and TL37 (13).

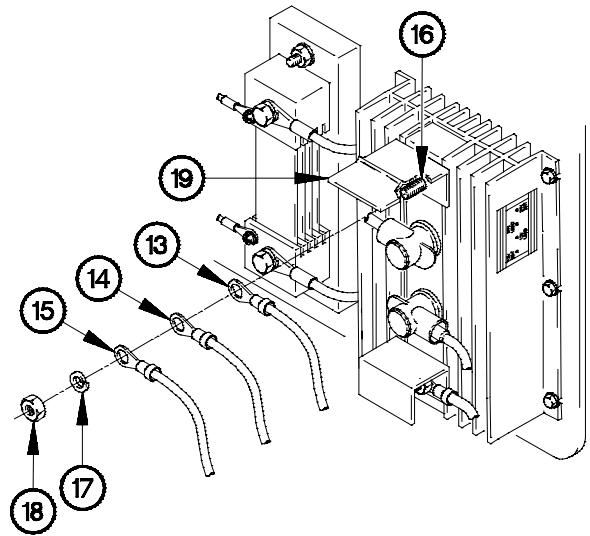

XG73I031

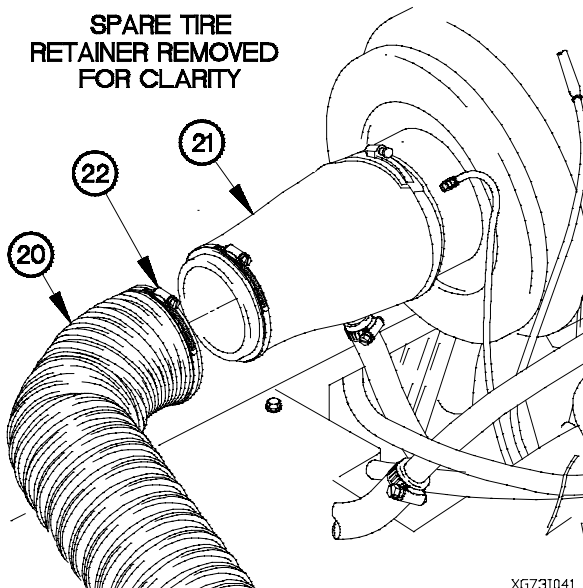

XG73I041

- (11) Position turbocharger intake hose (20) on intake air cleaner boot (21) with clamp (22).
- (12) Tighten clamp (22) to 36-48 lb-in. (4-5 N-m).

c. Follow-On Maintenance.

- (1) Connect batteries (para 7-57).
- (2) Raise spare tire (TM 9-2320-366-10-2).
- (3) Start engine (TM 9-2320-366-10-1).
- (4) Check VOLTS gage for charge indication (TM 9-2320-366-10-1).
- (5) Shut down engine (TM 9-2320-366-10-1).

End of Task.

7-74. BATTERY TO 100 AMP REVERSE POLARITY RELAY 12 VDC CABLE REPLACEMENT	
This task covers:	
<ul style="list-style-type: none"> a. Removal b. Installation 	<ul style="list-style-type: none"> c. Follow-On Maintenance
INITIAL SETUP	
<p>Equipment Conditions Spare tire lowered (TM 9-2320-366-10-2). Cab raised (TM 9-2320-366-10-1). Batteries disconnected (para 7-57).</p> <p>Tools and Special Tools Tool Kit, Genl Mech (Item 46, Appendix C) Wrench, Torque, 0-200 lb-in. (Item 59, Appendix C) Socket Set, Socket Wrench (Item 34, Appendix C)</p>	<p>Materials/Parts Ties, Cable, Plastic (Item 63, Appendix C) Lockwasher (Item 96, Appendix G)</p>

a. Removal.

- (1) Lift terminal cover (1) on terminal lugs TL61 (2) and TL47 (3).

NOTE

Remove plastic cable ties as required.

- (2) Remove nut (4), lockwasher (5), and terminal lugs TL61 (2) and TL47 (3) from 100 amp reverse polarity relay 12 VDC BAT terminal (6). Discard lockwasher.

NOTE

Note routing of 100 amp reverse polarity relay 12 vdc cable prior to removal.

- (3) Remove battery to 100 amp reverse polarity relay 12 vdc cable (7) from vehicle.

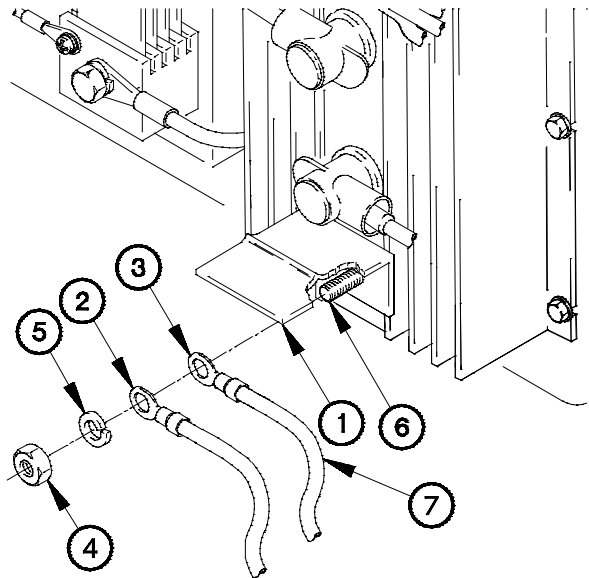

XG74R011

b. Installation.**NOTE**

Install plastic cable ties as required.

- (1) Position battery to 100 amp reverse polarity relay 12 vdc cable (1) on vehicle.
- (2) Position terminal lugs TL47 (2) and TL61 (3) on 100 amp reverse polarity relay 12 VDC BAT terminal (4) with lockwasher (5) and nut (6).
- (3) Tighten nut (6) to 120-144 lb-in. (14-16 N·m).
- (4) Position terminal cover (7) on terminal lugs TL47 (2) and TL61 (3).

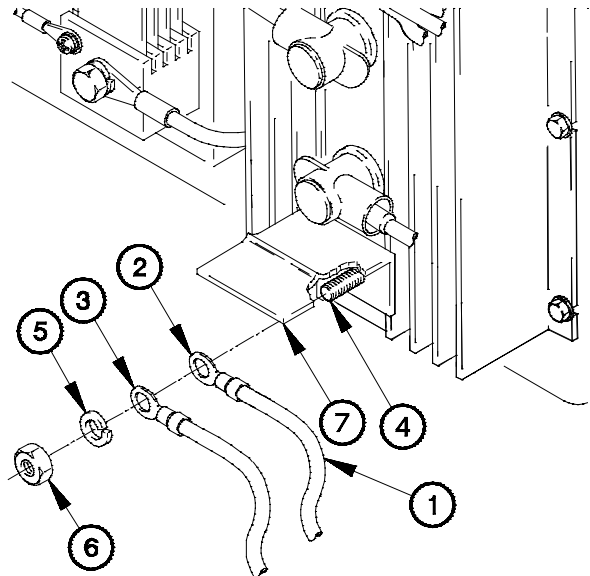

XG741011

c. Follow-On Maintenance.

- (1) Raise spare tire (TM 9-2320-366-10-2).
- (2) Connect batteries (para 7-57).
- (3) Start engine (TM 9-2320-366-10-1).
- (4) Check VOLTS gage for charge indication (TM 9-2320-366-10-1).
- (5) Shut down engine (TM 9-2320-366-10-1).

End of Task.

7-75. BATTERY TO 100 AMP REVERSE POLARITY RELAY 24 VDC CABLE REPLACEMENT

This task covers:

- a. Removal
- b. Installation
- c. Follow-On Maintenance

INITIAL SETUP

Equipment Conditions

- Spare tire lowered (TM 9-2320-366-10-2).
- Cab raised (TM 9-2320-366-10-1).
- Batteries disconnected (para 7-57).

Materials/Parts

- Lockwasher (Item 96, Appendix G)

Tools and Special Tools

- Tool Kit, Genl Mech (Item 46, Appendix C)
- Wrench, Torque, 0-200 lb-in. (Item 59, Appendix C)
- Socket Set, Socket Wrench (Item 36, Appendix C)
- Goggles, Industrial (Item 15, Appendix C)

a. Removal.

WARNING

Remove rings, bracelets, watches, necklaces, and any other jewelry before working around vehicle. Jewelry can catch on equipment and cause injury or short across electrical circuit and cause severe burns or electrical shock. Batteries can explode from a spark. Battery acid is harmful to skin and eyes. Always wear eye protection when working with batteries. Failure to comply may result in injury to personnel.

- (1) Remove nut (1) and terminal lugs TL39 (2) and TL10 (3) from battery 24 vdc cable (4).

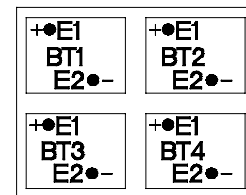

BATTERY INSTALLATION DIAGRAM

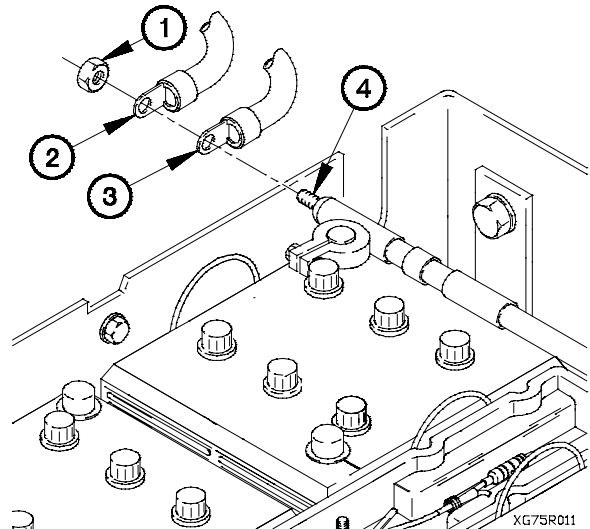

- (2) Loosen clamp (5) on turbocharger intake hose (6).
- (3) Remove turbocharger intake hose (6) from intake air cleaner boot (7).

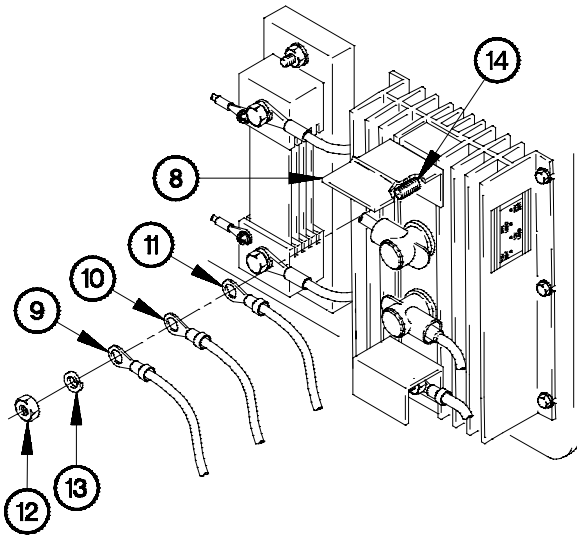
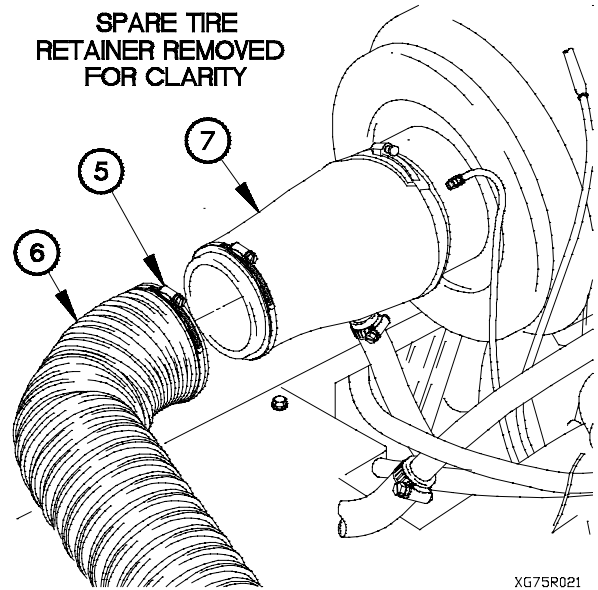

- (4) Lift terminal cover (8) on terminal lugs TL1 (9), TL36 (10), and battery to 100 amp reverse polarity relay 24 vdc cable terminal lug TL37 (11).
- (5) Remove nut (12), lockwasher (13), terminal lugs TL1 (9), TL36 (10), and battery to 100 amp reverse polarity relay 24 vdc cable terminal lug TL37 (11) from 100 amp reverse polarity relay 24 VDC BAT terminal (14). Discard lockwasher.

b. Installation.

- (1) Position battery to 100 amp reverse polarity relay 24 vdc cable terminal lug TL37 (1) and terminal lugs TL36 (2) and TL1 (3) on 100 amp reverse polarity relay 24 VDC BAT terminal (4) with lockwasher (5) and nut (6).
- (2) Tighten nut (6) to 120-144 lb-in. (14-16 N-m).
- (3) Position terminal cover (7) on terminal lugs TL1 (3), TL36 (2), and battery to 100 amp reverse polarity relay 24 vdc cable terminal lug TL37 (1).

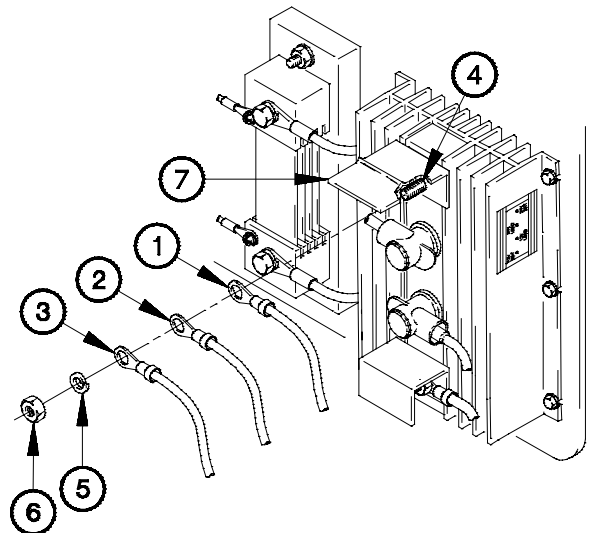

7-75. BATTERY TO 100 AMP REVERSE POLARITY RELAY 24 VDC CABLE REPLACEMENT (CONT)

- (4) Position turbocharger intake hose (8) on intake air cleaner boot (9) with clamp (10).
- (5) Tighten clamp (10) to 36-48 lb-in. (4-5 N·m).

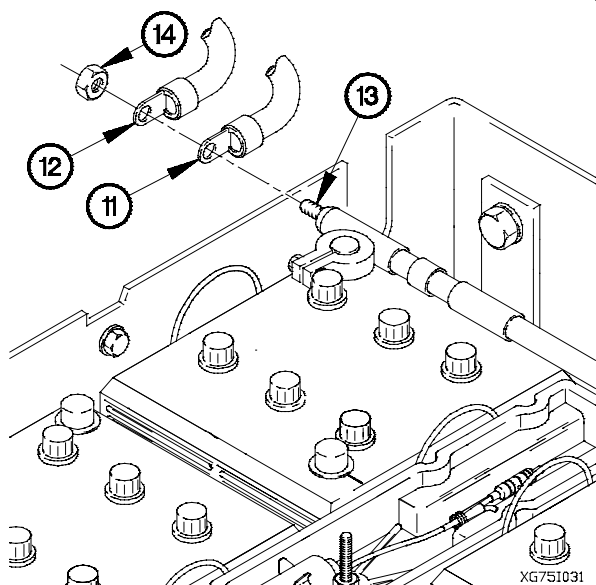
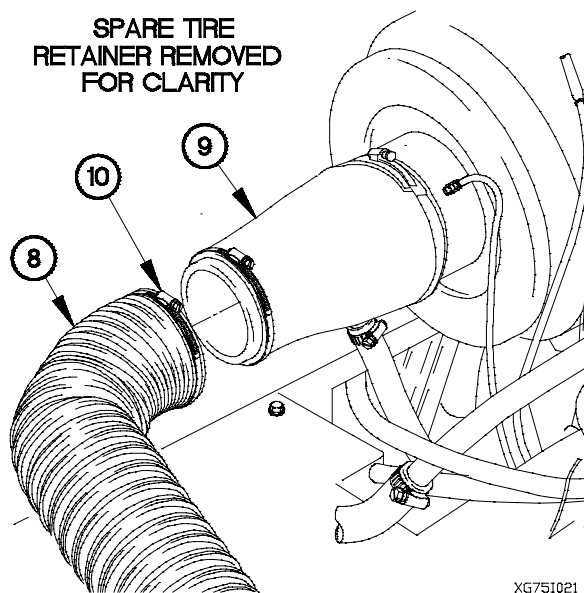

- (6) Install terminal lugs TL10 (11) and TL39 (12) on battery 24 vdc cable (13) with nut (14).

c. Follow-On Maintenance.

- (1) Connect batteries (para 7-57).
- (2) Raise spare tire (TM 9-2320-366-10-2).
- (3) Start engine (TM 9-2320-366-10-1).
- (4) Check VOLTS gage for 24 vdc (TM 9-2320-366-10-1).
- (5) Shut down engine (TM 9-2320-366-10-1).

End of Task.

7-76. BATTERY TO SHUNT CABLE ASSEMBLY REPLACEMENT	
This task covers:	
a. Removal b. Installation	c. Follow-On Maintenance
INITIAL SETUP	
Equipment Conditions Spare tire lowered (TM 9-2320-366-10-2). Cab raised (TM 9-2320-366-10-1). Batteries disconnected (para 7-57).	Materials/Parts Lockwasher (Item 87, Appendix G)
Tools and Special Tools Tool Kit, Genl Mech (Item 46, Appendix C) Wrench, Torque, 0-200 lb-in. (Item 59, Appendix C) Socket Set, Socket Wrench (Item 34, Appendix C)	

a. Removal.

- (1) Loosen clamp (1) on turbocharger intake hose (2).
- (2) Remove turbocharger intake hose (2) from intake air cleaner boot (3).

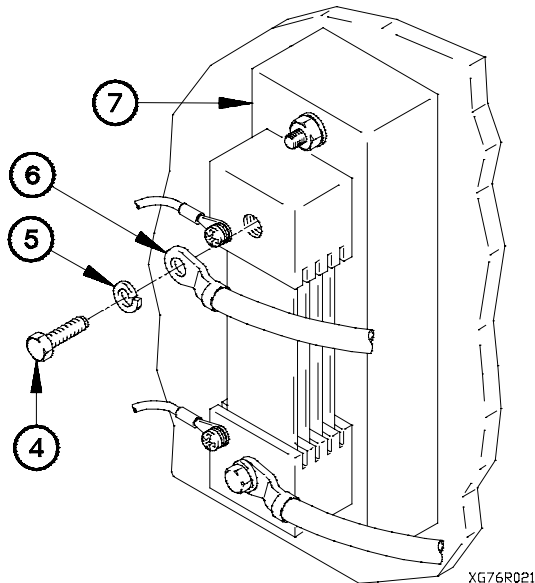
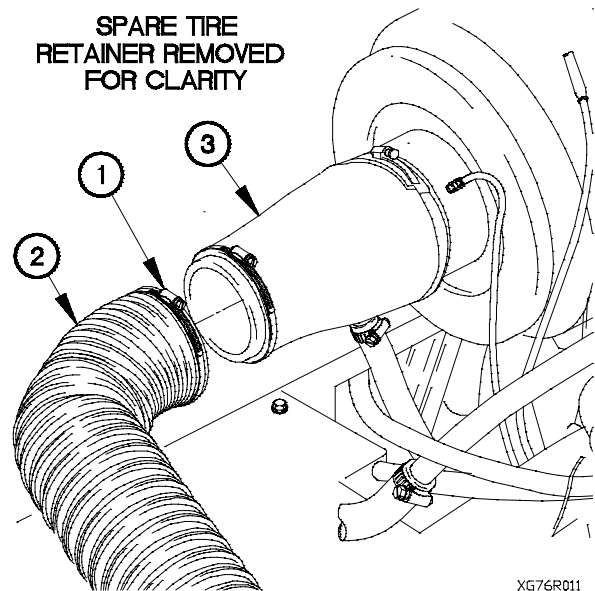

- (3) Remove screw (4), lockwasher (5), and terminal lug TL52 (6) from shunt (7). Discard lockwasher.

7-76. BATTERY TO SHUNT CABLE ASSEMBLY REPLACEMENT (CONT)

b. Installation.

- (1) Install terminal lug TL52 (1) on shunt (2) with lockwasher (3) and screw (4).

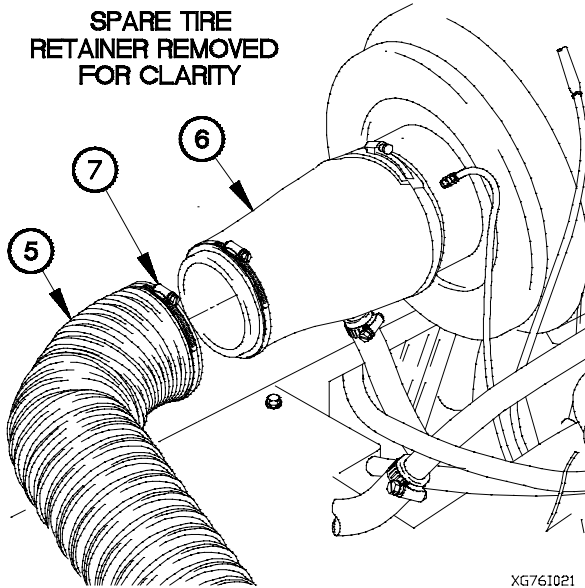
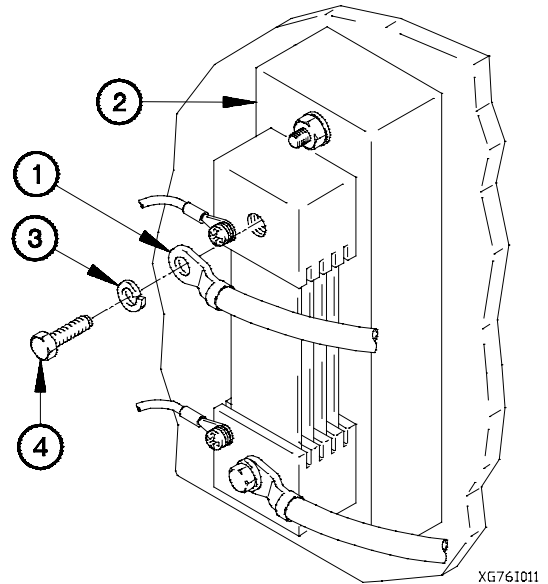

- (2) Position turbocharger intake hose (5) on intake air cleaner boot (6) with clamp (7).
- (3) Tighten clamp (7) to 36-48 lb-in. (4-5 N·m).

c. Follow-On Maintenance.

- (1) Connect batteries (para 7-57).
- (2) Raise spare tire (TM 9-2320-366-10-2).
- (3) Start engine (TM 9-2320-366-10-1).
- (4) Shut down engine (TM 9-2320-366-10-1).

End of Task.

7-77. BATTERY TO STARTER CABLE ASSEMBLY REPLACEMENT

This task covers:

- a. Removal
- b. Installation
- c. Follow-On Maintenance

INITIAL SETUP

Equipment Conditions

Batteries disconnected (para 7-57).
 Cab raised (TM 9-2320-366-10-1).

Tools and Special Tools

Tool Kit, Genl Mech (Item 46, Appendix C)
 Wrench, Torque, 0-175 lb-ft (Item 58, Appendix C)

Materials/Parts

Dispenser, Pressure Sensitive Adhesive Tape (Item 20, Appendix D)
 Ties, Cable, Plastic (Item 69, Appendix D)
 Adhesive (Item 8, Appendix D)
 Nut, Self-Locking (2) (Item 150, Appendix G)

Personnel Required

(2)

a. Removal.



Remove rings, bracelets, watches, necklaces, and any other jewelry before working around vehicle. Jewelry can catch on equipment and cause injury or short across electrical circuit and cause severe burns or electrical shock. Batteries can explode from a spark. Battery acid is harmful to skin and eyes. Always wear eye protection when working with batteries. Failure to comply may result in injury to personnel.

NOTE

- Note routing of battery to starter cable assembly prior to removal.
- Tag wires and connection points prior to disconnecting.

- (1) Remove nut (1) and terminal lugs TL39 (2) and TL10 (3) from battery 24 vdc cable (4).

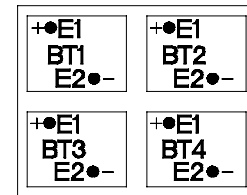

BATTERY INSTALLATION DIAGRAM

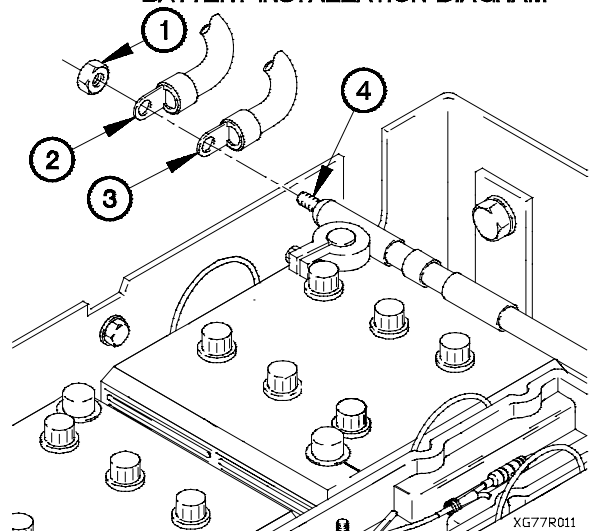

XG77R011

7-77. BATTERY TO STARTER CABLE ASSEMBLY REPLACEMENT (CONT)

NOTE

- Both clamps are removed the same way. One shown.
 - Remove plastic cable ties as required.
- (2) Remove self-locking nut (5), screw (6), battery to starter cable assembly (7), and clamp (8) from frame rail (9). Discard self-locking nut.

NOTE

Step (3) requires the aid of an assistant.

- (3) Perform step (2) on remaining clamp.
- (4) Remove two clamps (8) from battery to starter cable assembly (7).

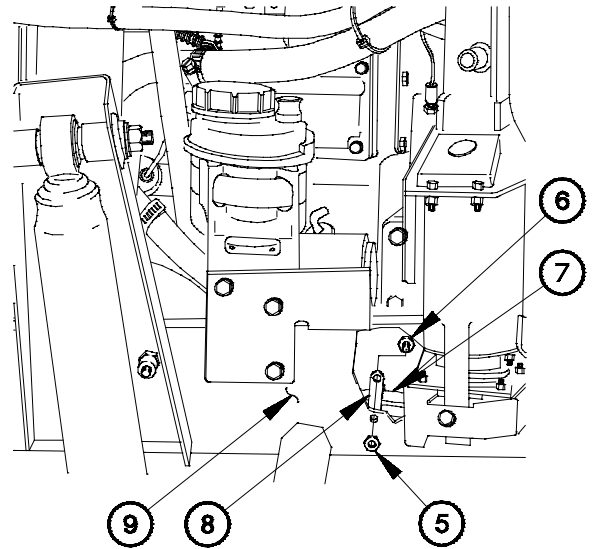

XG77R021

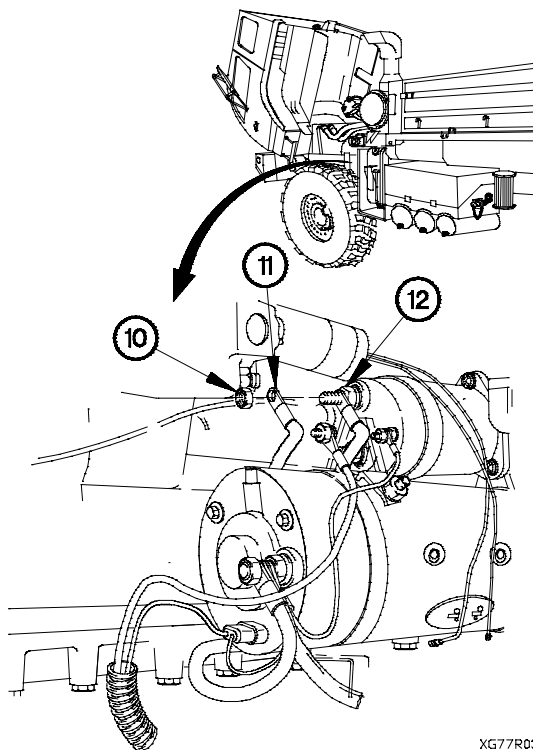

XG77R03B

- (5) Remove adhesive, nut (10), and terminal lug TL12 (11) from starter solenoid (12).

b. Installation.

- (1) Position terminal lug TL12 (1) on starter solenoid (2) with nut (3).
- (2) Tighten nut (3) to 15-20 lb-ft (20-27 N-m).

WARNING

Adhesives, solvents, and sealing compounds can burn easily, can give off harmful vapors, and are harmful to skin and clothing. Keep away from open fire and use in a well-ventilated area. If adhesive, solvent, or sealing compound gets on skin or clothing, wash immediately with soap and water. Failure to comply may result in injury to personnel.

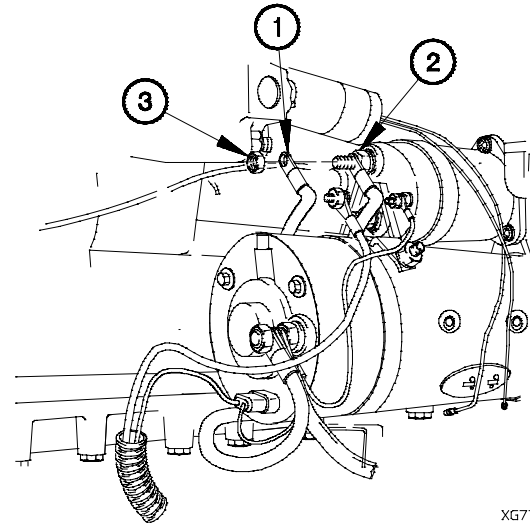

XG77101B

- (3) Apply adhesive to terminal lug TL12 (1) on starter solenoid (2).

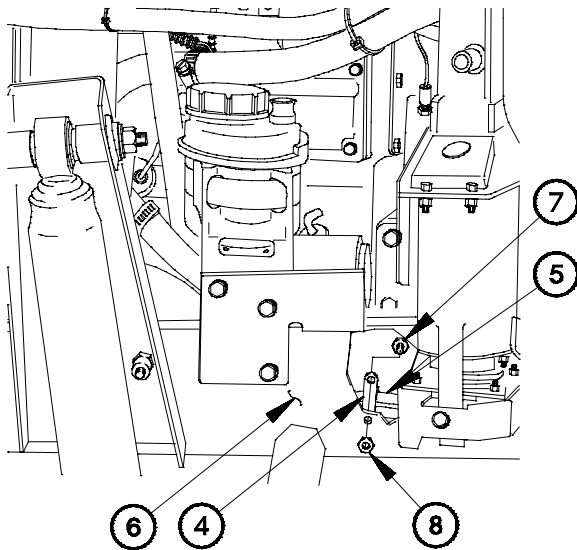

XG771021

NOTE

Both clamps are installed the same way. One shown.

- (4) Install two clamps (4) on battery to starter cable assembly (5).

NOTE

Steps (5) through (7) require the aid of an assistant.

- (5) Position battery to starter cable assembly (5) on frame rail (6) with clamp (4), screw (7) and self-locking nut (8).
- (6) Perform Step (5) on remaining clamp.

NOTE

Install plastic cable ties as required.

- (7) Tighten two self-locking nuts (8) to 97-124 lb-in. (11-14 N-m).

7-77. BATTERY TO STARTER CABLE ASSEMBLY REPLACEMENT (CONT)

(8) Install terminal lugs TL10 (9) and TL39 (10) on battery 24 vdc cable (11) with nut (12).

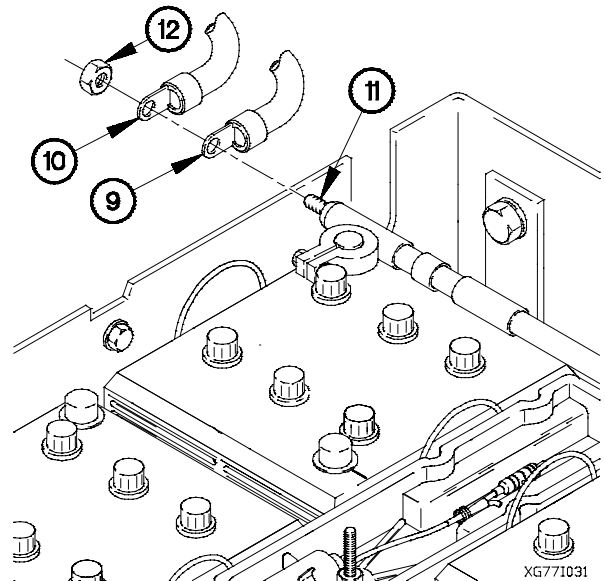

c. Follow-On Maintenance.

- (1) Lower cab (TM 9-2320-366-10-1).
- (2) Connect batteries (para 7-57).
- (3) Start engine (TM 9-2320-366-10-1).
- (4) Shut down engine (TM 9-2320-366-10-1).

End of Task.

7-78. CAB TO CHASSIS GROUND STRAP REPLACEMENT

This task covers:

- a. Removal
- b. Installation
- c. Follow-On Maintenance

INITIAL SETUP

Equipment Conditions

Batteries disconnected (para 7-57).

Tools and Special Tools

Tool Kit, Genl Mech (Item 46, Appendix C)
Wrench, Torque, 0-200 lb-in. (Item 58, Appendix C)

Tools and Special Tools (Cont)

Socket Set, Socket Wrench, (Item 35, Appendix C)

Materials/Parts

Ties, Cable, Plastic (Item 69, Appendix D)
Nut, Self-Locking (Item 167, Appendix G)
Lockwasher (Item 75, Appendix G)

a. Removal.

NOTE

Remove plastic cable ties as required.

- (1) Remove two screws (1) and washers (2) from front grille (3).
- (2) Remove screw (4) and washer (5) from front grille (3).
- (3) Remove front grille (3) from cab (6).

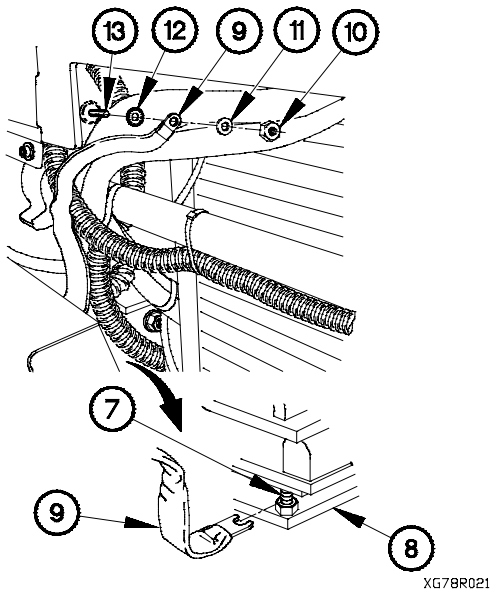
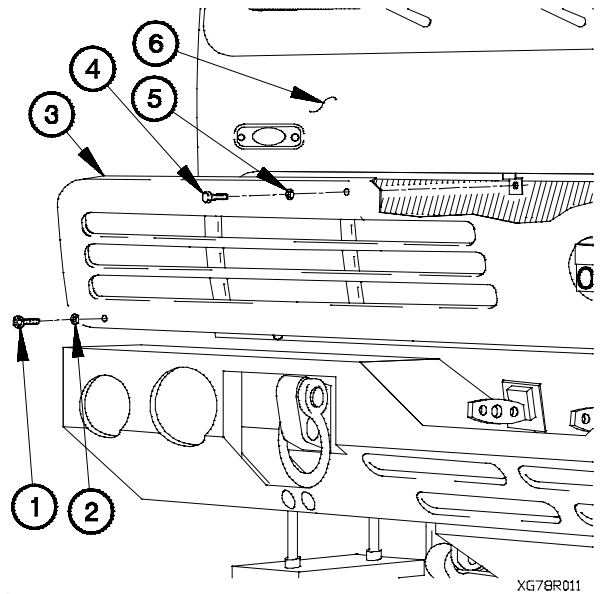

- (4) Loosen screw (7) in chassis (8) and remove cab to chassis ground cable (9).
- (5) Remove self-locking nut (10), washer (11), cab to chassis ground cable (9), and lockwasher (12) from stud (13). Discard self-locking nut and lockwasher.

7-78. CAB TO CHASSIS GROUND STRAP REPLACEMENT (CONT)

b. Installation.

- (1) Install cab to chassis ground cable (1) on stud (2) with lockwasher (3), washer (4), and self-locking nut (5).
- (2) Position cab to chassis ground cable (1) on chassis (6) and tighten screw (7).

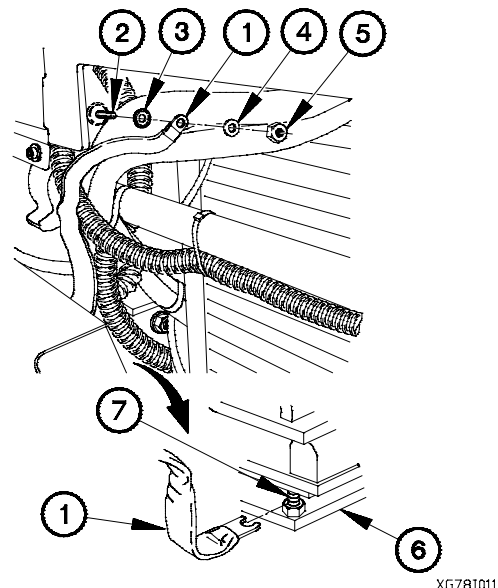

XG781011

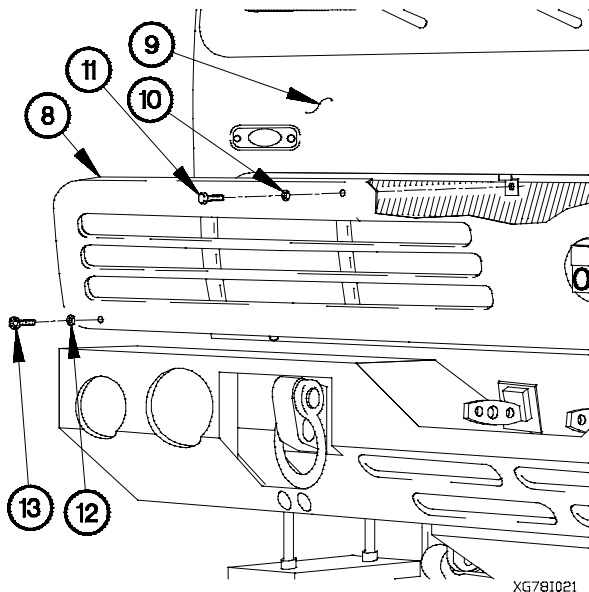

XG781021

- (3) Position front grille (8) on cab (9) with washer (10) and screw (11).
- (4) Position two washers (12) and screws (13) in front grille (8).
- (5) Tighten screw (11) to 48-60 lb-in. (5-7 N•m).
- (6) Tighten two screws (13) to 24 lb-in. (3 N•m).

c. Follow-On Maintenance.

- (1) Connect batteries (para 7-57).
- (2) Start engine (TM 9-2320-366-10-1).
- (3) Check VOLTS gage for charge indication (TM 9-2320-366-10-1).
- (4) Shut down engine (TM 9-2320-366-10-1).

End of Task.

7-79. M1084/M1086 CRANE POWER CONTROL CABLE ASSEMBLY REPLACEMENT**This task covers:**

- | | |
|---|--|
| <ul style="list-style-type: none"> a. Removal b. Installation | <ul style="list-style-type: none"> c. Follow-On Maintenance |
|---|--|

INITIAL SETUP**Equipment Conditions**

- Batteries disconnected (para 7-57).
- Kick panel removed (para 16-3).

Tools and Special Tools

- Tool Kit, Genl Mech (Item 46, Appendix C)

Materials/Parts

- Dispenser, Pressure Sensitive Adhesive Tape (Item 20, Appendix D)
- Ties, Cable, Plastic (Item 69, Appendix D)
- Lockwasher (2) (Item 96, Appendix G)
- Washer, Spring (2) (Item 289, Appendix G)
- Washer, Spring (2) (Item 296, Appendix G)
- Nut, Self-Locking (19) (Item 154, Appendix G)

a. Removal.

- (1) Disconnect connector P171 (1) from crane junction box connector (2).

NOTE

- Remove plastic cable ties as required.
 - Tag terminal lugs and connection points prior to disconnecting.
- (2) Remove screw (3), terminal lugs TL67 (4), TL17 (5), TL69 (6), and lockwasher (7) from left taillight carrier (8). Discard lockwasher.

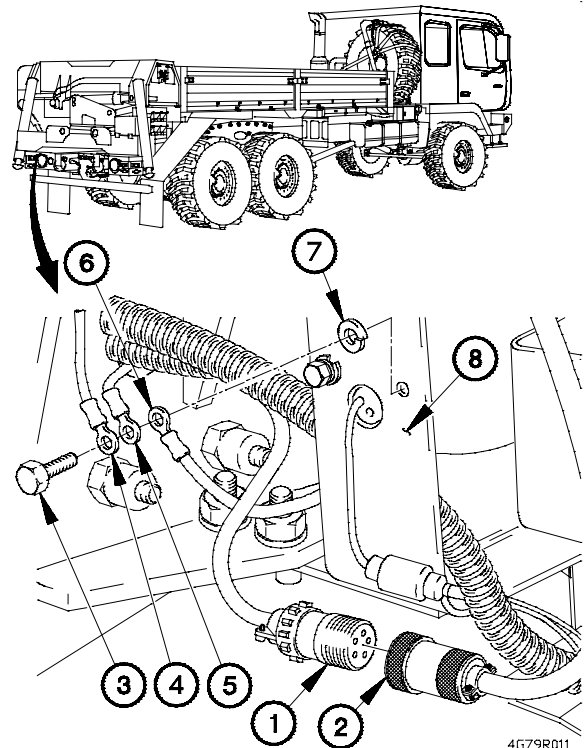

4G79R011

7-79. M1084/M1086 CRANE POWER CONTROL CABLE ASSEMBLY REPLACEMENT (CONT)

- (3) Remove dust cap (9) from connector P135 (10).
- (4) Remove nut (11), screw (12), spring washer (13), and lanyard (14) from left taillight carrier (8). Discard spring washer.
- (5) Remove nut (15), spring washer (16), and connector P135 (10) from left tail light carrier (8). Discard spring washer.

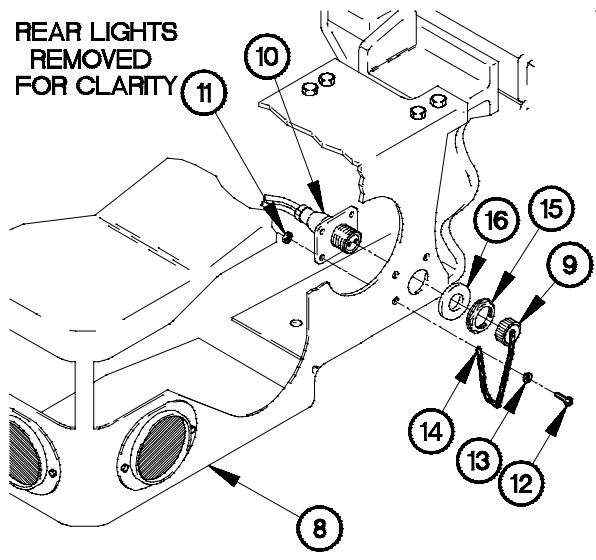

4G79R021

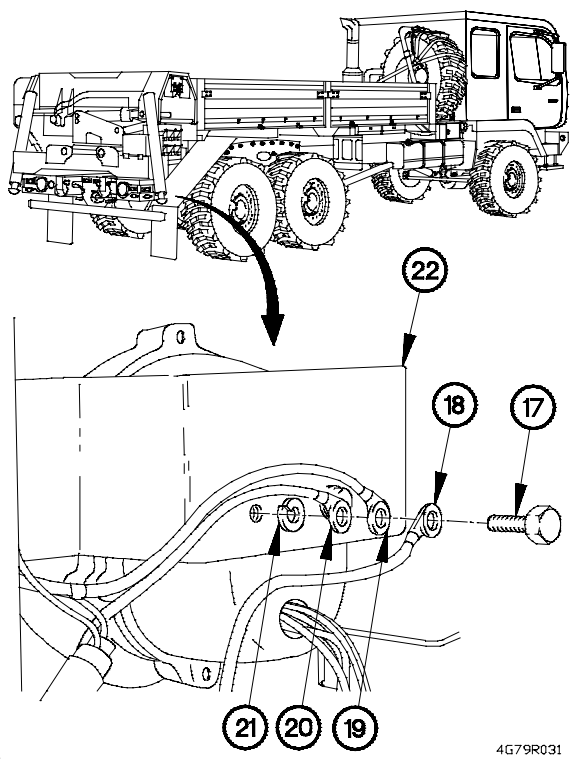

4G79R031

- (6) Remove screw (17), terminal lugs TL20 (18), TL21 (19), TL68 (20), and lockwasher (21) from right taillight carrier (22). Discard lockwasher.

- (7) Remove dust cap (23) from connector P136 (24).
- (8) Remove nut (25), screw (26), spring washer (27), and lanyard (28) from worklight connector bracket (29). Discard spring washer.
- (9) Remove nut (30), spring washer (31), and connector P136 (24) from worklight connector bracket (29). Discard spring washer.

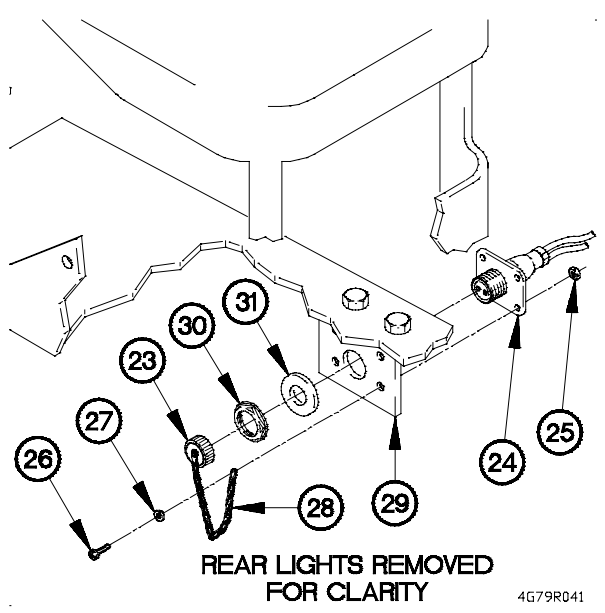

4G79R041

- (10) Remove 19 self-locking nuts (32), screws (33), and clamps (34) from right frame rail (35). Discard self-locking nuts.
- (11) Remove crane power control cable assembly (36) from 19 clamps (34).

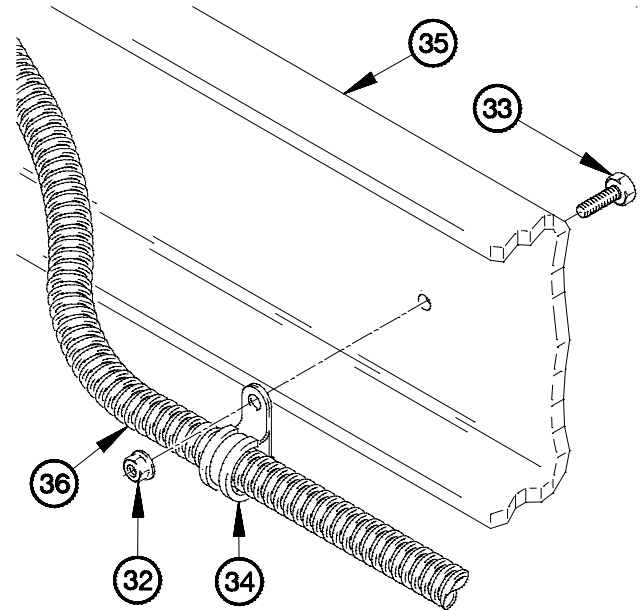

4g79r051

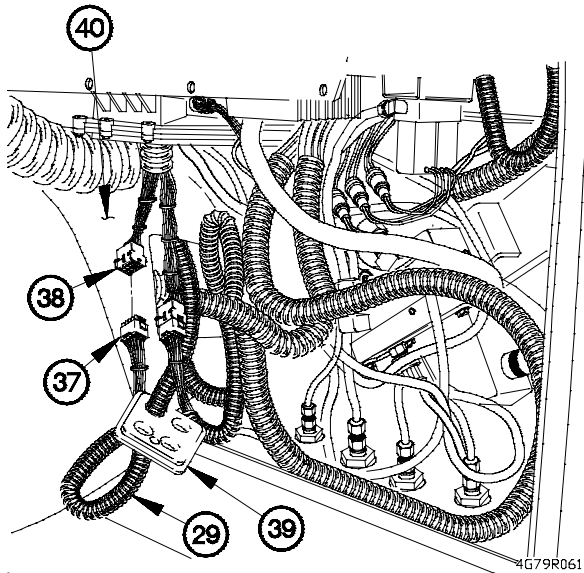

- (12) Disconnect connector P108 (37) from connector J108 (38).
- (13) Remove grommet (39) from cab (40).
- (14) Remove crane power control cable assembly (29) from grommet (39).
- (15) Remove crane power control cable assembly (29) from cab (40).

b. Installation.

- (1) Route crane power control cable assembly (1) inside cab (2).
- (2) Install crane power control cable assembly (1) in grommet (3).
- (3) Connect connector P108 (4) to connector J108 (5).

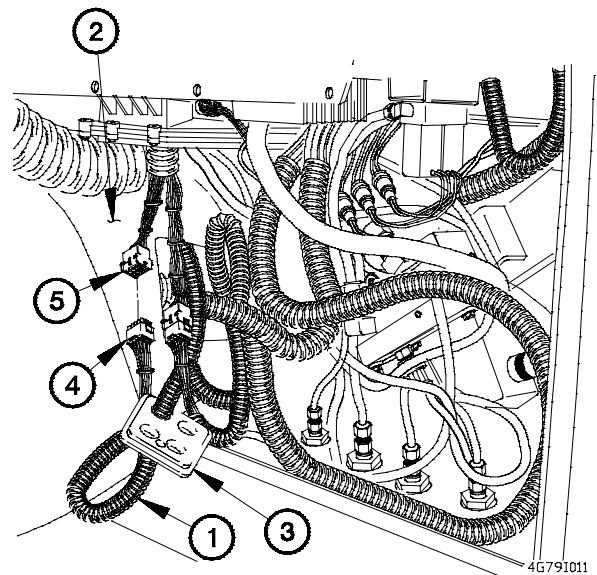

4G79I011

7-79. M1084/M1086 CRANE POWER CONTROL CABLE ASSEMBLY REPLACEMENT (CONT)

(4) Install crane power control cable assembly (1) in 19 clamps (6).

(5) Install 19 clamps (6) on right frame rail (7) with 19 screws (8) and self-locking nuts (9).

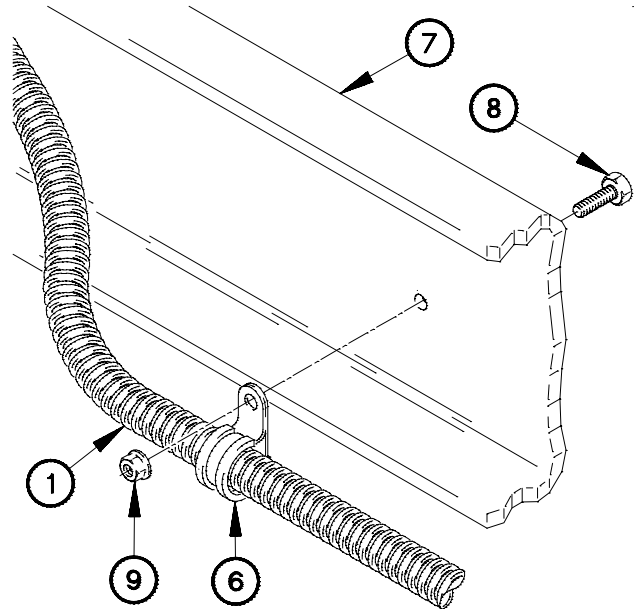

4g79i021

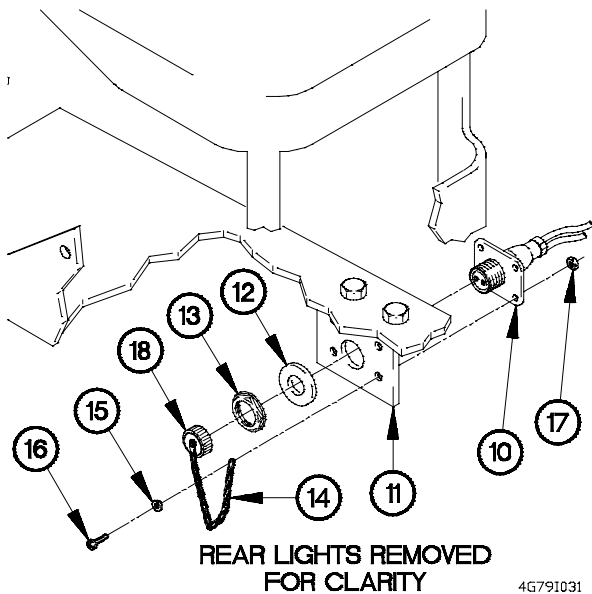

4G79I031

(6) Install connector P136 (10) in worklight connector bracket (11) with spring washer (12) and nut (13).

(7) Install lanyard (14) on worklight connector bracket (11) with spring washer (15), screw (16), and nut (17).

(8) Install dust cap (18) on connector P136 (10).

(9) Install terminal lugs TL68 (19), TL21 (20), and TL20 (21) on right taillight carrier (22) with lockwasher (23) and screw (24).

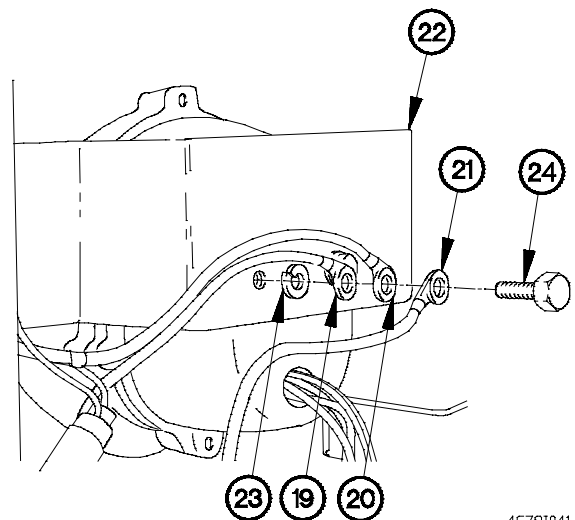

4G79I041

- (10) Install connector P135 (25) in left taillight carrier (26) with spring washer (27) and nut (28).
- (11) Install lanyard (29) on left taillight carrier (26) with spring washer (30), screw (31), and nut (32).
- (12) Install dust cap (33) on connector P135 (25).

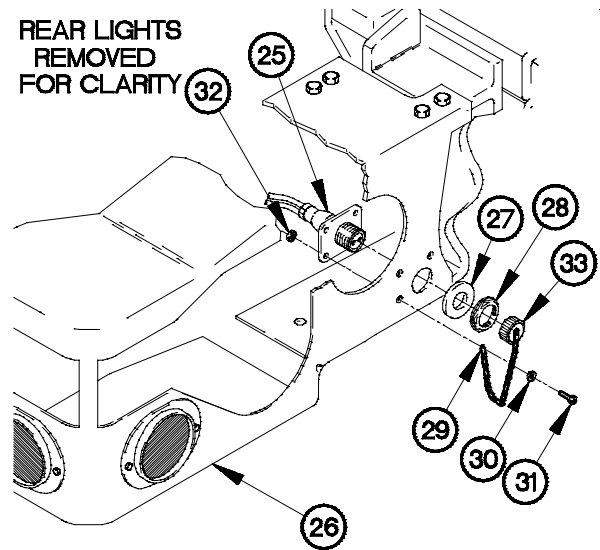

4G791051

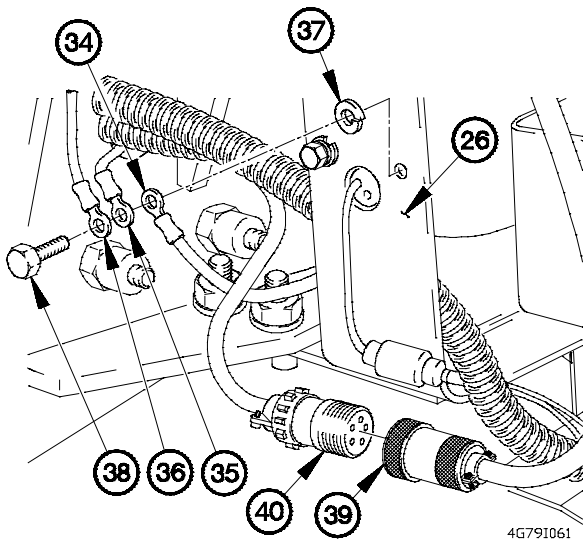

4G791061

- (13) Install terminal lugs TL69 (34), TL17 (35), and TL67 (36) on left taillight carrier (26) with lockwasher (37) and screw (38).
- (14) Connect crane junction box connector (39) to connector P171 (40).

c. Follow-On Maintenance.

- (1) Install kick panel (para 16-3).
- (2) Connect batteries (para 7-57).
- (3) Start engine (TM 9-2320-366-10-1).
- (4) Check MHC operation (TM 9-2320-366-10-1).
- (5) Shut down engine (TM 9-2320-366-10-1).

End of Task.

APPENDIX A REFERENCES

A-1. SCOPE

This appendix lists all forms, field manuals, technical manuals, and other publications referenced in this manual. Those publications that should be consulted for additional information about vehicle operations are also listed.

A-2. PUBLICATIONS INDEX

The following index should be consulted frequently for latest changes or revisions and for new publications relating to material covered in this technical manual.

Consolidated Index of Army Publications and Blank Forms DA Pam 25-30

A-3. FORMS

The following forms pertain to this manual. See DA Pam 25-30 for index of blank forms. See DA Pam 738-750, The Army Maintenance Management System (TAMMS), for instructions on the use of maintenance forms pertaining to this material.

Recommended Changes to DA Publications and Blank Forms DA Form 2028-2
 Equipment Inspection and Maintenance Worksheet DA Form 2404
 Maintenance Request DA Form 2407
 Equipment Control Record DA Form 2408-9
 Processing and Deprocessing Record of Shipping, Storage, and Issue of Vehicles and
 Spare Engines DD Form 1397
 Packaging Improvement Report DD Form 6
 Report of Item Discrepancy (ROID) SF 364
 Product Quality Deficiency Report SF 368

A-4. OTHER PUBLICATIONS

The following publications contain information pertinent to the MTV and associated equipment.

a. Safety.

First Aid for Soldiers FM 21-11
 Security of Tactical Wheeled Vehicles TB 9-2300-422-20
 Safety Inspection and Testing of Lifting Devices TB 43-0142

A-4. OTHER PUBLICATIONS (CONT)

b. MTV.

Direct Support and General Support Maintenance Manual for M1083 Series, 5-Ton, 6x6, Medium Tactical Vehicle (MTV) TM 9-2320-366-34

Hand Receipt Covering Contents of Components of End Item (COEI), Basic Issue Items (BII), and Additional Authorization List (AAL), for M1083 Series, 5-Ton, 6x6, Medium Tactical Vehicles (MTV) TM 9-2320-366-10-HR

Operator's Manual for M1083 Series, 5-Ton, 6x6, Medium Tactical Vehicle (MTV) TM 9-2320-366-10

Unit, Direct Support, and General Support Repair Parts and Special Tools List for M1083 Series, 5-Ton, 6x6, Medium Tactical Vehicle (MTV) TM 9-2320-366-24P

Warranty Program for M1083 Series, 5-Ton, 6x6, Medium Tactical Vehicle (MTV) TB 9-2300-366-15

c. General Vehicle Operation.

Army Motor Transport Units and Operations FM 55-30

Deleted

Manual for the Wheeled Vehicle Driver FM 21-305

Petroleum Tank Vehicle Operations FM 10-71

Safety Prevention of Motor Vehicle Accidents AR 385-557

Vehicle Recovery Operations FM 20-22

d. General Maintenance and Repair.

Army Oil Analysis Program TB 43-0211

Camouflage Pattern Painting FM 5-20

Charging System Troubleshooting DA Pam 750-33

Color, Marking, and Camouflage Painting of Military Vehicles TB 43-0209

Cooling Systems: Tactical Vehicles TM 750-254

Corrosion Prevention and Control Including Rustproofing Procedures for Tactical Vehicles and Trailers TB 43-0213

Description, Use, Bonding Techniques, and Properties of Adhesives TB ORD 1032

Equipment Improvement Report and Maintenance Digest: TACOM Equipment TB 43-0001-39-1

Equipment Improvement Report and Maintenance Summary TM 43-0143

Installation Instructions for Installation Kit, Electronic Equipment, MK-2700/VRC (NSN 5895-01-421-0814) (EIC: N/A) to Permit Installation of Radio Set AN/VRC-87/88/90 Series into M1078, M1080, M1081, M1083-M1086, M1088-M1094 and M1096 Family of Medium Tactical Vehicles TB 11-5820-890-20-101

Installation Instructions for Installation Kit, Electronic Equipment, MK-2715/VRC (NSN 5895-01-421-0812) (EIC: N/A) to Permit Installation of Radio Set AN/VRC-89/91/92 Series into M1078, M1080, M1081, M1083-M1086, M1088-M1094 and M1096 Family of Medium Tactical Vehicles TB 11-5820-890-20-92

Materials Used for Cleaning, Preserving, Abrading, and Cementing Ordnance Materiel and Related Materials Including Chemicals TM 9-247

Metal Body Repair and Related Operations FM 43-2

Operator's and Organizational Maintenance Manual for Radio Sets TM 11-5820-498-12

Operator's and Organizational Maintenance Manual Including Repair Parts and Special Tools List Simplified Test Equipment for Internal Combustion Engines Reprogrammable (STE/ICE-R) (NSN 4910-01-222-6589) TM 9-4910-571-12&P

Operator's Manual, Radio Set, AN/VRC-46 TM 11-5820-401-10-1

Operator's Manual, Radio Set, AN/VRC-90A TM 11-5820-890-10-1

Operator's, Unit, Direct Support, and General Support Maintenance Manual for Lead-Acid Storage Batteries TM 9-6140-200-14

Ordnance Tracked and Wheeled Vehicle Hull and Chassis Wiring, Repair of	TB ORD 650
Organizational Care, Maintenance, and Repair of Pneumatic Tires and Inner Tubes	TM 9-2610-200-14
Painting Instructions for Field Use	TM 43-0139
Purging, Cleaning, and Coating Interior Ferrous and Terne Sheet Vehicle Fuel Tanks	TB 43-0212
Repair of Tents, Canvas, and Webbing	FM 10-16
Rigging Techniques, Procedures, and Applications	FM 5-125
Use and Care of Hand Tools and Measuring Tools	TM 9-243
Use of Antifreeze Solutions and Cleaning Compounds in Engine Cooling Systems	TB 750-651
Welding Theory and Application	TM 9-237

e. Cold Weather Operation.

Basic Cold Weather Manual	FM 31-70
Northern Operations	FM 31-71
Operation and Maintenance of Ordnance Materiel in Cold Weather (0° to -65°F)	FM 9-207

f. Decontamination.

Decontamination Operations Facilities & Equipment	TB 700-4
NBC Decontamination	FM 3-5
NBC Protection	FM 3-4

g. Maintenance of Special Purpose Kits.

Operator and Organizational Maintenance Manual for Chemical Alarm	TM 3-6665-225-12
Operator's and Unit Maintenance Manual Including Repair Parts and Special Tools List for Decontaminating Apparatus: M13	TM 3-4230-214-12&P
Operator, Organizational, Direct Support, and General Support Maintenance Manual Including Repair Parts and Special Tools List for Various Machine Gun Mounts	TM 9-1005-245-14

h. General.

Operator's Manual (M998 Series)	TM 9-2320-280-10
Operator's Manual (M1008 Series)	TM 9-2320-289-10
Operator's Manual (M35 Series)	TM 9-2320-361-10
Operator's Manual (M939 Series)	TM 9-2320-272-10
Principles of Automotive Vehicles	TM 9-8000
Procedures for Destruction of Tank-Automotive Equipment to Prevent Enemy Use (US Army Tank-automotive and Armaments Command)	TM 750-244-6
Route Reconnaissance and Classification	FM 5-36
Soldier's Manual MOS 88M Motor Transport Operator, Skill Levels 1/2	STP 55-88-M12-SM

i. Land, Sea, and Air Shipment.

Airdrop of Supplies and Equipment: Rigging 5-Ton Trucks	FM 10-526
Containerization of Military Vehicles	MTMCTEA Ref 95-55-23
Lifting and Tiedown of U.S. Military Helicopters	MTMCTEA Ref 95-55-21
Marine Lifting and Lashing Handbook	MTMCTEA Ref 95-55-22
Marine Terminal Lifting Guidance	MTMCTEA Pam 56-1

A-4. OTHER PUBLICATIONS (CONT)

i. Land, Sea, and Air Shipment (Cont).

Multiservice Helicopter External Air Transport: Basic Operations and Equipment FM 55-450-3
Multiservice Helicopter External Air Transport: Dual-Point Load Rigging Procedures FM 55-450-5
Multiservice Helicopter External Air Transport: Single-Point Load Rigging Procedures FM 55-450-4
Standard Characteristics (Dimensions, Weight, and Cube) for Transportability of Military
Vehicles and Other Outsize/Overweight Equipment (in TOE Line Sequence) TB 55-46-1
Tiedown Handbook for Rail Movements MTMCTEA Pam 55-19
Tiedown Handbook for Truck Movements MTMCTEA Ref 92-55-20

APPENDIX B

MAINTENANCE ALLOCATION CHART (MAC)

SECTION I

INTRODUCTION

B-1. The Army Maintenance System MAC.

a. This introduction (Section I) provides a general explanation of all maintenance and repair functions authorized at various maintenance levels under the standard Army Maintenance System concept.

b. The Maintenance Allocation Chart (MAC) in Section II designates overall authority and responsibility for the performance of maintenance functions on the identified end item or component. The application of the maintenance functions to the end item or component will be consistent with the capacities and capabilities of the designated maintenance levels, which are shown on the MAC in column (4) as:

Unit - includes two subcolumns, C (Operator/Crew) and O (Unit) maintenance.

Direct Support - includes an F subcolumn.

General Support - includes an H subcolumn.

Depot - includes a D subcolumn.

c. Section III lists the tools and test equipment (both special tools and common tool sets) required for each maintenance function as referenced from Section II.

d. Section IV contains supplemental instructions and explanatory notes for a particular maintenance function.

B-2. Maintenance Functions. Maintenance functions are limited to and defined as follows:

a. **Inspect.** To determine the serviceability of an item by comparing its physical, mechanical, and/or electrical characteristics with established standards through examination (e.g. by sight, sound, or feel).

b. **Test.** To verify serviceability by measuring the mechanical, pneumatic, hydraulic, or electrical characteristics of an item and comparing those characteristics with prescribed standards.

c. **Service.** Operations required periodically to keep an item in proper operating condition; e.g. to clean (includes decontaminate, when required), to preserve, to drain, to paint, or to replenish fuel, lubricants, chemicals fluids, or gases.

d. **Adjust.** To maintain or regulate, within prescribed limits, by bringing into proper position, or by setting the operating characteristics to specified parameters.

e. **Align.** To adjust specified variable elements of an item to bring about optimum or desired performance.

f. **Calibrate.** To determine and cause corrections to be made or to be adjusted on instruments or Test, Measurement, and Diagnostic Equipment (TMDE) used in precision measurement. Consists of comparison of two instruments, one of which is a certified standard of known accuracy, to detect and adjust any discrepancy in the accuracy of the instrument being compared.

g. **Remove/Install.** To remove and install the same item when required to perform service or other maintenance functions. Install may be the act of emplacing, seating, or fixing into position a spare, repair part, or module (component or assembly) in a manner to allow the proper functioning of an equipment or system.

h. **Replace.** To remove an unserviceable item and install a serviceable counterpart in its place. "Replace " is authorized by the MAC and assigned maintenance level is shown as the 3d position code of the SMR code.

i. **Repair.** The application of maintenance services¹ including fault location/troubleshooting², removal/installation, and disassembly/assembly³ procedures, and maintenance actions⁴ to identify troubles and restore serviceability to an item by correcting specific damage, fault, malfunction, or failure in a part, subassembly, module (component or assembly), end item, or system.

j. **Overhaul.** That maintenance effort (service/action) prescribed to restore an item to a completely serviceable/operational condition as required by maintenance standards in appropriate technical publications (i.e., DMWR). Overhaul is normally the highest degree of maintenance performed by the Army. Overhaul does not normally return an item to like new condition.

k. **Rebuild.** Consists of those services/actions necessary for the restoration of unserviceable equipment to a like new condition in accordance with original manufacturing standards. Rebuild is the highest degree of material maintenance applied to Army equipment. The rebuild operation includes the act of returning to zero those age measurements (e.g., hours/miles) considered in classifying Army equipment/components.

B-3. Explanation of Columns in the MAC, Section II.

a. **Column 1, Group Number.** Column 1 lists functional group code numbers, the purpose of which is to identify maintenance significant components, assemblies, subassemblies, and modules with the next higher assembly.

b. **Column 2, Component/Assembly.** Column 2 contains the item names of components , assemblies, subassemblies, and modules for which maintenance is authorized.

c. **Column 3, Maintenance Function.** Column 3 lists the functions to be performed on the items listed in Column 2. (For detailed explanation of these functions, see Paragraph B-2.)

d. **Column 4, Maintenance Level.** Column 4 specifies each level of maintenance authorized to perform each function listed in Column 3, by indicating work time required (expressed in man-hours in whole hours or decimals) in the appropriate subcolumn. This work-time figure represents the active time required to perform that maintenance function at the indicated level of maintenance. If the number or complexity of the tasks within the listed maintenance function vary at different maintenance levels, appropriate work-time figures are to be shown for each level. The work-time figure represents the average time required to restore an item (assembly, subassembly, component, module, end item, or system) to a serviceable condition under typical field operating conditions.

¹Services - Inspect, test, service, adjust, align calibrate, and/or replace.

²Fault location/troubleshooting - The process of investigating and detecting the cause of equipment malfunction; the act of isolating a fault within a system or Unit Under Test (UUT).

³Disassembly/assembly - The step-by-step breakdown (taking apart) of a spare/functional group coded item, to the level of its least component, that is assigned an SMR code for the level of maintenance under consideration (i.e., identified as maintenance significant).

⁴Actions - Welding, grinding, riveting, straightening, facing, machining, and/or resurfacing.

This time includes preparation time (including any necessary disassembly/assembly time), troubleshooting/fault location time, and quality assurance time in addition to the time required to perform the specific tasks identified for the maintenance functions authorized in the maintenance allocation chart. The symbol designations for the various maintenance levels are as follows:

- C Operator or crew maintenance
- O Unit maintenance
- F Direct Support maintenance
- L Specialized Repair Activity (SRA)⁵
- H General Support maintenance
- D Depot maintenance

e. **Column 5, Tools and Test Equipment Reference Code.** Column 5 specifies, by code, those common tools sets (not individual tools), common TMDE, and special tools, special TMDE, and special support equipment required to perform the designated functions. Codes are keyed to tools and test equipment in Section III.

f. **Column 6, Remarks.** When applicable, this column contains a letter code, in alphabetical order, which is keyed to the remarks contained in Section IV.

B-4. Explanation of Columns in Tool and Test Equipment Requirements, Section III.

- a. **Column 1, Reference Code.** The tool and test equipment reference code correlates with a code used in the MAC, Section II column 5.
- b. **Column 2, Maintenance Level.** The lowest level of maintenance authorized to use the tool or test equipment.
- c. **Column 3, Nomenclature.** Name or identification of the tool or test equipment.
- d. **Column 4, National Stock Number.** The National Stock Number of tool or test equipment.
- e. **Column 5, Tool Number.** The manufacturer's part number, model number, or type number.

B-5. Explanation of Columns in Remarks, Section IV.

- a. **Column 1, Remarks Code.** The code recorded in column 6, Section II.
- b. **Column 2, Remarks.** This column lists information pertinent to the maintenance function being performed as indicated in the MAC, Section II.

⁵This maintenance level is not included in Section II, Column (4) of the Maintenance Allocation Chart. Functions to this level of maintenance are identified by a work-time figure in the "H" column of Section II, Column (4), and an associated reference code is used in the Remarks column (6). This code is keyed to Section IV, Remarks, and the SRA complete repair application is explained there.

Section II. MAINTENANCE ALLOCATION CHART FOR THE MTV VEHICLE

(1) Group Number	(2) Component/Assembly	(3) Maintenance Function	(4) Maintenance Level					(5) Tools and Equipment Ref Code	(6) Remarks Code
			Unit		Direct Support	General Support	Depot		
			C	O	F	H	D		
0100	ENGINE ASSEMBLY	Inspect		0.1				80	
		Test		1.5	0.3			80,81	
		Adjust			3.0			58,62,80,82	
		Service		0.8				59,61,80	
		Replace			7.0			19,58,61,63,80,81	
		Repair		0.4	1.6	3.3		19,35,36,46,58,61,62,63,80,81	
0101	CYLINDER HEAD ASSEMBLY	Inspect			0.1			80	
		Replace			2.0			46,58,61,62,80	
		Repair				2.5		58,61,62,63,64,80,83	
0102	CRANKSHAFT	Replace				16.0		58,59,62,73,80	
		Repair			3.8	16.0		19,35,36,58,61,62,63,80	
0103	FLEXPLATE, ENGINE	Replace			6.5			58,61,80	
		Repair			1.0			58,61,80	
0104	PISTON ASSEMBLY	Replace				9.0		58,59,61,62,64,80,81	
		Repair				0.6		80	
0105	CAMSHAFT ASSEMBLY	Replace				3.1		17,58,59,61,62,80	
		Repair				1.2		58,80	
0105	ROCKER ARM AND PUSH RODS	Replace			2.0			46,61,62,63,80	
		Repair			0.3			59,80	
0106	COOLER, ENGINE OIL	Replace			1.3			58,80	
		Repair			0.3			58,80	
0108	MANIFOLDS, INLET AND EXHAUST	Replace			1.5			58,62,63,80,81	
0301	INJECTOR ASSEMBLY, FUEL	Replace			2.1			46,59,80,82	
		Adjust			1.6			58,80,81,82	
0304	AIR INTAKE SYSTEM	Service		0.3					
		Repair		0.3				48,59,	

Section II. MAINTENANCE ALLOCATION CHART FOR THE MTV VEHICLE (CONT)

(1) Group Number	(2) Component/Assembly	(3) Maintenance Function	(4) Maintenance Level					(5) Tools and Equipment Ref Code	(6) Remarks Code
			Unit		Direct Support	General Support	Depot		
			C	O	F	H	D		
0304	INTAKE AIR CLEANER	Service		0.2					
		Replace		0.8				6,48,59,80	
		Repair		0.4				59,80	
0305	TURBOCHARGER	Replace			0.8			58,63,80,81	
0306	FUEL TANK	Inspect	0.1						
		Replace		1.5				59,61,80	
0308	GOVERNOR, ENGINE SPEED	Replace			1.0			59,62,78,80,81	
		Repair		0.5	0.7			59,80	
0309	FILTER, FUEL/WATER SEPARATOR	Inspect	0.2						
		Service	0.2	0.3				80	
		Replace		0.5				59,80	
0311	ETHER STARTING AID	Replace		0.6				59,61,80	
0312	ACCELERATOR/HAND THROTTLE	Replace		0.5				59,80	
		Adjust		0.2				59,80	
0401	EXHAUST MUFFLER/PIPES	Inspect	0.1	0.2					
		Replace		0.9				59,61,80	
0501	RADIATOR/CHARGE AIR COOLER	Inspect	0.1						
		Replace		2.5				2,31,55,61,80	
		Service		1.5				61,80	
0501	RADIATOR OVERFLOW TANK	Repair		0.6	2.0			2,31,55,61,80	
		Replace		0.5				48,59,80	
		Repair		0.3				80	
0502	SHROUD, FAN	Replace		1.0				59,61,80,90	
0503	HOSES, WATER	Replace		0.5				59,61,80,90	
0504	PUMP, WATER	Replace		0.8				18,59,61,80,90	
0505	CLUTCH, ENGINE FAN	Inspect		1.0				59	
		Service		0.2				61	
		Replace		1.5				2,55,59,80	
		Repair			1.2			58,61,62,63,80,81	

Section II. MAINTENANCE ALLOCATION CHART FOR THE MTV VEHICLE (CONT)

(1) Group Number	(2) Component/Assembly	(3) Maintenance Function	(4) Maintenance Level					(5) Tools and Equipment Ref Code	(6) Remarks Code
			Unit		Direct Support	General Support	Depot		
			C	O	F	H	D		
0601	ALTERNATOR, 100 AMP	Inspect		0.2					
		Test		0.5	1.5			61,65,80	
		Replace		1.0				61,80	
		Repair		0.2	0.5			40,58,59,61,65,80,81	
0603	STARTING MOTOR, ENGINE	Inspect		0.1					
		Test		0.5	0.5			59,65	
		Replace		1.5				2,8,59,61,80	
		Repair			2.1			54,58,61,62,78,80	
0606	SOLENOID, FUEL SHUTOFF	Replace			1.0			62,80,82	
0607	CABLE ASSEMBLY, DASHBOARD	Test		0.5				58	
		Replace		2.9				59,61,78,80	
		Repair		1.0	0.6			58,59,63,80	
0607	DISPLAY, LIGHTED INDICATOR	Test		0.3					
		Replace		0.5				80,90	
		Repair		0.3				80	
0608	JUNCTION BOX ASSEMBLY, M1084/M1086	Inspect	0.1						
		Replace		1.5				59,61,80,90	
		Repair		1.5				59,61,65,80	
0608	JUNCTION BOX ASSEMBLY, M1089	Inspect	0.1						
		Replace		1.5				59,61,80,90	
		Repair		1.5				59,61,65,80	
0609	LIGHT ASSEMBLY, BACKUP	Inspect	0.1						
		Replace		0.8				59,80	
		Repair		0.3				80	
0609	LIGHT, BLACKOUT DRIVE	Inspect	0.1						
		Replace		0.8				59,61,80	
		Repair		0.5				80	
0609	TAILLIGHT ASSEMBLY, COMPOSITE	Inspect	0.1						
		Replace		0.8				59,61,80	

Section II. MAINTENANCE ALLOCATION CHART FOR THE MTV VEHICLE (CONT)

(1) Group Number	(2) Component/Assembly	(3) Maintenance Function	(4) Maintenance Level					(5) Tools and Equipment Ref Code	(6) Remarks Code
			Unit		Direct Support	General Support	Depot		
			C	O	F	H	D		
0609	LIGHT ASSEMBLY, FRONT TURN SIGNAL AND PARK	Repair		0.5				80	
		Inspect	0.1						
0609	HEADLIGHT	Replace		0.8				59,61,80	
		Repair		0.5				80	
		Inspect	0.1						
		Adjust		0.4					
0609	WORKLIGHT ASSEMBLY, M1088/M1089 STATIONARY	Replace		1.0				59,61,80	
		Inspect	0.1						
		Replace		0.8				80	
0610	AUDIBLE ALARM	Repair		0.3				80	
		Inspect	0.1						
		Replace		0.6				80	
0611	HORN, CAB	Inspect	0.1						
0612	BOX ASSEMBLY, BATTERY	Replace		0.4				59,80	
		Inspect	0.1						
		Test		0.5				59,80	
		Service		0.3				59	A
0613	CABLE ASSEMBLY, LH/RH CAB AND DOOR MARKER LIGHTS	Replace		1.0				59,61,80	
		Repair		0.2				65	
		Inspect	0.1						
		Replace		0.8				80	
0613	CABLE ASSEMBLY, LOWER, CAB MARKER LIGHTS, M1093/M1094	Repair		0.7				65	
		Inspect	0.1						
		Replace		0.6				80,90	
0613	CABLE ASSEMBLY, UPPER, CAB CLEARANCE AND MARKER LIGHTS, M1093/M1094	Repair		0.5				65	
		Inspect	0.1						
		Replace		0.8				80,90	
0613	CABLE ASSEMBLY, STE/ICE-R	Repair		0.5	0.8			65	
		Replace		1.0				80	
		Repair		0.5				65	
		Replace		0.8				80,90	

Section II. MAINTENANCE ALLOCATION CHART FOR THE MTV VEHICLE (CONT)

(1) Group Number	(2) Component/Assembly	(3) Maintenance Function	(4) Maintenance Level					(5) Tools and Equipment Ref Code	(6) Remarks Code
			Unit		Direct Support	General Support	Depot		
			C	O	F	H	D		
0613	CABLE ASSEMBLY, CAB CLEARANCE AND MARKER LIGHTS	Inspect	0.1						
		Replace		1.2				59,80	
		Repair		0.5	0.8			65	
0613	CABLE ASSEMBLY, WARNING LIGHT	Replace		0.5				50,80,90	
		Repair		0.3	0.5			65	
0613	CABLE ASSEMBLY, WINDSHIELD WASHER PUMP/EMI	Replace		0.5				80	
		Repair		0.3				65	
0613	CABLE ASSEMBLY, ARCTIC KIT W/PTO	Replace		1.8				59,61,80	
		Repair		0.5	0.5			65	
0613	CABLE ASSEMBLY, CRANE POWER	Inspect	0.1						
		Replace		1.2				80	
		Repair		0.5	0.5			65	
0613	BOX ASSEMBLY, CRANE REMOTE CONTROL	Test		0.5					
		Repair		0.7				80,90	
0613	CABLE ASSEMBLY, ENGINE CONTROL	Inspect	0.1						
		Replace		2.3				59,80	
		Repair		0.5	0.5			65	
0613	CABLE ASSEMBLY, FRONT INTERVEHICULAR, 12 VDC	Replace		0.8				61,80	
		Repair		0.2	1.3			65	
0613	CABLE ASSEMBLY, FRONT LIGHTS	Replace		2.0				59,61,80,90	
		Repair		0.5	0.5			65	
0613	CABLE ASSEMBLY, REAR LIGHTS	Replace		2.8				59,61,80	
		Repair		0.5	0.5			65	
0613	CABLE, M1084/M1086 BOOM DOWN LOCKOUT SOLENOID	Replace		2.0				59,80	
		Repair		0.5	0.8			65	
0613	CABLE, M1084/M1086 BOOM DOWN SOLENOID	Replace		2.0				59,80	
		Repair		0.5	0.8			65	

Section II. MAINTENANCE ALLOCATION CHART FOR THE MTV VEHICLE (CONT)

(1) Group Number	(2) Component/Assembly	(3) Maintenance Function	(4) Maintenance Level					(5) Tools and Equipment Ref Code	(6) Remarks Code
			Unit		Direct Support	General Support	Depot		
			C	O	F	H	D		
0613	CABLE, M1084/M1086 BOOM UP LOCKOUT SOLENOID	Replace		2.0				59,80	
		Repair		0.5	0.8			65	
0613	CABLE, M1084/M1086 BOOM UP SOLENOID	Replace		2.0				59,80	
		Repair		0.5	0.8			65	
0613	CABLE, M1084/M1086 CONTROL LOCKOUT SOLENOID	Replace		2.0				59,80	
		Repair		0.5	0.8			65	
0613	CABLE, M1084/M1086 CRANE POWER	Replace		2.0				59,80	
		Repair		0.5	0.8			65	
0613	CABLE, M1084/M1086 HOIST DOWN SOLENOID	Replace		2.0				59,80	
		Repair		0.5	0.8			65	
0613	CABLE, M1084/M1086 HOIST UP LOCKOUT SOLENOID	Replace		2.0				59,80	
		Repair		0.5	0.8			65	
0613	CABLE, M1084/M1086 HOIST UP SOLENOID	Replace		2.0				59,80	
		Repair		0.5	0.8			65	
0613	CABLE, M1084/M1086 LEFT JACK CYLINDER PROXIMITY SENSOR	Replace		1.0				59,80	
		Repair		0.5	0.8			65	
0613	CABLE, M1084/M1086 OVERLOAD LOCKOUT	Replace		2.0				59,80	
		Repair		0.5	0.8			65	
0613	CABLE, M1084/M1086 REMOTE CONTROL	Replace		2.0				59,80	
		Repair		0.5	0.8			65	
0613	CABLE, M1084/M1086 SWING CCW SOLENOID	Replace		2.0				59,80	
		Repair		0.5	0.8			65	
0613	CABLE, M1084/M1086 SWING CW SOLENOID	Replace		2.0				59,80	
		Repair		0.5	0.8			65	
0613	CABLE, M1084/M1086 SYSTEM SHUTDOWN SOLENOID	Replace		2.0				59,80	
		Repair		0.5	0.8			65	

Section II. MAINTENANCE ALLOCATION CHART FOR THE MTV VEHICLE (CONT)

(1) Group Number	(2) Component/Assembly	(3) Maintenance Function	(4) Maintenance Level					(5) Tools and Equipment Ref Code	(6) Remarks Code
			Unit		Direct Support	General Support	Depot		
			C	O	F	H	D		
0613	CABLE, M1084/M1086 TELESCOPE IN SOLENOID	Replace		2.0				59,80	
		Repair		0.5	0.8			65	
0613	CABLE, M1084/M1086 TELESCOPE OUT LOCKOUT SOLENOID	Replace		2.0				59,80	
		Repair		0.5	0.8			65	
0613	CABLE, M1084/M1086 TELESCOPE OUT SOLENOID	Replace		2.0				59,80	
		Repair		0.5	0.8			65	
0613	CABLE, M1089 BOOM DOWN LOCKOUT SOLENOID	Replace		2.0				59,80	
		Repair		0.5	0.8			65	
0613	CABLE, M1089 BOOM DOWN SOLENOID	Replace		2.0				59,80	
		Repair		0.5	0.8			65	
0613	CABLE, M1089 BOOM UP LOCKOUT SOLENOID	Replace		2.0				59,80	
		Repair		0.5	0.8			65	
0613	CABLE, M1089 BOOM UP SOLENOID	Replace		2.0				59,80	
		Repair		0.5	0.8			65	
0613	CABLE ASSEMBLY, M1089 CONTROL PANEL POWER	Replace		2.0				80	
		Repair		0.5	0.8			65	
0613	CABLE, M1089 CRANE POWER	Replace		2.0				59,80	
		Repair		0.5	0.8			65	
0613	CABLE, M1089 HOIST DOWN SOLENOID	Replace		2.0				59,80	
		Repair		0.5	0.8			65	
0613	CABLE, M1089 HOIST UP LOCKOUT SOLENOID	Replace		2.0				59,80	
		Repair		0.5	0.8			65	
0613	CABLE, M1089 HOIST UP SOLENOID	Replace		2.0				59,80	
		Repair		0.5	0.8			65	
0613	CABLE, M1089 HYDRAULIC SYSTEM SOLENOID	Replace		2.0				59,80	
		Repair		0.5	0.8			65	
0613	CABLE, M1089 LEFT SIDE REMOTE CONTROL	Replace		2.0				59,80	
		Repair		0.5	0.8			65	

Section II. MAINTENANCE ALLOCATION CHART FOR THE MTV VEHICLE (CONT)

(1) Group Number	(2) Component/Assembly	(3) Maintenance Function	(4) Maintenance Level				(5) Tools and Equipment Ref Code	(6) Remarks Code	
			Unit		Direct Support	General Support			Depot
			C	O	F	H			D
0613	CABLE, M1089 OVERLOAD LOCKOUT	Replace		2.0			59,80		
		Repair		0.5	0.8		65		
0613	WIRING HARNESS, M1089 REMOTE CONTROL	Replace		2.0			80		
		Repair		0.5	0.8		65		
0613	CABLE, M1089 RIGHT SIDE REMOTE CONTROL	Replace		2.0			59,80		
		Repair		0.5	0.8		65		
0613	CABLE, M1089 SWING CCW SOLENOID	Replace		2.0			59,80		
		Repair		0.5	0.8		65		
0613	CABLE, M1089 SWING CW SOLENOID	Replace		2.0			59,80		
		Repair		0.5	0.8		65		
0613	CABLE, M1089 TELESCOPE IN SOLENOID	Replace		2.0			59,80		
		Repair		0.5	0.8		65		
0613	CABLE, M1089 TELESCOPE OUT LOCKOUT SOLENOID	Replace		2.0			59,80		
		Repair		0.5	0.8		65		
0613	CABLE, M1089 TELESCOPE OUT SOLENOID	Replace		2.0			59,80		
		Repair		0.5	0.8		65		
0613	BOX ASSEMBLY, WRECKER REMOTE CONTROL	Repair		1.6			59,80		
		Repair		0.5	0.8		65		
0613	CABLE ASSEMBLY, M1090/M1094 DUMP	Replace		0.8			59,61,80		
		Repair		0.5	0.8		65		
0613	CABLE ASSEMBLY, M1090/M1094 DUMP POWER	Replace		1.2			59,61,80		
		Repair		0.5	0.8		65		
0613	CABLE ASSEMBLY, PTO	Replace		1.6			59,61,80		
		Repair		0.5	0.8		65		
0613	CABLE ASSEMBLY, REAR INTERVEHICULAR, 24 VDC	Replace		0.6			61,80		
		Repair		0.5	0.8		65		
0613	CABLE ASSEMBLY, START AND CHARGING	Replace		2.0			59,80		
		Repair		0.5	0.8		65		

Section II. MAINTENANCE ALLOCATION CHART FOR THE MTV VEHICLE (CONT)

(1) Group Number	(2) Component/Assembly	(3) Maintenance Function	(4) Maintenance Level					(5) Tools and Equipment Ref Code	(6) Remarks Code
			Unit		Direct Support	General Support	Depot		
			C	O	F	H	D		
0613	CABLE ASSEMBLY, WINCH CONTROL VALVE	Replace		1.8				59,61,80	
		Repair		0.5	0.8			65	
0613	CABLE ASSEMBLY, TRANSMISSION AUXILIARY OIL COOLER FAN	Replace		1.8				59,61,80	
		Repair		0.5				65	
0705	VEHICLE INTERFACE MODULE	Replace		0.6				80	
		Repair		0.8				80	
0708	TORQUE CONVERTER	Adjust			0.9			22,61,62,80	
		Remove/Install			0.8			48,61,62,64,80	
		Repair			1.3			34,58,61,62,64,80	
0710	TRANSMISSION	Inspect		0.4				80	
		Service		1.5				59,61,80	
		Replace			7.0			58,61,62,63,80,81,87	
		Repair		0.4	2.7	1.9		3,22,23,28,29,31,43,58,59,61,62,63,80,81,87	
0710	MODULE, FRONT SUPPORT	Remove/Install					2.0	58,59,61,62,63,80	
		Repair					0.7	34,58,59,61,62,63,80	
0710	MODULE, PLANETARY GEAR (P1)	Remove/Install					2.0	61,62,73,80	
		Repair					1.5	61,62,73,80	
0710	MODULE, PLANETARY (P2)	Remove/Install					2.0	3,58,61,62,63,80	
		Repair					1.9	3,23,58,61,62,63,73,80	
0710	PLANETARY CARRIER (P3)	Remove/Install					2.0	3,58,62,80	
		Repair					1.9	3,31,58,62,80	
0710	MODULE, MAIN SHAFT	Remove/Install					2.0	61,62,80	
		Repair					0.4	61,62,80	

Section II. MAINTENANCE ALLOCATION CHART FOR THE MTV VEHICLE (CONT)

(1) Group Number	(2) Component/Assembly	(3) Maintenance Function	(4) Maintenance Level					(5) Tools and Equipment Ref Code	(6) Remarks Code
			Unit		Direct Support	General Support	Depot		
			C	O	F	H	D		
0710	MODULE, CONVERTER HOUSING	Remove/ Install Repair				4.3		3,58,59,61,62,80 3,23,29,58,59,61,62,80	
0713	CLUTCH ASSEMBLY, C3/C4/C5, TRANSMISSION	Remove/ Install Repair				2.0		58,59,61,62,80 43,58,59,61,62,80	
0713	MODULE, ROTATING CLUTCH	Remove/ Install Repair				2.0		3,58,61,62,80 3,23,28,58,61,62,80	
0714	VALVE ASSEMBLY, CONTROL MODULE	Remove/ Install Repair				2.0		58,61,62,63,80,81 61,63,80,81	
0714	BODY ASSEMBLY, MAIN VALVE	Service Remove/ Install Repair		1.5				59,61,80 58,61,62,63,80,81 58,61,62,63,80,81	
0801	MODULE, TRANSFER CASE	Adjust Remove/ Install Repair					1.0 2.0	25,58,59,61,62,63,73,76,80,81 27,31,37,52,58,59,62,80	
0802	HOUSING ASSEMBLY, C6 AND C7 CLUTCH	Remove/ Install Repair					2.0 0.8	58,61,62,63,80 23,27,30,31,32,33,58,61,62,63,64,73,80	
0802	CONTROL VALVE ASSEMBLY	Remove/ Install Repair					2.0 1.0	58,61,63,80,81 58,61,63,80,81	
0804	PUMP ASSEMBLY, OIL	Replace Repair					1.0 0.8	81 81	
0900	PROPELLER SHAFT	Inspect		0.1					

Section II. MAINTENANCE ALLOCATION CHART FOR THE MTV VEHICLE (CONT)

(1) Group Number	(2) Component/Assembly	(3) Maintenance Function	(4) Maintenance Level					(5) Tools and Equipment Ref Code	(6) Remarks Code
			Unit		Direct Support	General Support	Depot		
			C	O	F	H	D		
1000	AXLE ASSEMBLY, FRONT	Service		0.5				61	
		Repair		0.6				59,61,80	
		Replace		0.5				59,61,80	
		Inspect	0.1	0.3	0.7			80	
		Adjust			1.0			59,81	
		Service		0.5				61,80	
		Replace				4.5		58,59,61,6 2,63,72,80	
1002	CARRIER ASSEMBLY, DIFFERENTIAL	Repair		2.3	2.2	6.0		58,59,61,6 2,63,80	
		Inspect		0.1	0.1	0.1		80,81	
		Service			0.3			80	
		Replace				4.6		25,58,59,6 1,62,80,81	
1004	STEERING KNUCKLE, AXLE	Repair				2.7		58,59,61,6 2,80,81	
		Inspect			0.2				
		Adjust			2.5			81	
1100	AXLE ASSEMBLY, INTERMEDIATE	Service			0.3			81	
		Replace			5.1			58,59,61,6 2,73,80	
		Inspect	0.1	0.4	0.7				
		Service		0.8				59,61,80	
1100	AXLE ASSEMBLY, REAR	Replace			4.5			58,59,61,6 2,63,80,87	
		Repair			1.6	6.0		25,58,59,6 1,62,69,80	
		Inspect	0.1	0.4	0.7				
1102	CARRIER ASSEMBLY, DIFFERENTIAL, INTERMEDIATE AXLE	Service		0.8				59,61,80	
		Replace			4.5			38,58,59,6 1,62,80,87	
		Repair			0.9	6.0		25,58,59,6 1,62,80,87, 88	
		Inspect		0.1	0.1	1.0		80,81	
		Service			0.3		80		

Section II. MAINTENANCE ALLOCATION CHART FOR THE MTV VEHICLE (CONT)

(1) Group Number	(2) Component/Assembly	(3) Maintenance Function	(4) Maintenance Level					(5) Tools and Equipment Ref Code	(6) Remarks Code
			Unit		Direct Support	General Support	Depot		
			C	O	F	H	D		
1102	CARRIER ASSEMBLY, DIFFERENTIAL, REAR AXLE	Replace				4.6		25,58,59,6 1,62,69,80	
		Repair				2.7		25,58,59,6 1,62,63,69, 75,80	
		Inspect		0.1	0.1	1.0		80,81	
		Service			0.3			80	
		Replace				4.6		25,58,59,6 1,62,80,81, 88	
1202	BRAKE ASSEMBLY, FRONT AXLE	Repair				2.7		25,39,58,5 9,61,62,73, 75,80	
		Inspect		0.1	1.0			61,80,81	
		Adjust		0.4				59,61,80	
1202	BRAKE ASSEMBLY, INTERMEDIATE AND REAR AXLE	Repair		1.5	0.5			59,61,80,8 5	
		Inspect		0.1	1.0			61,80,81	
		Adjust		0.4				59,61,80	
1208	AIR DRYER, BRAKE SYSTEM	Repair		1.5	0.5			59,61,80,8 5	
		Replace		0.5				59,61,80	
1209	AIR COMPRESSOR	Repair		1.0				59,61,80	
		Adjust		0.6				61,80	
1311	WHEEL ASSEMBLY, PNEUMATIC TIRE	Replace			1.2			58,62,63,8 0,81	
		Inspect	0.1					59	B
1313	TIRE, PNEUMATIC	Replace	1.0	1.2				59,61	
		Repair		2.0				59,61	
1401	STEERING SYSTEM	Replace		2.0				59,61	
		Inspect		0.2					
		Adjust			1.0			58,62,80	
1407	STEERING GEAR ASSEMBLY	Repair		1.0	1.5			56,58,59,6 1,62,63,80, 81	
		Replace			4.0			58,62,80	
1410	PUMP, POWER STEERING	Replace			1.5			49,58,61,6 2,80	

Section II. MAINTENANCE ALLOCATION CHART FOR THE MTV VEHICLE (CONT)

(1) Group Number	(2) Component/Assembly	(3) Maintenance Function	(4) Maintenance Level					(5) Tools and Equipment Ref Code	(6) Remarks Code
			Unit		Direct Support	General Support	Depot		
			C	O	F	H	D		
1411	HOSES, POWER STEERING	Replace		0.3				59,61,80,90	
1413	HYDRAULIC RESERVOIR, POWER STEERING	Service	0.1	0.5				80	
		Replace		0.8				61,80,90	
1501	FRAME ASSEMBLY	Inspect	0.1	0.3					
		Repair		0.8	14.0			58,59,61,62,63,80,81	
1501	BOOM REST ASSEMBLY, CRANE	Inspect	0.1						
		Replace			2.0			58,59,61,62,80,81,87	
		Repair			0.7			58,59,61,62,80,81,87	
1504	RETAINER, SPARE TIRE	Inspect	0.1	0.1					
		Replace		3.0				59,61,80	
		Repair		0.6				59,61,80	
1506	FIFTH WHEEL ASSEMBLY	Inspect	0.1						
		Service		0.5				21,80	
		Replace			4.0			58,61,62,80,81	
		Repair			2.5			21,58,61,62,66,80,81	
1601	LEAF SPRING ASSEMBLIES	Inspect	0.1	0.2					
		Service		0.3				59	
		Replace			2.7			58,59,61,62,80,81	
1604	SHOCK ABSORBERS	Inspect	0.1	0.3					
		Replace		0.5				59,61,80	
1605	STABILIZER BAR, REAR	Inspect		0.2					
		Replace		2.0				59,61,70,80	
		Repair		1.5				59,80	
1801	CAB BODY, STANDARD	Inspect	0.1						
		Replace			60.0			58,59,62,63,80,81	
		Repair		0.6				59,61,80	
1801	CAB BODY, AIR DROP	Inspect	0.1						
		Replace			60.0			58,59,62,63,80,81	

Section II. MAINTENANCE ALLOCATION CHART FOR THE MTV VEHICLE (CONT)

(1) Group Number	(2) Component/Assembly	(3) Maintenance Function	(4) Maintenance Level					(5) Tools and Equipment Ref Code	(6) Remarks Code
			Unit		Direct Support	General Support	Depot		
			C	O	F	H	D		
1801	CAB DOORS, STANDARD	Repair		0.6				59,61,80	
		Inspect	0.1						
		Replace			1.0			57,61,80	
1801	CAB DOORS, AIR DROP	Repair		2.7				51,59,80	
		Inspect	0.1						
		Replace			1.0			57,61,80	
1801	SUPPORT ASSEMBLY, CAB FRONT	Repair		2.7				51,59,80	
		Inspect	0.1						
		Replace			3.0			59,61,80 7,15,59, 61,62,80, 81	
1801	SUPPORT ASSEMBLY, CAB REAR	Inspect	0.1						
		Replace		1.1				59,61,80	
		Repair						59,80	
1802	WINDSHIELD	Replace		1.0				59,61,80	
		Inspect	0.1						
		Repair		0.8				59,80	
1802	FENDER, VEHICULAR, FRONT	Replace			0.6			57,61,80	
		Inspect	0.1						
		Repair		2.0				59,61,80	
1803	ROOF, CAB, M1093/M1094	Replace		0.5				59,80	
		Inspect	0.1						
		Repair		1.0				47,52,59,6 1,80	
1805	STEP ASSEMBLY, CAB	Replace		1.0				59,80	
		Inspect	0.1						
		Repair		0.7				59,80	
1808	TOOL BOX ASSEMBLY	Inspect	0.1						
		Replace		0.5				49,59,61,8 0	
		Repair		0.5				59,61,80	
1808	STOWAGE BOX, CAB	Replace		0.8				59,80	
		Inspect	0.1						
		Repair		0.5				59,80	
1810	BODY, CARGO, (W/MHC, LWB AND LWB W/MHC)	Inspect	0.1						
		Replace			4.0			58,59,61,6 2,80	
		Repair		0.5				59,61,80	
1810	DUMP BODY ASSEMBLY	Inspect	0.1						
		Replace			4.0			58,61,62,8 0	
		Repair		0.5	4.0			58,59,61,6 2,80	

Section II. MAINTENANCE ALLOCATION CHART FOR THE MTV VEHICLE (CONT)

(1) Group Number	(2) Component/Assembly	(3) Maintenance Function	(4) Maintenance Level					(5) Tools and Equipment Ref Code	(6) Remarks Code
			Unit		Direct Support	General Support	Depot		
			C	O	F	H	D		
1810	DUMP HYDRAULIC CYLINDER	Inspect	0.1						
		Replace Repair			1.0		2.5	59,62,80 59,61,62,80,89	
1810	DUMP TAILGATE ASSEMBLY	Inspect	0.1						
		Replace Repair		1.5 0.8				80 80	
1812	BOX ASSEMBLY, TOOL, M1089	Inspect	0.1						
		Remove/ Install		1.0				59,61,80	
		Repair		0.8				59,61,80	
2001	UNDERLIFT ASSEMBLY, M1089	Inspect	0.1						
		Test		0.5	0.1				
		Service		0.5				61	
		Replace			6.0			58,59,61,62,80,87	
		Repair			1.0			54,58,59,61,62,80,81,86,87	
2001	CROSSBAR ASSEMBLY, M1089	Inspect			0.1				
		Replace			0.5			58,59,61,62,80,81,86	
		Repair			1.0			58,59,61,62,81,86	
2001	LOWER ARM, UNDERLIFT	Inspect			0.1				
		Replace			2.0			58,59,61,62,80,87	
		Repair			0.5			58,59,61,62,80,87	
2001	CYLINDER, TELESCOPIC LIFT	Replace			1.5			59,61,80	
		Repair					1.0	61,62,63,80	
2001	STIFFLEG ASSEMBLY	Inspect			0.1				
		Replace			2.0			59,61,62,80,87	
		Repair			1.6	1.0		58,59,61,62,63,68,80,87	

Section II. MAINTENANCE ALLOCATION CHART FOR THE MTV VEHICLE (CONT)

(1) Group Number	(2) Component/Assembly	(3) Maintenance Function	(4) Maintenance Level					(5) Tools and Equipment Ref Code	(6) Remarks Code
			Unit		Direct Support	General Support	Depot		
			C	O	F	H	D		
2001	BOOM FRAME, FOLDING, UNDERLIFT	Inspect			0.1				
		Repair			2.5			61,80	
2001	ARM ASSEMBLY, UPPER, UNDERLIFT	Repair			2.5			58,59,61,62,80	
2001	CYLINDER, UNDERLIFT FOLD	Replace			0.5			59,61,80,87	
		Repair				0.5		59,61,62,63,80	
2001	CYLINDER, UNDERLIFT STINGER	Replace			0.5			59,61,62,80,87	
		Repair				0.5		58,61,62,63,68,80,81	
2001	WINCH, 15K SELF-RECOVERY	Inspect	0.1	4.0					
		Service		0.2				61	
		Replace			1.0			61,62,80	
		Repair			0.9			61,62,80	
2001	MOTOR, HYDRAULIC, SELF-RECOVERY WINCH	Replace			0.5			59,80	
2001	MATERIAL HANDLING CRANE (MHC), M1089	Inspect	0.1	0.5				80	
		Test	0.2		0.3			59	
		Service		0.5				61	
		Replace			6.0			59,61,62,80,87	
		Repair		0.5				9,58,59,61,62,80	
2001	CYLINDER, LIFT, M1089 MHC	Inspect	0.1						
		Test			0.2			61	
		Replace			4.0			58,62,80	
		Repair				2.0		59,61,62,63,80	
2001	CYLINDER, ERECTION, M1089 MHC	Inspect	0.1						
		Test			0.2			61	
		Replace			4.0			58,62,80	
		Repair				2.0		59,61,62,63,80,81	
2001	HOIST ASSEMBLY, M1089 MHC	Inspect	0.1						
		Test			0.2			61	

Section II. MAINTENANCE ALLOCATION CHART FOR THE MTV VEHICLE (CONT)

(1) Group Number	(2) Component/Assembly	(3) Maintenance Function	(4) Maintenance Level					(5) Tools and Equipment Ref Code	(6) Remarks Code
			Unit		Direct Support	General Support	Depot		
			C	O	F	H	D		
2001	HYDRAULIC MOTOR, HOIST, M1089 MHC	Replace			6.0			61,62,80	
		Repair			3.0			59,61,62,80	
		Inspect	0.1						
		Test			0.1			59,65	
		Replace			2.0			59,80	
2001	GEAR SET, M1089 MHC	Repair				4.2		58,59,61,62,63,80	
		Inspect		0.2					
		Test			0.2			61	
2001	BOOM ASSEMBLY, M1089 MHC	Repair			1.7			61,62,80	
		Inspect	0.1						
		Test			0.2				
2001	CYLINDER, TELESCOPIC, BOOM, M1089 MHC	Replace			8.0			58,62,80	
		Repair			2.0			58,61,62,80	
		Inspect	0.1						
		Test			0.2			61	
2001	SWING DRIVE ASSEMBLY, M1089 MHC	Replace			6.0			58,61,62,80	
		Repair				2.0		59,61,62,80	
		Inspect	0.1	0.5					
2001	MOTOR, ORBIT, HYDRAULIC, M1089 MHC	Test			0.2			61	
		Service		0.3					
		Replace			4.0			59,61,62,80	
		Repair			4.0			59,61,62,80	
2001	CYLINDER ASSEMBLY, EXTENSION, OUTRIGGER, M1089 MHC	Inspect	0.1						
		Test			0.2				
		Replace			1.0			59,61,62,80	
		Repair				3.0		59,61,62,63,80,81	
2001	CYLINDER ASSEMBLY, EXTENSION, OUTRIGGER, M1089 MHC	Inspect	0.1						
		Test			0.2			61	

Section II. MAINTENANCE ALLOCATION CHART FOR THE MTV VEHICLE (CONT)

(1) Group Number	(2) Component/Assembly	(3) Maintenance Function	(4) Maintenance Level					(5) Tools and Equipment Ref Code	(6) Remarks Code
			Unit		Direct Support	General Support	Depot		
			C	O	F	H	D		
2001	CYLINDER ASSEMBLY, JACK, M1089 MHC	Replace			3.0			80	
		Repair				5.0		61,62,80	
		Inspect	0.1						
		Test			0.2			61	
		Replace			3.0			62,80	
2001	VALVE ASSEMBLY, EIGHT-BANK, M1089 MHC	Repair				5.0		59,61,62,80	
		Inspect	0.1						
		Replace			0.5			58,59,61,80	
2001	WINCH ASSEMBLY, M1089 (30K)	Repair			2.0			58,59,61,80	
		Inspect	0.1						
		Test		0.5	0.2			63	
2001	MOTOR ASSEMBLY, DRIVE, (30K) WINCH	Replace			9.0			20,59,61,62,80,81	
		Repair			0.5			59,61,62,63,73,80,81	
		Replace			0.5			59,61,62,63,73,80,81	
2001	VALVE ASSEMBLY, MAIN, UPPER, M1089	Repair			8.0			59,61,62,63,73,80,81	
		Replace			0.5			61,62,80	
2001	VALVE ASSEMBLY, MAIN, LOWER, M1089	Repair			0.5			61,62,80	
		Replace			0.5			61,62,80	
2001	VALVE ASSEMBLY, MONO, M1089	Repair			0.5			61,62,80	
		Replace			1.5			59,61,62,80,87	
2001	MATERIAL HANDLING CRANE (MHC), M1084/M1086	Repair			1.0			59,61,62,80,87	
		Inspect	0.1						
		Test			0.2			81	
		Service		2.0				61	
		Replace			4.0			58,59,61,62,80	

Section II. MAINTENANCE ALLOCATION CHART FOR THE MTV VEHICLE (CONT)

(1) Group Number	(2) Component/Assembly	(3) Maintenance Function	(4) Maintenance Level					(5) Tools and Equipment Ref Code	(6) Remarks Code
			Unit		Direct Support	General Support	Depot		
			C	O	F	H	D		
2001	CYLINDER, LIFT, M1084/M1086 MHC	Repair				0.5		58,59,61,6 2,63,73,80, 81	
		Inspect	0.1						
		Test			2.0				65,81
		Replace			2.0				58,59,62,8 0
2001	CYLINDER, ERECTION, M1084/M1086 MHC	Repair				4.0		58,59,62,8 0	
		Inspect	0.1						
		Test			0.2				65,81
		Replace			4.0				58,62,80
2001	HOIST ASSEMBLY, M1084/M1086 MHC	Repair				4.0		59,61,63,8 0,81	
		Inspect	0.1						
		Test			0.2				65,81
		Replace			6.0				61,62,80
2001	MOTOR, HYDRAULIC, HOIST, M1084/M1086 MHC	Repair				3.5		59,61,62,8 0	
		Inspect	0.1						
		Test			0.2				65,81
		Replace			6.0				61,62,80
2001	GEAR SET, M1084/M1086 MHC	Repair				4.2		58,59,61,6 2,63,80	
		Inspect	0.1						
		Test			0.1				65,81
		Replace			2.0				59,80
2001	CYLINDER, TELESCOPIC, BOOM, M1084/M1086 MHC	Repair				4.5		61,62,80	
		Inspect	0.1						
		Test			0.1				65,81
		Replace			2.0				58,61,62,8 0
2001	SWING DRIVE ASSEMBLY, M1084/M1086 MHC	Repair				4.0		59,61,62,8 0	
		Inspect	0.1	0.5					61
		Test			0.1				65,81
		Service		0.3					

Section II. MAINTENANCE ALLOCATION CHART FOR THE MTV VEHICLE (CONT)

(1) Group Number	(2) Component/Assembly	(3) Maintenance Function	(4) Maintenance Level					(5) Tools and Equipment Ref Code	(6) Remarks Code
			Unit		Direct Support	General Support	Depot		
			C	O	F	H	D		
2001	MOTOR, ORBIT, HYDRAULIC, M1084/M1086 MHC	Replace			4.0			59,61,62,80	
		Repair			3.5	4.2		59,61,62,80	
		Inspect	0.1					61	
		Test			0.1			65,81	
		Replace			2.0			59,61,80	
2001	VALVE ASSEMBLY, CONTROL, FOUR WAY, M1084/M1086 MHC	Repair				4.2		59,61,63,73,80,81	
		Replace			0.8			59,61,62,80	
2001	VALVE ASSEMBLY, CONTROL, THREE WAY, M1084/M1086 MHC	Repair			1.1			59,61,62,80	
		Replace			0.8			59,61,62,80,81	
2001	CYLINDER, JACK, M1084/M1086 MHC	Repair			1.1			59,61,62,80,81	
		Inspect	0.1						
		Test			0.2			81	
		Replace			2.0			62,80	
2004	POWER TAKEOFF ASSEMBLY (PTO)	Repair				4.0		59,61,62,80	
		Inspect	0.1						
		Replace			1.0			58,59,61,62,80	
2201	CAB PROTECTOR, M1090/M1094	Repair			0.8			58,59,61,62,80	
		Inspect	0.1						
2202	MOTOR, WIPER, WINDSHIELD	Replace			2.0			58,80	
		Test		0.5					
2207	HEATER ASSEMBLY, PERSONNEL	Replace		1.0				80	
		Replace		2.0				59,61,80	
2210	DECALS	Repair		1.0				59,61,80	
		Inspect	0.1						
		Replace		1.0				80	

Section II. MAINTENANCE ALLOCATION CHART FOR THE MTV VEHICLE (CONT)

(1) Group Number	(2) Component/Assembly	(3) Maintenance Function	(4) Maintenance Level					(5) Tools and Equipment Ref Code	(6) Remarks Code
			Unit		Direct Support	General Support	Depot		
			C	O	F	H	D		
2401	POWER UNIT, AIR/HYDRAULIC	Inspect	0.1						
		Test		0.2					
		Service		1.0					
		Replace		3.0				59,61,80	
		Repair			2.0			59,61,62,7 1,80,81	
2402	MANIFOLD, HYDRAULIC	Inspect	0.1						
		Test		0.2					
		Replace		1.5				53,59,61,8 0	
		Repair		1.0				53,59,61,8 0	
2406	FILTER, HYDRAULIC	Service		0.3				61,80	
		Replace		0.2				61,80	
2407	LATCH, HYDRAULIC, CAB	Inspect	0.1						
		Adjust		0.5				59,61,80	
		Replace		0.5				59,61,80	
2408	RESERVOIR, HYDRAULIC	Replace		1.0				59,61,80	
		Repair		0.5				59,61,80	
2408	TANK ASSEMBLY, HYDRAULIC, M1089	Inspect	0.1						
		Service		2.0				59,61,80	
		Replace		2.0				6,9,59, 61,80	
		Repair		0.5				59,61,80	
3307	ALTERNATOR KIT, 200 AMP	Inspect	0.1	0.2					
		Test		0.5					
		Remove/Install		2.0				59,61,80	
		Replace		1.0				59,61,80	
		Repair			0.5			58,59,62,6 3,80	
3307	ALTERNATOR, 200 AMP	Inspect		0.2					
		Test		0.5	1.5			61,65,80	
		Replace		1.0				59,61,80	
		Repair		0.2	0.5			58,59,62,6 3,65,80	
3307	CRANE (LMHC), MATERIAL HANDLING, LIGHT	Inspect	0.1	0.1					
		Replace		0.5				61,78,80	
		Repair		0.5					
		Test		0.5					

Section II. MAINTENANCE ALLOCATION CHART FOR THE MTV VEHICLE (CONT)

(1) Group Number	(2) Component/Assembly	(3) Maintenance Function	(4) Maintenance Level					(5) Tools and Equipment Ref Code	(6) Remarks Code
			Unit		Direct Support	General Support	Depot		
			C	O	F	H	D		
3307	WEIGHT BLOCK AND WIRE ROPE, LMHC	Inspect	0.1						
		Replace		0.1				61,80	
		Repair		0.5				61,80	
		Test			0.5				
3307	WINCH, LMHC	Inspect	0.1						
		Replace		0.5				61,80	
		Repair		1.0				61,80	
		Test		0.5					
3307	MAST/SWING ASSEMBLY, LMHC	Inspect	0.1						
		Repair		1.0				61,80	
		Test		0.5					
3307	CONTROL BOX, LMHC	Inspect	0.1						
		Replace		0.1					
		Repair		0.5				78,80	
		Test	0.1	0.5					
3307	TROOPSEAT KIT	Remove/Install	1.0						
		Inspect	0.1						
		Replace		1.0					
		Repair		0.5				80	
3307	COVER KIT, CARGO SOFT TOP	Remove/Install	1.5						
		Inspect	0.1						
		Replace		2.0					
		Repair		0.5					
3307	WARNING LIGHT ASSEMBLY, AMBER	Inspect	0.1						
		Repair		0.4				80	
		Test		0.2					
3401	MACHINE GUN RING KIT	Inspect	0.1						
		Remove/Install			4.0			58,59,62,80,81,87	
		Repair		1.1				10,59,80	
3402	MOUNT, SMALL ARMS	Inspect	0.1						
		Replace		0.3				80	
3901	WARNING LIGHT ASSEMBLY, AMBER, M1089	Repair		0.8				59,61,80	
3903	MAST, WARNING LIGHT, AMBER, M1089	Replace		0.6				59,61,80	

Section II. MAINTENANCE ALLOCATION CHART FOR THE MTV VEHICLE (CONT)

(1) Group Number	(2) Component/Assembly	(3) Maintenance Function	(4) Maintenance Level					(5) Tools and Equipment Ref Code	(6) Remarks Code
			Unit		Direct Support	General Support	Depot		
			C	O	F	H	D		
3909	CABLE ASSEMBLY, WARNING LIGHT	Inspect	0.1						
4316	AIR HOSE, CTIS	Replace		0.5			80		
		Inspect	0.1						
4317	VALVE, INVERSION	Replace		0.4			61,80		
		Replace		0.5			61,80		
4318	CYLINDER, PNEUMATIC, TAILGATE, M1090/M1094	Replace		0.4			61,80		
4321	AIR DRYER	Inspect	0.1	0.1					
		Replace		1.0			59,61,80		
		Repair		0.6			59,61,80		
4702	GAUGE, AIR FILTER RESTRICTION	Replace		0.5			80		

Section III. TOOLS AND TEST EQUIPMENT FOR MTV VEHICLES

Tool or Test Equipment REF Code	Maintenance Level	Nomenclature	National Stock Number	Tool Number
1	O,F	ADAPTER, RADIATOR	4910-01-170-4928	J29003-A
2	O	ADAPTER, SOCKET WRENCH	5120-00-240-8702	11655788-2
2.1	O	BASE, MAGNETIC		P5646
3	H	BUSHING DRIVER SET	5120-01-391-3541	J35922
4	O	CRIMPING TOOL, TERMINAL, HAND	5120-00-165-3912	M22520/1-01
5	O	CROWFOOT ATTACHMENT, SOCKET WRENCH	5120-00-078-3809	10935497
6	O	CROWFOOT ATTACHMENT, SOCKET WRENCH	5120-00-293-1010	5120-293-1282
7	F	CROWFOOT ATTACHMENT, SOCKET WRENCH	5120-01-074-7557	FCOM19
8	O	CROWFOOT ATTACHMENT, SOCKET WRENCH	5120-01-236-9996	FCOM15
9	O	CROWFOOT ATTACHMENT, SOCKET WRENCH	5120-01-335-1089	FCO28
10	O	CROWFOOT ATTACHMENT, SOCKET WRENCH	5120-01-335-1091	FCO32
11	O	CROWFOOT ATTACHMENT, SOCKET WRENCH	5120-01-335-1119	SCO34
12	O	CROWFOOT ATTACHMENT, SOCKET WRENCH	5120-01-335-1122	SCO40
12.1	O	CROWFOOT ATTACHMENT, SOCKET WRENCH	5120-01-335-1126	SCO48

Section III. TOOLS AND TEST EQUIPMENT FOR MTV VEHICLES (CONT)

Tool or Test Equipment REF Code	Maintenance Level	Nomenclature	National Stock Number	Tool Number
13	O	CROWFOOT ATTACHMENT, SOCKET WRENCH	5120-01-335-1153	FCO20
14	O	CROWFOOT ATTACHMENT, SOCKET WRENCH	5120-01-335-1156	FCO26
15	F	CROWFOOT ATTACHMENT, SOCKET WRENCH	5120-01-348-9473	AN8508-19A
16	O	CUTTER, BOLT	5110-00-224-7057	GGG-C-740
16.1	O	DISPENSER, SEALANT	5120-00-061-1283	45RCT
17	H	DRIVER KIT, BEARING	4910-01-032-3128	8S0602
18	O	GAGE, BELT TENSION	6635-01-092-7462	0755-0101
19	O,F	GAGE, BELT TENSION	6635-01-143-2237	GA-424
20	O,F	GAGE, PRESSURE, 0-150 psi	6685-00-474-5721	111T1D05A01
21	O	GAGE, PROFILE	5220-01-357-4913	TF-0237
22	F,H	GAGE, PROFILE	5220-01-388-1460	J-38548-1
23	H	HANDLE, DRIVE	5120-00-377-2259	J8092
24	O	HEATER, GUN TYPE, ELECTRIC	4940-00-561-1002	500A
25	F,H	HOLDING BAR, PINION	5120-01-166-0573	J3453
25.1	O	INDICATOR, DIAL		P36491
26	O	INSERTER AND REMOVER, ELECTRICAL CONTACT	5120-00-915-4588	MS3447-16
27	H	INSERTER AND REMOVER, SPRING	5120-01-388-3660	J38573
28	H	INSERTER AND REMOVER, SPRING	5120-01-388-4436	J35923
29	H	INSERTER, BEARING AND BUSHING	5120-01-388-7841	J-38565
30	H	INSERTER, BEARING AND BUSHING	5120-01-389-0658	J35921-1
31	H	INSERTER, BEARING AND BUSHING	5120-01-390-1104	J 38569
32	H	INSERTER, BEARING AND BUSHING	5120-01-390-1105	J 38568-3
33	H	INSERTER, BEARING AND BUSHING	5120-01-391-5133	J 38579
34	F,H	INSERTER, BEARING AND BUSHING	5120-01-414-7398	J38566
35	F	INSERTER, SEAL	5120-01-362-2026	1U7430
36	F	INSERTER, SEAL	5120-01-362-2027	1U7598
37	F	INSTALLER, SEAL	N/A	J38574
38	F	JACK, LEVELING SUPPORT, VEHICLE	2590-00-231-7418	10876244
38.1	O	KEY, SOCKET HEAD SCREW	5120-01-355-1670	AWML2.5
38.2	F	NOSE ASSEMBLY		99-3307
38.3	O	PLIERS, HOG RING STAPLE	5120-01-413-8837	0012
39	H	PULLER KIT, UNIVERSAL	5180-00-089-3660	A57QB
40	F	PULLER KIT, UNIVERSAL	5180-01-124-1903	1P3075
41	O	REMOVER, ELECTRICAL CONTACT	5120-00-148-9844	MS3448-001B
42	F	RIVETER, BLIND, HAND	5120-01-289-4310	HP-2
42.1	F	RIVETER, BLIND, PNEUMATIC	5130-01-232-4042	245
43	H	RIVETER, YOKE, HAND	5120-01-415-3558	J-39354

Section III. TOOLS AND TEST EQUIPMENT FOR MTV VEHICLES (CONT)

Tool or Test Equipment REF Code	Maintenance Level	Nomenclature	National Stock Number	Tool Number
44	F	SCREWDRIVER ATTACHMENT, SOCKET WRENCH	5120-00-601-6934	LAW120A
45	O	SCREWDRIVER ATTACHMENT, SOCKET WRENCH	5120-01-053-4158	FAM5A
46	O,F,H	SCREWDRIVER ATTACHMENT, SOCKET WRENCH	5120-01-055-1308	ANSIB18.3.2M
47	O	SCREWDRIVER ATTACHMENT, SOCKET WRENCH	5120-01-079-8032	SAM8A
48	O	SCREWDRIVER ATTACHMENT, SOCKET WRENCH	5120-01-160-8862	S 6 HBS
49	O,F	SCREWDRIVER ATTACHMENT, SOCKET WRENCH	5120-01-367-3462	SA10A
49.1	O,F	SCREWDRIVER ATTACHMENT, SOCKET WRENCH	5120-01-367-3483	FA5LE
50	O,F	SCREWDRIVER ATTACHMENT, SOCKET WRENCH	5120-01-367-3497	TMP12A
51	O	SCREWDRIVER ATTACHMENT, SOCKET WRENCH	5120-01-367-3519	F23D
52	O	SCREWDRIVER ATTACHMENT, SOCKET WRENCH	5120-01-367-3526	FP24
53	O	SCREWDRIVER ATTACHMENT, SOCKET WRENCH	5120-01-367-3527	FP32A
54	F,H	SCREWDRIVER ATTACHMENT, SOCKET WRENCH	5120-01-367-3536	FTX40A
55	O	SCREWDRIVER ATTACHMENT, SOCKET WRENCH	5120-01-367-3574	GFA8A
56	O	SEPARATOR, BALL JOINT	5120-01-255-8238	2287
57	F	SETTING TOOL, WINDSHIELD	5120-01-316-4995	CRL216
58	O,F	SHOP EQUIPMENT, AUTOMOTIVE VEHICLE	4910-00-348-7696	SC4910-95CLA02
59	O,F,H	SHOP EQUIPMENT, AUTOMOTIVE VEHICLE	4910-00-754-0650	SC4910-95CLA72
60	O	SHOP EQUIPMENT, AUTOMOTIVE VEHICLE	4910-00-754-0653	SC4910-95CLA73
61	O,F,H	SHOP EQUIPMENT, AUTOMOTIVE VEHICLE	4910-00-754-0654	SC4910-95CLA74
62	F,H	SHOP EQUIPMENT, AUTOMOTIVE VEHICLE	4910-00-754-0705	SC4910-95CLA31
63	F,H	SHOP EQUIPMENT, AUTOMOTIVE VEHICLE	4910-00-754-0706	SC4910-95CLA62
64	O,F,H	SHOP EQUIPMENT, AUTOMOTIVE VEHICLE	4910-00-754-0707	SC4910-95CLA63
65	O,F	SHOP EQUIPMENT, FUEL AND ELECTRICAL	4910-00-754-0714	SC4910-95CLA01
66	F	SLIDER, SPRING COMPRESSOR	4910-01-165-6015	TF-TUN-J500
67	F	SLING, MULTIPLE LEG	3940-00-777-5744	A170
68	H	SOCKET SET, SOCKET WRENCH	5120-01-195-0640	208FA

Section III. TOOLS AND TEST EQUIPMENT FOR MTV VEHICLES (CONT)

Tool or Test Equipment REF Code	Maintenance Level	Nomenclature	National Stock Number	Tool Number
69	F,H	SOCKET, SOCKET WRENCH	5120-01-068-5643	5555M
70	O	SOCKET, SOCKET WRENCH	5120-01-161-5907	GLDH382
71	F	SOCKET, SOCKET WRENCH	5120-01-335-0784	TW321
72	O	SOCKET, SOCKET WRENCH	5120-01-359-9521	TV940009
73	F	SOLDERING AND BRAZING OUTFIT, RESISTANCE HEATING	3439-00-460-7198	SC4940-95-CLB20
74	O	SOLDERING IRON, ELECTRIC	3439-01-036-3308	3112-S3-40W
75	H	STAND, DIFFERENTIAL CARRIER REPAIR	4910-01-085-7729	J3409-D
76	H	STAND, MAINTENANCE, AUTOMOTIVE ENGINE	4910-00-808-3372	J29109
77	F	TOOL, DISTORTER	5120-01-119-1748	5P-7312
78	O,F	TOOL KIT, AUTO FUEL AND ELECTRICAL SYSTEM REPAIR	5180-00-754-0655	SC4910-95CLA50
79	F	TOOL KIT, BODY AND FENDER	5180-00-754-0643	SC5180-90-N34
80	O,F,H	TOOL KIT, GENERAL MECHANIC'S	5180-00-177-7033	SC5180-90-CL-N26
81	F,H	TOOL KIT, GENERAL MECHANIC'S	5180-00-699-5273	SC5180-90-CL-N05
82	F	TOOL KIT, INTERNAL COMBUSTION ENGINE	5180-01-356-8155	1U6680
83	H	TOOL KIT, SLEEVE REPAIR	5180-01-415-5896	4C4462
84	F	TOOL OUTFIT, HYDRAULIC	4940-01-036-5784	SC4940-95-CL-B07
85	O	TOOL, SPRING REMOVAL	5120-01-360-1918	TV940010
86	F	WIRE TWISTER, PLIER	5120-00-542-4171	GGG-W-340
87	F	WRENCH SET, CROWFOOT, RATCHETING	5120-00-293-0013	GGG-W-646
88	F	WRENCH SET, SOCKET	5120-00-148-3706	ANSI-B107.5
89	H	WRENCH SET, SPANNER	5120-00-215-1882	46D7578
90	O	WRENCH, TORQUE, 0-75 LB-IN.	5120-01-112-9532	TQSC6A

Section IV. REMARKS FOR THE MTV VEHICLE

Remarks Code	Remarks
A	Battery service will be in accordance with TM 9-6140-200-14.
B	Repair of tires will be in accordance with TM 9-2610-200-14.

APPENDIX C TOOLS IDENTIFICATION LIST

Section I. INTRODUCTION

C-1. INTRODUCTION

This appendix lists common tools, supplements, and special tools/fixtures that are suggested for maintenance tasks performed at the Unit Maintenance level.

C-2. EXPLANATION OF COLUMNS

a. Column (1) - Item Number. This number is assigned to the entry in the listing and is referenced in the narrative instructions to identify the item, e.g., "Bar, Pry (Item 1, Appendix C)."

b. Column (2) - Item Name. This column contains the nomenclature for the item.

c. Column (3) - National Stock Number. This is the national stock number assigned to the item which you can use to requisition it.

d. Column (4) - Part Number. This provides the Government, manufacturer, or vendor part number for the item.

e. Column (5) - Reference. This column contains the shop catalog (SC), technical manual, or other publication which provides an illustration and description of the item, or lists whether the item is fabricated.

APPENDIX C Section II. TOOLS IDENTIFICATION LIST

(1) ITEM NUMBER	(2) ITEM NAME	(3) NATIONAL STOCK NUMBER	(4) PART NUMBER	(5) REFERENCE
1	ADAPTER, SOCKET WRENCH	5120-00-227-8088	A-A-2172	SC 4910-95-CL-A74
2	ADJUSTING TOOL, BRAKE SHOE	5120-01-154-3029	J34061	SC 4910-95-CL-A74
3	APRON, RUBBER	8145-00-082-6108	MIL-A-41829	SC 4910-95-CL-A74
4	CAPS, VISE JAW	5120-00-221-1506	GGG-C-137	SC 4910-95-CL-A74
5	DISPENSING PUMP, HAND DRIVEN	4930-00-263-9886	43D15069	SC 4910-95-CL-A74
6	DRILL SET, TWIST	5130-00-293-0983	58	SC 4910-95-CL-A74
7	DRILL, PORTABLE, ELECTRIC	5130-00-293-1849	W-D-661	SC 4910-95-CL-A74
8	DRILL, TWIST	5133-01-120-3519		SC 4910-95-CL-A72

Section II. TOOLS IDENTIFICATION LIST (CONT)

(1) ITEM NUMBER	(2) ITEM NAME	(3) NATIONAL STOCK NUMBER	(4) PART NUMBER	(5) REFERENCE
9	FISHING TOOL, PNEUMATIC TIRE VALVE	5120-00-516-4220	991	SC 4910-95-CL-A74
10	GAGE, DEPTH, MICROMETER	5210-00-619-4045	445BZ-6RL	CTA 50-909
11	GAGE, TIRE PRESSURE	4910-01-117-2994	955	SC 4910-95-CL-A72
12	GAGE, WHEEL ALIGNMENT	5210-00-529-1205	WA361	SC 4910-95-CL-A72
13	GLOVES, RUBBER	8415-00-641-4601	ZZ-G-381	SC 4910-95-CL-A74
14	GLOVES, WELDER'S	8415-00-268-7859	A-A-50022	SC 4910-95-CL-A72
15	GOGGLES, INDUSTRIAL	4240-00-052-3776	A-A-1110	SC 4910-95-CL-A74
16	GUN, LUBRICATING	4930-00-253-2478	1142	SC 4910-95-CL-A74
17	HAMMER, HAND	5120-00-224-4130	A-A-1292	SC 4910-95-CL-A74
18	HAMMER, HAND	5120-01-065-9037	57-533	SC 4910-95-CL-A72
19	HOSE ASSEMBLY, NONMETALLIC	4720-00-356-8557	ZZ-H-461	SC 4910-95-CL-A74
20	IRON, TIRE	5120-00-765-8536	T48A	SC 4910-95-CL-A74
21	JACK, HYDRAULIC, HAND	5120-00-224-7330	D120	SC 4910-95-CL-A74
22	MULTIMETER, DIGITAL	6625-01-139-2512	T00377	SC 4910-95-CL-A74
23	MULTIPLIER, TORQUE WRENCH	5120-00-574-9318	292	SC 4910-95-CL-A72
24	PAN, DRAIN	4910-00-387-9592	450	SC 4910-95-CL-A74
25	PAN, WASH	4940-00-617-9859	5582281	SC 4910-95-CL-A72
26	PRESSURE TESTER, RADIATOR	4910-01-170-4929	J24460-01	SC 4910-95-CL-A74
27	PULLER KIT, MECHANICAL	5120-00-313-9496	1178	SC 4910-95-CL-A74
28	PULLER, BATTERY TERMINAL	5120-00-944-4268	21	SC 4910-95-CL-A74
29	RESPIRATOR, AIR FILTER	4240-00-022-2524	GGG-M-125/6	SC 4910-95-CL-A72
30	SCALE, WEIGHING	6670-00-254-4634	AAA-S-133	SC 4910-95-CL-A74
31	SLING, CARGO	1670-00-823-5043	63J4261-13	CTA 50-970
32	SLING, ENDLESS	3940-00-675-5003	PD101-96	CTA 50-970
33	SOCKET SET, IMPACT	5120-01-117-0466	4151MMY	SC 4910-95-CL-A74
34	SOCKET SET, SOCKET WRENCH	5120-01-073-2821	217FMY	SC 4910-95-CL-A74

Section II. TOOLS IDENTIFICATION LIST (CONT)

(1) ITEM NUMBER	(2) ITEM NAME	(3) NATIONAL STOCK NUMBER	(4) PART NUMBER	(5) REFERENCE
35	SOCKET SET, SOCKET WRENCH	5120-01-115-1149	315SIMMY	SC 4910-95-CL-A74
36	SOCKET SET, SOCKET WRENCH	5120-01-117-3876	221FSMY	SC 4910-95-CL-A72
37	SOCKET, SOCKET WRENCH	5120-00-181-6813	5530	SC 4910-95-CL-A74
38	SOCKET, SOCKET WRENCH	5120-00-232-5681	1242	SC 4910-95-CL-A74
39	SOCKET, SOCKET WRENCH	5120-00-243-7351	5316	SC 4910-95-CL-A74
40	SOCKET, SOCKET WRENCH	5120-01-112-0581	SIMM190	SC 4910-95-CL-A74
41	STE/ICE-R	4910-01-222-6589	12259266	SC 4910-95-CL-A74
41.1	TEST KIT, RADIATOR	4910-00-728-8227		SC 4910-95-CL-A74
42	TESTER, ANTIFREEZE AND BATTERY	6630-00-105-1418	10425	SC 4910-95-CL-A74
43	TOOL KIT, AUTO FUEL	5180-00-754-0655		SC 5180-95-CL-A50
44	TOOL KIT, BLIND RIVET	5180-01-201-4978	D-100-MIL-1	SC 4910-95-CL-A74
45	TOOL KIT, ELECTRICAL	5180-00-876-9336	7550526	SC 4910-95-CL-A72
46	TOOL KIT, GENERAL MECHANIC'S	5180-00-177-7033		SC 5180-90-N26
47	TRESTLE, MOTOR VEHICLE MAINTENANCE	4910-00-251-8013	306	SC 4910-95-CL-A74
48	WISE, MACHINIST	5120-00-293-1439	504M2	SC 4910-95-CL-A74
49	WRENCH SET, SOCKET	5120-00-081-2305	GGG-W-641	SC 4910-95-CL-A74
50	WRENCH SET, SOCKET	5120-00-204-1999	GGG-W-641	SC 4910-95-CL-A74
51	WRENCH SET, SOCKET	5120-00-322-6231	51200017510	SC 4910-95-CL-A74
52	WRENCH, ADJUSTABLE	5120-00-264-3793	2117080	SC 4910-95-CL-A74
53	WRENCH, ADJUSTABLE, AUTOMOTIVE	5120-00-449-8083	1B7536	SC 4910-95-CL-A74
54	WRENCH, BOX AND OPEN END	5120-00-277-8833	1244	SC 4910-95-CL-A74
55	WRENCH, BOX AND OPEN END	5120-00-277-8834	GGG-W-636	SC 4910-95-CL-A74
56	WRENCH, PIPE	5120-00-277-1485		SC 4910-95-CL-A74
57	WRENCH, STRAP, ADJUSTABLE	5120-00-020-2947	A91C	SC 4910-95-CL-A74
58	WRENCH, TORQUE, 0-175 lb- ft	5120-00-640-6364	1753LDF	SC 4910-95-CL-A74

Section II. TOOLS IDENTIFICATION LIST (CONT)

(1) ITEM NUMBER	(2) ITEM NAME	(3) NATIONAL STOCK NUMBER	(4) PART NUMBER	(5) REFERENCE
59	WRENCH, TORQUE, 0-200 lb-in.	5120-00-853-4538	F2001	SC 4910-95-CL-A72
59.1	WRENCH, TORQUE, 0-300 lb-in.	5120-00-776-1841	2163993	SC 4910-95-CL-A74
60	WRENCH, TORQUE, 0-600 lb-ft	5120-00-221-7983	SW130-301	SC 4910-95-CL-A72

APPENDIX D EXPENDABLE/DURABLE SUPPLIES AND MATERIALS LIST

Section I. INTRODUCTION

D-1. SCOPE

This appendix lists expendable and durable items that you will need to operate and maintain the MTV vehicle. This listing is for information only and is not authority to requisition the listed items. These items are authorized to you by CTA 50-970, Expendable/Durable Items (except medical, class V repair parts, and heraldic items), or CTA 8-100, Army Medical Department Expendable/Durable Items.

D-2. EXPLANATION OF COLUMNS

- a. **Column (1) - Item Number.** This number is assigned to the entry in the listing and is referenced in the narrative instructions to identify the item, e.g., "Oil, Lubricating (Item 25, Appendix D).
- b. **Column (2) - Level.** This column identifies the lowest level of maintenance that requires the item.
- c. **Column (3) - National Stock Number.** This is the national stock number assigned to the item which you can use to requisition it.
- d. **Column (4) - Item Name, Description, Commercial and Government Entity Code (CAGEC), and Part Number.** This provides the other information you need to identify the item.
- e. **Column (5) - Unit of Measure.** This code shows the physical measurement or count of an item, such as gallon, dozen, gross, etc.

Section II. EXPENDABLE/DURABLE SUPPLIES AND MATERIALS LIST

(1) Item Number	(2) Level	(3) National Stock Number	(4) Description	(5) U/M
1	O	4730-00-248-9340	Adapter, Pipe to Tube (81343) 4-4 010103B	ea
1.1	O	4730-01-453-9651	Adapter, Straight, Pipe to Boss (19207) 12421890-001	ea
1.2	O	4730-01-457-4025	Adapter, Straight, Pipe to Tube (96906) MS51503B4-4	ea
1.3	O	4730-00-760-3525	Adapter, Straight, Tube to Boss (81361) C116-3-71	ea
2	O	8040-00-273-8717	Adhesive (81348) MMM-A-121	pt
3	O	8040-00-152-0063	Adhesive (81348) MMM-A-1617 TY3	bt
4	O	8040-01-250-3969	Adhesive (05972) 242	ea
5	O	8040-00-117-8510	Adhesive (71984) 3145 RTV Clear	tu
6	O	8040-00-776-9602	Adhesive (73168) 80055-31	kt
7	O	8040-00-522-3429	Adhesive (81349) (MIL-A-46106)	oz

Section II. EXPENDABLE/DURABLE SUPPLIES AND MATERIALS LIST (CONT)

(1) Item Number	(2) Level	(3) National Stock Number	(4) Description	(5) U/M
8	O	8040-00-118-2695	Adhesive (72799) RTV162	kt
9	O	8040-01-331-7473	Adhesive (81349) (MIL-A-46106 GP3TY1)	tu
10	O	8040-01-331-7470	Adhesive (81349) MIL-A-46106 5 oz tube	oz
10.1	O	8040-01-446-7842	Adhesive (01139) RTV123	ca
10.2	O	8040-00-728-3088	Adhesive (78500) 1199-T-3842 6 oz	kt
11	C	6850-00-174-1806	Antifreeze, Arctic Type (81349) (MIL-A-11755) 55 gl drum	dr
12	C	6850-00-181-7940	Antifreeze, Ethylene Glycol, Permanent (81349) (MIL-A-46153) 55 gl drum	dr
13	O	8030-00-597-5367	Antiseize Compound (81349) (MIL-A-907)	lb
13.1	O	5340-01-454-4336	Bracket, Angle (0FW39) 12421859-001	ea
14	O	5340-00-450-5718	Cap and Plug Set (19207) 10935405	ea
14.1	O	5340-01-423-0972	Clamp, Loop (18076) S630H-20	ea
14.2	O	5340-01-377-6171	Clamp, Loop (18076) 5630H-24	ea
15	O	6850-00-926-2275	Cleaning Compound, Windshield (81349) O-C-1901 16 oz bottle	bt
16	O	7920-00-044-9281	Cloth, Cleaning (81349) (MIL-C-85043)	bx
17	O		Corrosion Preventive Compound (81349) (MIL-C-16173)	
		8030-00-062-6950	Grade 1 - 1 qt can	qt
		8030-01-149-1731	Grade 2 - 1 qt can	qt
		8030-00-837-6557	Grade 3 - 1 pt can	pt
		8030-00-903-0931	Grade 4 - 1 pt can	pt
18	O	8030-00-033-4291	Corrosion Preventive Compound (81349) (MIL-C-82594) 8 oz can	bt
18.1	O	2540-01-460-8048	Cover, Seat, Vehicular (27797) WM1058	ea
18.2	O	2540-01-463-8394	Cover, Seat, Vehicular (0FW39) WM1059	ea
19	C	9150-00-024-9621	Damping Fluid (81348) VV-D-1078	pt
20	O	7520-01-209-1152	Dispenser, Pressure Sensitive Adhesive Tape (75037) STD-0-9	ea
20.1	O	4730-01-454-1233	Elbow, Pipe to Boss (19207) 12421891-001	ea
20.2	O	4730-00-863-9098	Elbow, Pipe to Tube (30780) 4VBTXB	ea
21	O	5330-01-325-6993	Gasket Forming Compound (05972) 515	ea

Section II. EXPENDABLE/DURABLE SUPPLIES AND MATERIALS LIST (CONT)

(1) Item Number	(2) Level	(3) National Stock Number	(4) Description	(5) U/M
22	O	9150-01-197-7688 9150-01-197-7690 9150-01-197-7689 9150-01-197-7692	Grease, Automotive and Artillery (GAA) (81349) (MIL-G-10924) 2-1/4 oz tube 1.75 lb can 6.5 lb can 35 lb can	tu cn cn cn
23	O	9150-00-180-6382	Grease, General Purpose (81349) MIL-T-24139 6.5 lb can	lb
24	O	9150-00-935-4018	Grease, Molybdenum Disulfide (81349) (MIL-G-21164)	ca
24.1	O	4720-01-469-9208	Hose Assembly, Nonmetallic (0FW39) 12418004-002	ea
24.2	O		Hose Assembly (0FW39) 12421278-003	ea
24.3	O		Hose Assembly (0FW39) 12421858-002	ea
24.4	O		Hose Assembly (0FW39) 12421858-003	ea
24.5	O		Hose Assembly (0FW39) 12421858-004	ea
24.6	O		Hose Assembly (0FW39) 12421858-005	ea
24.7	O	4720-01-384-0995	Hose Assembly, Nonmetallic (19207) 12421858-006	ea
24.8	O		Hose Assembly (0FW39) 12421927-001	ea
24.9	O		Hose Assembly (0FW39) 12421927-002	ea
24.10	O		Hose Assembly (0FW39) 12421927-003	ea
24.11	O	4720-01-469-9266	Hose Assembly, Nonmetallic (0FW39) 12421927-004	ea
24.12	O		Hose Assembly (0FW39) 12421991	ea
24.13	O	4720-00-988-3842	Hose Assembly, Nonmetallic (50599) R25679-1	ea
25	C	9150-00-252-6383 9150-00-223-4134	Hydraulic Fluid A (81349) (MIL-H-5606) 1 qt can 1 gl can	cn cn
26	O	7510-00-145-0559	Ink, Marking Stencil (81349) (MIL-I-43553)	oz
27	O	7510-01-386-0787	Inking Pad, Rubber Stamp (88001) 0603A	ea
28	O	5970-01-100-4464	Insulating Compound, Electrical (08800) RTV-102WHITE	tu
28.1	O	5970-01-378-3018	Insulation Sleeving, Electrical (06090) ATUM-1/4-0-4FT	lg
29	O	5970-00-838-5951	Insulation Sleeving, Electrical (06090) CRN3-16BLACK	ft

Section II. EXPENDABLE/DURABLE SUPPLIES AND MATERIALS LIST (CONT)

(1) Item Number	(2) Level	(3) National Stock Number	(4) Description	(5) U/M
30	O	1650-00-166-4834	Lockwire (90166) 68A32	ea
31	O	9150-01-360-1905	Lubricant, Solid Film (81349) (MIL-L-46147) 16 oz can	cn
31.1	O		Modification Kit, Junction Box 6-576-100041 (12361)	ea
32	O	4730-00-019-0608	Nipple, Pipe (81996) A2303-12-52PC102	ea
33	O	4730-00-825-7304	Nipple, Tube (96906) MS51501B4	ea
34	O	5310-00-059-4265	Nut, Plain, Hex (89346) 98881R1	ea
34.1	C		Oil, Commercial Burner Fuel, Grade FO-1 (ASTM D396)	
34.2	C		Oil, Commercial Burner Fuel, Grade FO-2 (ASTM D396)	
35	C		Oil, Fuel, Diesel, DF-A Arctic (81348) (VV-F-800)	
		9140-00-286-5282	5 gl can	cn
		9140-00-286-5283	Bulk	gl
		9140-00-286-5284	55 gl drum, 16 gauge	dr
		9140-00-286-5285	55 gl drum, 18 gauge	dr
36	C		Oil, Fuel, Diesel, DF-1, Winter (81348) (VV-F-800)	
		9140-00-286-5286	Bulk	gl
		9140-00-286-5287	5 gl can	cn
		9140-00-286-5288	55 gl drum, 16 gauge	dr
		9140-00-286-5289	55 gl drum, 18 gauge	dr
37	C		Oil, Fuel, Diesel, DF-2, Regular (81348) (VV-F-800)	
		9140-00-286-5294	Bulk	gl
		9140-00-286-5295	Can	cn
		9140-00-286-5296	55 gl drum, 16 gauge	dr
		9140-00-286-5297	55 gl drum, 18 gauge	dr
38	C		Oil, Lubricating, Arctic (81349) (MIL-L-46167)	
		9150-00-402-2372	5 gl can	cn
		9150-00-491-7197	55 gl drum	dr
39	C		Oil, Lubricating, Gear, GO 75W (81349) (MIL-L-2105)	
		9150-01-035-5390	1 qt can	cn
		9150-01-035-5391	5 gl can	cn
40	C		Oil, Lubricating, Gear, 80W-90 (81349) (MIL-L-2105)	
		9150-01-035-5392	1 qt can	qt
		9150-01-035-5393	5 gl can	cn
		9150-01-035-5394	55 gl drum, 16 gauge	dr

Section II. EXPENDABLE/DURABLE SUPPLIES AND MATERIALS LIST (CONT)

(1) Item Number	(2) Level	(3) National Stock Number	(4) Description	(5) U/M
41	O	9150-01-048-4591 9150-01-035-5395 9150-01-035-5396	Oil, Lubricating, Gear, 85W-140 (81349) (MIL-L-2105) 1 qt can 5 gl can 55 gl drum	qt cn dr
42	C	9150-00-183-7807 9150-00-186-6668 9150-00-191-2772	Oil, Lubricating, OE/HDO 10 (81349) (MIL-L-2104) Bulk 5 gl can 55 gl drum	gl cn dr
43	C	9150-00-189-6727	Oil, Lubricating, OE/HDO 10W (81349) (MIL-L-2104) 1 qt can	cn
44	C	9150-01-152-4117 9150-01-152-4118 9150-01-152-4119	Oil, Lubricating, OE/HDO 15W-40 (81349) (MIL-L-2104) 1 qt can 5 gl can 55 gl drum	cn cn dr
45	C	9150-00-183-7808 9150-00-186-6681 9150-00-188-9858 9150-00-189-6729	Oil, Lubricating, OE/HDO 30 (SAE 30) (81349) (MIL-L-2104) Bulk 1 qt can 5 gl can 55 gl drum, 18 gauge	gl cn cn dr
46	C	9150-00-405-2987 9150-00-189-6730 9150-00-188-9862	Oil, Lubricating, OE/HDO 40 (81349) (MIL-L-2104) Bulk 1 qt can 5 gl can	gl cn cn
47	O	5350-00-067-7639	Paper, Abrasive (28124) 02347 pg contains 100 sheets	pg
48	O	8010-01-146-2650	Polyurethane Coating (81349) (MIL-C-46168)	kt
49	O	8030-00-181-8372	Primer, Sealing Compound (05972) 747-56	cn
50	C	7920-00-205-1711	Rag, Wiping (64067) 7920-00-205-1711 50 lb bale	be
51		DELETED		
52	O	4020-00-106-9342	Rope, Nylon (81349) (MIL-R-24050)	ro
53	O	7520-00-634-2442	Rubber Stamp Set, Fixed Type (02663) W-5-3/8-AZ SET	ea
53.1	O	5305-01-299-4602	Screw, Cap, Hex Hd (64678) 000933 006058	ea
53.2	O	5305-01-454-5938	Screw, Cap, Hex Hd (19207) 12419954-093	ea
53.3	O	5305-00-021-3740	Screw, Cap, Hex Hd (97942) 645A560H43	ea

Section II. EXPENDABLE/DURABLE SUPPLIES AND MATERIALS LIST (CONT)

(1) Item Number	(2) Level	(3) National Stock Number	(4) Description	(5) U/M
54	O	5305-01-296-0019	Screw, Cap, Socket Head (06888) SHCM75275 50 ct box	bx
54.1	O	8030-01-157-0988	Sealing Compound (83574) PR-1422 A-1/2 6 oz	ca
54.2	O	8030-01-371-8405	Sealing Compound (83574) PR-1422 B-1/2 6 oz	ca
55	O	8030-00-111-2762	Sealing Compound (05972) 290-31	bt
56	O	8030-00-133-3164	Sealing Compound (05972) 571-31	bt
57	O	8030-00-148-9833	Sealing Compound (05972) 271-21	bx
58	O	8030-00-204-9149	Sealing Compound (05972) 592-41	tu
59	O	8030-00-656-1426	Sealing Compound (81349) (MIL-S-45180)	pt
60	O	8030-01-025-1692	Sealing Compound (05972) 242-41 (MIL-S-46163)	bt
61	O	8030-01-088-8140	Sealing Compound (52571) 9001512-0011	bt
62	O	8030-01-155-3238	Sealing Compound (11083) 6V6640	ml
63	C	7930-00-634-3935	Soap, Laundry (81348) P-S-1792	lb
64	O	3439-00-006-7764	Solder, Tin Alloy (81348) SN63WRAP3 1 lb spool	sl
65	C	6850-00-281-1985 6850-00-664-5685	Solvent, Dry Cleaning SD (P-D-680) 1 gl can 1 qt can	cn cn
65.1	O		Strap, Tiedown, Electrical Components (06383) PLP2S	ea
65.2	O	9320-01-244-0046	Tape, Adhesive, Rubber (18876) MIS-41157-08 180 ft	ro
66	O	8030-00-889-3534	Tape, Antiseizing (81349) (MIL-T-27730)	ea
67	O	5640-00-103-2254	Tape, Duct (39428) 1791K70	ea
68	O	5970-00-644-3167	Tape, Insulation, Electrical (80063) TL83	ro
68.1	O	4730-00-138-8050	Tee, Pipe (81343) 8-8-8 140424C	ea
69	O	5975-01-379-4997	Ties, Cable, Plastic (06383) PLT 35-C-O	hd
69.1	C		Turbine Fuel, Aviation, Kerosene Type (MIL-T-83133), Grade JP-8	
69.2	C	9140-00-255-7764 9140-00-273-2378 9140-00-273-2377	Turbine Fuel, (MIL-F-16884), (NATO Code No. F75 or F-72) 5 gl can 55 gl drum 1 gl can	cn dr cn

Section II. EXPENDABLE/DURABLE SUPPLIES AND MATERIALS LIST (CONT)

(1) Item Number	(2) Level	(3) National Stock Number	(4) Description	(5) U/M
69.3	C	9130-00-273-2380	Turbine Fuel, (MIL-F-5624), Grade JP-4 (NATO Code No. F40) Drum, 16 gage	dr
69.4	C	9130-01-305-5596 9130-01-250-6353	Turbine Fuel, (MIL-T-5624), Grade JP-5 (NATO Code No. F-44) Bulk Drum, 16 gage	gl dr
70	O	8010-00-180-6343	Varnish, Oil (23667) 515320	pt
71	O	6145-01-148-2263	Wire, Electrical (80009) 175-0825-00 50 ft	ft
72	O	9505-00-555-8648	Wire, Nonelectrical (96906) MS20995C47 5 lb spool	sl

APPENDIX E

ILLUSTRATED LIST OF MANUFACTURED ITEMS

Section I. INTRODUCTION

E-1. INTRODUCTION

This appendix includes complete instructions for manufacturing or fabricating authorized items locally. All bulk materials needed to manufacture an item are listed by part number or specification number. Figures are provided as needed. See standards and specifications DoD-Std-00100D(AR) and ANSI Y14.5M1982 for required details.

Section II. MANUFACTURED ITEMS INDEX

ITEM NAME/PART NUMBER	ITEM DESCRIPTION	PARA NO.
Brake Adjusting Tool Support		E-2
Brake Plunger Seal Driver		E-3
Cab Support Tool		E-4
Dump Body Lifting Bracket		E-5
Headlight Adjustment Screen		E-6
M1089 30K Winch Test Adapter		E-7
M1089 Solenoid Test Adapter		E-8
Relay Test Wire		E-9
Transmission Auxiliary Oil Cooler Rubber Seal		E-10
Wheel Bearing Shim Tool Rest		E-11
12414690-001	Pneumatic Tube	E-12
12414690-002	Pneumatic Tube	E-12
12414690-003	Pneumatic Tube	E-12
12414690-004	Pneumatic Tube	E-12
12414690-005	Pneumatic Tube	E-12
12414690-006	Pneumatic Tube	E-12
12414690-007	Pneumatic Tube	E-12
12414690-008	Pneumatic Tube	E-12
12414690-009	Pneumatic Tube	E-12
12414690-010	Pneumatic Tube	E-12
12414690-101	Pneumatic Tube	E-12
12414690-102	Pneumatic Tube	E-12
12414690-103	Pneumatic Tube	E-12
12414690-104	Pneumatic Tube	E-12
12414690-105	Pneumatic Tube	E-12
12414690-106	Pneumatic Tube	E-12
12414690-107	Pneumatic Tube	E-12
12414690-108	Pneumatic Tube	E-12
12414690-109	Pneumatic Tube	E-12
12414690-112	Pneumatic Tube	E-12
12414690-113	Pneumatic Tube	E-12
12414690-115	Pneumatic Tube	E-12
12414690-118	Pneumatic Tube	E-12
12414690-120	Pneumatic Tube	E-12
12414690-125	Pneumatic Tube	E-12
12414690-128	Pneumatic Tube	E-12
12414690-129	Pneumatic Tube	E-12
12414690-130	Pneumatic Tube	E-12

Section II. MANUFACTURED ITEMS INDEX (CONT)

ITEM NAME/PART NUMBER	ITEM DESCRIPTION	PARA NO.
12414690-131	Pneumatic Tube	E-12
12414690-132	Pneumatic Tube	E-12
12414690-133	Pneumatic Tube	E-12
12414690-134	Pneumatic Tube	E-12
12414690-135	Pneumatic Tube	E-12
12414690-136	Pneumatic Tube	E-12
12414690-137	Pneumatic Tube	E-12
12414690-138	Pneumatic Tube	E-12
12414690-139	Pneumatic Tube	E-12
12414690-140	Pneumatic Tube	E-12
12414690-141	Pneumatic Tube	E-12
12414690-142	Pneumatic Tube	E-12
12414690-143	Pneumatic Tube	E-12
12414690-144	Pneumatic Tube	E-12
12414690-145	Pneumatic Tube	E-12
12414690-146	Pneumatic Tube	E-12
12414690-147	Pneumatic Tube	E-12
12414690-148	Pneumatic Tube	E-12
12414690-149	Pneumatic Tube	E-12
12414690-150	Pneumatic Tube	E-12
12414690-151	Pneumatic Tube	E-12
12414690-152	Pneumatic Tube	E-12
12414690-153	Pneumatic Tube	E-12
12414690-154	Pneumatic Tube	E-12
12414690-155	Pneumatic Tube	E-12
12414690-156	Pneumatic Tube	E-12
12414690-157	Pneumatic Tube	E-12
12414690-158	Pneumatic Tube	E-12
12414690-159	Pneumatic Tube	E-12
12414690-160	Pneumatic Tube	E-12
12414690-161	Pneumatic Tube	E-12
12414690-162	Pneumatic Tube	E-12
12414690-163	Pneumatic Tube	E-12
12414690-164	Pneumatic Tube	E-12
12414690-165	Pneumatic Tube	E-12
12414690-166	Pneumatic Tube	E-12
12414690-167	Pneumatic Tube	E-12
12414690-168	Pneumatic Tube	E-12
12414690-169	Pneumatic Tube	E-12
12414690-201	Pneumatic Tube	E-12
12414690-202	Pneumatic Tube	E-12
12414690-203	Pneumatic Tube	E-12
12414690-205	Pneumatic Tube	E-12
12414690-206	Pneumatic Tube	E-12
12414690-207	Pneumatic Tube	E-12
12414690-208	Pneumatic Tube	E-12
12414690-209	Pneumatic Tube	E-12
12414690-210	Pneumatic Tube	E-12
12414690-211	Pneumatic Tube	E-12
12414690-212	Pneumatic Tube	E-12
12414690-215	Pneumatic Tube	E-12

ITEM NAME/PART NUMBER	ITEM DESCRIPTION	PARA NO.
12414690-216	Pneumatic Tube	E-12
12414690-217	Pneumatic Tube	E-12
12414690-218	Pneumatic Tube	E-12
12414690-219	Pneumatic Tube	E-12
12414690-220	Pneumatic Tube	E-12
12414690-221	Pneumatic Tube	E-12
12414690-222	Pneumatic Tube	E-12
12414690-223	Pneumatic Tube	E-12
12414690-224	Pneumatic Tube	E-12
12414690-225	Pneumatic Tube	E-12
12414690-228	Pneumatic Tube	E-12
12414690-229	Pneumatic Tube	E-12
12414690-230	Pneumatic Tube	E-12
12414690-231	Pneumatic Tube	E-12
12414690-232	Pneumatic Tube	E-12
12414690-233	Pneumatic Tube	E-12
12414690-234	Pneumatic Tube	E-12
12414690-235	Pneumatic Tube	E-12
12414690-236	Pneumatic Tube	E-12
12414690-237	Pneumatic Tube	E-12
12414690-238	Pneumatic Tube	E-12
12414690-239	Pneumatic Tube	E-12
12414690-240	Pneumatic Tube	E-12
12414690-241	Pneumatic Tube	E-12
12414690-242	Pneumatic Tube	E-12
12414690-243	Pneumatic Tube	E-12
12414690-244	Pneumatic Tube	E-12
12414690-245	Pneumatic Tube	E-12
12414690-246	Pneumatic Tube	E-12
12414690-247	Pneumatic Tube	E-12
12414690-248	Pneumatic Tube	E-12
12414690-249	Pneumatic Tube	E-12
12414690-301	Pneumatic Tube	E-12
12414690-302	Pneumatic Tube	E-12
12414690-303	Pneumatic Tube	E-12
12416381P1	Non-Metallic Electrical Cable Conduit	E-13
12416381P10	Non-Metallic Electrical Cable Conduit	E-13
12416381P11	Non-Metallic Electrical Cable Conduit	E-13
12416381P12	Non-Metallic Electrical Cable Conduit	E-13
12416381P13	Non-Metallic Electrical Cable Conduit	E-13
12416381P14	Non-Metallic Electrical Cable Conduit	E-13
12416381P15	Non-Metallic Electrical Cable Conduit	E-13
12416381P16	Non-Metallic Electrical Cable Conduit	E-13
12416381P17	Non-Metallic Electrical Cable Conduit	E-13
12416381P2	Non-Metallic Electrical Cable Conduit	E-13
12416381P20	Non-Metallic Electrical Cable Conduit	E-13
12416381P21	Non-Metallic Electrical Cable Conduit	E-13
12416381P22	Non-Metallic Electrical Cable Conduit	E-13
12416381P23	Non-Metallic Electrical Cable Conduit	E-13
12416381P26	Non-Metallic Electrical Cable Conduit	E-13
12416381P3	Non-Metallic Electrical Cable Conduit	E-13
12416381P30	Non-Metallic Electrical Cable Conduit	E-13
12416381P32	Non-Metallic Electrical Cable Conduit	E-13

Section II. MANUFACTURED ITEMS INDEX (CONT)

ITEM NAME/PART NUMBER	ITEM DESCRIPTION	PARA NO.
12416381P34	Non-Metallic Electrical Cable Conduit	E-13
12416381P35	Non-Metallic Electrical Cable Conduit	E-13
12416381P36	Non-Metallic Electrical Cable Conduit	E-13
12416381P37	Non-Metallic Electrical Cable Conduit	E-13
12416381P38	Non-Metallic Electrical Cable Conduit	E-13
12416381P4	Non-Metallic Electrical Cable Conduit	E-13
12416381P5	Non-Metallic Electrical Cable Conduit	E-13
12416381P6	Non-Metallic Electrical Cable Conduit	E-13
12416381P7	Non-Metallic Electrical Cable Conduit	E-13
12416381P8	Non-Metallic Electrical Cable Conduit	E-13
12416381P9	Non-Metallic Electrical Cable Conduit	E-13
12418037	Steering Gear Return Hose	E-14
12418460-001	Transmission Oil Cooler Hose	E-14
12418460-002	Transmission Oil Cooler Hose	E-14
12418763	Lanyard Assembly	E-15
12420196	Lanyard Assembly	E-15
12420197-001	Non-Metallic Vent Air Hose	E-16
12420197-002	Non-Metallic Vent Air Hose	E-16
12420197-003	Non-Metallic Vent Air Hose	E-16
12420197-004	Non-Metallic Vent Air Hose	E-16
12420197-005	Non-Metallic Vent Air Hose	E-16
12420197-006	Non-Metallic Vent Air Hose	E-16
12420198-001	Non-Metallic Vent Air Hose	E-16
12420198-002	Non-Metallic Vent Air Hose	E-16
12420308-457	Personnel Heater Air Duct Hose	E-17
12420308-760	Personnel Heater Air Duct Hose	E-17
12420489	Block Seal	E-18
3256-H-1048	CTIS Seal Driver	E-19
3256-K-1051	Wheel Hub Grease Seal Driver	E-20
Dimmer Switch Test Wire		E-21
Purge Valve Tool		E-22
M1089 30K Winch Air Hoses		E-23
M1089 30K Winch Pneumatic Test Adapter		E-24

Section III. MANUFACTURED ITEMS

E-2. BRAKE ADJUSTING TOOL SUPPORT

Make the brake adjusting tool support from 0.134 in. (3.4 mm) flat steel stock according to the following instructions. Refer to the parts list and **Figure E-1. Brake Adjusting Tool Support** for details.

Item	Part Number	Material Description	Size	Qty
1	N/A	Steel, ASTM A569 Sheet, Hot Rolled	6.0 in. (152.4 mm) x 6.0 in. (152.4 mm) x 0.134 in. (3.4 mm)	2

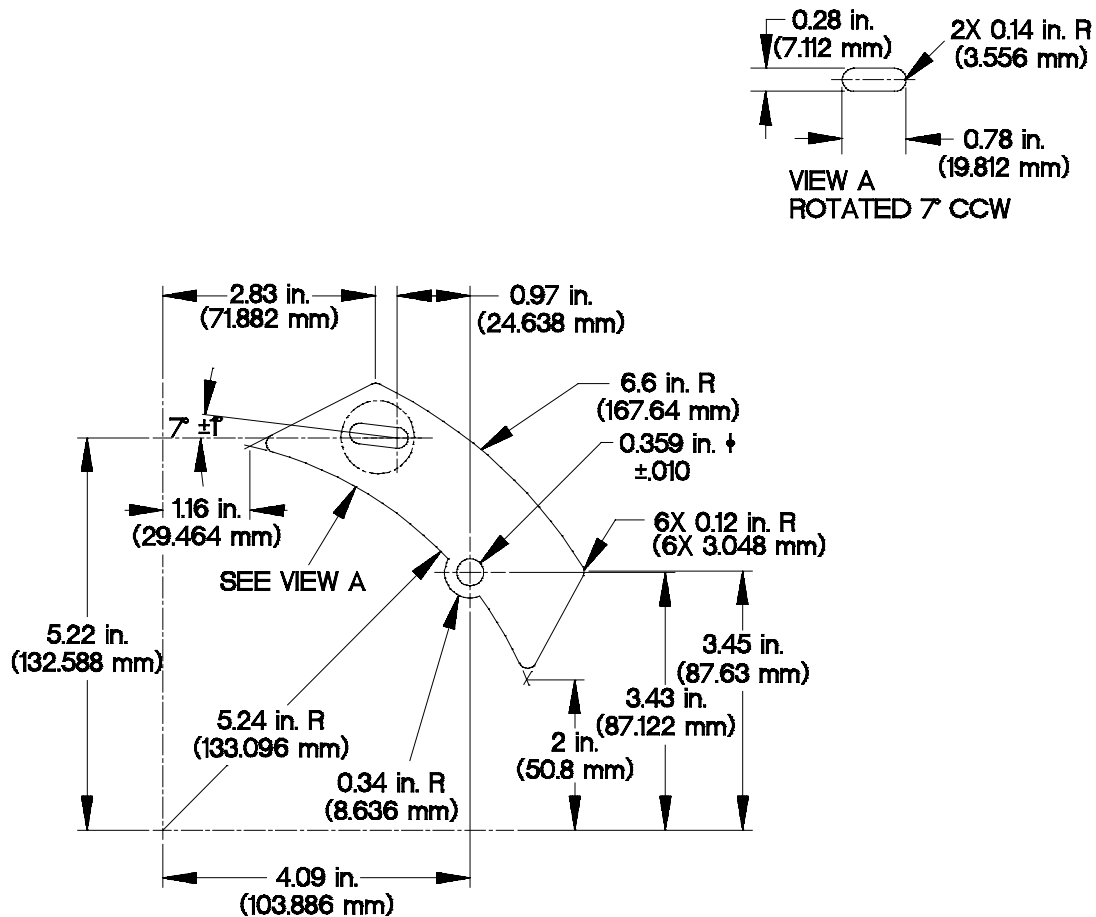

YAPPD011

Figure E-1. Brake Adjusting Tool Support

- a. All dimensions are in inches (millimeters).
- b. Cut steel sheet as shown by dimensions on **Figure E-1. Brake Adjusting Tool Support**.
- c. De-burr and remove sharp edges.

E-3. BRAKE PLUNGER SEAL DRIVER

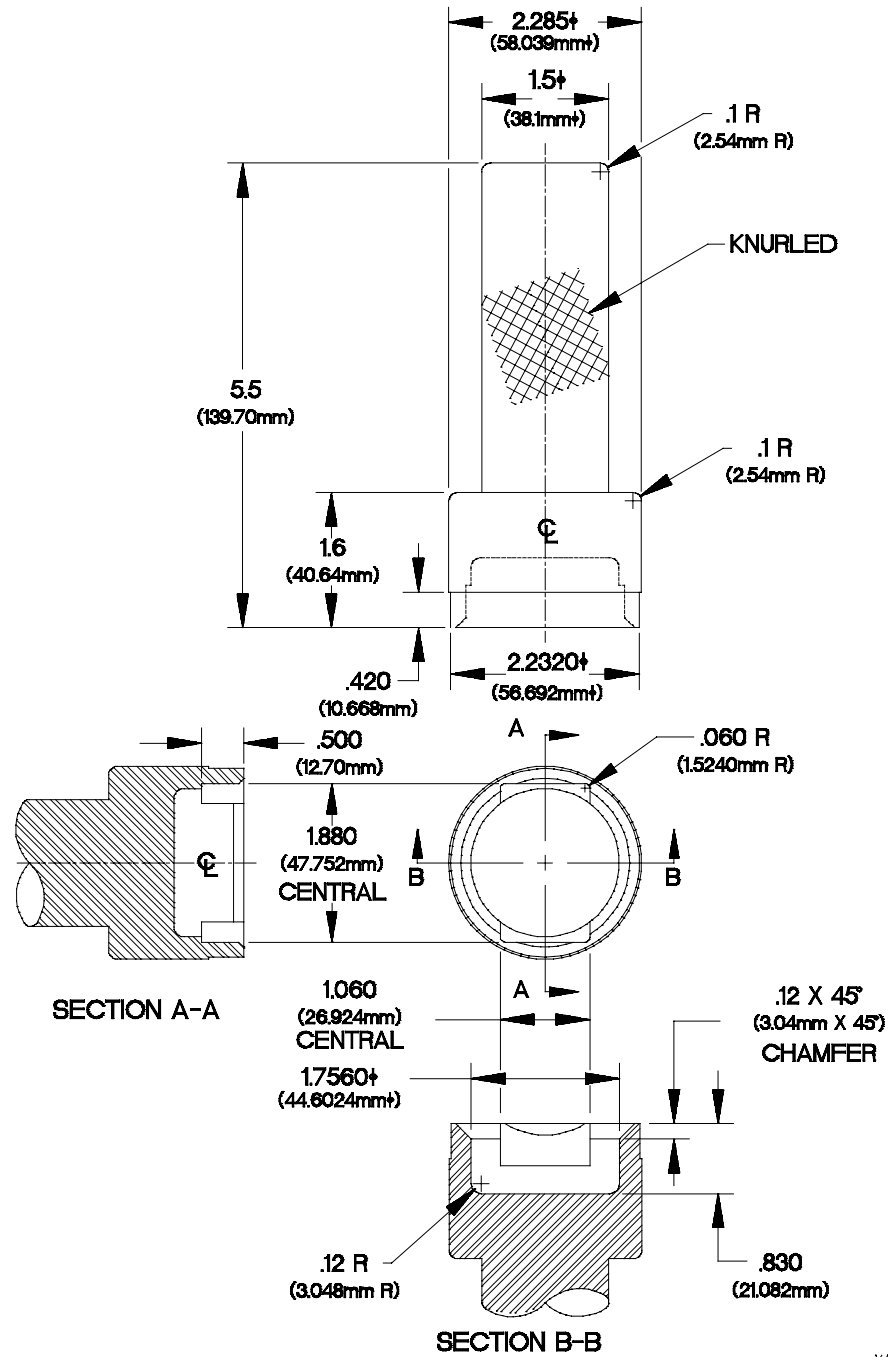

XAPPE021

Figure E-2. Brake Plunger Seal Driver

- a. All dimensions are in inches (millimeters).
- b. Manufacture from round steel stock.
- c. De-burr and remove sharp edges.

E-4. CAB SUPPORT TOOL

Make the cab support tool from .38 inch (.96 cm) flat steel stock and angle iron stock according to the following instructions. Refer to the parts list and **Figure E-3. Cab Support Tool Strut and Cab Rest** for details.

Item	Part Number	Material Description	Size	Qty
1	N/A	Steel, Flat Bar	4.0 in. (10.2 cm) X 33.38 in. X (84.8 cm) X 0.38 in. (0.96 cm)	1
2	N/A	Steel, Flat Bar	4.0 in. (10.2 cm) X 12.0 in. (30.5 cm) X 0.38 in. (0.96 cm)	1
3	N/A	Angle Iron	2.0 in. (5.1 cm) X 2.0 in. (5.1 cm) X 3.5 in. (8.9 cm)	2
4	H.S.105VW-1	Insulgrip, CSA 105 C		

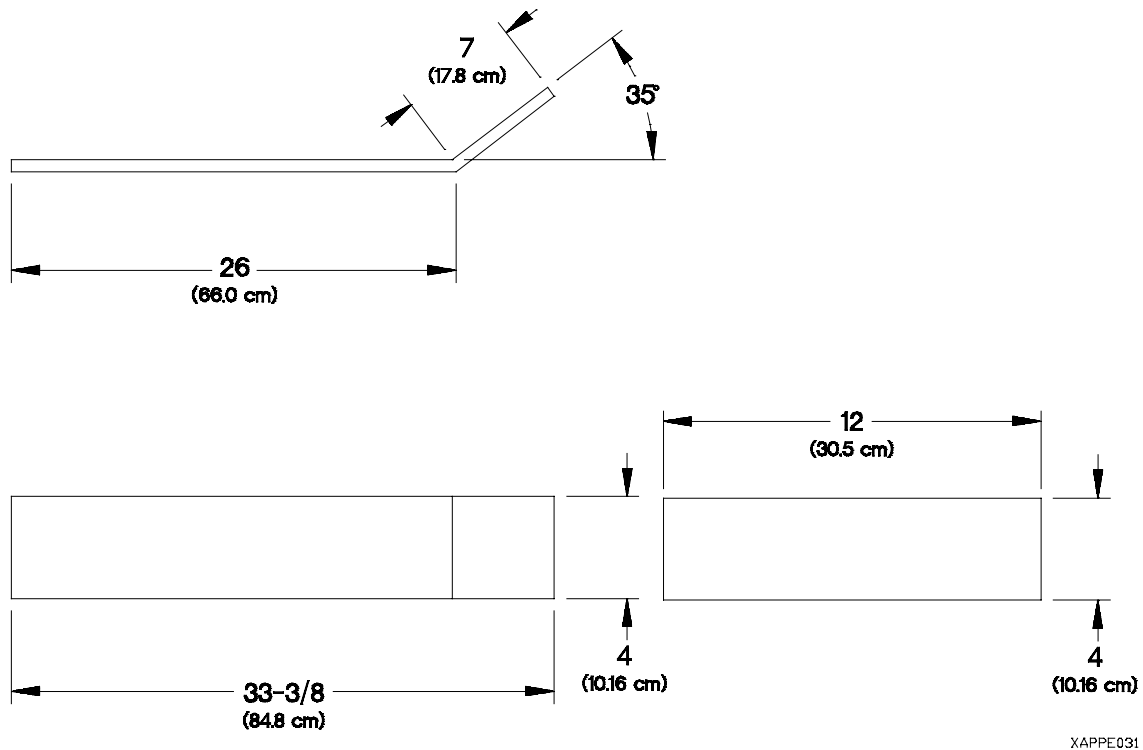

XAPPE031

Figure E-3. Cab Support Tool Strut and Cab Rest

- a. All dimensions are in inches (centimeters).
- b. Cut cab support tool strut (1) from steel flat bar and bend to shape as shown in **Figure E-3. Cab Support Tool Strut and Cab Rest**.
- c. Cut cab support tool cab rest (2) from steel flat bar.
- d. De-burr and remove sharp edges.

E-4. CAB SUPPORT TOOL (CONT)

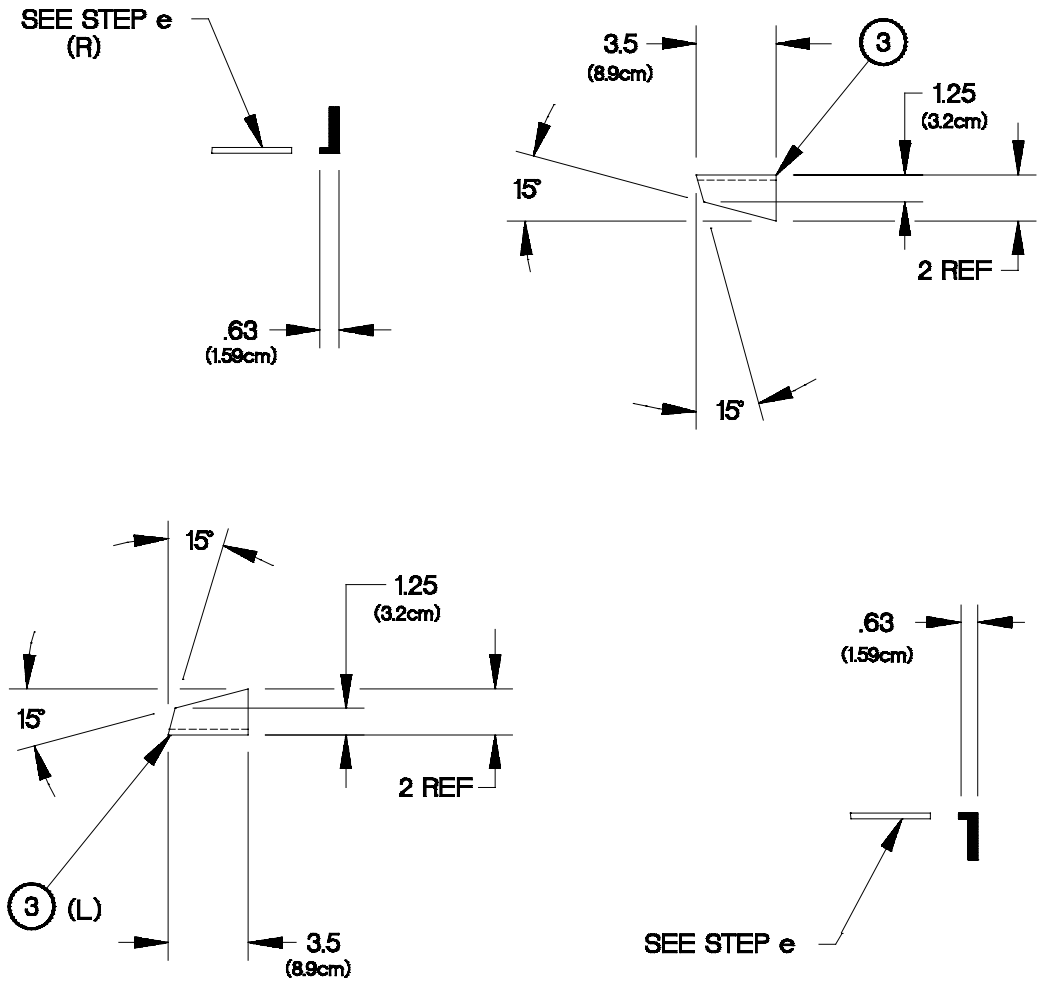

XAPPE041

Figure E-4. Cab Support Tool Seat

- e. Remove flange side of cab support tool seats (3) as shown in **Figure E-4. Cab Support Tool Seat**.
- f. Cut cab support tool seats (3) L and (3) R according to dimensions and left/right orientation shown on **Figure E-4. Cab Support Tool Seat**.
- g. De-burr and remove sharp edges.

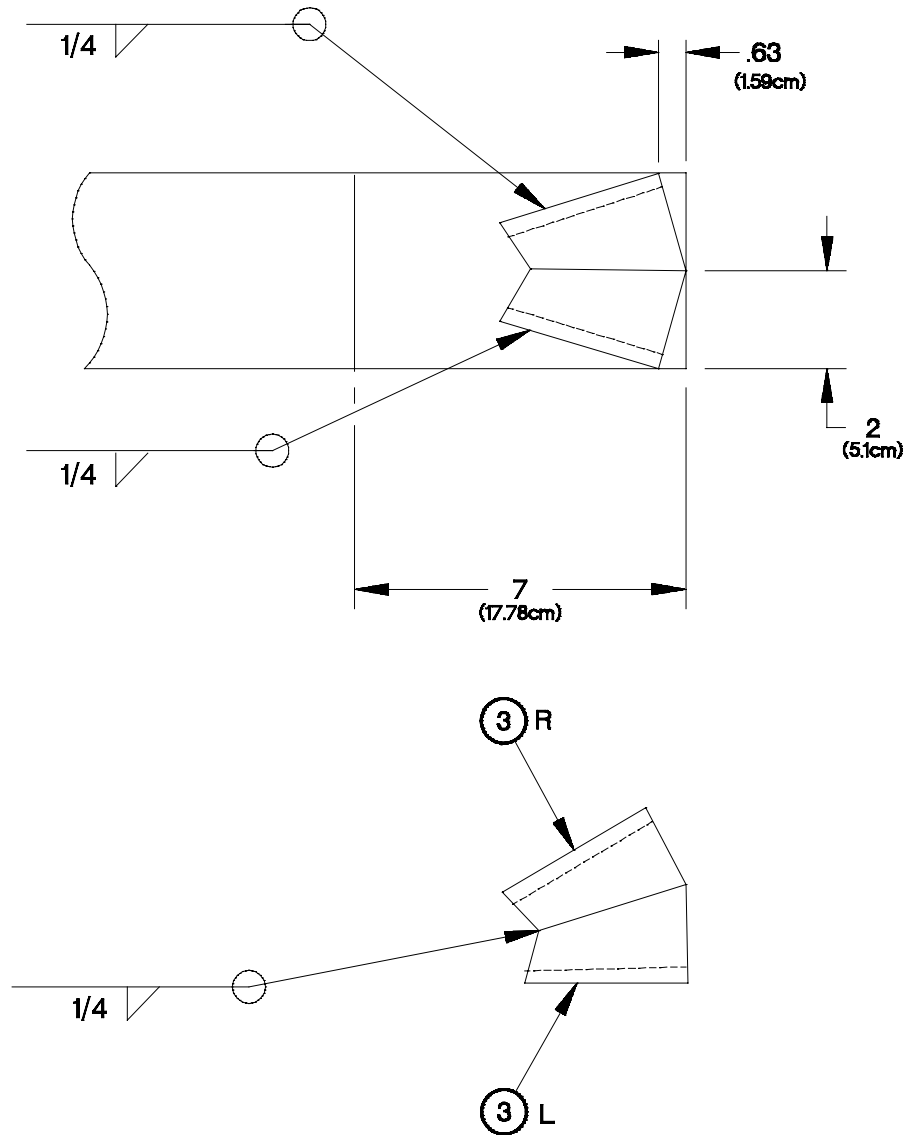

XAPPE051

Figure E-5. Cab Support Tool Seat Layout

- h. Position and clamp cab support tool seats (3) L and (3) R together as shown by dimensions on **Figure E-5. Cab Support Tool Seat Layout**.
- i. Weld cab support tool seat (3) L to cab support tool seat (3) R as identified on assembly table and **Figure E-5. Cab Support Tool Seat Layout**.
- j. Position and clamp cab support tool seats (3) L and (3) R to cab support tool strut (1) as shown by dimensions on **Figure E-5. Cab Support Tool Seat Layout**.
- k. Weld items clamped in step (f) as shown in **Figure E-5. Cab Support Tool Seat Layout**.
- l. De-burr and remove sharp edges.

E-4. CAB SUPPORT TOOL (CONT)

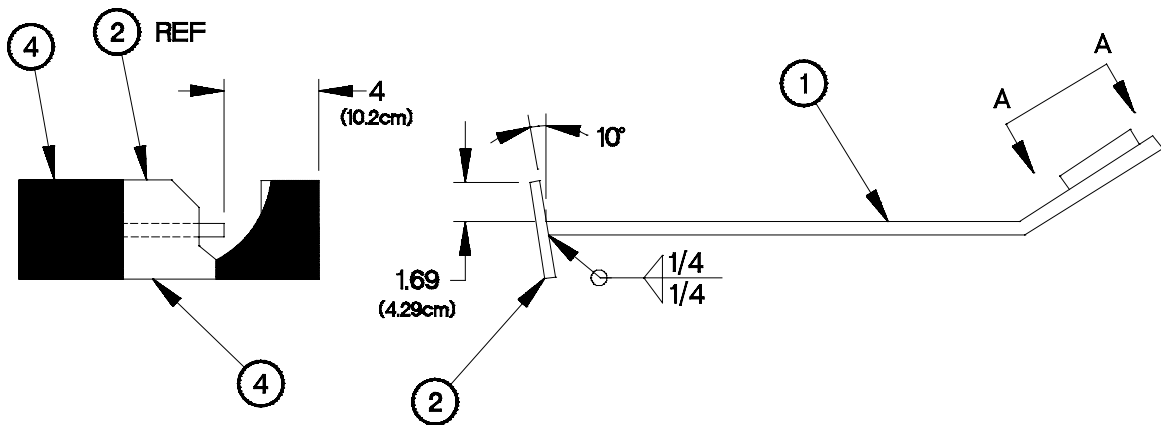

XAPPE061

Figure E-6. Cab Support Tool Assembly

- m. Position and clamp cab support tool strut (1) to cab support tool cab rest (2) as shown by dimensions on **Figure E-6. Cab Support Tool Assembly**, before insulgrip (4) is applied.
- n. Weld cab support tool strut (1) to cab support tool cab rest (2).
- o. Apply Insulgrip (4) to cab support tool cab rest (2) as described on material container.

E-5. DUMP BODY LIFTING BRACKET

Make the dump body lifting bracket assembly from the front, rear, top, guide, and mount plates according to the following instructions. Refer to the parts list tables and accompanying figures for details.

Item	Part Number	Name/Description	Qty
1	N/A	Rear Plate	1
2	N/A	Top Plate	1
3	N/A	Front Plate	1
4	N/A	Guide Brace	1
5	N/A	Plate, Mounting	1

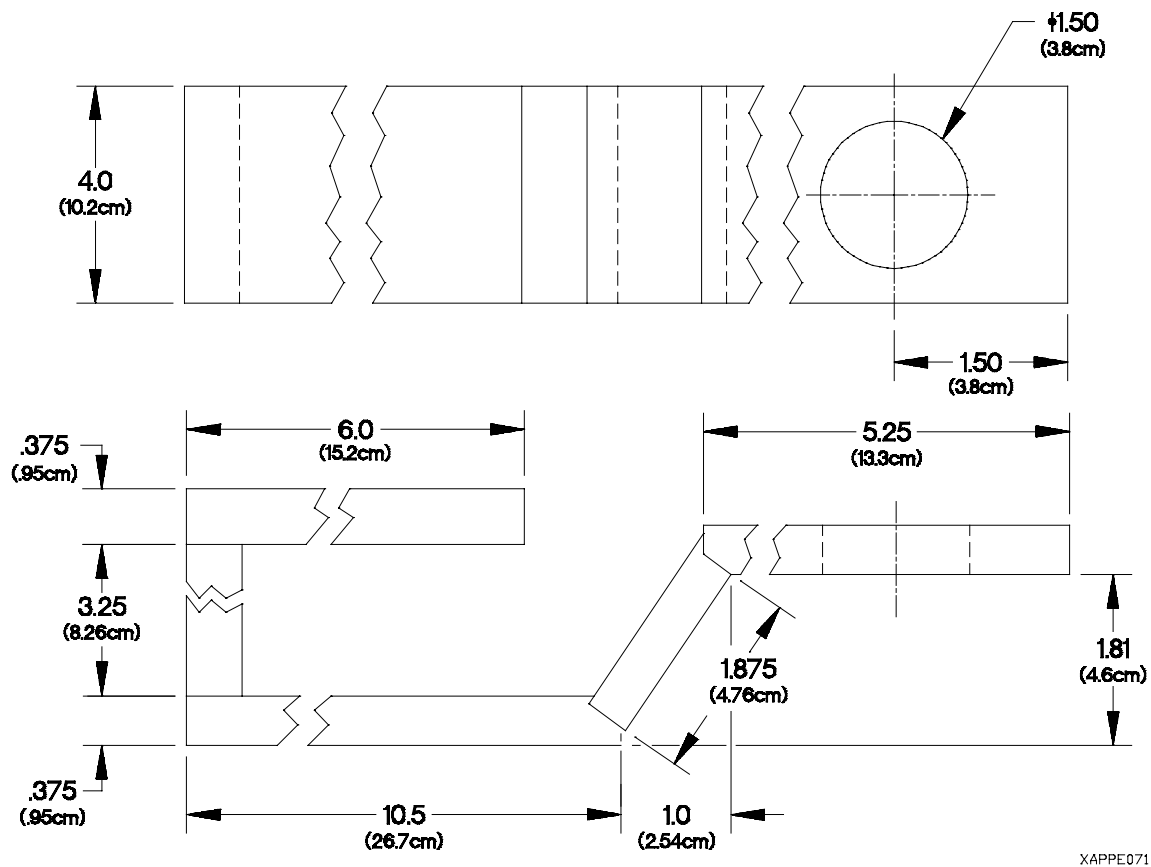
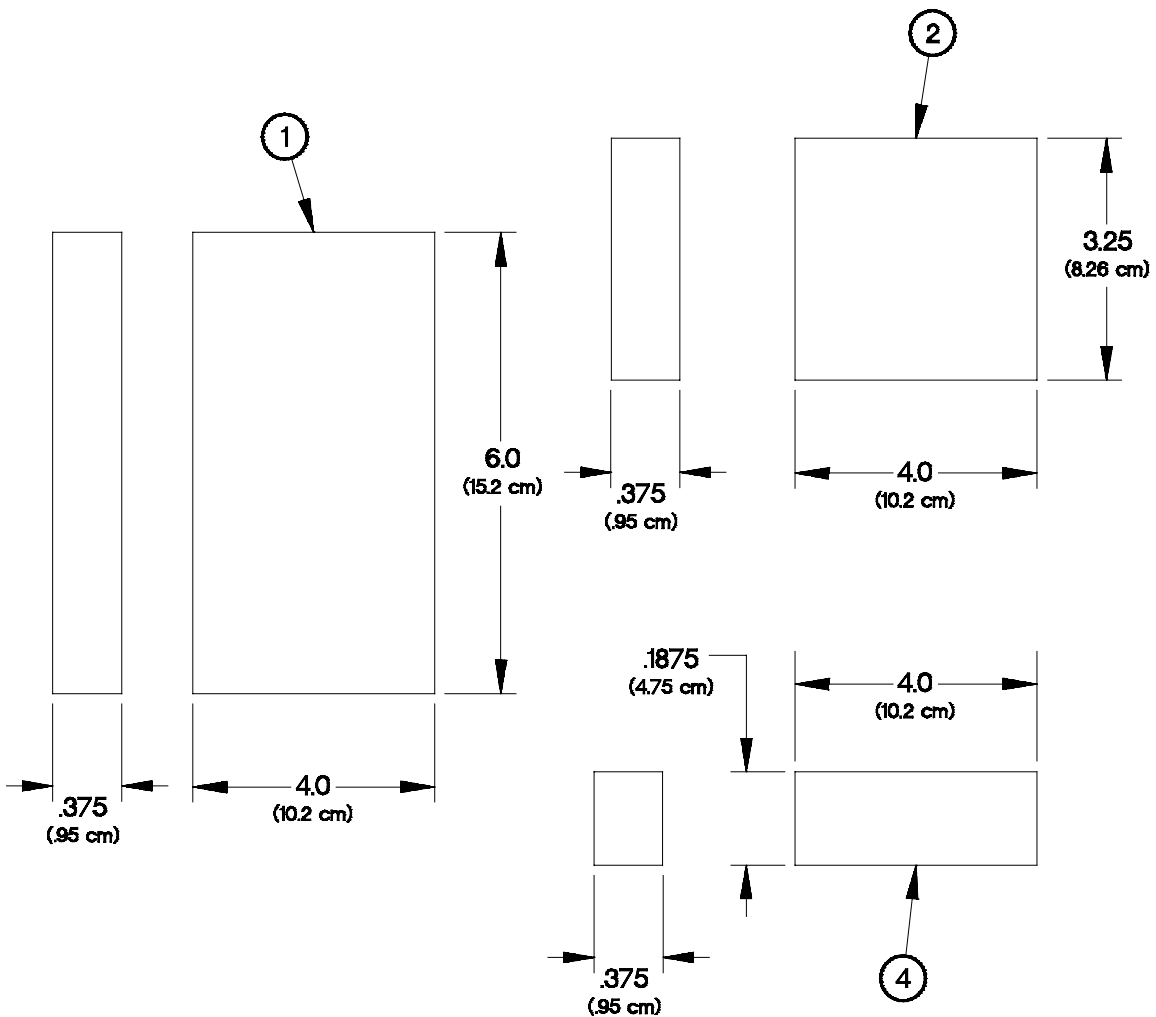

Figure E-7. Dump Body Lifting Bracket

- a. All dimensions are in inches (centimeters).
- b. Position and clamp pieces (1 through 5) together as shown by dimensions on **Figure E-7. Dump Body Lifting Bracket**.
- c. Weld pieces together as shown in **Figure E-7. Dump Body Lifting Bracket**.
- d. Coat all surfaces with Plastisol.

E-5. DUMP BODY LIFTING BRACKET (CONT)

Item	Part Number	Material Description	Size	Qty
1	N/A	Plate, steel, ASTM A-36	6.0 in. (15.2 cm) X 4.0 in. (10.2 cm) X 0.375 in. (0.95 cm)	1
2	N/A	Plate, steel, ASTM A-36	3.25 in. (8.26 cm) X 4.0 in. (10.2 cm) X 0.375 in. (0.95 cm)	1
4	N/A	Plate, steel, ASTM A-36	1.875 in. (4.75 cm) X 4.0 in. (10.2 cm) X 0.375 in. (0.95 cm)	1



XAPPE081

Figure E-8. Rear, Top, and Guide Plate

- a. All dimensions are in inches (centimeters).
- b. Fabricate (1),(2), and (4) from ASTM A-36 steel plate as shown on **Figure E-8. Rear, Top, and Guide Plate**.
- c. De-burr and remove sharp edges.

Item	Part Number	Material Description	Size	Qty
3	N/A	Plate steel, ASTM A36	10.5 in. (26.7 cm) X 4.0 in. (10.2 cm) X 0.375 in. (0.95 cm)	1
5	N/A	Plate steel, ASTM A36	5.25 in. (13.3 cm) X 4.0 in. (10.2 cm) X 0.375 in. (0.95 cm)	1

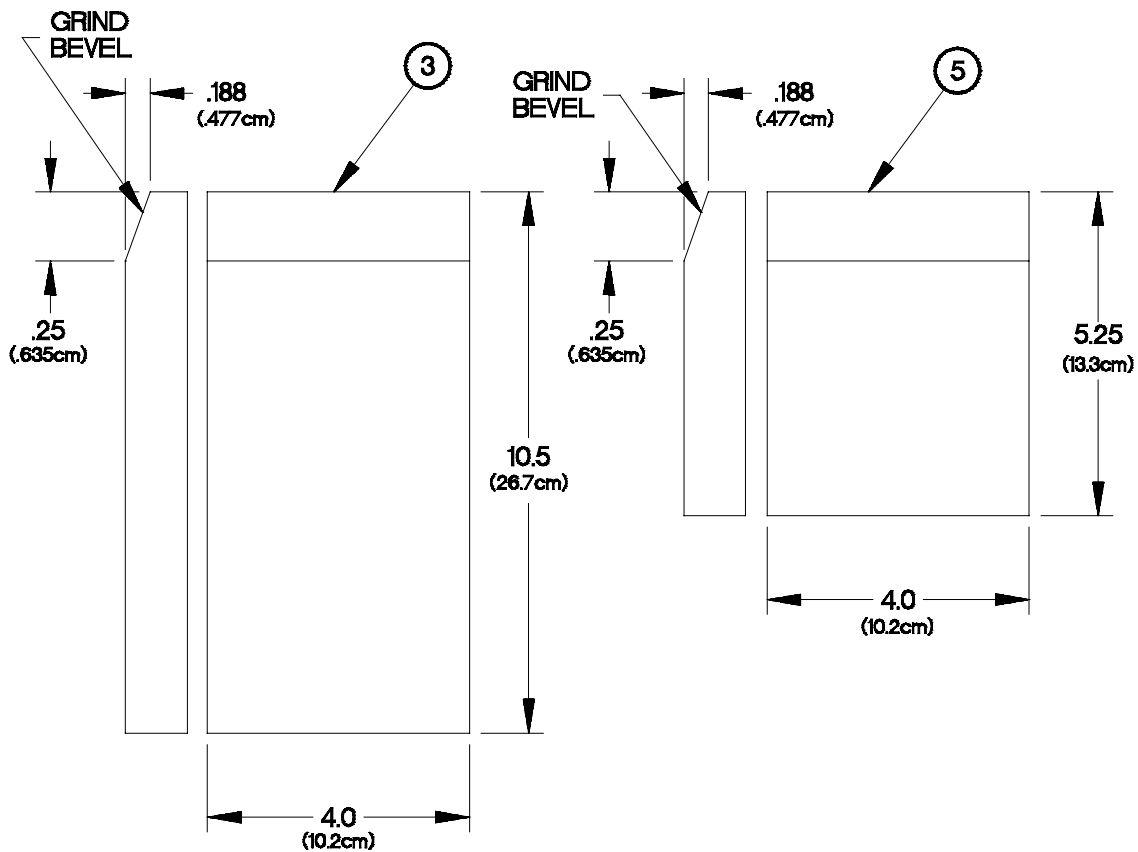

XAPPE091

Figure E-9. Front and Mounting Plate

- All dimensions are in inches (centimeters).
- Fabricate (3) and (5) from ASTM A-36 steel plate.
- Drill 1-1/2 inch (3.84 cm) diameter hole in (5) as shown on **Figure E-9. Front and Mounting Plate.**
- Grind bevel edge of each plate for weld surface as shown on **Figure E-9. Front and Mounting Plate.**
- De-burr and remove sharp edges.

E-6. HEADLIGHT ADJUSTMENT SCREEN

The headlight adjustment screen may be drawn on any vertical surface at least 50 in. (127 cm) high and 100 in. (254 cm) wide.

- a. Draw two vertical lines (1) 50 in. (127 cm) high and 90.6 in. (230 cm) apart (centered on headlight adjustment screen).
- b. Locate two points 40 in. (101.6 cm) from floor and 13 in. (33 cm) toward the center from each vertical line (1).
- c. Draw vertical line (2) about 3-5 in. (8-13 cm) centered on each of the two points.
- d. Draw horizontal line (3) about 3-5 in. (8-13 cm) centered on each of the two points.
- e. Measure out 4 in. (10 cm) along each vertical line (2) and horizontal line (3) from each of the two points to make 8 in. (20 cm) squares (4).

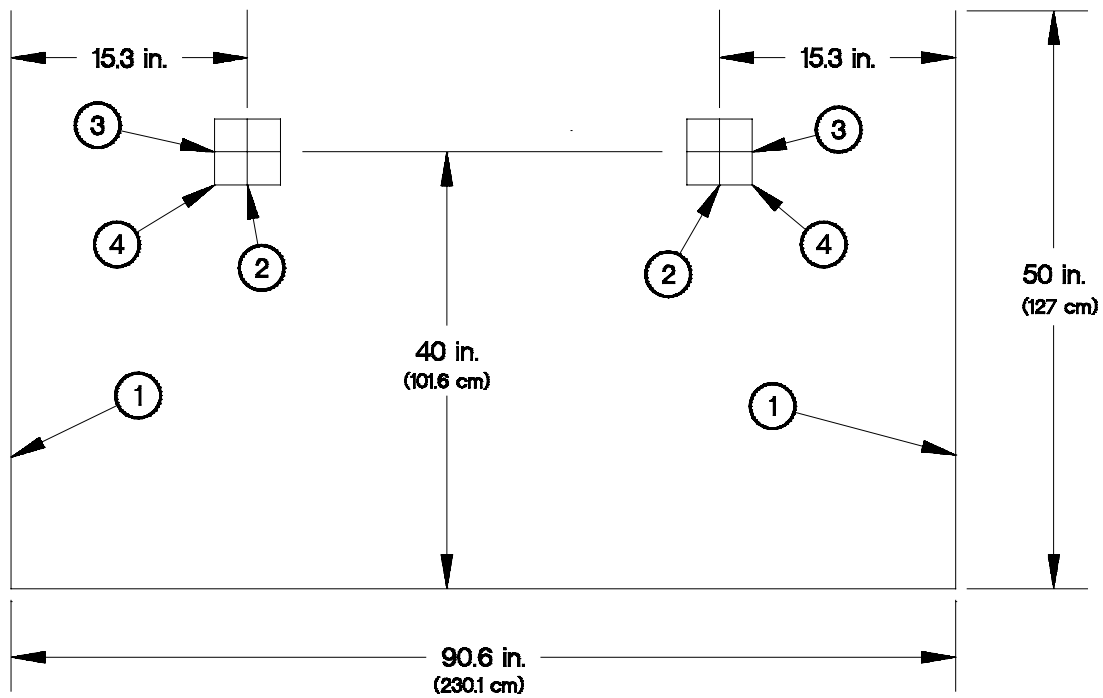

XAPPE101

Figure E-10. Headlight Adjustment Screen

E-7. M1089 30K WINCH TEST ADAPTER

Assemble the M1089 30K winch test adapter according to the following steps. Refer to the following parts list and **Figure E-11. M1089 30K Winch Test Adapter** for details.

Part Number	Material Description	National Stock Number	Qty
4-4-4 100401BA	Tee, Tube	4730-01-095-3430	1
4-6 100102BA	Adapter, Straight, Pipe to Tube	4730-01-096-9398	1
207P-4	Coupling, Pipe	4730-00-881-1161	1
NB-4-035	Tubing, Nonmetallic	4720-01-071-4042	4 in.
MIL-T-27730	Tape, Antiseizing	8030-00-889-3534	1 roll

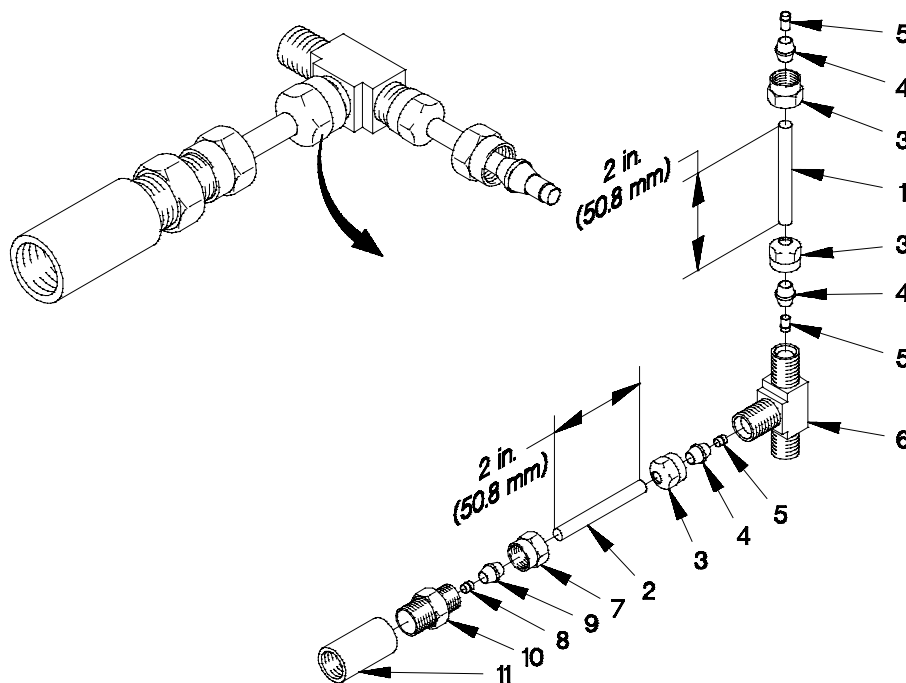

XAPPE111

Figure E-11. M1089 30K Winch Test Adapter

- All dimensions are in inches (millimeters).
- Cut two pieces of nonmetallic tubing (1 and 2) to 2.0 in. (50.8 mm) long.
- Remove three nuts (3), sleeves (4), and ferrules (5) from tube tee (6).
- Install two nuts (3), sleeves (4), and ferrules (5) on nonmetallic tubing (1).
- Install nonmetallic tubing (1) on tube tee (6).
- Remove nut (7), sleeve (8), and ferrule (9) from straight adapter (10).
- Install two nuts (3 and 7), sleeves (4 and 8), and ferrules (5 and 9) on nonmetallic tubing (2).
- Install nonmetallic tubing (2) on tube tee (6).
- Install nut (9) on straight adapter (10).
- Apply one wrap of antiseizing tape to threads of straight adapter (10).
- Install pipe coupling (11) on straight adapter (10).

E-8. M1089 SOLENOID TEST ADAPTER

Assemble the M1089 solenoid test adapter according to the following steps. Refer to the following parts list and **Figure E-12. M1089 Solenoid Test Adapter** for details.

Part Number	Material Description	National Stock Number	Qty
2-2-2 080401CA	Tee, Tube	4730-01-214-6990	1
2-2 080202CA	Elbow, Pipe to Tube	4730-00-845-5345	1
4-2 130140B	Bushing, Pipe	4730-00-828-0171	1
NB-2-031	Tubing, Nonmetallic	4720-01-287-4499	24 in.

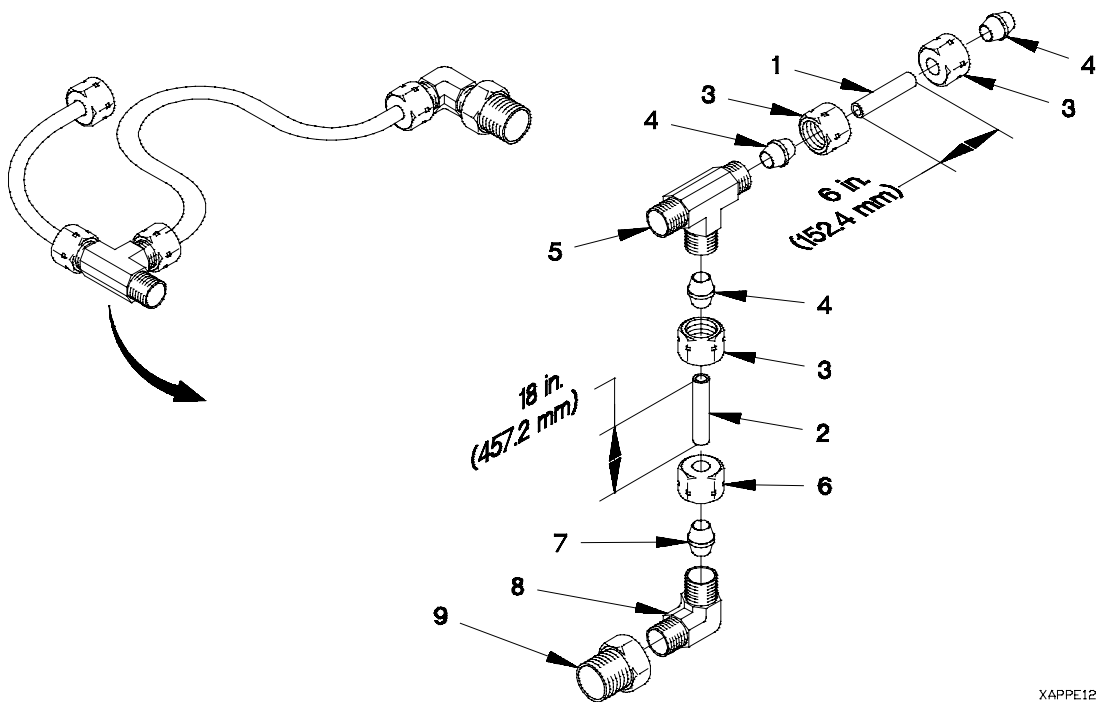

XAPPE121

Figure E-12. M1089 Solenoid Test Adapter

- a. All dimensions are in inches (millimeters).
- b. Cut one piece of nonmetallic tubing (1) to 6.0 in. (152.4 mm) long.
- c. Cut one piece of nonmetallic tubing (2) to 18.0 in. (457.2 mm) long.
- d. Remove three nuts (3) and ferrule sleeves (4) from tube tee (5).
- e. Install two nuts (3) and ferrule sleeves (4) on nonmetallic tubing (1).
- f. Install nonmetallic tubing (1) on tube tee (5).
- g. Remove nut (6) and ferrule sleeve (7) from pipe to tube elbow (8).
- h. Install two nuts (3 and 6) and ferrule sleeves (4 and 7) on nonmetallic tubing (2).
- i. Install nonmetallic tubing (2) on tube tee (5).
- j. Install nut (6) on pipe to tube elbow (8).
- k. Install pipe bushing (9) on pipe to tube elbow (8).

E-9. RELAY TEST WIRE

Fabricate the relay test wire according to the following steps. Refer to the following parts list for materials.

Material Description	National Stock Number	Cut Length
Wire, Electrical (MIL-W-16878)	6145-00-330-3318	6 in. (152 mm)

- a. Dimensions are in inches (millimeters).
- b. Cut a length of wire six inches (152 mm) long.
- c. Remove approximately 3/4 in. (19 mm) of electrical insulation from each end of wire.

E-10. TRANSMISSION AUXILIARY OIL COOLER RUBBER SEAL

Fabricate the transmission auxiliary oil cooler rubber seals in accordance with the following parts list.

Part Number	Description	National Stock Number	Cut Length	
			inches	mm
MIL-R-6130	Tape, Adhesive, Rubber	9320-00-501-7537	24.7	627

E-11. WHEEL BEARING SHIM TOOL REST

Fabricate the wheel bearing shim tool rest according to the following steps. Refer to the following parts list for materials.

Part Number	National Stock Number	Description
QQ-T-570	9510-00-866-1037	Bar, Metal

- a. Dimensions are in inches (millimeters)
- b. Cut metal bar to 9.0 inches (228.6 mm) long.
- c. De-burr and remove sharp edges from ends of metal bar.

E-12. PNEUMATIC TUBES FABRICATION

Cut pneumatic tubes from bulk tubing stock listed in **Table E-1. Pneumatic Tube Lengths**. Use a fine-toothed hacksaw or suitable cutting device and cut tubing to required length.

Table E-1. Pneumatic Tube Lengths

Tube Part Number	Bulk Tubing Part Number	Cut Length	
		inches	cm
12414690-001	NT-100-4 (79470)	18.1	46.0
12414690-002	NT-100-4 (79470)	16.0	40.6
12414690-003	NT-100-4 (79470)	15.0	38.1
12414690-004	NT-100-4 (79470)	74.8	190.0
12414690-005	NT-100-4 (79470)	69.7	177.0

E-12. PNEUMATIC TUBES FABRICATION (CONT)

Table E-1. Pneumatic Tube Lengths (Cont)

Tube Part Number	Bulk Tubing Part Number	Cut Length	
		inches	cm
12414690-006	NT-100-4 (79470)	239.0	607.0
12414690-007	NT-100-4 (79470)	254.8	647.0
12414690-008	NT-100-4 (79470)	286.3	727.0
12414690-009	NT-100-4 (79470)	294.1	747.0
12414690-010	NT-100-4 (79470)	180.0	457.2
12414690-101	J844TYBSIZE 3/8 (81343)	18.0	45.7
12414690-102	J844TYBSIZE 3/8 (81343)	35.4	90.0
12414690-103	J844TYBSIZE 3/8 (81343)	20.9	53.0
12414690-104	J844TYBSIZE 3/8 (81343)	13.8	35.0
12414690-105	J844TYBSIZE 3/8 (81343)	11.8	30.0
12414690-106	J844TYBSIZE 3/8 (81343)	20.5	52.0
12414690-107	J844TYBSIZE 3/8 (81343)	39.0	99.0
12414690-108	J844TYBSIZE 3/8 (81343)	15.4	39.0
12414690-109	J844TYBSIZE 3/8 (81343)	23.0	58.4
12414690-112	J844TYBSIZE 3/8 (81343)	80.0	198.0
12414690-113	J844TYBSIZE 3/8 (81343)	11.4	29.0
12414690-115	J844TYBSIZE 3/8 (81343)	82.8	210.2
12414690-118	J844TYBSIZE 3/8 (81343)	11.8	30.0
12414690-120	J844TYBSIZE 3/8 (81343)	11.9	30.2
12414690-125	J844TYBSIZE 3/8 (81343)	10.8	27.3
12414690-128	J844TYBSIZE 3/8 (81343)	180.1	457.5
12414690-129	J844TYBSIZE 3/8 (81343)	39.3	99.7
12414690-130	J844TYBSIZE 3/8 (81343)	164.4	417.5
12414690-131	J844TYBSIZE 3/8 (81343)	180.1	457.5
12414690-132	J844TYBSIZE 3/8 (81343)	219.5	557.5
12414690-133	J844TYBSIZE 3/8 (81343)		
12414690-134	J844TYBSIZE 3/8 (81343)	277.4	704.5
12414690-135	J844TYBSIZE 3/8 (81343)	325.0	825.5
12414690-136	J844TYBSIZE 3/8 (81343)	332.5	844.6
12414690-137	J844TYBSIZE 3/8 (81343)	51.0	129.5
12414690-138	J844TYBSIZE 3/8 (81343)	67.0	170.2
12414690-139	J844TYBSIZE 3/8 (81343)	98.5	250.2
12414690-140	J844TYBSIZE 3/8 (81343)	106.0	269.2
12414690-141	J844TYBSIZE 3/8 (81343)	52.5	133.4
12414690-142	J844TYBSIZE 3/8 (81343)	68.5	174.0
12414690-143	J844TYBSIZE 3/8 (81343)	100.0	254.0
12414690-144	J844TYBSIZE 3/8 (81343)	107.5	273.0

Table E-1. Pneumatic Tube Lengths (Cont)

Tube Part Number	Bulk Tubing Part Number	Cut Length	
		inches	cm
12414690-145	J844TYBSIZE 3/8 (81343)		
12414690-146	J844TYBSIZE 3/8 (81343)	267.3	679.0
12414690-147	J844TYBSIZE 3/8 (81343)	283.1	719.0
12414690-148	J844TYBSIZE 3/8 (81343)	314.6	799.0
12414690-149	J844TYBSIZE 3/8 (81343)	322.4	819.0
12414690-150	J844TYBSIZE 3/8 (81343)	296.1	752.0
12414690-151	J844TYBSIZE 3/8 (81343)	343.5	872.5
12414690-152	J844TYBSIZE 3/8 (81343)	36.0	91.5
12414690-153	J844TYBSIZE 3/8 (81343)	32.0	81.3
12414690-154	J844TYBSIZE 3/8 (81343)	48.0	122.0
12414690-155	J844TYBSIZE 3/8 (81343)	79.5	202.0
12414690-156	J844TYBSIZE 3/8 (81343)	87.0	221.0
12414690-157	J844TYBSIZE 3/8 (81343)	59.5	151.1
12414690-158	J844TYBSIZE 3/8 (81343)	66.5	169.0
12414690-159	J844TYBSIZE 3/8 (81343)	98.0	249.0
12414690-160	J844TYBSIZE 3/8 (81343)	105.5	268.0
12414690-161	J844TYBSIZE 3/8 (81343)	48.0	122.0
12414690-162	J844TYBSIZE 3/8 (81343)	36.0	91.5
12414690-163	J844TYBSIZE 3/8 (81343)	161.5	410.2
12414690-164	J844TYBSIZE 3/8 (81343)	120.0	304.8
12414690-165	J844TYBSIZE 3/8 (81343)	78.0	198.1
12414690-166	J844TYBSIZE 3/8 (81343)	108.0	274.3
12414690-167	J844TYBSIZE 3/8 (81343)	168.0	426.7
12414690-168	J844TYBSIZE 3/8 (81343)	108.0	274.3
12414690-169	J844TYBSIZE 3/8 (81343)	72.0	182.9
12414690-201	C608-100BLK (13174)	14.8	37.5
12414690-202	C608-100BLK (13174)	14.1	35.7
12414690-203	C608-100BLK (13174)	6.5	16.5
12414690-205	C608-100BLK (13174)	14.5	36.8
12414690-206	C608-100BLK (13174)	14.8	37.7
12414690-207	C608-100BLK (13174)	15.6	39.5
12414690-208	C608-100BLK (13174)	6.7	17.0
12414690-209	C608-100BLK (13174)	19.5	49.5
12414690-210	C608-100BLK (13174)	15.5	39.3
12414690-211	C608-100BLK (13174)	8.0	20.3
12414690-212	C608-100BLK (13174)	17.0	43.0
12414690-215	C608-100BLK (13174)	163.0	414.0
12414690-216	C608-100BLK (13174)	160.0	406.4
12414690-217	C608-100BLK (13174)	62.6	159.0

E-12. PNEUMATIC TUBES FABRICATION (CONT)

Table E-1. Pneumatic Tube Lengths (Cont)

Tube Part Number	Bulk Tubing Part Number	Cut Length	
		inches	cm
12414690-218	C608-100BLK (13174)	119.8	304.2
12414690-219	C608-100BLK (13174)	69.0	175.3
12414690-220	C608-100BLK (13174)	45.5	115.6
12414690-221	C608-100BLK (13174)	12.6	32.0
12414690-222	C608-100BLK (13174)	5.5	14.0
12414690-223	C608-100BLK (13174)	14.6	37.1
12414690-224	C608-100BLK (13174)	170.0	431.8
12414690-225	C608-100BLK (13174)	174.0	442.0
12414690-228	C608-100BLK (13174)	3.5	8.9
12414690-229	C608-100BLK (13174)	62.2	158.1
12414690-230	C608-100BLK (13174)	14.6	37.0
12414690-231	C608-100BLK (13174)	60.5	153.7
12414690-232	C608-100BLK (13174)	126.4	321.0
12414690-233	C608-100BLK (13174)	142.1	361.0
12414690-234	C608-100BLK (13174)		
12414690-235	C608-100BLK (13174)		
12414690-236	C608-100BLK (13174)	131.9	335.0
12414690-237	C608-100BLK (13174)	147.6	375.0
12414690-238	C608-100BLK (13174)	179.5	456.0
12414690-239	C608-100BLK (13174)	187.0	475.0
12414690-240	C608-100BLK (13174)	111.5	283.2
12414690-241	C608-100BLK (13174)	127.5	324.0
12414690-242	C608-100BLK (13174)	159.0	404.0
12414690-243	C608-100BLK (13174)	166.5	423.0
12414690-244	C608-100BLK (13174)	41.0	104.2
12414690-245	C608-100BLK (13174)	57.0	144.8
12414690-246	C608-100BLK (13174)	88.6	225.0
12414690-247	C608-100BLK (13174)	96.0	244.0
12414690-248	C608-100BLK (13174)	48.0	122.0
12414690-249	C608-100BLK (13174)	54.0	137.2
12414690-301	PFT-10B-BLK-100 (61424)	19.0	48.3
12414690-302	PFT-10B-BLK-100 (61424)	56.0	142.2
12414690-303	PFT-10B-BLK-100 (61424)	118.1	300.0

E-13. NON-METALLIC ELECTRICAL CABLE CONDUIT FABRICATION
--

Make conduit to cover electrical cables described on 1241638 from bulk tube stock listed in **Table E-2. Non-Metallic Electrical Cable Conduit Lengths**. Use a fine-toothed hacksaw or suitable cutting device and cut hose/tube to required length.

Table E-2. Non-Metallic Electrical Cable Conduit Lengths

Tube Part Number	Bulk Tube Part Number	Cut Length	
		inch	cm
12416381P1	49008	8.9	22.6
12416381P10	49008	17.8	45.2
12416381P11	49008	29.9	75.9
12416381P12	49008	33.0	83.8
12416381P13	49008	13.9	35.3
12416381P14	49008	4.0	10.2
12416381P15	49008	17.4	44.2
12416381P16	49008	3.2	8.1
12416381P17	49008	4.5	11.4
12416381P2	49008	16.2	41.1
12416381P20	27413	32.8	83.3
12416381P21	27413	9.2	23.4
12416381P22	27413	8.0	20.3
12416381P23	27413	23.3	59.2
12416381P26	49008	2.5	6.4
12416381P3	27413	7.3	18.5
12416381P30	49007	17.0	43.2
12416381P32	49005	1.7	4.3
12416381P34	49005	20.7	52.6
12416381P35	49005	21.8	55.4
12416381P36	49005	5.5	14.0
12416381P37	49005	8.0	20.3
12416381P38	49008	3.7	9.4
12416381P4	49008	12.0	30.5
12416381P5	49008	26.0	66.0
12416381P6	49008	7.7	19.6
12416381P7	49008	26.7	67.8
12416381P8	49008	5.2	13.2
12416381P9	49008	16.8	42.7

E-14. STEERING GEAR RETURN HOSE AND TRANSMISSION OIL COOLER HOSES FABRICATION

Cut the following hoses from bulk hose using a fine-toothed hacksaw or suitable cutting device.

Hose Part Number	Bulk Hose Part Number	Cut Length	
		inches	cm
12418037	A110 (30327)	75.5	191.7
12418460-001	MS521302B110360 (96906)	17.5	44.4
12418460-002	MS521301A206R (96906)	16.0	40.6

E-15. LANYARD ASSEMBLIES P/N 12418763 AND 12420196 FABRICATION

Make the following lanyard assemblies from bulk cable material, sleeves, and tab material and assemble according to **Figure E-14. Lanyard Assembly**. The following parts list identifies part numbers and lengths of cut pieces.

Item	Part Number	Material Description	Size	Qty
1	MIL-W-83420 Type 1, Comp B	1/16 in. stranded wire cable	4 in. (102 mm)	1
2	MS51844-22	Sleeve		2
3	N/A	Tab, Stainless Steel ASTM A617	.06 in. (16 cm) X .37 in. (9.5 mm) X 1.25 in. (32 mm)	1

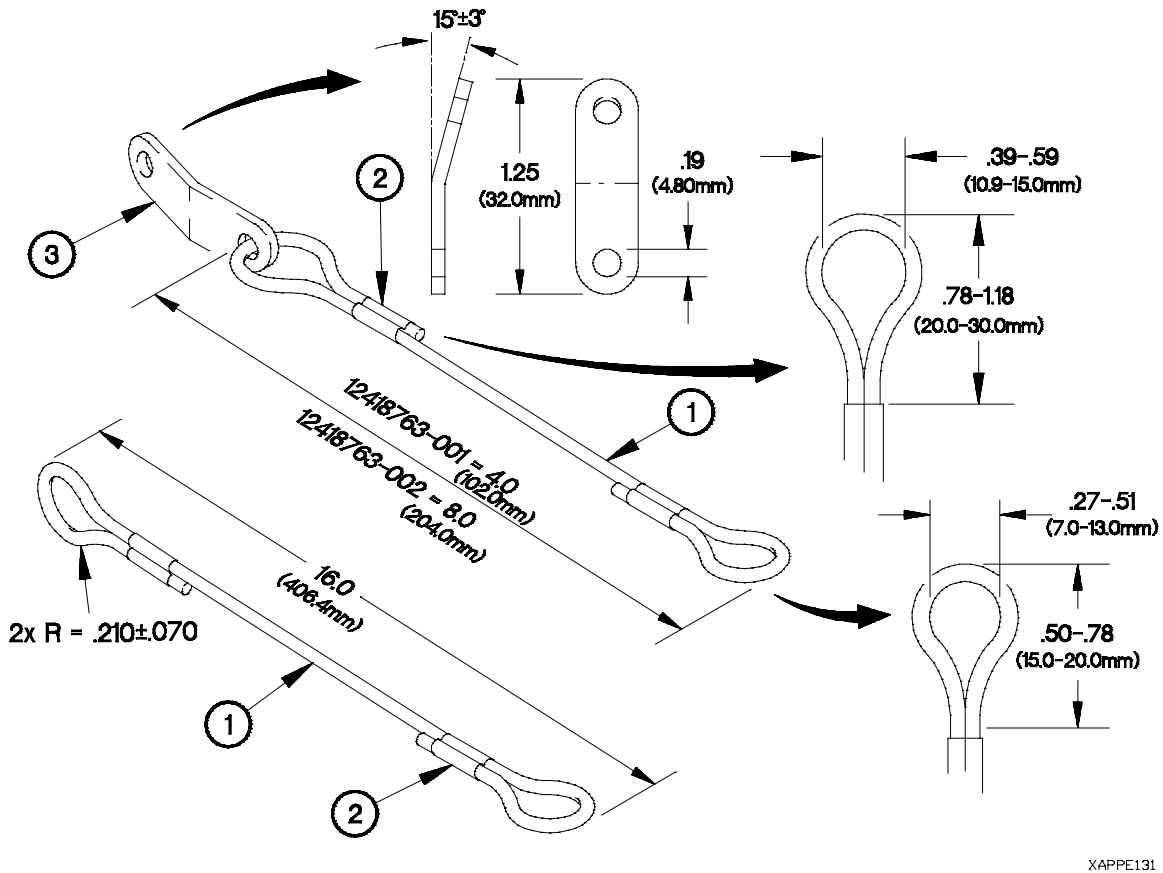

XAPPE131

Figure E-14. Lanyard Assembly

- a. All dimensions are in inches (millimeters).
- b. Make from bulk cable and flat steel material as identified in parts list.
- c. Drill two 0.19 in. (4.8 mm) diameter holes through tab material as shown on **Figure E-14. Lanyard Assembly.**
- d. De-burr and remove sharp edges.
- e. Bend tab as shown on **Figure E-14. Lanyard Assembly.**
- f. Form loops on cable ends and insert sleeve material over cable on one end of cable and over cable and through sleeve at other end of cable as shown in **Figure E-14. Lanyard Assembly.**
- g. Crimp two sleeves over cable ends.

E-16. NON-METALLIC VENT AIR HOSES FABRICATION

Cut the following vent air hoses from bulk hose using a fine-toothed hacksaw or suitable cutting device.

Hose Part Number	Bulk Hose Part Number	Cut Length	
		inches	cm
12420197-001	483666 (02280)	180.0	457.2
12420197-002	483666 (02280)	120.0	304.8
12420197-003	483666 (02280)	96.0	243.8
12420197-004	483666 (02280)	36.0	91.4
12420197-005	483666 (02280)	156.0	396.2
12420197-006	483666 (02280)	72.0	182.9
12420198-001	881-16 (98441)	120.0	304.8
12420198-002	11657469	36.0	91.4

E-17. PERSONNEL HEATER AIR DUCT HOSE FABRICATION

Cut the following hoses from bulk hose using a fine-toothed hacksaw or suitable cutting device.

Hose Part Number	Bulk Hose Part Number	Cut Length	
		inches	cm
12420308-457	8711054 (19207)	18.3	46.4
12420308-760	8711054 (19207)	30.4	77.2

E-18. BLOCK SEAL 12420489 FABRICATION

Make block seal from P/N (0VXY8) STN2.38X.5. Use a suitable cutting tool to cut seal to 0.52 inch (1.3 cm) long.

E-19. CTIS SEAL DRIVER 3256-H-1048

Used on Front, Intermediate, and Rear Axle CTIS Seals.

NOTES ON USE OF DRIVER

- 1) SEAL END OF DRIVER TO BE CLEAN OF DEBRIS, DIRT, NICKS AND BURRS
- 2) DO NOT USE A METAL HAMMER ON DRIVER
A RUBBER, PLASTIC, WOOD OR SOME OTHER DEAD BLOW TYPE MALLET IS TO BE USED
- 3) SLIGHTLY GREASE SEAL END OF DRIVER PRIOR TO INSTALLING SEAL

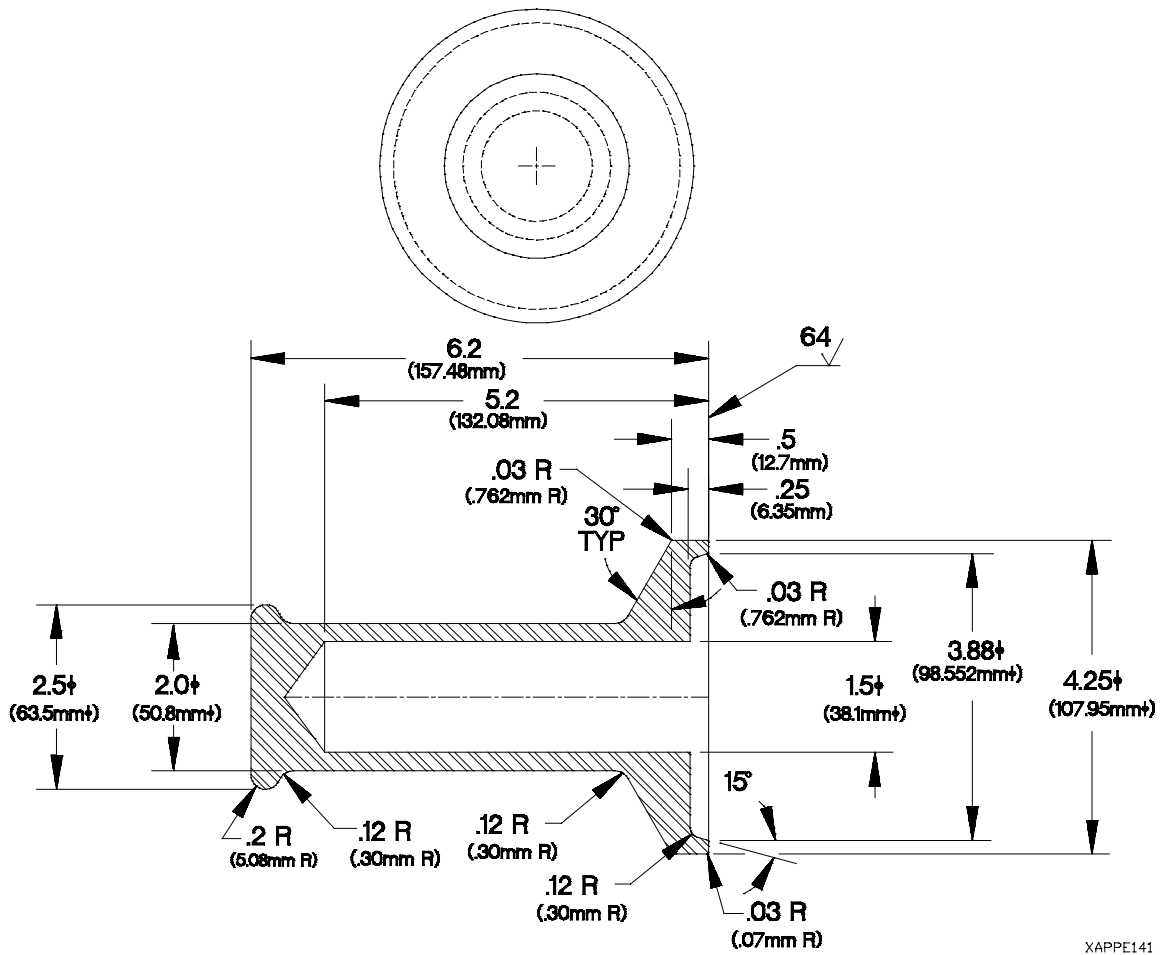

Figure E-15. CTIS Seal Driver

- a. All dimensions are in inches (millimeters).
- b. Manufacture from round steel stock.
- c. De-burr and remove sharp edges.

E-20. WHEEL HUB GREASE SEAL DRIVER 3256-K-1051

NOTES ON USE OF DRIVER

- 1) SEAL END OF DRIVER TO BE CLEAN OF DEBRIS, DIRT, NICKS AND BURRS
- 2) DO NOT USE A METAL HAMMER ON DRIVER
A RUBBER, PLASTIC, WOOD OR SOME OTHER DEAD BLOW TYPE Mallet IS TO BE USED
- 3) SLIGHTLY GREASE SEAL END OF DRIVER PRIOR TO INSTALLING SEAL

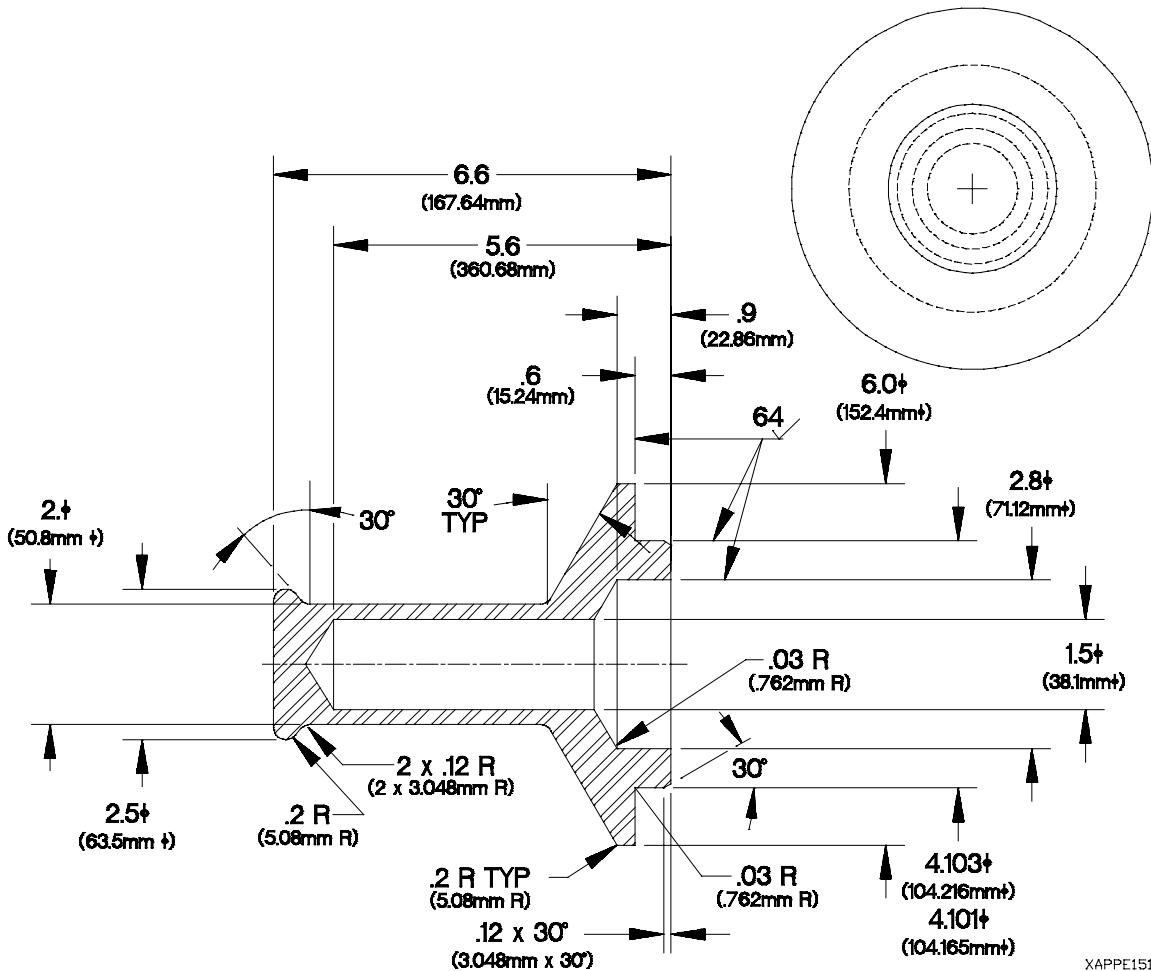

Figure E-16. Wheel Hub Grease Seal Driver

- a. All dimensions are in inches (millimeters).
- b. Manufacture from round steel stock.
- c. De-burr and remove sharp edges.

E-21. DIMMER SWITCH TEST WIRE

Fabricate the dimmer switch test wire according to the following steps. Refer to the following parts list for materials.

Material Description	National Stock Number	Quantity	Cut Length
Wire, Electrical (M168678/14BKE9)	6145-01-229-4134	1	12 in (305 mm)
Pin, Grooved, Headless (12258939-1)	5315-01-156-6314	1	
Contact, Electrical (12258939-2)	5999-01-150-8808	1	

- a. Dimensions are in inches (millimeters).
- b. Cut a length of electrical wire approximately 12 in. (305 mm) long.
- c. Remove approximately 1/4 in. (6 mm) of insulation from each end of electrical wire.
- d. Crimp headless grooved pin on one end of electrical wire.
- e. Crimp electrical contact on opposite end of electrical wire.

E-22. PURGE VALVE TOOL

Fabricate Purge Valve Tool according to the following instructions. Refer to Figure E-17. Purge Valve Tool for details.

Item	Part Number	Material Description	Size	Qty
1	N/A	Steel, ASTM A 108 or A576 Grade 1015-1025, BAR (Ref UNS G10150-G10250). Finish Black Oxide Coat, Class I, IAW MIL-C-13924.	14.0 in. (356 mm)	1

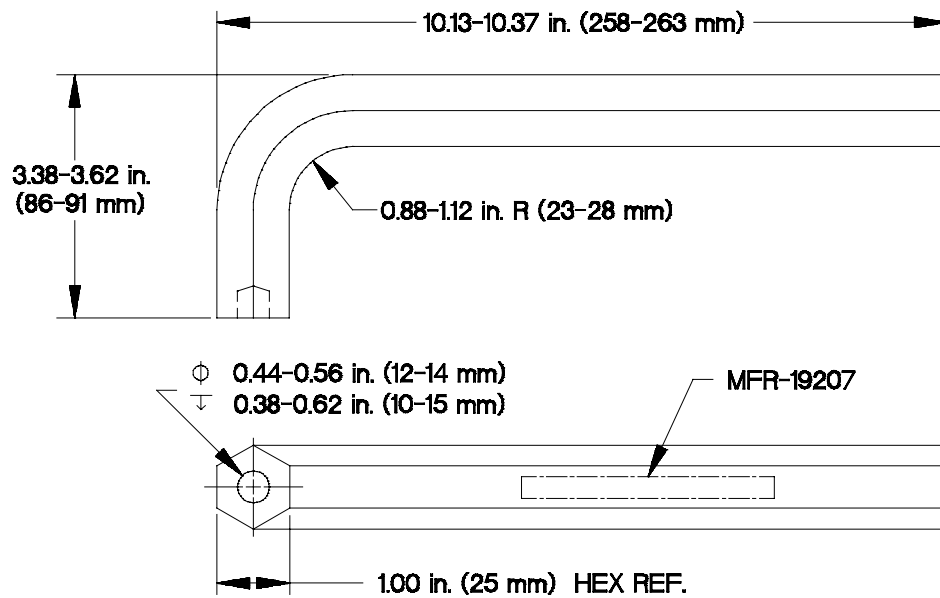

Xappe17b

Figure E-17. Purge Valve Tool

- All dimensions are in inches (cm).
- Cut steel bar (1) and bend to shape as shown in Figure E-17.
- Dimensional limits apply after coating.
- All edges shall be broken and free from burrs.
- Metal Stamp, electro etch, or engrave with the following marking IAW MIL-STD-130: 19207-12379968 MFR-19207.

E-23. M1089 30K WINCH AIR HOSES

Cut air hoses and convoluted tubing from bulk hose stock listed in Table E-3. M1089 30K Winch Air Hose Lengths and Fittings. Use a fine-toothed hacksaw or suitable cutting device and cut air hoses and convoluted tubing to required length.

Table E-3. M1089 30K Air Hose Lengths and Fittings

Hose Name	Bulk Hose P/N	Hose Cut Length		Bulk Convoluted Tubing P/N	Convoluted Tubing Cut Length		Fittings P/N	Fittings Qty.
		in.	mm		in.	mm		
Air Supply	NB-4-035	96.0	2438	12420924-001	94.0	2388	4-100110B 4-100115B 63NTA-4	2 2 2
Manifold Supply	NB-4-035	40.0	1016	12420924-001	38.0	965	4-100110B 4-100115B 63NTA-4	2 2 2
LH freespool	NB-4-035	66.0	1676	12420924-001	64.0	1626	4-100110B 4-100115B 63NTA-4	2 2 2
RH freespool	NB-4-035	48.0	1219	12420924-001	46.0	1168	4-100110B 4-100115B 63NTA-4	2 2 2
LH regulator input	NB-4-035	12.0	305	N/A	N/A	N/A	4-100110B 4-100115B 63NTA-4	2 2 2
RH regulator input	NB-4-035	12.0	305	N/A	N/A	N/A	4-100110B 4-100115B 63NTA-4	2 2 2
LH check valve return	NB-4-035	3.0	76	N/A	N/A	N/A	4-100110B 4-100115B 63NTA-4	2 2 2
RH check valve return	NB-4-035	3.0	76	N/A	N/A	N/A	4-100110B 4-100115B 63NTA-4	2 2 2
Front LH tension supply	NB-4-035	48.0	1219	12420924-001	46.0	1168	4-100110B 4-100115B 63NTA-4	2 2 2
Front RH tension supply	NB-4-035	66.0	1676	12420924-001	64.0	1626	4-100110B 4-100115B 63NTA-4	2 2 2

Table E-3. M1089 30K Air Hose Lengths and Fittings (Cont)

Hose Name	Bulk Hose P/N	Hose Cut Length		Bulk Convoluted Tubing P/N	Convoluted Tubing Cut Length		Fittings P/N	Fittings Qty.
		in.	mm		in.	mm		
RH 30K winch supply	NB-2-016	40.0	1016	N/A	N/A	N/A	2-2 100102BA 2-2 100202BA	1 1
RH 30K winch return	NB-2-016	40.0	1016	N/A	N/A	N/A	2-2 100102BA	2
Underlift fold supply	NB-2-016	40.0	1016	N/A	N/A	N/A	2-2 100102BA	1
Underlift fold return	NB-2-016	40.0	1016	N/A	N/A	N/A	2-2 100102BA 2-2 100202BA	1 1
Underlift supply	NB-2-016	40.0	1016	N/A	N/A	N/A	2-2 100102BA	2
Underlift return	NB-2-016	40.0	1016	N/A	N/A	N/A	2-2 100102BA 2-2 100202BA	1 1
Stinger supply	NB-2-016	40.0	1016	N/A	N/A	N/A	2-2 100102BA	2
Stinger Return	NB-2-016	40.0	1016	N/A	N/A	N/A	2-2 100102BA 2-2 100202BA	1 1
LH 30K Winch supply	NB-2-016	40.0	1016	N/A	N/A	N/A	2-2 100102BA 2-2 100202BA	1 1
LH 30K winch return	NB-2-016	40.0	1016	N/A	N/A	N/A	2-2 100102BA	2

E-24. M1089 30K WINCH PNEUMATIC TEST ADAPTER

Assembly the M1089 30K winch pneumatic test adapter to the following steps. Refer to the following parts list and **Figure E-18. M1089 30K Winch Pneumatic Test Adapter** for details.

Part Number	Material Description	National Stock Number	Qty.
NB-4-035	Tubing, Nonmetallic	4720-01-071-4042	14 in. (355.6 mm)
MIL-T-27730	Tape, antiseizing	8030-00-889-3534	1 roll
207P-4	Coupling, Pipe	4730-00-881-1161	1
4-6 100102 BA	Adapter, Straight, Pipe to Tube	4730-01-096-9398	1
4-4 100101 BA	Nipple, Tube	4730-01-091-4012	1

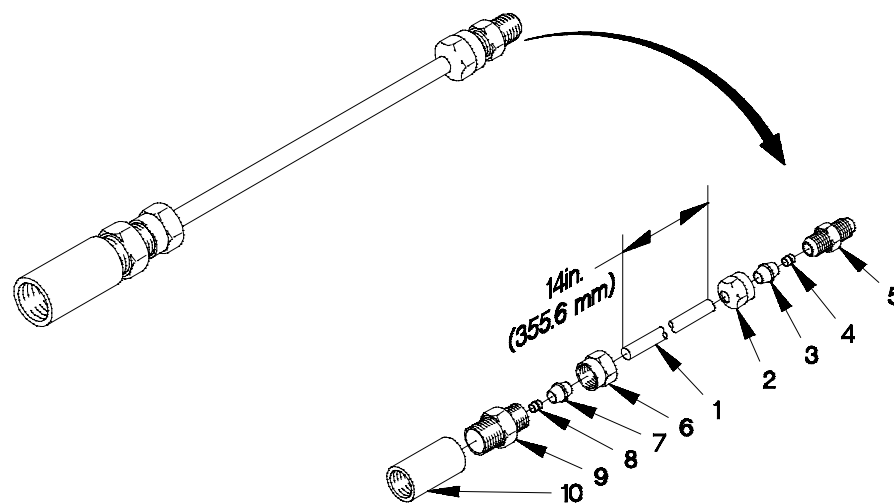

Xappe18b

Figure E-18. M1089 30K Winch Pneumatic Test Adapter

- a. All dimensions are in inches (millimeter).
- b. Cut piece of nonmetallic tubing (1) to 14.0 in. (355.6 mm).
- c. Remove two nuts (2), ferrules (3), and sleeves (4) from tube nipple (5).
- d. Install nut (2), ferrule (3), and sleeve (4) on nonmetallic tubing (1).
- e. Install nonmetallic tubing (1) on tube nipple (5).
- f. Remove nut (6), ferrule (7), and sleeve (8) from straight adapter (9).
- g. Install nut (6), ferrule (7), and sleeve (8) on nonmetallic tubing (1).
- h. Install nonmetallic tubing (1) on straight adapter (9).
- i. Apply on wrap of antiseizing tape to threads of straight adapter (9).
- j. Install pipe coupling (10) on straight adapter (9).
- k. Retain nut (2), ferrule (3), and sleeve (4) for future use.

APPENDIX F TORQUE LIMITS

F-1. GENERAL

This appendix provides general torque limits for screws and nuts used on the vehicle. Special torque limits are shown in the maintenance procedures for applicable components. Use the general torque limit given in this appendix when specific torque limits are not given in the maintenance procedure. These general torque limits can not be applied to screws that retain rubber components. The rubber components will be damaged before the torque limit is reached. If a special torque limit is not given in the maintenance instructions for a fastener which retains a rubber component, tighten the screw or nut until it touches metal, then tighten one more turn. Whenever possible, the tightening force (torque) should be applied to the nut side of the fastener group.

F-2. TORQUE LIMITS

Refer to **Table F-1. Torque Limits for SAE and ANSI Fasteners** for torque limits on standard (SAE and ANSI) screws and free spinning nuts. Refer to **Table F-2. Torque Limits for SAE and ANSI Prevailing Torque Nuts** for torque limits on standard (SAE and ANSI) self-locking nuts. Refer to **Table F-3. Torque Limits for Metric Screws and Free Spinning Nuts** for torque limits on metric screws and free spinning nuts. Refer to **Table F-4. Torque Limits for Metric Prevailing Torque Nuts** for torque limits on metric self-locking nuts.

F-3. USE OF TORQUE TABLES

- (1) Measure the diameter of the screw to be installed.
- (2) Count the number of threads per inch.
- (3) Under the heading DIAMETER look down the column until the diameter of the screw is found. (There are usually two lines beginning with the same diameter.)
- (4) Under the heading THREADS PER INCH (SAE and ANSI) or THREAD PITCH (metric), find the number of threads per inch that matches the number counted in step (2).
- (5) To find the grade of the screw, match the markings on the head to the correct picture under CAPSCREW HEAD MARKINGS on the torque table.
- (6) Look down the column under the picture found in step (5) until the torque limit (lb-ft or N·m) for the diameter and threads per inch (or thread pitch, in the case of metric fasteners) of the screw are located.

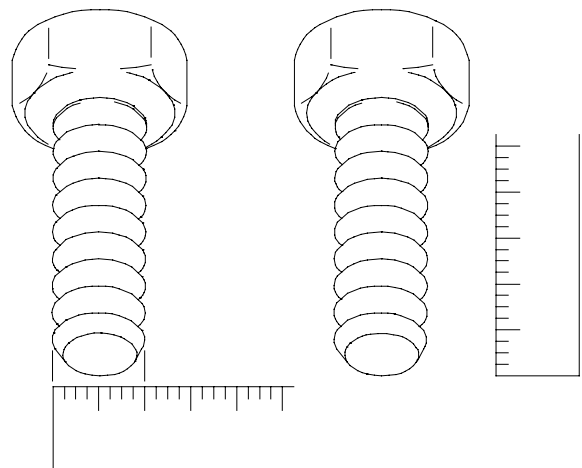

XAPPF01A

APPENDIX F TORQUE LIMITS

Table F-1. Dry Torque Limits for SAE and ANSI Screws and Free Spinning Nuts

 <p style="text-align: center; margin-top: 5px;">NOTE Manufacturer's marks may vary. These are all SAE Grade 5.</p>		Material Grade Markings					
		 <p style="text-align: center; margin-top: 5px;">XAPPF03A SAE Grade 2</p>		 <p style="text-align: center; margin-top: 5px;">XAPPF04A SAE Grade 5</p>		 <p style="text-align: center; margin-top: 5px;">XAPPF051 SAE Grade 8</p>	
		Torque					
Diameter	Threads per inch						
inch		lb-ft	N-m	lb-ft	N-m	lb-ft	N-m
1/4	20	3-5	5-7	5-7	8-10	8-10	10-14
1/4	28	4-6	5-7	6-8	9-11	8-12	12-16
1/4	32	4-6	5-7	7-9	9-11	9-13	12-16
5/16	18	7-9	9-13	11-15	15-21	15-21	21-29
5/16	24	8-10	11-15	12-16	17-23	17-23	24-32
5/16	32	9-11	12-16	14-18	18-24	19-25	27-34
3/8	16	13-17	17-23	20-26	27-35	28-38	38-50
3/8	24	15-19	20-26	22-30	31-41	32-42	43-57
3/8	32	15-21	21-27	24-32	33-43	33-45	55-61
7/16	14	20-28	28-38	32-42	43-57	44-60	61-81
7/16	20	23-31	31-41	35-47	48-64	49-67	68-90
7/16	28	25-33	33-45	37-51	51-69	54-72	73-97
1/2	13	32-42	43-57	49-65	66-88	68-92	93-123
1/2	20	35-47	48-64	55-73	74-98	77-103	105-139
1/2	28	38-50	51-67	58-78	79-105	82-110	111-149
9/16	12	55-61	62-82	70-94	95-127	98-132	134-178
9/16	18	50-68	69-91	78-104	105-141	109-147	149-199
9/16	24	53-71	72-96	82-110	111-149	115-155	158-210
5/8	11	62-84	85-113	95-129	131-175	136-182	184-246
5/8	18	70-94	96-128	108-146	148-198	154-206	209-279
5/8	24	73-99	100-134	114-154	155-207	161-217	219-293

Table F-1. Dry Torque Limits for SAE and ANSI Screws and Free Spinning Nuts (Cont)

 Manufacturer's marks may vary. These are all SAE Grade 5		Material Grade Markings					
		 SAE Grade 2	 SAE Grade 5	 SAE Grade 8	Torque		
Diameter	Threads per inch	lb-ft	N-m	lb-ft	N-m	lb-ft	N-m
inch							
11/16	24	99-133	135-181	153-207	209-279	217-291	296-394
3/4	10	110-148	150-200	171-229	232-310	240-324	328-438
3/4	16	123-165	168-224	190-256	259-345	269-361	366-488
3/4	20	127-171	174-232	197-265	268-358	278-374	379-505
13/16	20			252-340	345-459	357-481	487-649
7/8	9			275-369	374-498	387-521	528-704
7/8	14			303-407	413-551	427-575	583-777
7/8	20			319-429	435-579	450-606	614-818
15/16	20			395-531	538-718	558-750	760-1014
1	8			411-553	560-748	581-781	792-1056
1	12			450-606	614-818	636-856	867-1155
1	20			483-649	658-878	681-917	929-1239
1-1/16	18			576-776	782-1044	813-1095	1109-1479
1-1/8	7			507-683	693-923	824-1108	1123-1497
1-1/8	12			570-766	776-1034	923-1241	1258-1678
1-1/8	18			600-806	817-1089	971-1307	1324-1766
1-3/16	18			709-953	966-1288	1149-1545	1566-2088
1-1/4	7			716-964	976-1302	1161-1563	1584-2112
1-1/4	12			793-1067	1081-1441	1286-1730	1754-2338
1-1/4	18			831-1117	1132-1510	1346-1812	1835-2447
1-5/16	18			965-1299	1316-1754	1565-2105	2134-2846
1-3/8	6			939-1263	1281-1707	1523-2049	2076-2768

APPENDIX F TORQUE LIMITS

Table F-2. Dry Torque Limits for SAE and ANSI Prevailing Torque Nuts

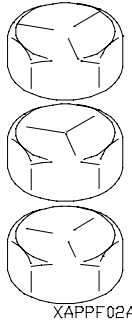
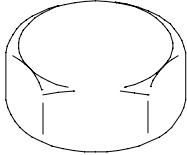
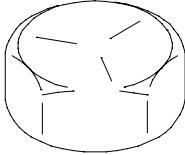
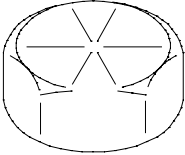
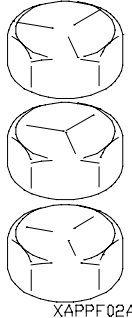
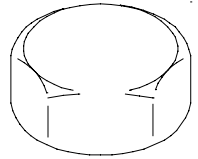
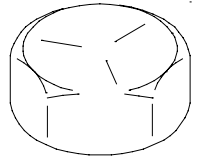
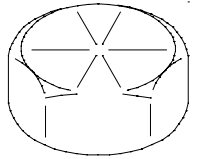
		Material Grade Markings				
		 XAPPF061 SAE Grade 5				 XAPPF071 SAE Grade 8
Hole Diameter	Threads per inch	Torque				
		lb-ft	N-m	lb-ft	N-m	
1/4	20	10-12	14-16	15-17	20-24	
1/4	28	12-14	16-18	14-18	21-25	
5/16	18	20-24	27-33	26-32	36-44	
5/16	24	22-26	30-36	29-35	40-48	
3/8	16	35-41	47-55	48-58	65-77	
3/8	24	38-46	53-63	53-63	72-86	
7/16	14	55-65	74-88	75-91	103-123	
7/16	20	60-70	81-97	80-98	110-132	
1/2	13	86-102	116-138	113-137	154-184	
1/2	20	92-110	125-149	127-153	177-207	
9/16	12	120-144	162-194	168-202	229-273	
9/16	18	135-161	183-219	179-217	244-294	
5/8	11	165-199	226-270	226-272	306-368	
5/8	18	181-219	246-296	244-296	331-401	
3/4	10	296-354	402-480	395-479	538-648	
3/4	16	310-376	422-508	424-516	576-698	
7/8	9	460-554	625-749	612-746	833-1009	
7/8	14	503-607	684-822	652-800	888-1082	
1	8	686-828	933-1121	941-1141	1280-1544	

Table F-3. Dry Torque Limits for Metric Screws and Free Spinning Nuts

		Material Grade Markings							
		 XAPPF081 Metric Grade 4.8	 XAPPF091 Metric Grade 8.8	 XAPPF101 Metric Grade 10.9	 XAPPF111 Metric Grade 12.9				
Diameter	Thread Pitch	Torque							
		lb-ft	N-m	lb-ft	N-m	lb-ft	N-m	lb-ft	N-m
6	1	3	4-5	5-7	7-9	7-9	10-13	8-11	11-15
8	1.25	7-9	9-11	13-17	17-23	17-23	23-31	21-27	27-37
8	1	7-9	9-13	14-18	18-24	19-25	25-33	21-29	29-39
10	1.5	13-17	17-23	25-33	33-45	34-46	46-62	40-54	54-72
10	1.25	14-18	18-24	26-34	35-47	36-48	49-65	42-56	57-77
10	0.75	15-19	21-27	29-39	39-53	40-54	54-72	47-63	63-85
12	1.75	22-30	30-40	43-57	58-78	60-80	81-107	69-93	94-126
12	1.5	23-31	32-42	46-60	61-81	63-83	85-113	73-97	99-131
12	1.25	24-32	33-45	47-63	65-85	65-87	88-118	76-102	104-138
12	1	26-34	34-46	49-65	67-89	68-90	93-123	80-106	108-144
14	2	36-48	48-74	69-91	93-125	95-127	129-173	112-148	151-201
14	1.5	39-51	52-70	75-99	99-135	103-137	140-186	120-160	163-217
15	1	51-69	69-93	100-132	135-179	137-183	187-249	160-214	218-290
16	2	55-73	75-99	107-143	145-193	148-198	201-267	173-231	235-313
16	1.5	59-79	80-106	114-152	155-207	158-210	214-286	184-246	250-334
18	1.5			166-222	225-301	230-306	311-415	268-358	364-486
20	2.5			209-279	283-377	289-385	392-522	338-450	458-610
20	1.5			232-308	315-419	321-427	435-579	375-499	508-678
20	1			244-324	330-440	337-449	457-609	394-524	534-712
22	2.5			285-379	387-515	394-524	534-712	461-613	624-832
22	1.5			313-417	424-566	432-576	586-782	664-884	900-1200
24	3			361-481	489-653	499-665	677-903	584-778	791-1055
24	2			394-524	534-712	545-725	738-984	725-965	982-1310
25	1.5			467-621	633-843	645-859	875-1167	754-1004	1023-1363

APPENDIX F TORQUE LIMITS

Table F-4. Dry Torque Limits for Metric Prevailing Torque Nuts

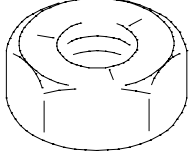
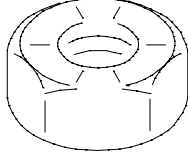
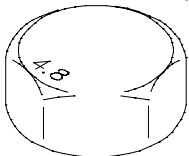
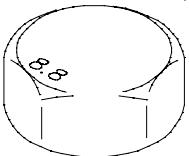
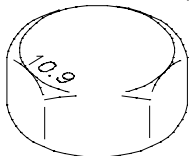
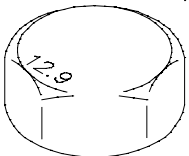
		Material Grade Markings							
		 XAPPF121 Metric Grade 4.8	 XAPPF131 Metric Grade 8.8	 XAPPF141 Metric Grade 10.9			 XAPPF151 Metric Grade 12.9		
Diameter	Thread Pitch	Torque							
		lb-ft	N-m	lb-ft	N-m	lb-ft	N-m	lb-ft	N-m
6	1	5-6	7-8	7-9	10-12	10-12	14-17	11-14	15-19
8	1.25	12-14	16-18	18-22	24-30	24-30	32-40	27-33	36-46
8	1	12-14	16-20	19-23	25-31	25-31	34-42	28-36	38-48
10	1.5	21-25	28-34	33-41	44-56	44-56	60-76	50-64	68-86
10	1.25	21-25	29-35	34-42	46-58	46-58	63-79	53-67	71-91
10	0.75	23-27	31-37	37-47	49-63	50-64	68-86	57-73	77-99
12	1.75	33-41	46-56	55-69	74-94	75-95	102-128	85-109	115-147
12	1.5	35-43	47-57	56-72	77-97	78-98	106-134	89-113	120-152
12	1.25	36-44	48-60	58-74	79-101	81-103	109-139	91-117	125-159
12	1	37-45	50-62	61-77	82-104	84-106	114-144	95-121	129-165
14	2	53-65	72-88	87-109	117-149	118-150	160-204	134-172	182-232
14	1.5	57-69	76-94	92-116	125-159	126-160	171-217	143-183	194-248
16	2	79-97	107-131	130-166	177-225	178-228	243-309	204-262	277-355
16	1.5	82-102	112-138	138-176	187-239	189-241	256-328	215-277	292-376
18	1.5			197-253	267-343	271-347	367-471	309-399	420-542
20	2.5			248-318	337-431	342-438	464-594	391-503	530-682
20	1.5			271-349	369-473	374-480	507-651	428-552	580-750
20	1			283-365	384-494	390-502	529-681	447-577	606-784
22	2.5			335-429	455-583	460-592	624-802	526-680	714-922
22	1.5			363-467	492-634	499-643	676-872	730-950	990-1290
24	3			420-540	569-733	577-743	783-1009	662-856	897-1161
24	2			453-583	614-792	622-804	844-1090	803-1043	1088-1416

Table F-5. Wet Torque Limits for SAE and ANSI Screws and Free Spinning Nuts

 NOTE Manufacturer's marks may vary. These are all SAE Grade 5.		Material Grade Markings					
		 SAE Grade 2	 SAE Grade 5	 SAE Grade 8	Torque		
Diameter	Threads per inch	lb-ft	N-m	lb-ft	N-m	lb-ft	N-m
inch							
1/4	20	4	6	6	8	9	12
1/4	28	5	7	7	9	10	14
5/16	18	8	11	13	18	18	24
5/16	24	9	12	14	19	20	27
3/8	16	15	20	23	31	35	47
3/8	24	17	23	25	34	35	47
7/16	14	24	33	35	47	55	75
7/16	20	25	34	40	54	60	81
1/2	13	35	47	55	75	80	108
1/2	20	40	54	65	88	90	122
9/16	12	50	68	80	108	110	149
9/16	18	55	75	90	122	130	176
5/8	11	70	95	110	149	170	231
5/8	18	80	108	130	176	180	244
3/4	10	120	163	200	271	280	380
3/4	16	140	190	220	298	320	434
7/8	9	110	149	300	407	460	624
7/8	14	120	163	320	434	500	678
1	8	160	217	440	597	680	922
1	12	170	231	480	651	740	1003
1-1/8	7	220	298	600	814	960	1302
1-1/8	12	260	353	660	895	1080	1464

APPENDIX F TORQUE LIMITS

Table F-5. Wet Torque Limits for SAE and ANSI Screws and Free Spinning Nuts (Cont)

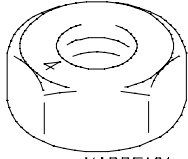
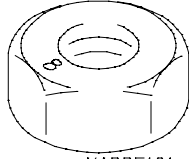
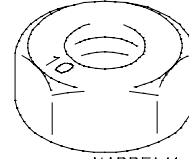
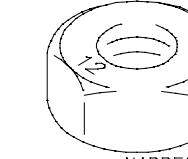
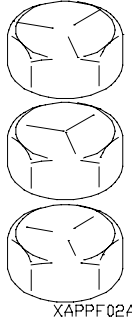
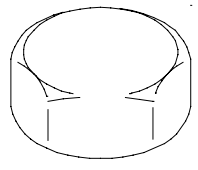
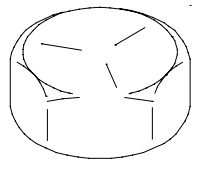
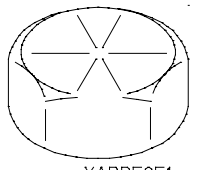
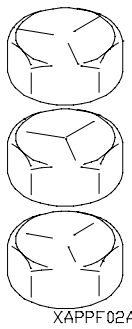
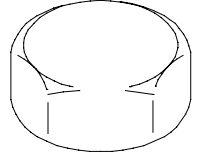
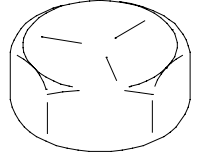
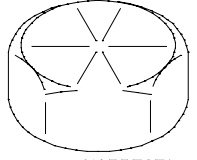
 <p style="text-align: center; font-size: small;">XAPPF02A</p> <p style="text-align: center;">Manufacturer's marks may vary. These are all SAE Grade 5</p>		Material Grade Markings					
		 <p style="text-align: center; font-size: small;">XAPPF03A</p> <p style="text-align: center;">SAE Grade 2</p>		 <p style="text-align: center; font-size: small;">XAPPF04A</p> <p style="text-align: center;">SAE Grade 5</p>		 <p style="text-align: center; font-size: small;">XAPPF051</p> <p style="text-align: center;">SAE Grade 8</p>	
		Torque					
Diameter	Threads per inch						
inch		lb-ft	N·m	lb-ft	N·m	lb-ft	N·m
1-1/4	7	320	434	840	1139	1360	1844
1-1/4	12	360	488	920	1248	1500	2034
1-3/8	6	420	570	1100	1492	1780	2414
1-3/8	12	460	624	1260	1709	2040	2766

APPENDIX G MANDATORY REPLACEMENT PARTS

Section I. INTRODUCTION

G-1. SCOPE

This appendix lists mandatory replacement parts you will need to maintain the MTV vehicle.

G-2. EXPLANATION OF COLUMNS

- a. **Column (1) - Item Number.** This number is assigned to each entry in the listing and is referenced in the Initial Setup of the applicable task under Materials/Parts.
- b. **Column (2) - Nomenclature.** Name or identification of the part.
- c. **Column (3) - Part Number.** The manufacturer's part number.
- d. **Column (4) - National Stock Number.** The National stock number of the part.

Section II. MANDATORY REPLACEMENT PARTS LIST

(1) ITEM NO.	(2) NOMENCLATURE	(3) PART NUMBER	(4) NATIONAL STOCK NUMBER
1	BLADE, WINDSHIELD WIPER	105.384	2540-01-364-1621
2	BOLT, MACHINE	12414307-065	5306-01-382-5054
3	BOOT KIT, EXHAUST	DQ6025	4730-01-417-3197
4	BUMPER, NONMETALLIC	1011-05	5340-01-342-1110
5	BUMPER, RUBBER	12419182	5340-01-410-8397
6	BUSHING, SLEEVE	7-199-002668	3120-01-367-6894
7	CHANNEL, RUBBER	ZZR765/2-001A7	9390-01-420-4560
8	CLAMP	024S9	4730-01-447-4312
9	CLAMP	032S9	4730-01-447-4313
10	COVER, FLUID FILTER	12412628	2590-01-414-1243
11	DECAL	12340917	7690-01-256-4909
12	FASTENER TAPE	MIL-F-21840	8315-00-006-9855
13	FASTENER TAPE	50-534718-19	8315-00-935-6762
14	FILTER ASSEMBLY	75223-11	2940-01-417-9333

Section II. MANDATORY REPLACEMENT

PARTS LIST (CONT)

(1) ITEM NO.	(2) NOMENCLATURE	(3) PART NUMBER	(4) NATIONAL STOCK NUMBER
15	FILTER ELEMENT	1048011	2940-01-385-8931
16	FILTER ELEMENT, FLUID	K05-0104	2910-01-377-3128
17	FILTER ELEMENT, FLUID	R22146	2910-01-360-6366
17.1	FILTER ELEMENT, FLUID	ST117073098-000	2910-01-467-4594
18	FILTER ELEMENT, FLUID	29507750	2940-01-361-2405
19	FILTER ELEMENT, FLUID	599791	4460-01-284-2344
20	FILTER ELEMENT, FLUID	931558	2940-01-363-4377
21	FILTER ELEMENT, INTAKE AIR CLEANER	P52-7750	2940-01-361-2407
22	FILTER, FUEL	7E9763	2910-01-363-3089
23	FILTER, OIL	1R0739	2940-00-029-0388
24	GASKET	F337576M6	
25	GASKET	M28840/24HA	5935-01-421-9754
26	GASKET	QS-1181	5330-01-058-3788
27	GASKET	10-36675-18	5330-00-298-0190
27.1	GASKET	11446	5330-00-247-4174
28	GASKET	119-2940	5330-01-424-7905
29	GASKET	12412394	5330-01-371-6199
29.1	GASKET	12421155	5330-01-295-0115
29.2	GASKET	12421469	5330-01-453-2980
29.3	GASKET	3N4087	5330-01-061-8003
30	GASKET	350700	5330-01-295-3053
31	GASKET	350903	5330-00-576-4626
32	GASKET	352200	5330-01-421-6105
33	GASKET	352302	5330-01-421-6107
34	GASKET	353400	5330-01-421-6102
35	GASKET	353806	5330-01-421-6103
36	GASKET	353810	5330-01-450-6666
37	GASKET	355148	5330-01-423-0596
38	GASKET	355175	5330-01-423-0623
39	GASKET	3K3257	5330-01-305-6550
40	GASKET	4P1624	5330-01-360-5934

Section II. MANDATORY REPLACEMENT PARTS LIST (CONT)

(1) ITEM NO.	(2) NOMENCLATURE	(3) PART NUMBER	(4) NATIONAL STOCK NUMBER
41	GASKET	4W0549	5330-01-347-3207
42	GASKET	9Y8103	5330-01-360-5931
43	GASKET and PREFORMED PACKING KIT	P4-4	5330-00-122-0624
43.1	GASKET and PREFORMED PACKING SET	9X8318	5330-01-360-9098
44	GASKET, FUEL FILTER	7C1159	5330-01-360-5941
45	NOT USED		
46	GASKET, THERMOSTAT	2W7212	5330-01-347-3206
47	GROMMET, NONMETALLIC	MS21266-3N	5325-00-926-1394
48	GROMMET, NONMETALLIC	MS35489-109	5325-00-290-0074
49	GROMMET, NONMETALLIC	MS35489-6	5325-00-263-6632
50	GROMMET, NONMETALLIC	12412334-2	9320-01-456-1672
51	GROMMET, NONMETALLIC	12417598	5325-01-375-1299
52	GROMMET, NONMETALLIC	12421402	5325-01-440-2178
53	GROMMET, NONMETALLIC	4082-37634-01	5325-01-194-3076
54	GROMMET, NONMETALLIC	50S12-1-1AA	5325-01-145-0105
55	GROMMET, NONMETALLIC	8741442	5325-00-088-6147
56	INDICATOR, SIGHT, LIQUID	SLT-1214	6680-01-356-8162
57	INSERT, NYLON	12SWS2520	5310-01-439-8881
58	INSERT, NYLON	12SWS2542	5310-01-439-8883
59	INSERT, NYLON	12421463-003	5310-01-453-2087
60	INSULATOR, TANK	A1394J	5970-01-385-7317
61	INSULATOR, TANK	A1394K	5970-01-385-7262
62	NOT USED		
63	KIT, FILTER	29526899	5330-01-453-0770
64	KIT, FILTER	29503829	
65	LAMP, INCANDESCENT	CM7-7373	6240-00-270-6824
66	LAMP, INCANDESCENT	CM7376	6240-00-499-6278
67	LATCH, BAIL HEAD	68-20-101-10	2540-01-232-2470
68	LOCKNUT	0770-023-003	5310-01-423-3725
69	LOCKWASHER	ABCH207-LW-1/2	
70	LOCKWASHER	ABCH207-LW-3/8	

Section II. MANDATORY REPLACEMENT PARTS LIST (CONT)

(1) ITEM NO.	(2) NOMENCLATURE	(3) PART NUMBER	(4) NATIONAL STOCK NUMBER
71	LOCKWASHER	D70336/1-20	5310-01-110-7933
72	LOCKWASHER	D70336/3-50	5310-01-439-2542
73	LOCKWASHER	D70336/3-52	5310-01-439-2543
74	LOCKWASHER	MS35333-136	5310-01-078-9699
75	LOCKWASHER	MS35333-78	5310-00-261-7156
76	LOCKWASHER	MS35335-30	5310-00-209-0788
77	LOCKWASHER	MS35335-31	5310-00-596-7693
78	LOCKWASHER	MS35335-33	5310-00-209-0786
79	LOCKWASHER	MS35335-36	5310-00-550-3503
80	LOCKWASHER	MS35335-37	5310-00-209-5116
81	LOCKWASHER	MS35335-38	5310-00-616-6354
82	LOCKWASHER	MS35335-58	5310-00-209-1366
83	LOCKWASHER	MS35335-61	5310-00-527-3634
84	LOCKWASHER	MS35335-62	5310-00-184-9562
85	LOCKWASHER	MS35337-25	5310-00-012-1637
86	LOCKWASHER	MS35338-100	5310-00-261-8278
87	LOCKWASHER	MS35338-103	5310-00-184-8971
88	LOCKWASHER	MS35338-137	5310-00-933-8119
89	LOCKWASHER	MS35338-138	5310-00-933-8120
90	LOCKWASHER	MS35338-141	5310-00-984-7042
90.1	LOCKWASHER	MS35338-147	5310-00-926-5871
91	LOCKWASHER	MS35338-41	5310-00-045-4007
92	LOCKWASHER	MS35338-42	5310-00-045-3299
93	LOCKWASHER	MS35338-43	5310-00-045-3296
94	LOCKWASHER	MS35338-44	5310-00-582-5965
95	LOCKWASHER	MS35338-45	5310-00-407-9566
96	LOCKWASHER	MS35338-46	5310-01-334-4710
97	LOCKWASHER	MS35338-47	5310-00-209-0965
98	LOCKWASHER	MS35338-51	5310-00-584-7888
99	LOCKWASHER	MS35338-58	5310-00-702-6286
100	LOCKWASHER	MS51414-1	5310-01-235-2057

Section II. MANDATORY REPLACEMENT PARTS LIST (CONT)

(1) ITEM NO.	(2) NOMENCLATURE	(3) PART NUMBER	(4) NATIONAL STOCK NUMBER
101	LOCKWASHER	MS51414-2	5310-01-310-1098
102	LOCKWASHER	MS51414-4	5310-01-251-9276
103	LOCKWASHER	N9015	5310-01-046-0186
104	LOCKWASHER	N9459	5310-01-348-8393
105	LOCKWASHER	N9461	5310-01-348-8392
105.1	LOCKWASHER	XP1113	5310-01-460-5991
105.2	LOCKWASHER	10241	5310-01-416-3010
106	LOCKWASHER	114021	5310-01-081-0798
107	LOCKWASHER	1229-S-513-C	5310-01-062-3384
108	LOCKWASHER	12412477-14	
109	LOCKWASHER	12412601-02	5310-01-387-1152
110	LOCKWASHER	12414570-005	5310-01-452-9420
111	LOCKWASHER	12414570-011	5310-01-374-3292
112	LOCKWASHER	12414570-013	5310-01-374-4515
113	LOCKWASHER	12414570-015	5310-01-388-2043
114	LOCKWASHER	12414570-021	5310-01-374-4516
115	NOT USED		
116	NOT USED		
117	NOT USED		
118	LOCKWASHER	1729B262	5310-00-964-7811
119	NOT USED		
120	MOUNT, RESILIENT	12413126	5340-01-439-3765
121	MOUNT, RESILIENT	12418476	5340-01-377-0693
122	NUT, CLIP	MS90724-24	5310-01-074-5041
123	NUT, CONDUIT	BL75	5975-00-642-7261
124	NUT, CONDUIT	141	5975-00-152-1075
125	NUT, CONDUIT	143	5975-00-714-8031
126	NUT, PLAIN, BLIND RIVET	ALS7-632-80	5325-01-465-0001
127	NUT, PLAIN, HEX	MS35649-282	5310-00-934-9757
127.1	NUT, PLAIN, ROUND	1727N40	5310-00-123-2572
128	NUT, SELF-LOCKING	DIN-934STM6	5310-01-342-2739

Section II. MANDATORY REPLACEMENT PARTS LIST (CONT)

(1) ITEM NO.	(2) NOMENCLATURE	(3) PART NUMBER	(4) NATIONAL STOCK NUMBER
129	NUT, SELF-LOCKING	MS20500-524	5310-00-208-4023
130	NUT, SELF-LOCKING	MS21042-04	5310-00-811-6419
130.1	NUT, SELF-LOCKING	MS21045L5	5310-00-857-5559
131	NUT, SELF-LOCKING	MS21083N08	5310-00-941-6019
132	NUT, SELF-LOCKING	MS21083N6	5310-00-926-1852
133	NUT, SELF-LOCKING	MS51922-1	5310-00-088-1251
134	NUT, SELF-LOCKING	MS51922-17	5310-00-087-4652
135	NUT, SELF-LOCKING	MS51922-2	5310-00-929-1807
136	NUT, SELF-LOCKING	MS51922-33	5310-00-225-6993
137	NUT, SELF-LOCKING	MS51922-49	5310-00-269-4040
138	NUT, SELF-LOCKING	MS51922-5	5310-00-959-7600
139	NUT, SELF-LOCKING	MS51922-57	5310-00-067-6356
140	NUT, SELF-LOCKING	MS51922-65	5310-00-225-6992
141	NUT, SELF-LOCKING	MS51922-9	5310-00-984-3806
142	NUT, SELF-LOCKING	N9406	5310-01-362-6171
143	NUT, SELF-LOCKING	N9410	5310-01-348-8398
143.1	NUT, SELF-LOCKING	N9453	5310-01-348-8314
144	NUT, SELF-LOCKING	N9467	5310-01-350-4257
144.1	NUT, SELF-LOCKING	N9556	5310-01-423-0880
145	NUT, SELF-LOCKING	12301125	5310-01-210-0199
146	NUT, SELF-LOCKING	12412476-09	5310-01-445-6346
147	NUT, SELF-LOCKING	12412476-11	5310-01-407-7178
148	NUT, SELF-LOCKING	12412476-12	
149	NUT, SELF-LOCKING	12412478-04	5310-01-381-9901
150	NUT, SELF-LOCKING	12414308-002	5310-01-381-9819
151	NUT, SELF-LOCKING	12414308-003	5310-01-377-1549
152	NUT, SELF-LOCKING	12414308-004	5310-01-369-5703
153	NUT, SELF-LOCKING	12414308-007	5310-01-369-6073
154	NUT, SELF-LOCKING	12414308-017	5310-01-381-9830
155	NUT, SELF-LOCKING	12414308-018	5310-01-369-3337
156	NUT, SELF-LOCKING	12414308-019	5310-01-369-9522

Section II. MANDATORY REPLACEMENT PARTS LIST (CONT)

(1) ITEM NO.	(2) NOMENCLATURE	(3) PART NUMBER	(4) NATIONAL STOCK NUMBER
157	NUT, SELF-LOCKING	12414308-020	5310-01-381-9849
158	NUT, SELF-LOCKING	12414308-021	5310-01-369-3338
159	NUT, SELF-LOCKING	12414308-022	5310-01-417-1262
160	NUT, SELF-LOCKING	12414308-023	5310-01-369-6705
161	NUT, SELF-LOCKING	12414308-025	5310-01-369-6706
162	NUT, SELF-LOCKING	12414308-027	5310-01-369-3339
163	NUT, SELF-LOCKING	12414308-078	
164	NUT, SELF-LOCKING	12414315-002	5310-01-374-1381
165	NUT, SELF-LOCKING	12414315-003	5310-01-374-1382
166	NUT, SELF-LOCKING	12414315-005	5310-01-372-3023
167	NUT, SELF-LOCKING	12414315-006	5310-01-369-3332
168	NUT, SELF-LOCKING	12414315-009	5310-01-365-7236
169	NUT, SELF-LOCKING	12414315-015	5310-01-462-0580
170	NUT, SELF-LOCKING	12414315-017	5310-01-368-8065
171	NUT, SELF-LOCKING	12414420-004	5310-01-370-0010
172	NUT, SELF-LOCKING	12419003	5310-01-376-0773
173	NUT, SELF-LOCKING	29514660	
174	NUT, SELF-LOCKING	7-660-081600	5310-01-390-8487
175	NUT, SELF-LOCKING	7-660-082504	5310-01-354-8734
176	NUT, SELF-LOCKING	7794625	5310-00-579-1031
177	NUT, SELF-LOCKING	7951286	5310-00-789-0398
178	PACKING, PREFORMED	A82777	5330-00-579-6495
178.1	PACKING, PREFORMED	F4001-16	5331-01-466-0354
179	PACKING, PREFORMED	J515-16-3	5331-01-465-3634
180	PACKING, PREFORMED	5999807	5331-01-456-9156
181	PACKING, PREFORMED	MS28775-011	5330-00-582-2133
181.1	PACKING, PREFORMED	MS28775-910	5331-00-448-6753
182	PACKING, PREFORMED	MS28778-10	5330-00-285-9842
183	PACKING, PREFORMED	MS28778-12	5330-00-251-8839
184	PACKING, PREFORMED	MS28778-16	5330-00-804-5694
185	PACKING, PREFORMED	MS28778-20	5330-00-816-3546

Section II. MANDATORY REPLACEMENT PARTS LIST (CONT)

(1) ITEM NO.	(2) NOMENCLATURE	(3) PART NUMBER	(4) NATIONAL STOCK NUMBER
186	PACKING, PREFORMED	MS28778-4	5330-00-805-2966
187	PACKING, PREFORMED	MS28778-6	5330-00-804-5695
188	PACKING, PREFORMED	MS9955-113	5330-01-374-2325
189	PACKING, PREFORMED	M25988/1-246	5330-01-189-6351
189.1	PACKING, PREFORMED	M83461/1-442	5330-01-183-0987
190	PACKING, PREFORMED	OR420A	5330-01-389-6028
191	PACKING, PREFORMED	11639519-1	5330-00-463-0200
192	PACKING, PREFORMED	1509	5330-00-172-1919
192.1	PACKING, PREFORMED	195045	5331-00-618-5361
192.2	PACKING, PREFORMED	19755	5331-01-415-9632
192.3	PACKING, PREFORMED	198336	5331-00-584-1840
193	PACKING, PREFORMED	2-012N507-90	5330-01-092-5502
194	PACKING, PREFORMED	2-018N507-90	5330-01-092-5503
195	PACKING, PREFORMED	2M4453	5330-00-074-3768
196	PACKING, PREFORMED	22617-16	5330-01-168-0885
197	PACKING, PREFORMED	23043446	5330-01-424-6629
197.1	PACKING, PREFORMED	250192	5331-01-417-5105
197.2	PACKING, PREFORMED	251216	5330-01-417-5107
198	PACKING, PREFORMED	29500969	5330-01-360-7852
199	PACKING, PREFORMED	29503383	5330-01-360-6017
200	PACKING, PREFORMED	3-906N552-90	5330-01-104-1093
201	PACKING, PREFORMED	3-908N552-90	5330-00-929-8171
202	PACKING, PREFORMED	3D2824	5330-00-944-8281
203	PACKING, PREFORMED	3J1907	5330-01-333-6444
204	PACKING, PREFORMED	3J7354	5330-00-952-8008
205	PACKING, PREFORMED	3K0360	5330-00-948-6482
206	PACKING, PREFORMED	4J5477	5330-00-855-8059
207	PACKING, PREFORMED	4L9564	5330-00-828-8639
207.1	PACKING, PREFORMED	420828	5340-01-417-3788
208	PACKING, PREFORMED	5-X-1155	5330-01-392-1637
209	PACKING, PREFORMED	5F7054	5330-00-339-6224

Section II. MANDATORY REPLACEMENT PARTS LIST (CONT)

(1) ITEM NO.	(2) NOMENCLATURE	(3) PART NUMBER	(4) NATIONAL STOCK NUMBER
210	PACKING, PREFORMED	5P7813	5330-01-335-0042
211	PACKING, PREFORMED	6V8397	5330-00-579-6495
212	PACKING, PREFORMED	673268	
213	PACKING, PREFORMED	673269	5330-01-395-1252
214	PACKING, PREFORMED	7F8267	5330-00-291-7353
215	PACKING, PREFORMED	7320658	5330-00-297-7106
216	PACKING, PREFORMED	9604792-001	5330-01-429-3089
217	PAD, CUSHIONING	12413120	2590-01-474-8307
218	PARTS KIT, DEHYDRATOR	RN-60-A	4440-01-337-7324
219	PARTS KIT, HYDRAULIC PUMP	P1-12RP	4320-00-125-3208
220	PARTS KIT, SEAL REPLACEMENT	SK10-2	5330-01-350-4474
221	PARTS KIT, SEAL REPLACEMENT	SK10-3	5330-01-350-4472
222	PARTS KIT, SEAL REPLACEMENT	SK10-4	5330-01-343-2745
222.1	PARTS KIT, SEAL REPLACEMENT, MECHANICAL	SKD1VW	5330-01-309-2603
223	PIN, COTTER	K-2412-Z	5315-01-179-9882
224	PIN, COTTER	MS24665-151	5315-00-815-1405
225	PIN, COTTER	MS24665-298	5315-00-234-1861
226	PIN, COTTER	MS24665-385	5315-00-187-9382
227	PIN, COTTER	MS24665-394	5315-00-234-1628
228	PIN, COTTER	MS24665-423	5315-00-013-7228
229	PIN, COTTER	MS24665-455	5315-00-187-9392
230	PIN, COTTER	MS24665-457	5315-00-187-9393
231	PIN, COTTER	MS24665-459	5315-00-187-9394
232	PIN, COTTER	MS24665-494	
233	PIN, COTTER	MS24665-498	5315-00-849-9854
234	PIN, COTTER	MS24665-628	5315-00-846-0126
235	PIN, COTTER	MS24665-654	5315-00-187-9413
236	PIN, COTTER	MS24665-69	5315-00-828-8190
236.1	PIN, COTTER	XB-781-1	5315-01-369-1346
237	NOT USED		
238	PIN, SPRING	MS16562-142	5315-00-058-6115

Section II. MANDATORY REPLACEMENT PARTS LIST (CONT)

(1) ITEM NO.	(2) NOMENCLATURE	(3) PART NUMBER	(4) NATIONAL STOCK NUMBER
239	PIN, SPRING	MS16562-146	5315-00-853-3814
240	PLASTIC STRIP	352700	5330-01-396-2109
241	RECEPTACLE	50R4-1-1AA	5325-01-049-2049
241.1	REPAIR KIT, GOVERNOR	RN32W	
241.2	RETAINER, PACKING	11863-012	5330-01-417-7795
241.3	RETAINER, PACKING	202624	5330-01-417-7794
242	NOT USED		
243	RIVET, BLIND	AD66H	5320-01-008-8204
243.1	RIVET, BLIND	MS20601AD5W3	5320-00-582-3299
243.2	RIVET, BLIND	MS20601B4W2	5320-00-616-5274
244	RIVET, BLIND	MS20604B3W2	5320-00-721-9075
245	RIVET, BLIND	M24243/1-B302	5320-00-999-0397
246	RIVET, BLIND	M24243/1-B610	5320-00-454-5156
247	RIVET, BLIND	M24243/1-D404	5320-00-865-8994
248	RIVET, BLIND	M24243/1-D502	5320-00-850-3248
249	RIVET, BLIND	M24243/1-D504	5320-01-020-9756
250	RIVET, BLIND	M24243/1-D506	5320-00-850-3225
251	RIVET, BLIND	M24243/1-D604	5320-00-850-3233
252	RIVET, BLIND	M24243/1-D608	5320-00-850-3246
253	RIVET, BLIND	M24243/1-D610	5320-01-030-3218
254	RIVET, BLIND	M24243/1-F402	5320-00-129-9706
254.1	RIVET, BLIND	M24243/1F608	5320-01-392-0699
254.2	RIVET, BLIND	M24243/1F610	
255	RIVET, BLIND	M24243/6-A503H	5320-00-490-2238
256	RIVET, BLIND	NAS1398C5A4	5320-00-321-2521
257	RIVET, BLIND	SD64BSLF	5320-01-397-3347
258	RIVET, BLIND	206057	5320-01-411-0081
259	RIVET, COMPRESSION	12418469	5320-01-376-0699
260	RUBBER STRIP	12412581	9320-01-399-4888
260.1	SCREW, CAP	CSH5-24-39	5305-01-479-7857
261	SCREW, CAP	12414475-131	5303-01-363-0703

Section II. MANDATORY REPLACEMENT PARTS LIST (CONT)

(1) ITEM NO.	(2) NOMENCLATURE	(3) PART NUMBER	(4) NATIONAL STOCK NUMBER
262	SCREW, CAP	6V-2315	5306-01-433-4753
263	SCREW, SELF-LOCKING	MS16998-61L	5305-01-211-3097
264	SEAL	VC08G1R0B	5330-01-389-6109
265	SEAL	355150	5330-01-423-0689
266	SEAL ASSEMBLY, CTIS	A1205-Q-2435	5330-01-360-7753
267	SEAL ASSEMBLY, HUB	A1205-R-2254	5330-01-360-5252
268	SEAL RING, METAL	29505809	5330-01-360-5329
269	SEAL, NONMETALLIC	CC3350	5330-01-431-7575
270	SEAL, NONMETALLIC	12417725	5330-01-375-2908
271	SEAL, NONMETALLIC	673999	5310-01-454-5553
271.1	SEAL, PLAIN	N72143	5330-01-453-4462
271.2	SEAL, SHAFT	SE-RUR25-2	5330-01-135-3376
272	SEAL, URETHANE FOAM	12420420-001	5680-01-453-8912
273	SEAL, URETHANE FOAM	12420420-002	5680-01-453-8485
274	SEAL, URETHANE FOAM	12420420-003	5680-01-453-8486
274.1	SEMICONDUCTOR DEVICE, DIODE	JANTX1N3957	5961-00-181-0661
274.2	SPIDER, UNIVERSAL JOINT, VEHICULAR	R279X	
274.3	SPLICE, CONDUCTOR	M7928/5-4	5940-01-079-1375
274.4	SPLICE, CONDUCTOR	M83519/1-2	5940-01-136-2540
274.5	SPLICE, CONDUCTOR	M83519/1-3	5940-01-135-7077
274.6	SPLICE, CONDUCTOR	M83519/1-5	5940-01-135-7079
274.7	SPLICE, CONDUCTOR	12420927-001	5940-01-456-1319
275	SPLICE, CONDUCTOR	23035	5940-01-210-9261
276	SPLICE, CONDUCTOR	23075	3830-01-210-9260
277	TERMINAL, LUG	MS20659-163	5940-00-113-3145
278	TERMINAL, LUG	MS20659-164	5940-00-113-3148
279	TERMINAL, LUG	MS25036-122	5940-00-113-8190
279.1	WASHER, FLAT	12414473-010	5310-01-374-6990
280	WASHER, FLAT	12417948-004	5365-01-436-8308
280.1	WASHER, FLAT	251391	5310-01-417-1041
280.2	WASHER, FLAT	990 3861	5310-01-155-1911

Section II. MANDATORY REPLACEMENT PARTS LIST (CONT)

(1) ITEM NO.	(2) NOMENCLATURE	(3) PART NUMBER	(4) NATIONAL STOCK NUMBER
281	WASHER, FLAT RUBBER	900.032	5330-01-378-7541
282	WASHER, KEY	TW107	5310-01-014-5136
283	WASHER, NYLON	MS51859-16	5310-01-381-9990
284	WASHER, NYLON	12421464-001	
285	WASHER, NYLON	12421464-002	5310-01-445-6828
286	WASHER, SPRING	D63474/1-30	5310-01-413-8475
287	WASHER, SPRING	110 7289	5310-01-246-1387
288	WASHER, SPRING	12414559-021	5310-01-374-4517
289	WASHER, SPRING	12414560-009	5310-01-333-5517
290	WASHER, SPRING	12414560-011	5310-01-421-9556
291	WASHER, SPRING	12414560-017	5310-01-395-0820
292	WASHER, SPRING	12414560-018	5310-01-381-3281
293	WASHER, SPRING	12414560-019	5310-01-369-6074
294	WASHER, SPRING	12417503	5310-01-406-6326
295	WASHER, SPRING	12418220	5310-01-372-3495
296	WASHER, SPRING	128BSTM4	5310-01-333-5517

APPENDIX H LUBRICATION ORDER

SECTION I. INTRODUCTION

H-1. GENERAL

The information contained in this appendix provides the lubrication requirements for the MTV vehicle.

- a. Adherence.** Intervals (on-condition or hardtime) and the related man-hour times are based on normal operation. The man-hour time specified is the time needed to do all the services prescribed for a particular interval. On-condition (OC) oil sample intervals will be applied unless changed by the Army Oil Analysis Program (AOAP) laboratory. Change the hardtime interval if the lubricants are contaminated or if operating the equipment under adverse operating conditions, including longer-than-usual operating hours. The calendar interval may be extended during periods of low activity. If extended, adequate preservation precautions must be taken. Hardtime intervals will be applied in the event AOAP laboratory support is not available. Hardtime intervals must be applied during the warranty period.

Intervals shown in this lubrication order are based on mileage/calendar, and in some cases mileage alone. An example of a mileage/calendar interval is: **Q**, which means every 3,000 miles (4,827 km) or quarterly (every three months). The lubrication is to be performed at whichever interval occurs first for the vehicle. An example of a mileage alone interval is: **6K**, which stands for every 6,000 miles (9,654 km). The lubrication is to be performed at the mileage indicated regardless of the calendar interval.

WARNING

- **Dry Cleaning Solvent (P-D-680) is TOXIC and flammable. Wear protective goggles and gloves; use only in well-ventilated area; avoid contact with skin, eyes, and clothes, and do not breath vapors. Keep away from heat or flame. Never smoke when using solvent; the flashpoint for Type I Dry Cleaning Solvent is 100°F (38°C) and for Type II is 138°F (50°C). Failure to comply may result in serious injury or death to personnel.**
 - **If personnel become dizzy while using cleaning solvent, immediately get fresh air and medical help. If solvent contacts skin or clothes, flush with cold water. If solvent contacts eyes, immediately flush eyes with water and get medical attention. Failure to comply may result in injury to personnel.**
- b. Cleaning fittings before lubricating.** Clean parts with dry cleaning solvent (SD P-D-680) (Item 65, Appendix D) or equivalent. Dry before lubricating. Dashed arrows indicate lubrication on both sides of the equipment.
- c. Lubricating after fording.** If fording occurs, lubricate all fittings below fording depth and check submerged gearboxes for presence of water.
- d. Lubricating after high-pressure washing.** After a thorough washing, lubricate all grease fittings and oil can points outside and underneath vehicle.
- e. Level of Maintenance.** The lowest level of maintenance authorized to lubricate a point is Operator/Unit Maintenance (O). Operator/crew (C) may lubricate points authorized for Unit Maintenance (O) when authorized by Unit Maintenance (O).
- f. Localized views.** A reference to the appropriate localized view is given after most lubrication entries. Localized views begin on page H-13.

H-1. GENERAL (CONT)

g. Interval Symbols. The lubrications interval symbols will be used as applicable:

- Q-quarterly/3,000 mi (4,827 km) (whichever occurs first)
- S-semiannually/6,000 mi (9,654 km) (whichever occurs first)
- A-annually/12,000 mi (19,308 km) (whichever occurs first)
- B-biennially/24,000 mi (38,616 km) (whichever occurs first)
- 3K-every 3,000 mi (4,827 km) (no calendar interval)
- 6K-every 6,000 mi (9,654 km) (no calendar interval)
- 12K-every 12,000 mi (19,308 km) (no calendar interval)
- 24K-every 24,000 mi (38,616 km) (no calendar interval)

H-2. OIL FILTERS

Oil filters shall be serviced/changed as applicable, when:

- a. They are known to be contaminated, or clogged;
- b. Service is recommended by AOAP laboratory analysis; or
- c. At prescribed hardtime intervals while vehicle is under warranty, or if AOAP is not available/used as required.

H-3. AOAP SAMPLING INTERVAL

WARNING

- **Engine oil is hot and under pressure. The oil sampling valve releases oil proportionally to the amount of pressure applied to valve. Activate oil sampling valve by pressing in slowly to prevent injury to personnel. Failure to comply may result in injury to personnel.**
- **Wear safety goggles when taking oil sample. Oil is under pressure and could cause injury to personnel. Failure to comply may result in injury to personnel.**

Engine/transmission oil must be sampled every 90 days as prescribed by DA Pam 738-750. Hydraulic fluids must be sampled annually as prescribed by DA Pam 738-750.

H-4. WARRANTY HARDTIME STATEMENT

"For equipment under manufacturer's warranty, hardtime oil service intervals shall be followed. Intervals shall be shortened if lubricants are known to be contaminated or if operation is under adverse conditions (such as longer than usual operating hours, extended idling periods, extreme dust)."

SECTION II. LUBRICATION CHART

H-5. LUBRICATION KEY

LUBRICANTS	
Specification	Type
MIL-L-2104 (OE/HDO)	Lubricating Oil, Internal Combustion Engine, Combat/Tactical Service
MIL-L-46167 (OEA)	Lubricating Oil, Internal Combustion Engine, Arctic
MIL-L-2105 (GO)	Lubricating Oil, Gear, Multipurpose
MIL-G-10924 (GAA)	Grease, Automotive and Artillery
MIL-G-18458 (GW)	Grease, Wire-Rope and Exposed Gear
MIL-H-5606 (OHA)	Hydraulic Fluid, Petroleum Base, Aircraft, Missile, and Ordnance

DESCRIPTION	CAPACITY	EXPECTED TEMPERATURES		
		Above +40°F (Above +4°C)	+40°F to -15°F (+4°C to -26°C)	-15°F to -50°F (-26°C to -46°C)
Engine crankcase	25 qt (24 L)	OE/HDO-15/40	OE/HDO-15/40	OEA
Transmission (total system) (all models except M1088 and M1089)	49.3 qt (46.7 L)	OE/HDO-15/40	OE/HDO-10	OEA
Transmission (at oil change) (all models except M1088 and M1089)	36.8 qt (34.7 L)	OE/HDO-15/40	OE/HDO-10	OEA
Transmission (total system) (M1088 and M1089)	58.6 qt (55.4 L)	OE/HDO-15/40	OE/HDO-10	OEA
Transmission (at oil change) (M1088 and M1089)	31.8 qt (30.0 L)	OE/HDO-15/40	OE/HDO-10	OEA
Transmission (after overhaul)	39.0 qt (37.0 L)	OE/HDO-15/40	OE/HDO-10	OEA
Steering system	5 qt (4.8 L)	OE/HDO-10	OE/HDO-10	OEA
Hydraulic reservoir (except M1089)	27 gal (102.2 L)	OE/HDO-10	OE/HDO-10	OEA
Hydraulic tank (M1089)	74 gal (280 L)	OE/HDO-10	OE/HDO-10	OEA
Front axle differential (maximum capacity)	9.5 qt (9 L)	GO-80/90	GO-80/90	SAE 75W90 OR GO-75
Intermediate axle differential (maximum capacity)	14.7 qt (13.9 L)	GO-80/90	GO-80/90	SAE 75W90 OR GO-75
Rear axle differential (maximum capacity)	12.15 qt (11.5 L)	GO-80/90	GO-80/90	SAE 75W90 OR GO-75
Front axle planetary hubs	11-13 oz (0.33-0.38 L)	GO-80/90	GO-80/90	SAE 75W90 OR GO-75

H-5. LUBRICATION KEY (CONT)

DESCRIPTION	CAPACITY	EXPECTED TEMPERATURES		
		Above +40°F (Above +4°C)	+40°F to -15°F (+4°C to -26°C)	-15°F to -50°F (-26°C to -46°C)
Rear axle bogie	0.5 qt (0.5 L)	GO-85/140	GO-85/140	GO-85/140
15K Self-Recovery Winch (SRW)	As Required	GO-85/140	GO-80/90	GO-75
30K winches	As Required	GO-85/140	GO-80/90	GO-75
Propeller shaft universal and slip joints	As Required	GAA	GAA	GAA
Tie rod ends	As Required	GAA	GAA	GAA
Towing pintle assembly	As Required	GAA	GAA	GAA
Fifth wheel	As Required	GAA	GAA	GAA
Spring bolts and spring shackles	As Required	GAA	GAA	GAA
Front axle shaft U-joints and steering knuckles	As Required	GAA	GAA	GAA
Front axle inner wheel bearing	As Required	GAA	GAA	GAA
Intermediate axle inner wheel bearing	As Required	GAA	GAA	GAA
Rear axle inner wheel bearing	As Required	GAA	GAA	GAA
Front lifting beam	As Required	GAA	GAA	GAA
15K Self-Recovery Winch (SRW) cable	As Required	GW	GW	GW
30K winch cables	As Required	GW	GW	GW
Air/hydraulic power unit	3 pt (1.4 L)	OHA	OHA	OHA
Backup hydraulic pump	19 oz (562 ml)	OHA	OHA	OHA

COOLANT	
Specification	Type
MIL-A-46153	Antifreeze, Ethylene Glycol, Inhibited, Heavy Duty, Single Package
MIL-A-11755	Antifreeze, Arctic-Type

DESCRIPTION	CAPACITY	EXPECTED TEMPERATURES		
		Above +40°F (Above +4°C)	+40°F to -15°F (+4°C to -26°C)	-15°F to -50°F (-26°C to -46°C)
Cooling system (engine only)	14 qt (13 L)	MIL-A-46153	MIL-A-46153	
Cooling system (total system)	50.3 qt (47.6 L)	MIL-A-46153	MIL-A-46153	N/A
Cooling system (total system) (M1088, M1089)	52.8 qt (49.9 L)	MIL-A-46153	MIL-A-46153	N/A
Cooling system, Arctic (total system)	64.8 qt (61.3 L)	N/A	N/A	MIL-A-11755
Cooling system, Arctic (total system) (M1088, M1089)	76.5 qt (72.4 L)	N/A	N/A	MIL-A-11755

CLEANING AGENT	
Specification	Type
P-D-680	Dry Cleaning Solvent, SD-II
O-C-1901	Cleaning Compound, Windshield

DESCRIPTION	CAPACITY	EXPECTED TEMPERATURES		
		Above +15°F (Above -9°C)	+15°F to -15°F (-9°C to -26°C)	-15°F to -50°F (-26°C to -46°C)
All metal parts as required	N/A	SD-II (all temperatures)		
Windshield washer reservoir	7.5 qt (7.1 L)	2/3 water to 1/3 O-C-1901	1/2 water to 1/2 O-C-1901	1/3 water to 2/3 O-C-1901

For arctic operation refer to FM 9-207.

H-6. LUBRICATION INTERVALS

Intervals		Total Man-Hours
Quarterly (Q)	Lubrication performed once every three months or 3,000 mi. (4,827 km).*	2.0
Semi-annually (S)	Lubrication performed once every six months or 6,000 mi. (9,654 km).*	6.0
Annually (A)	Lubrication performed once every year or every 12,000 mi. (19,308 km).*	1.5
Biennially (B)	Lubrication performed once every two years or every 24,000 mi. (38,616 km).*	3.5
3K	Lubrication performed once every 3,000 mi. (4,827 km).**	1.0
6K	Lubrication performed once every 6,000 mi. (9,654 km).**	1.0
12K	Lubrication performed once every 12,000 mi. (19,308 km).**	6.5
24K	Lubrication performed once every 24,000 mi. (38,616 km).**	0.5
* Whichever occurs first.		
** No calendar interval.		

H-7. LUBRICATION LOCATOR VIEWS

LUBRICANT INTERVAL

INTERVAL LUBRICANT

Engine Crankcase Breather (O)
(See note 17 and view A)

Fuel Filter (O)
(See note 6 and view A)

Fuel/Water Separator (O)
(See note 5 and view B)

Cooling System (O)
(See note 7)

Transmission Filter (O)
(See note 3 and view F)

Transmission Drain and Fill (O)
(See note 3 and views D, E, and F)

Intermediate Axle and Rear Axle Inner Wheel Bearing Repack (O)
(See note 27)

Towing Pintle Fill (O)
(See note 16 and views J and K)

Engine Oil Filter (O)
(See note 2 and view C)

Crankcase Drain and Fill (O)
(See note 1 and views C and D)

Front Axle Inner Wheel Bearing Repack (O)
(See note 27)

Power Steering Reservoir Drain and Fill (O)
(See note 4 and view G)

Power Steering Filter (O)
(See note 4 and view G)

Rear Axle Bogie Drain and Fill (O)
(See note 28 and view AG)

15K Self-Recovery Winch (SRW) Cable Rear Roller Fairlead Fill (O)
(See note 29 and views AE and AF)

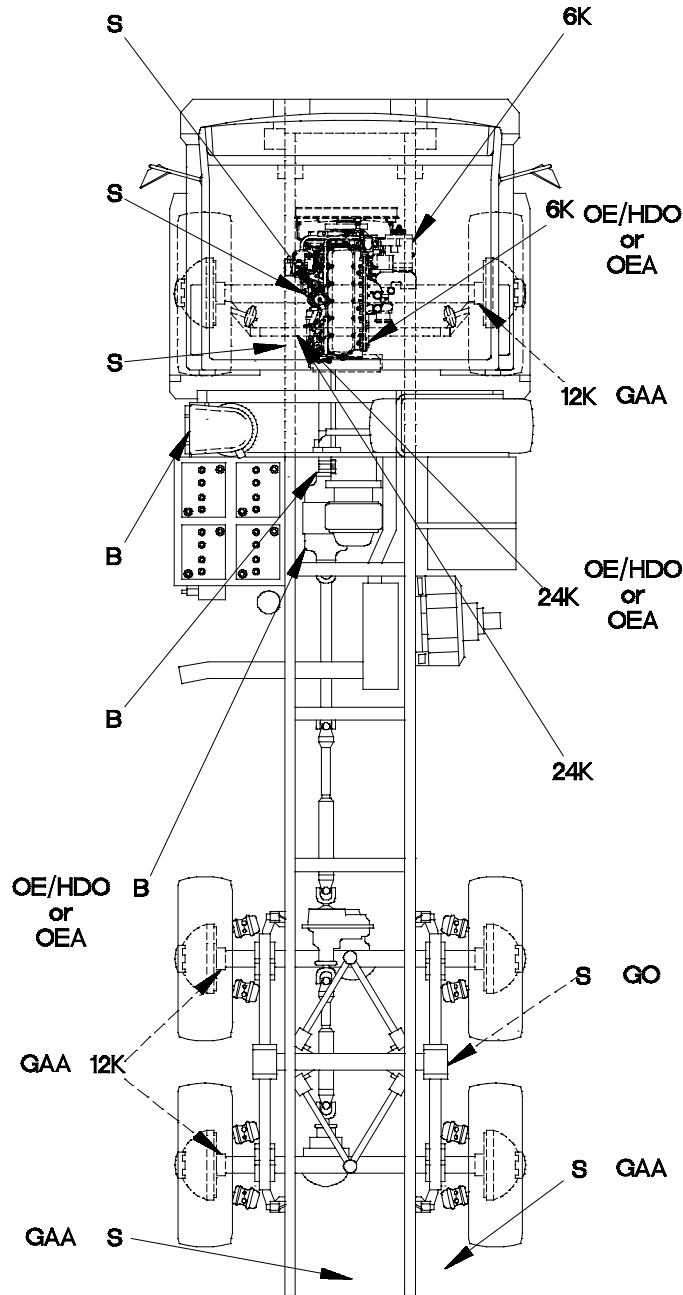

CHASSIS

NOTE: Dashed arrows indicate lubrication on both sides of vehicle.

LUBRICANT INTERVAL

INTERVAL LUBRICANT

**Spring Shackle
Fill (O)**
(See note 18 and view I)

**Tie Rod Ends
Fill (O)**
(See note 13 and view N)

**Universal and Slip Joints
Fill (O)**
(See note 9 and view P)

Battery Posts (O)
(See note 19 and view Q)

Air Dryer (O)
(See note 37 and view BB)

**Universal and Slip Joints
Fill (O)**
(See note 9 and view P)

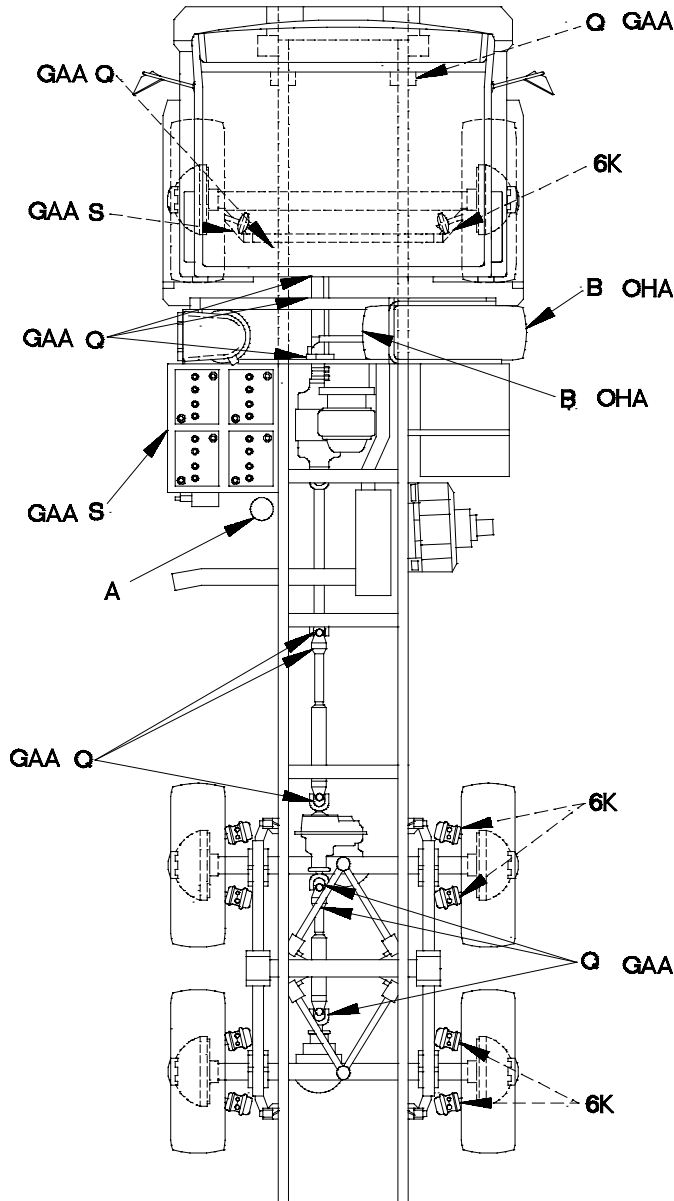

**Spring Bolt
Fill (O)**
(See note 18 and view H)

**Brake Wedge and Air
Chamber (O)**
(See note 21 and view L)

**Backup Hydraulic Pump
Drain and Fill (O)**
(See note 10 and view R)

**Air/Hydraulic Power Unit
Drain and Fill (O)**
(See note 10 and view S)

**Brake Wedge and Air
Chamber (O)**
(See note 21 and view M)

**Universal Joint and Slip
Joints
Fill (O)**
(See note 9 and view P)

**Brake Wedge and Air
Chamber (O)**
(See note 21 and view M)

CHASSIS

4APPH0E

NOTE: Dashed arrows indicate lubrication on both sides of vehicle.

H-7. LUBRICATION LOCATOR VIEWS (CONT)

LUBRICANT INTERVAL

INTERVAL LUBRICANT

**Front Axle
Check and Fill (O)**
(See note 11 and view T)

**Axle Shaft U-Joints
Fill (O)**
(See note 20 and view U)

**Steering Knuckles
Fill (O)**
(See note 20 and view U)

**Front Lifting Beam
Clean and Grease (O)**
(See note 36 and view AI)

**Hydraulic Reservoir and
Filter
Drain and Fill (O)**
(See note 8 and view X)

**Intermediate Axle Screen
and Plug Oil Filter
Assembly
Clean (O)**
(See note 31 and view AH)

**Intermediate Axle
Check and Fill (O)**
(See note 11 and view T)

**Rear Axle
Check and Fill (O)**
(See note 11 and view T)

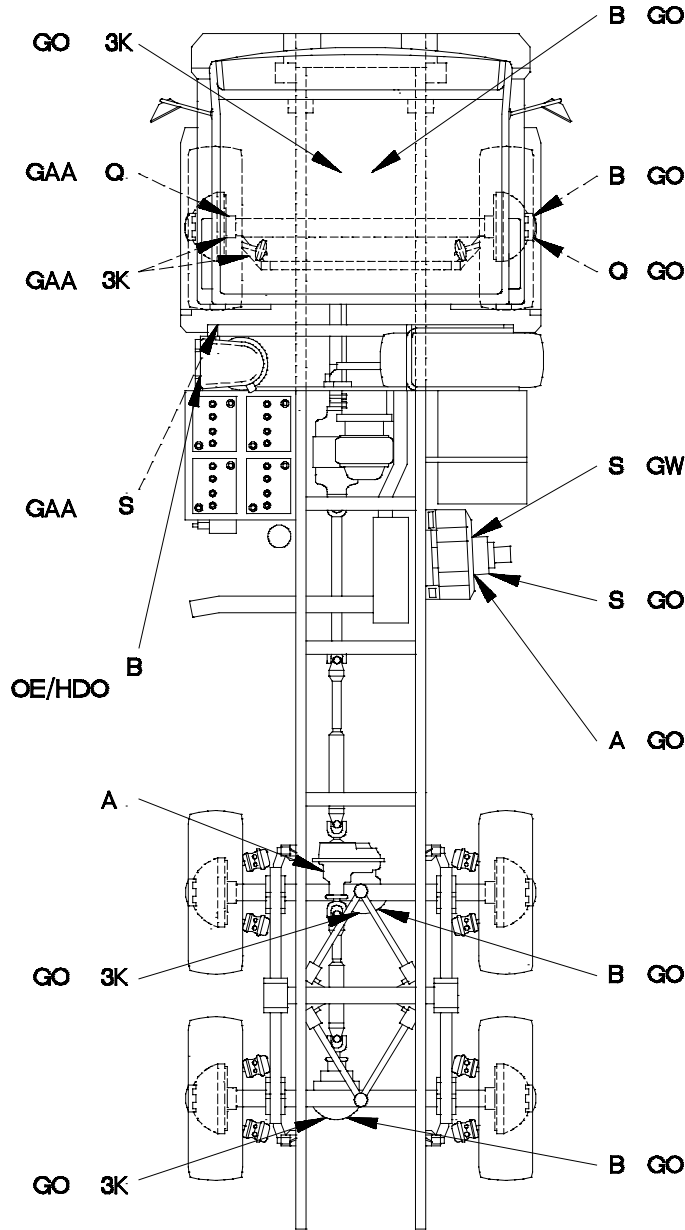

**Front Axle
Drain and Fill (O)**
(See note 11 and view T)

**Wheel End Planetary Hubs
Drain and Fill (O)**
(See note 12 and view V)

**Wheel End Planetary Hubs
Check and Fill (O)**
(See note 12 and view V)

**15K Self-Recovery Winch
(SRW) Cable
Fill (O)**
(See note 14 and view W)

**15K Self-Recovery Winch
(SRW)
Check and Fill (O)**
(See note 15 and view Y)

**15K Self-Recovery Winch
(SRW)
Drain and Fill (O)**
(See note 15 and view Y)

**Intermediate Axle
Drain and Fill (O)**
(See note 11 and view T)

**Rear Axle
Drain and Fill (O)**
(See note 11 and view T)

4APPH03B

CHASSIS

NOTE: Dashed arrows indicate lubrication on both sides of vehicle.

LUBRICANT INTERVAL

INTERVAL LUBRICANT

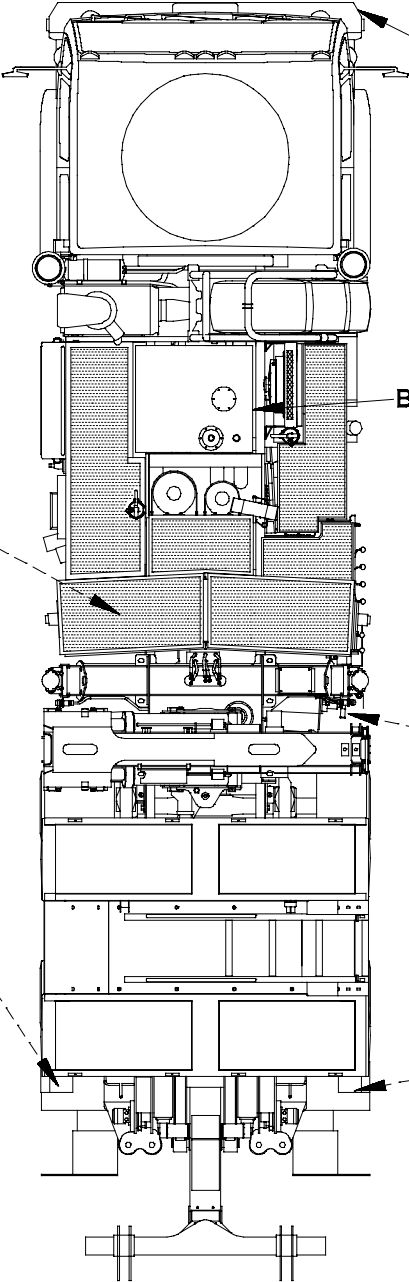

15K Self-Recovery Winch (SRW) Cable Front Roller Fairlead
Fill (O)
 (See note 29 and views Z and AA)

Hydraulic Tank and Filter Drain and Fill (O)
 (See note 22 and view AD)

30K Winch Cable Guide Rollers
Fill (O)
 (See note 30 and view AB)

30K Winch Cable Guide Rollers
Fill (O)
 (See note 30 and view AC)

30K Winch Cable
Fill (O)
 (See note 14 and view AB)

Pay-Out Assembly Lower Tension Sheave
Fill (O)
 (See note 30 and view BA)

4APPHQ4A

M1089

NOTE: Dashed arrows indicate lubrication on both sides of vehicle.

H-7. LUBRICATION LOCATOR VIEWS (CONT)

LUBRICANT INTERVAL

INTERVAL LUBRICANT

Erection Cylinder and Tension Link Pivots
Fill (O)
 (See note 34 and view AL)

Lift Cylinder Pivots
Fill (O)
 (See note 34 and view AJ)

Erection Cylinder Pivots
Fill (O)
 (See note 34 and view AK)

Tension Link Pivots
Fill
 (See note 34 and view AL)

Tension Links Grease (O)
 (See note 38 and view BC)

Turntable Bearing
Fill (O)
 (See note 32 and view AP)

Turntable Gearbox
Check and Fill (O)
 (See note 25 and view AQ)

Hoist Cable
Fill (O)
 (See note 14)

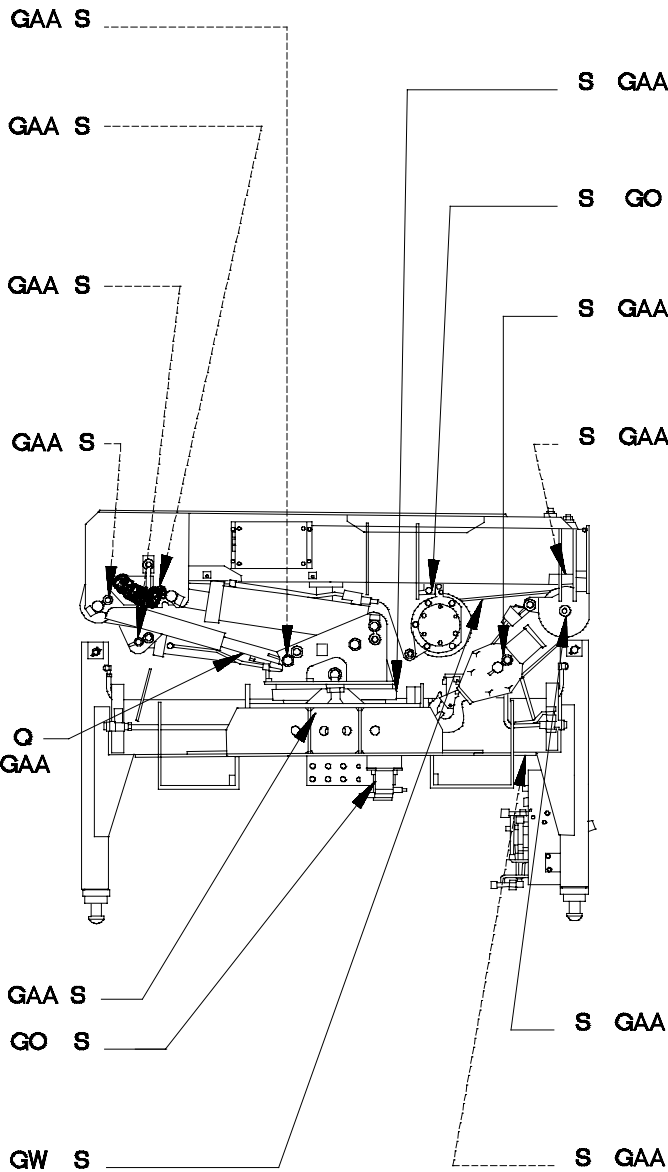

Turntable Bearing and Pinion Gear Teeth
Fill (O)
 (See note 26 and view AM)

Hoist
Check and Fill (O)
 (See note 24 and view AN)

Hook Block Sheave
Fill (O)
 (See note 34 and view AO)

Boom Wear Pads
Fill (O)
 (See note 23)

Boom Sheave
Fill (O)
 (See note 34 and view AR)

Top and Bottom Plate
Fill (O)
 (See note 33)

4APPH05B

M1089 MATERIAL HANDLING CRANE (MHC)

NOTE: Dashed arrows indicate lubrication on both sides of vehicle.

LUBRICANT INTERVAL

INTERVAL LUBRICANT

**Hoist
Check and Fill (O)**
(See note 24 and view AS)

**Boom Wear Pads
Fill (O)**
(See note 23)

**Boom Sheave
Fill (O)**
(See note 34 and view AT)

**Hoist Cable
Fill (O)**
(See note 14)

**Turntable Gearbox
Check and Fill (O)**
(See note 25 and view AU)

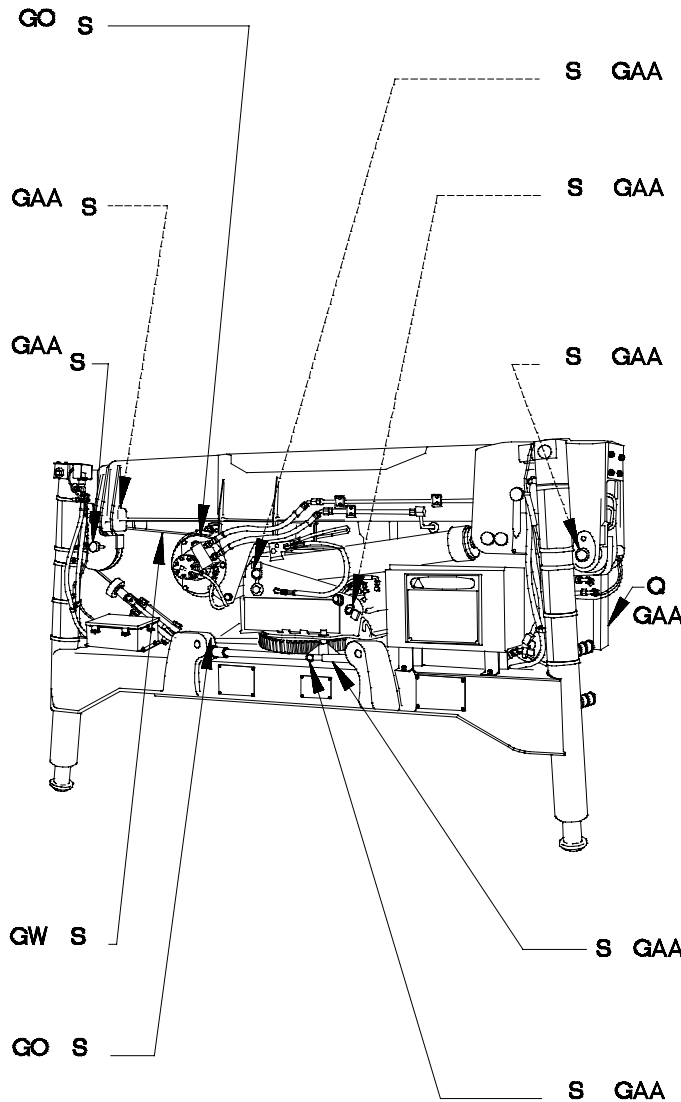

**Lift Cylinder Pivots
Fill (O)**
(See note 34 and view AV)

**Erection Cylinder and
Tension Link Pivots
Fill (O)**
(See note 34 and view AW)

**Erection Cylinder and
Tension Link Pivots
Fill (O)**
(See note 34 and view AX)

**Tension Link
Grease (O)**
(See note 38 and view BC)

**Turntable Bearing and
Pinion Gear Teeth
Fill (O)**
(See note 26 and view AY)

**Turntable Bearing
Fill (O)**
(See note 32 and view AZ)

4APPH06B

M1084/M1086 MATERIAL HANDLING CRANE (MHC)

NOTE: Dashed arrows indicate lubrication on both sides of vehicle.

H-7. LUBRICATION LOCATOR VIEWS (CONT)

LUBRICANT INTERVAL

INTERVAL LUBRICANT

Left and Right Lift Cylinder Pivots
Fill (O)
(See note 35)

Left and Right Lower Arm Pivots
Fill (O)
(See note 35)

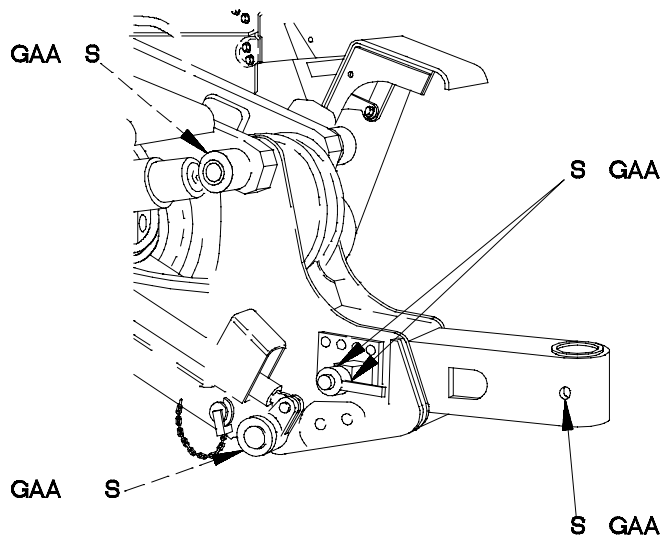

Camlock Assembly
Fill (O)
(See note 35)

Crossbar Bushing
Fill (O)
(See note 35)

4APPH07A

M1089 UNDERLIFT ASSEMBLY

NOTE: Dashed arrows indicate lubrication on both sides of vehicle.

H-8. LUBRICATION LOCAL VIEWS

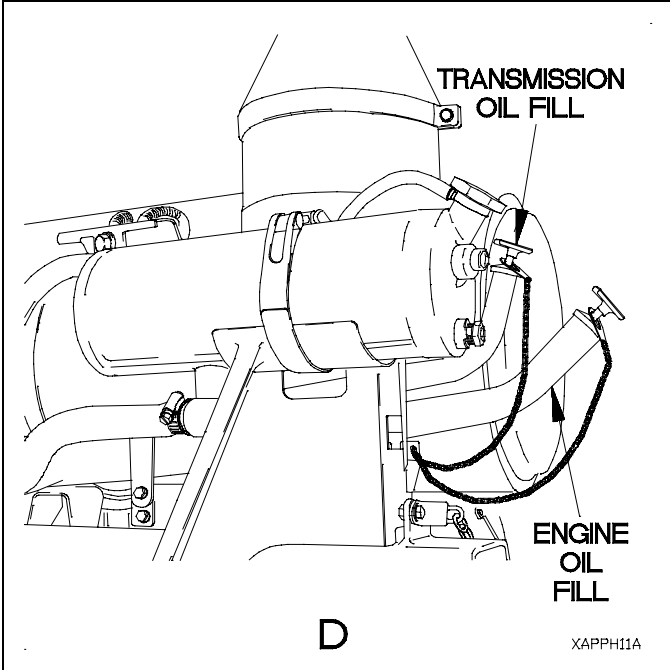
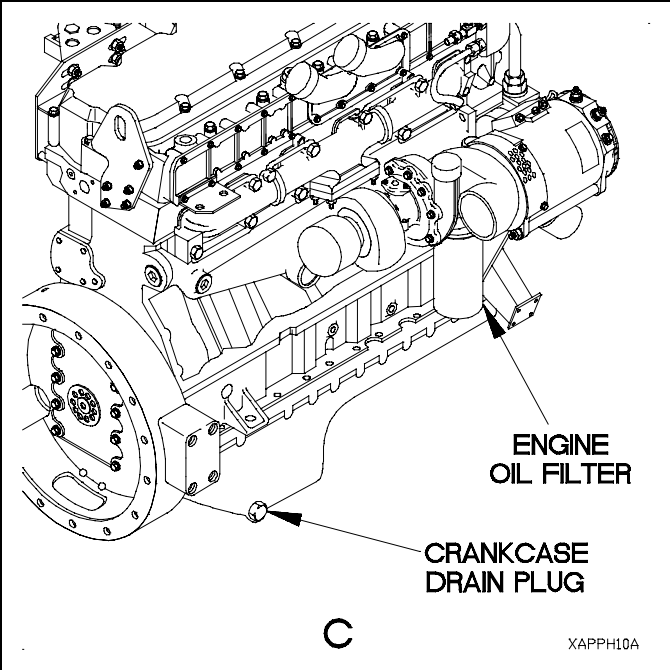
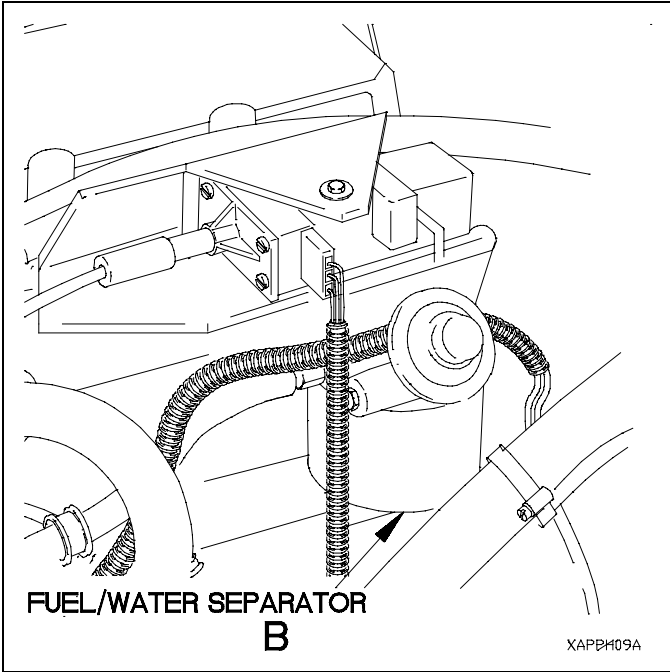
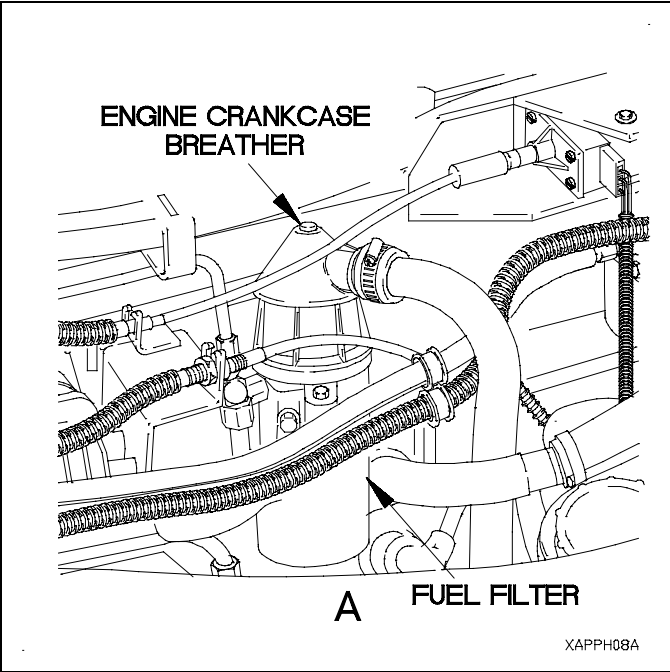

H-8. LUBRICATION LOCAL VIEWS (CONT)

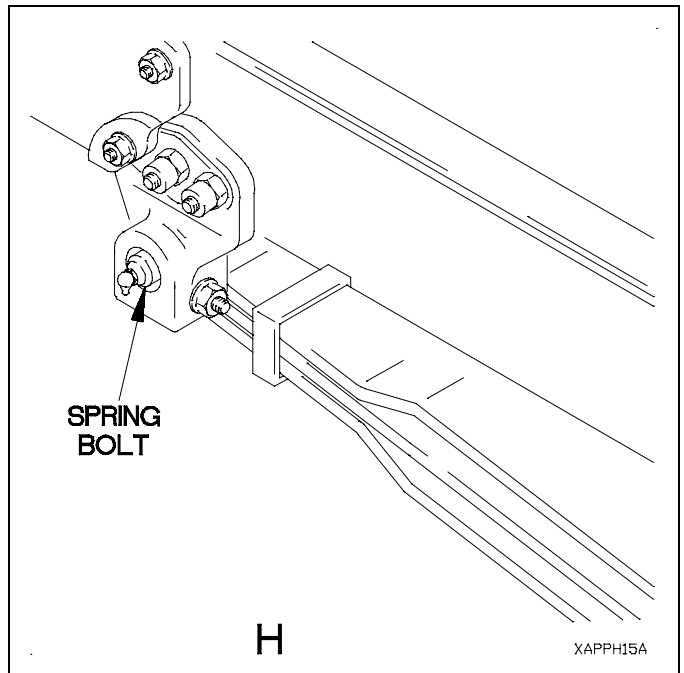
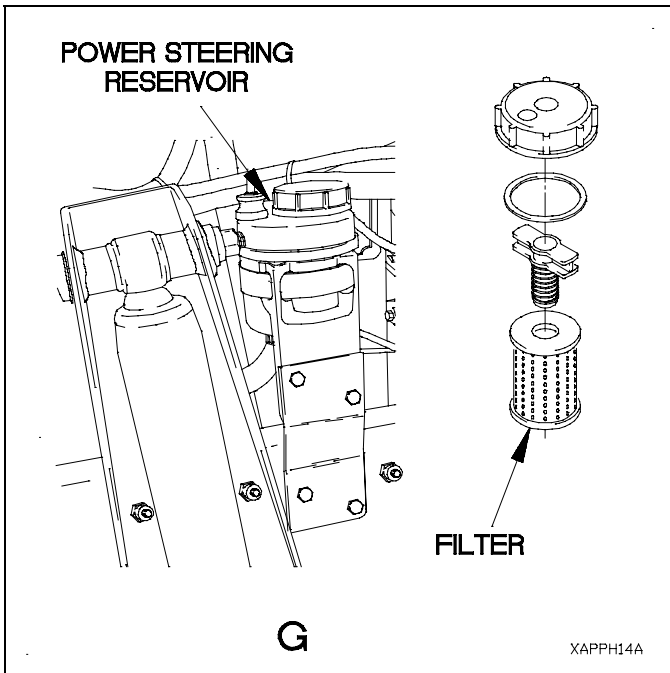
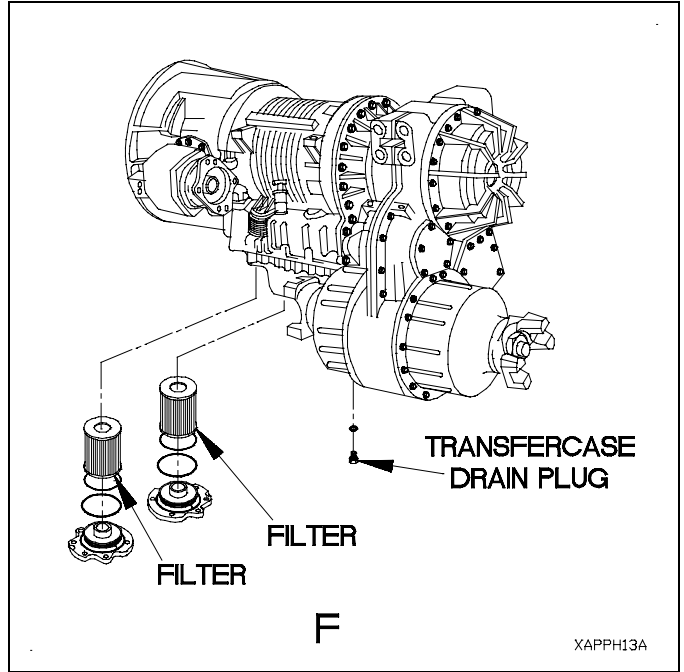
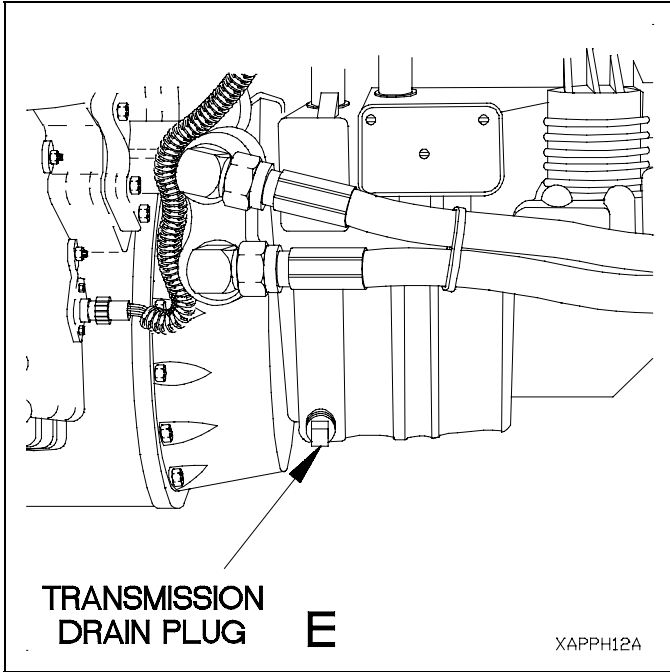

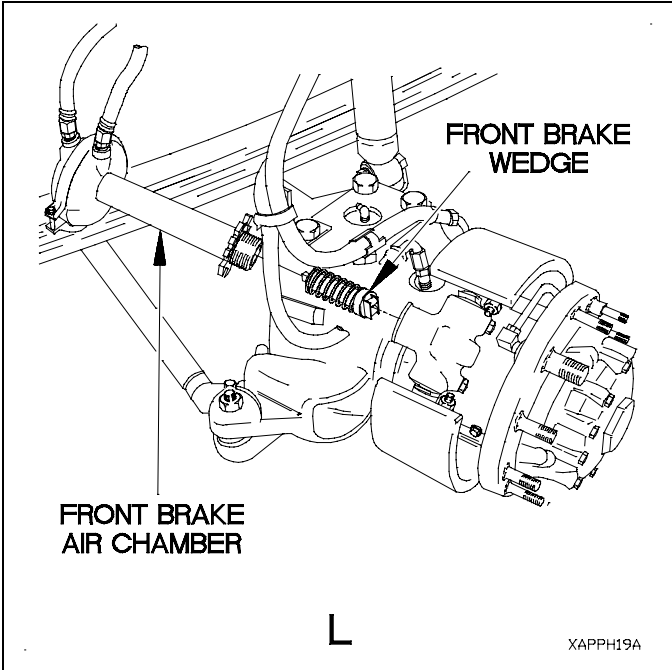
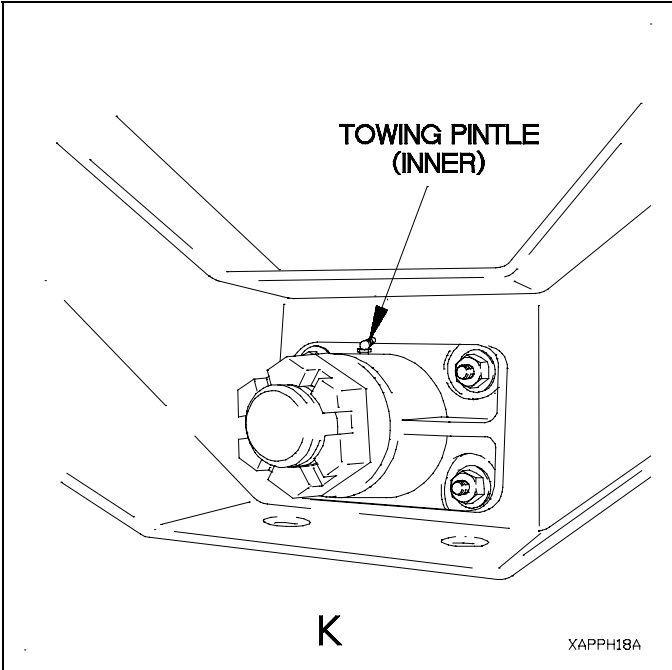
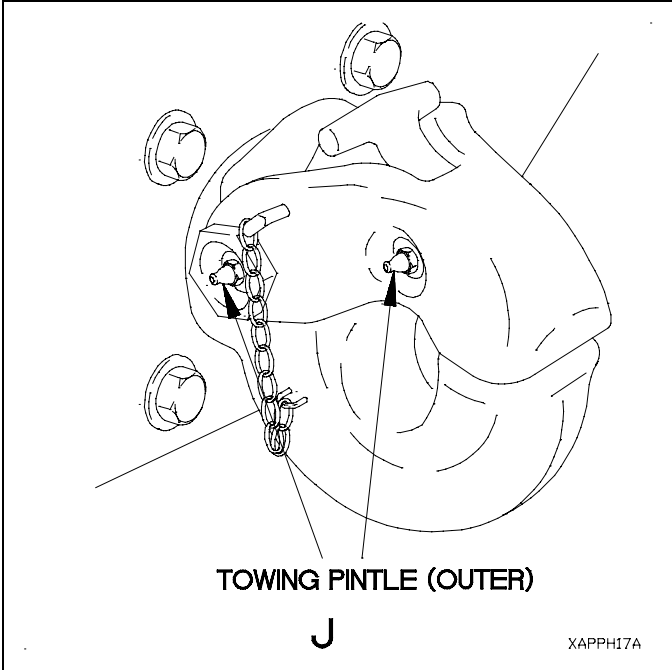
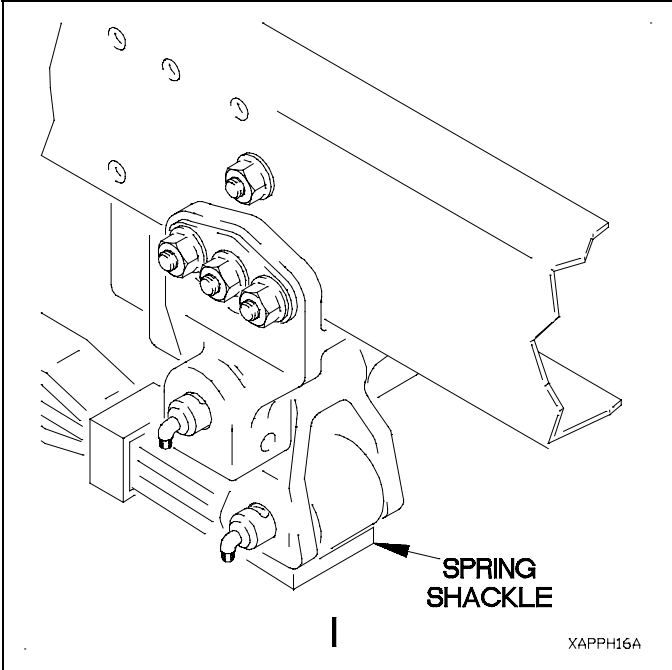

H-8. LUBRICATION LOCAL VIEWS (CONT)

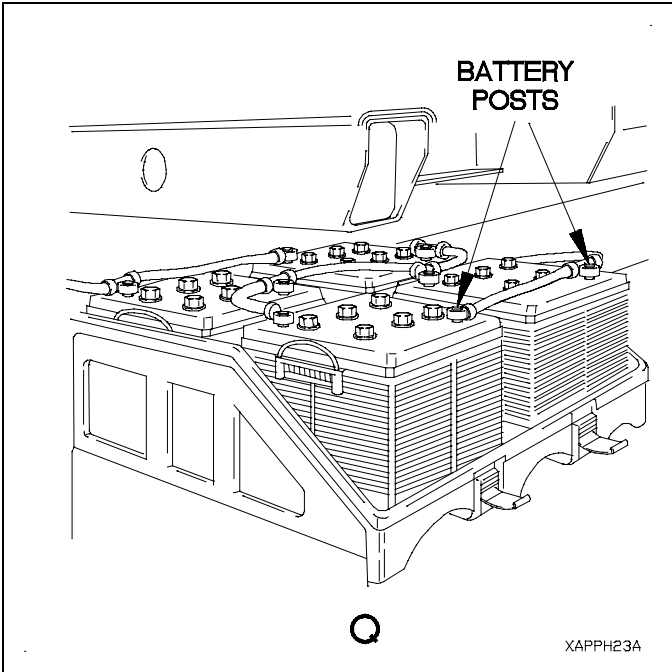
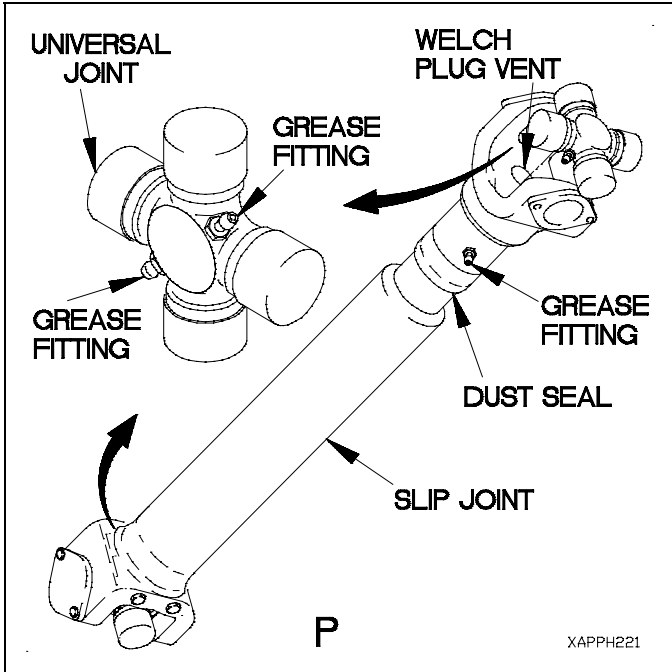
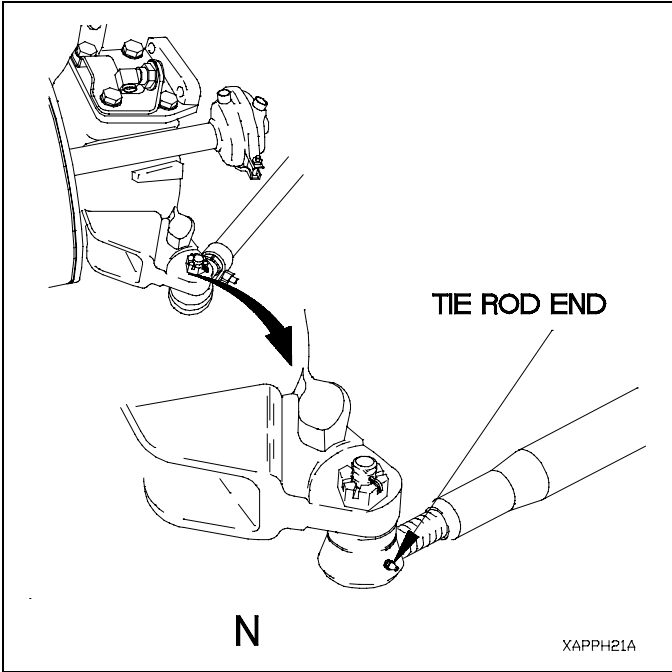
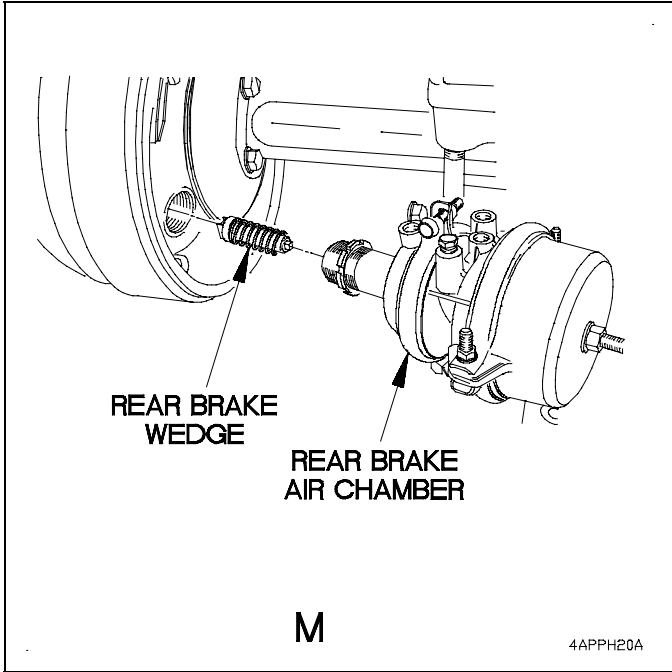

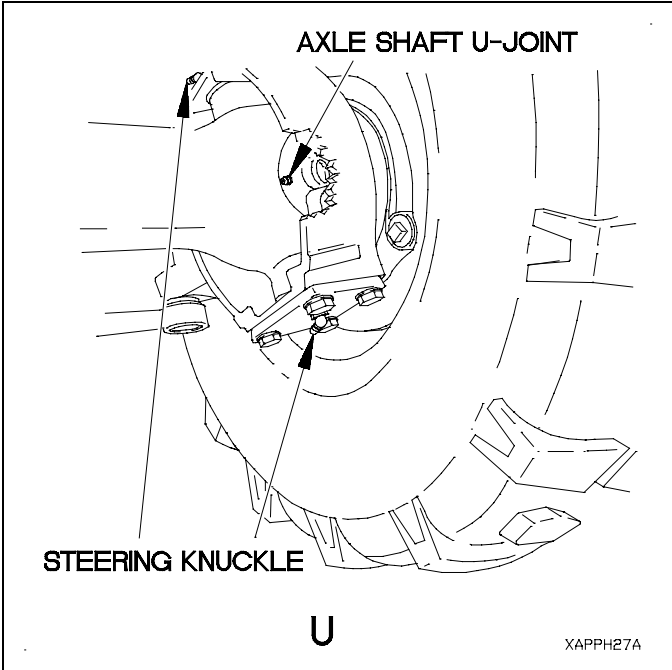
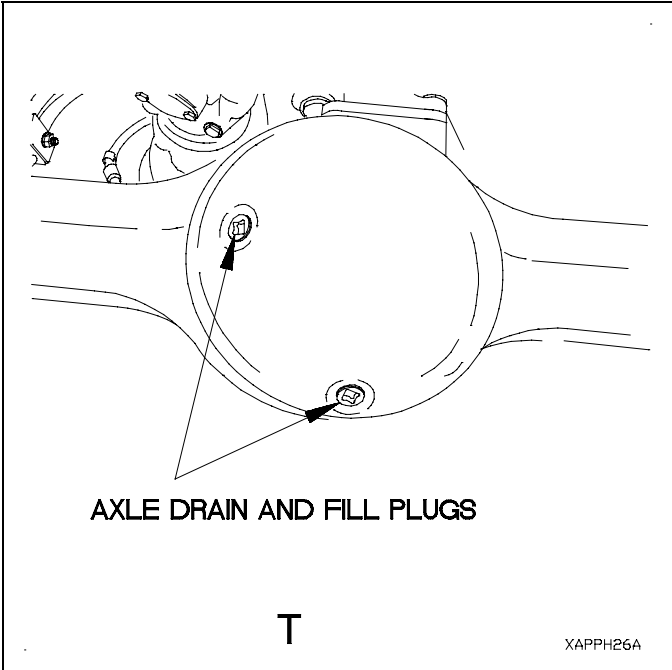
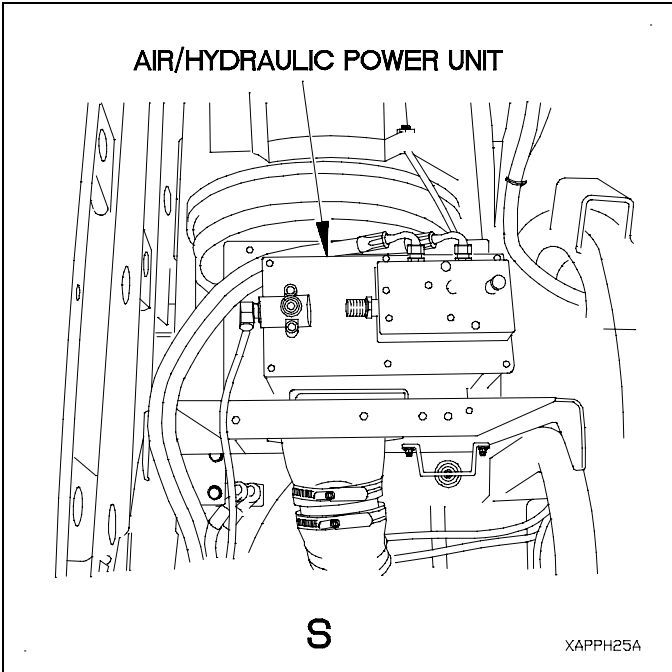
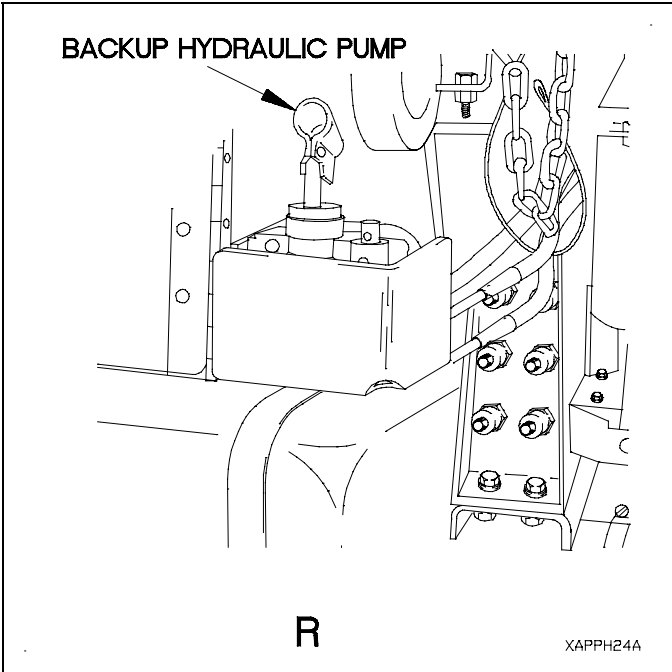

H-8. LUBRICATION LOCAL VIEWS (CONT)

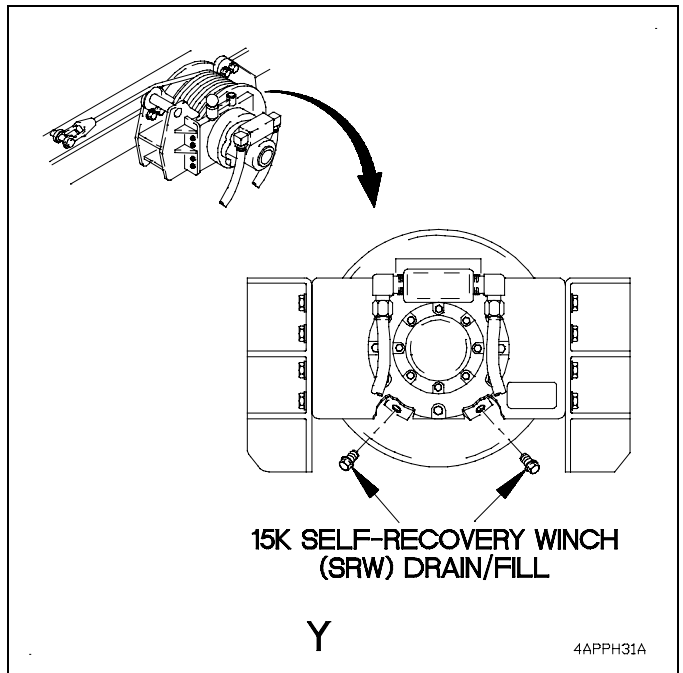
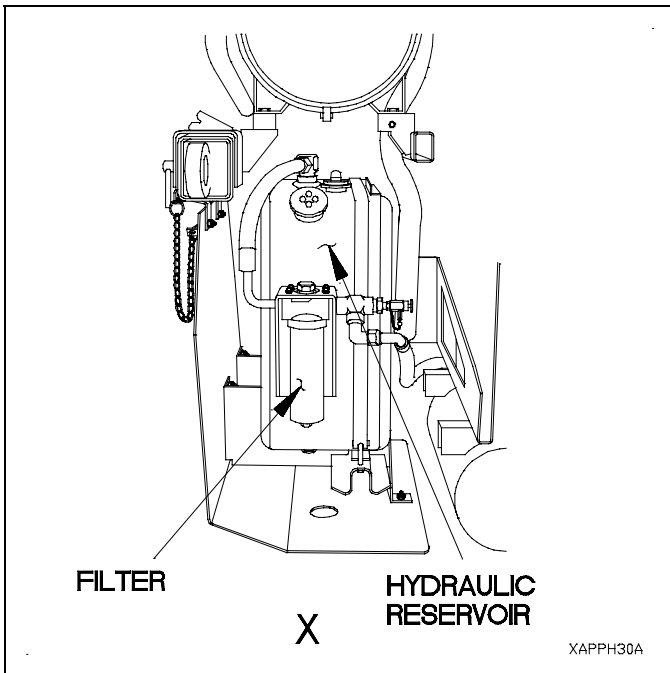
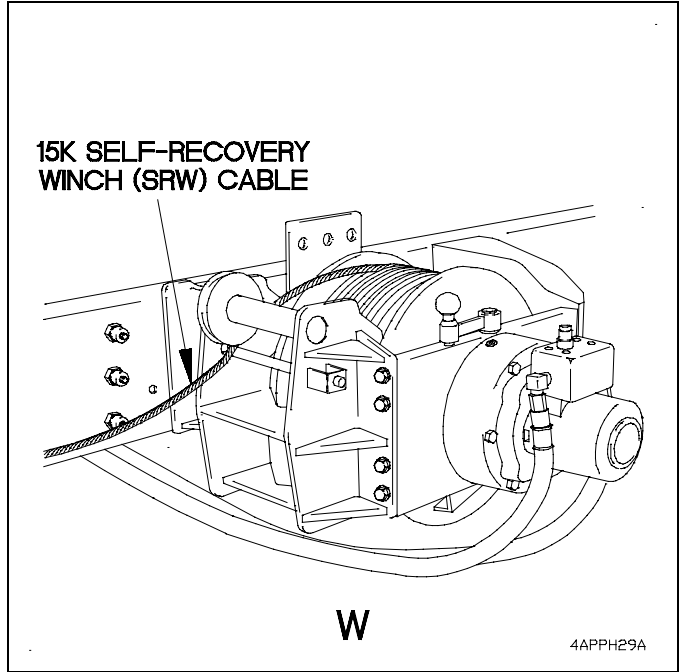
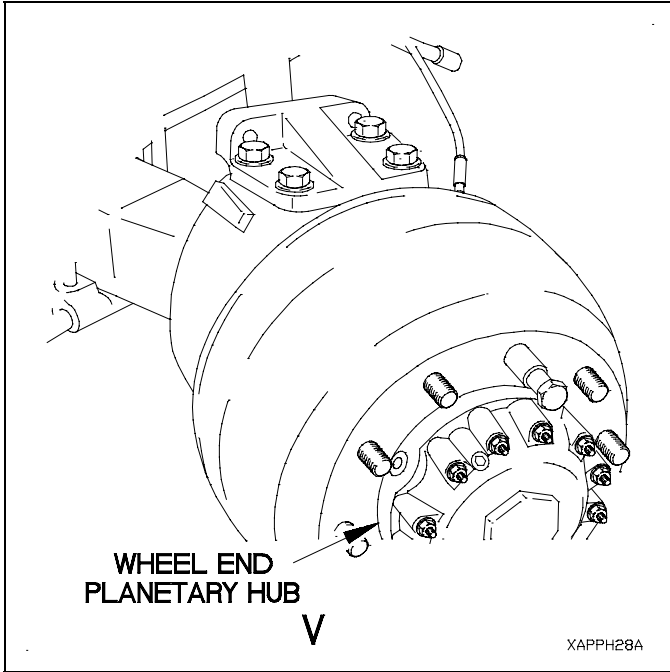

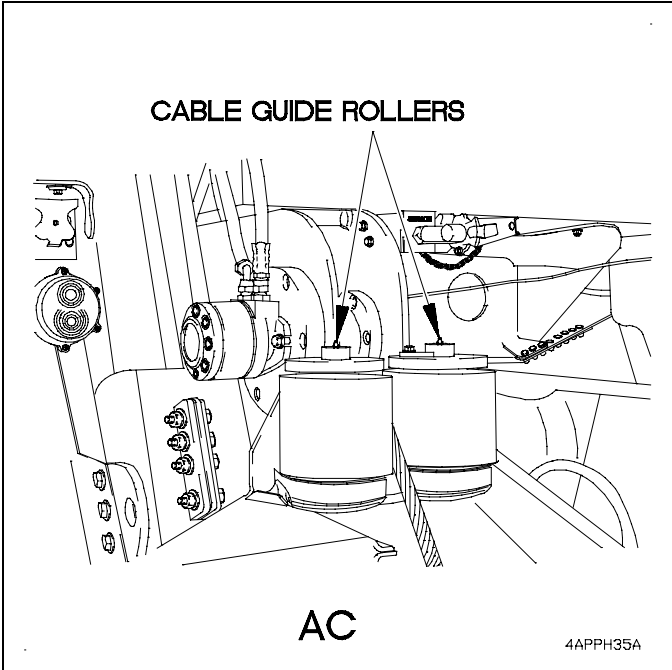
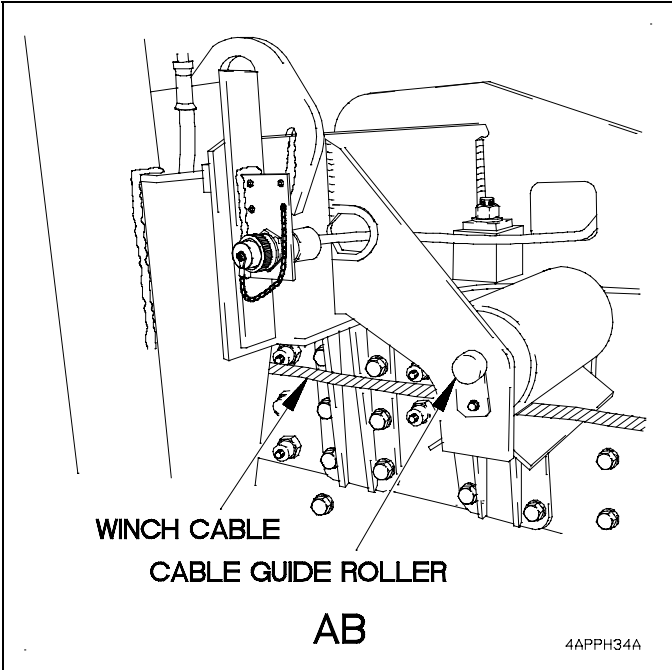
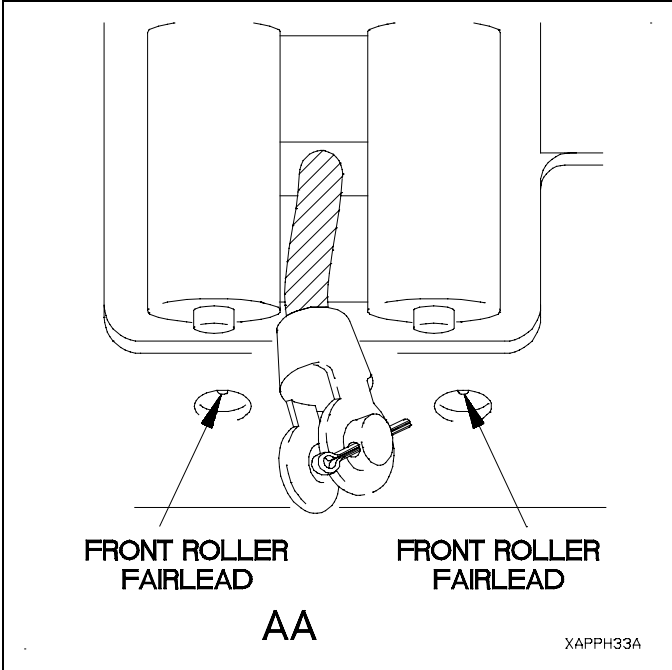
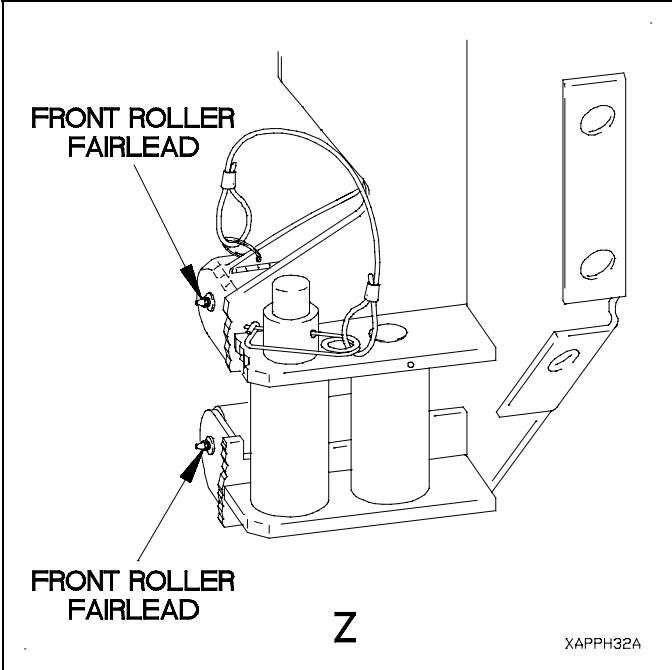

H-8. LUBRICATION LOCAL VIEWS (CONT)

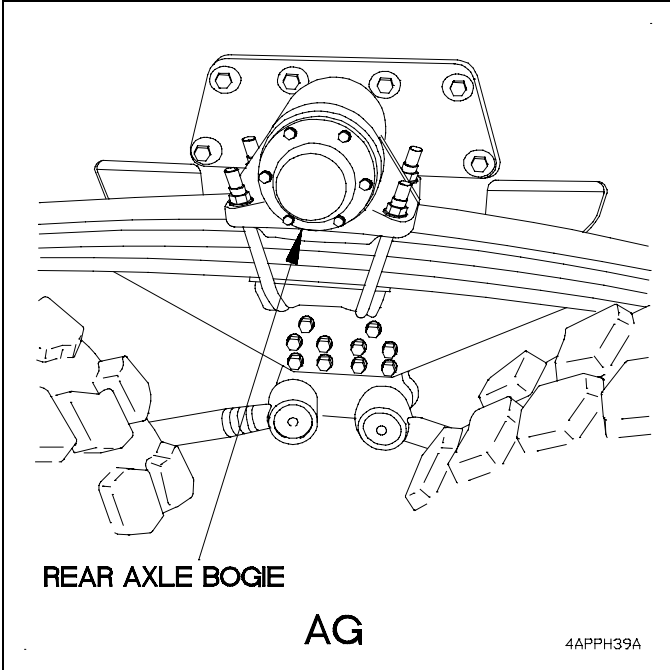
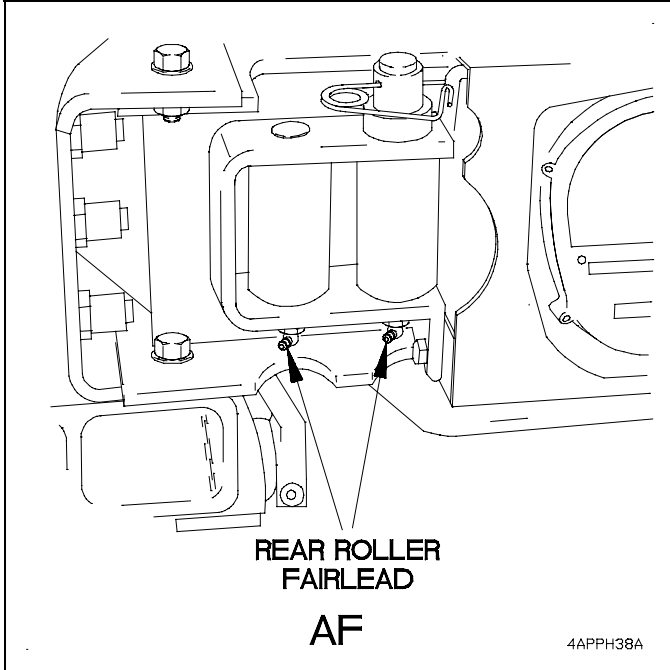
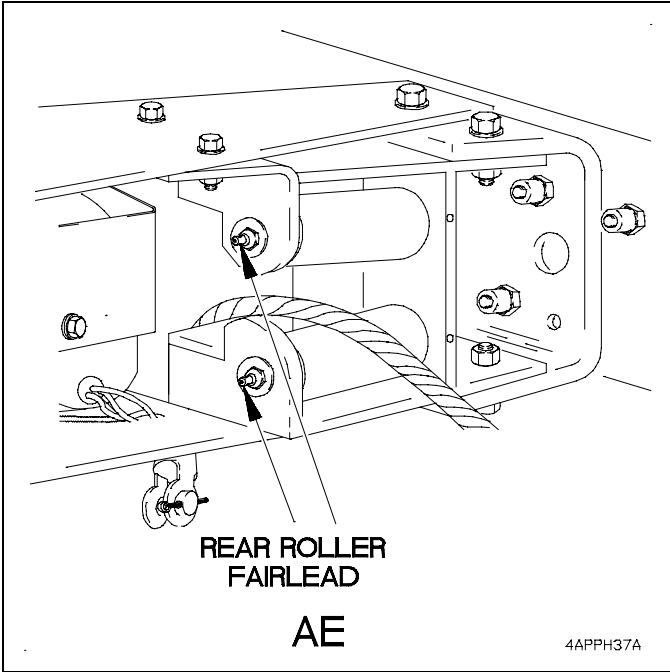
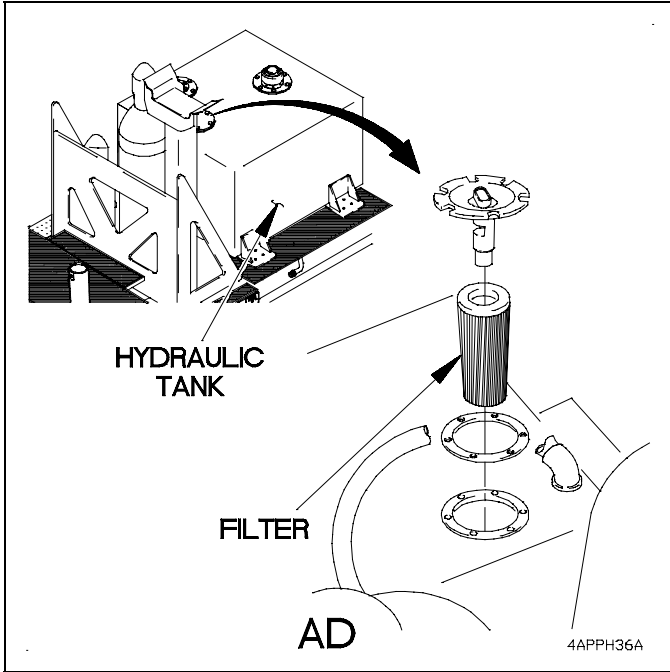

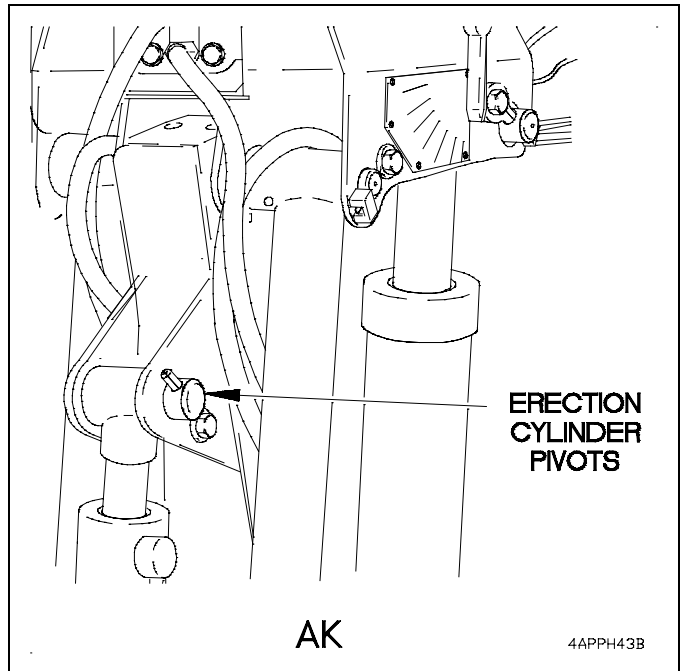
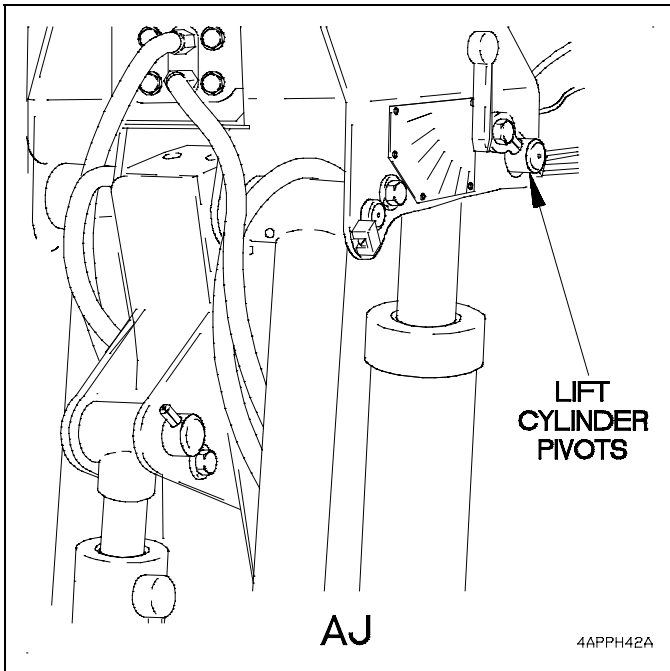
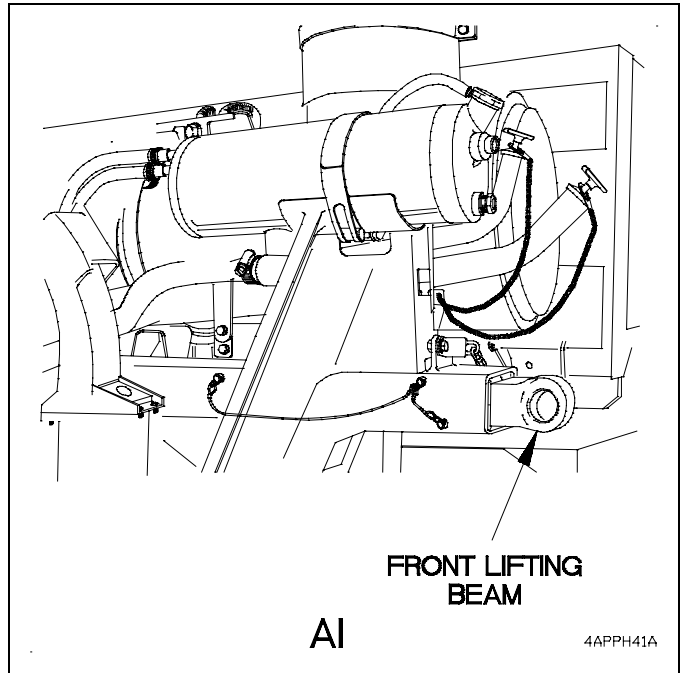
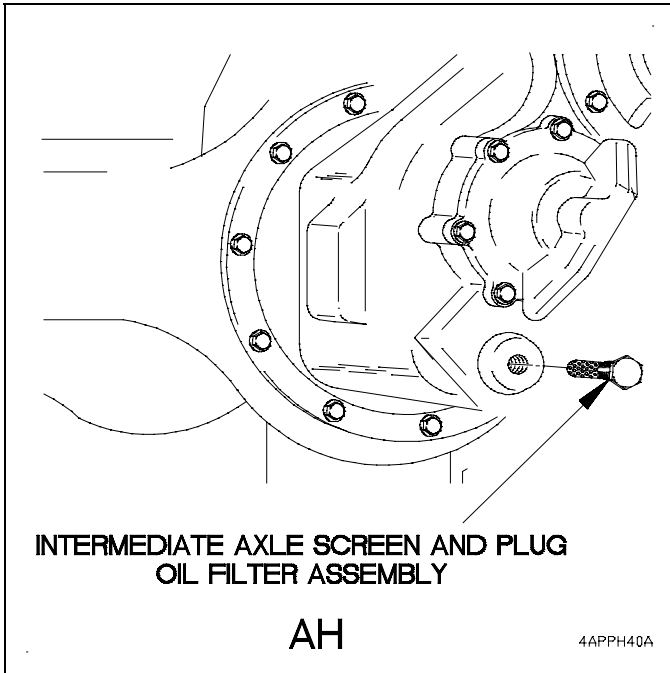

H-8. LUBRICATION LOCAL VIEWS (CONT)

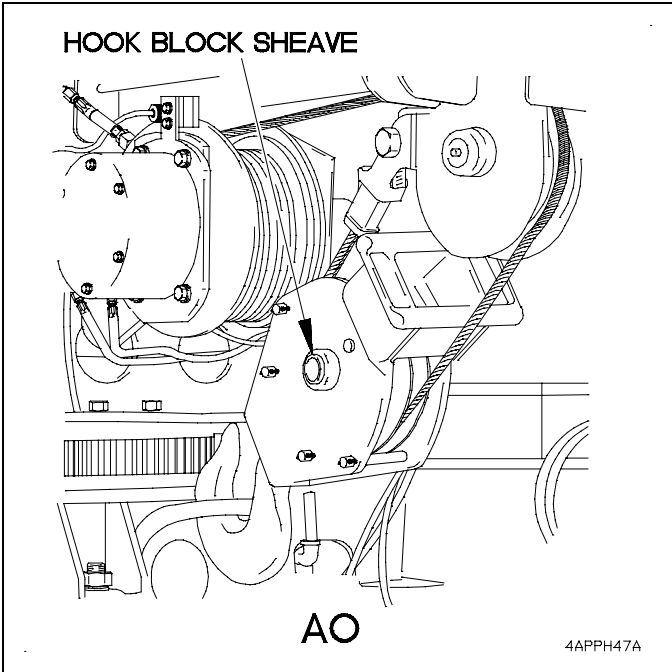
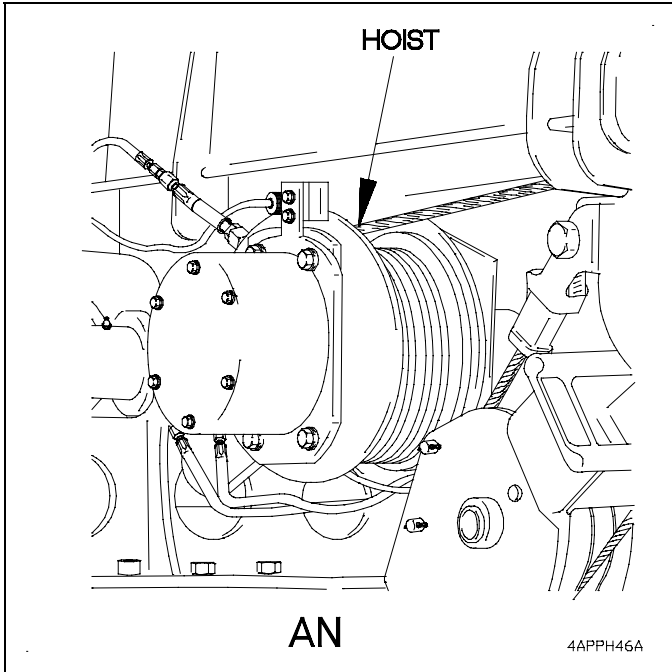
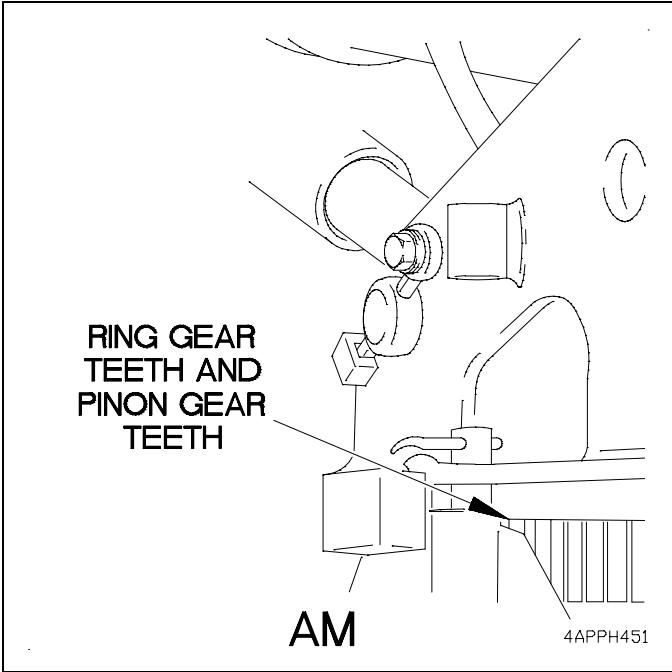
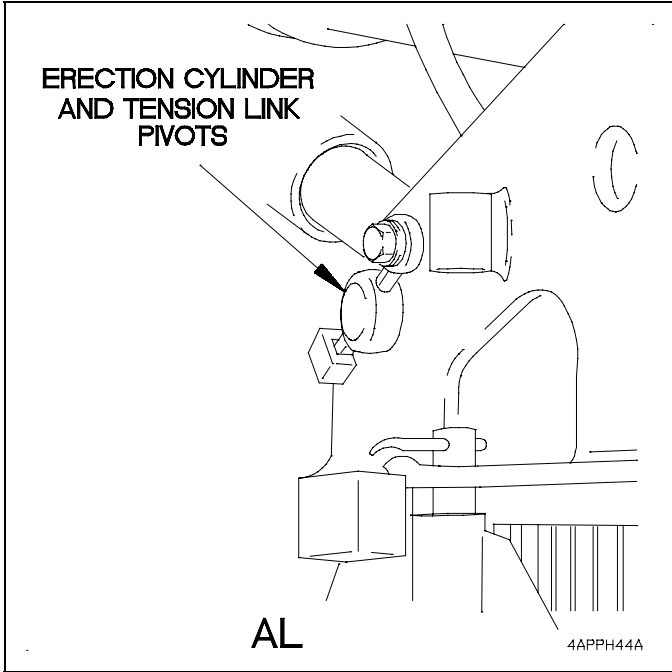

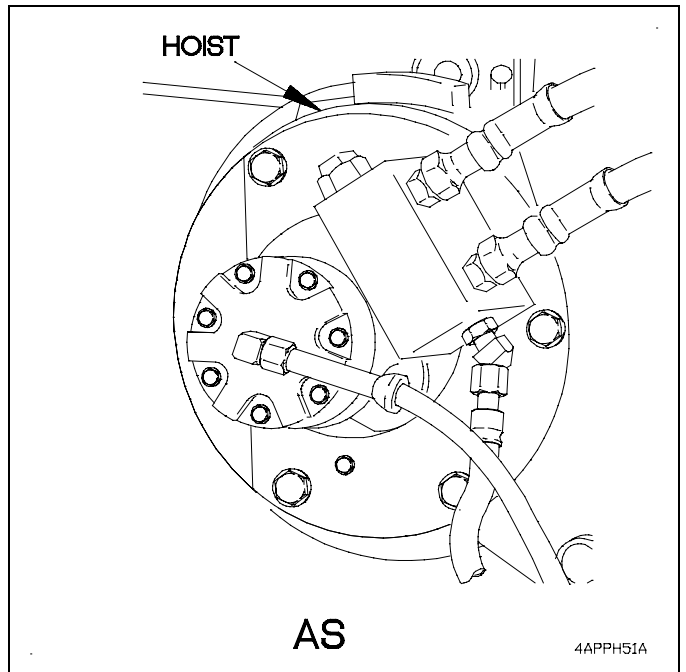
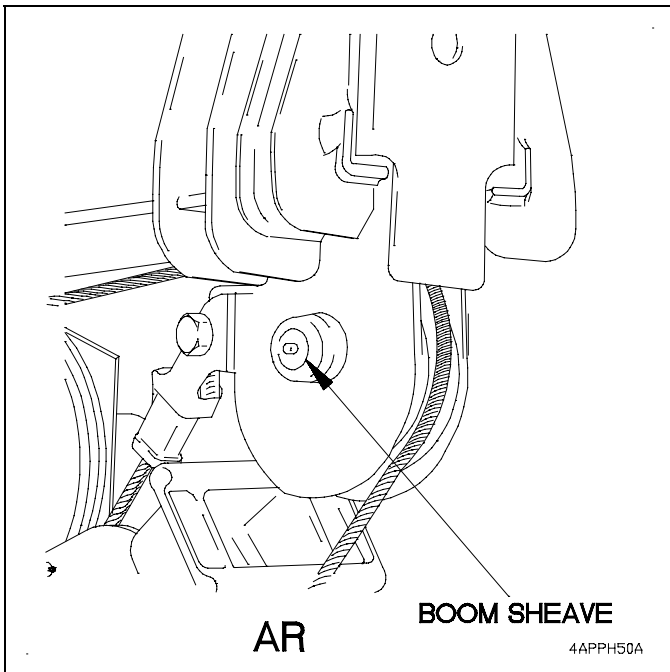
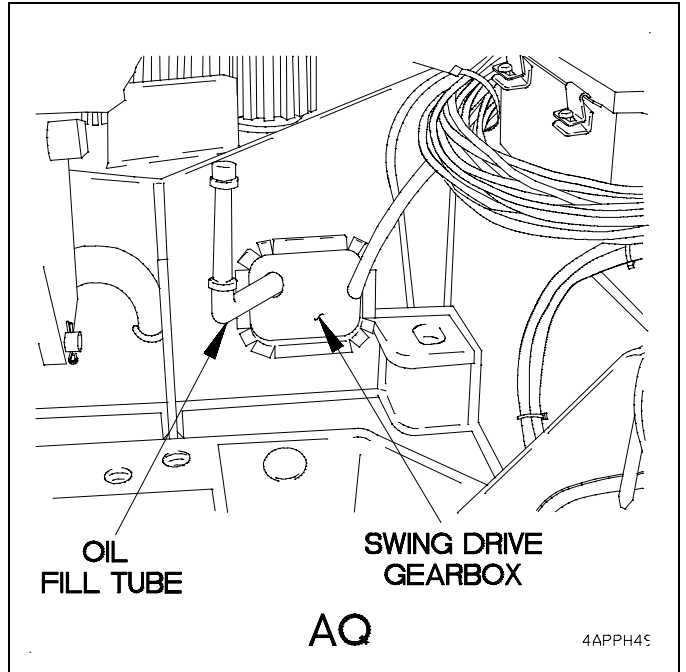
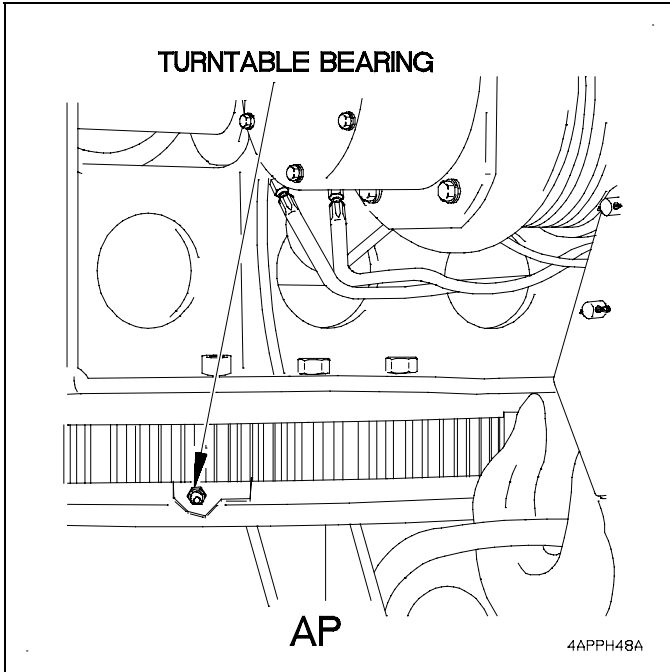

H-8. LUBRICATION LOCAL VIEWS (CONT)

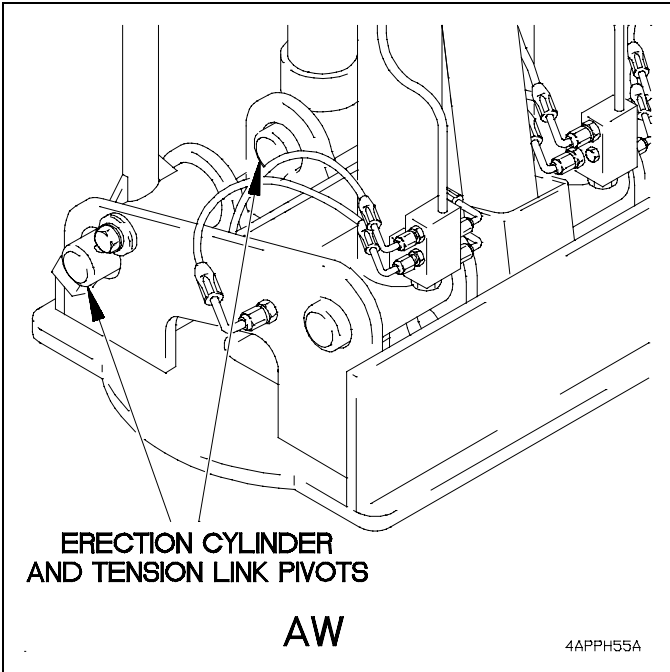
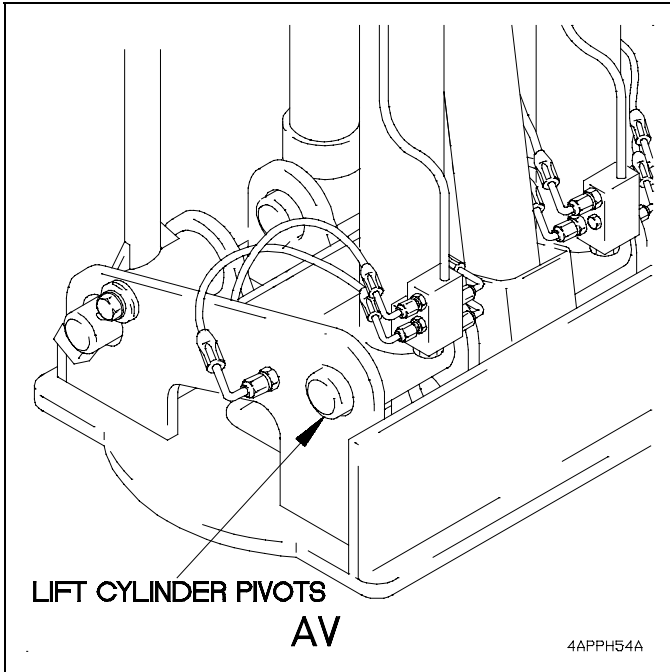
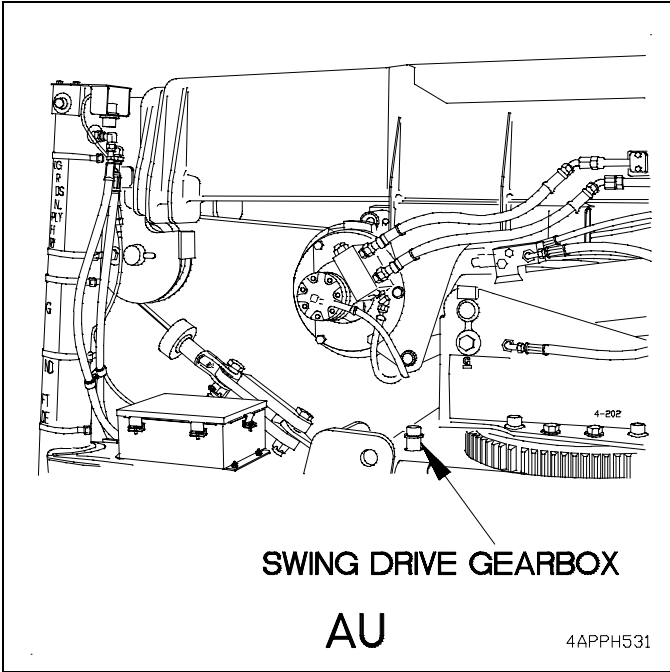
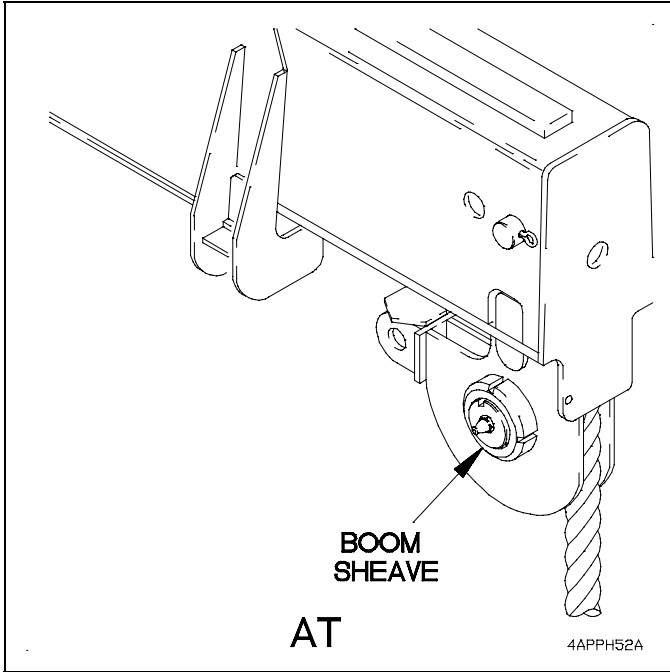

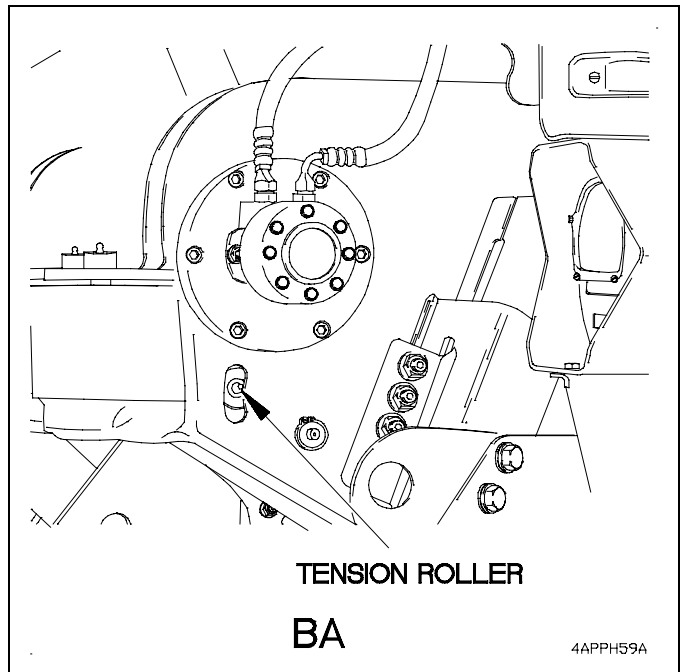
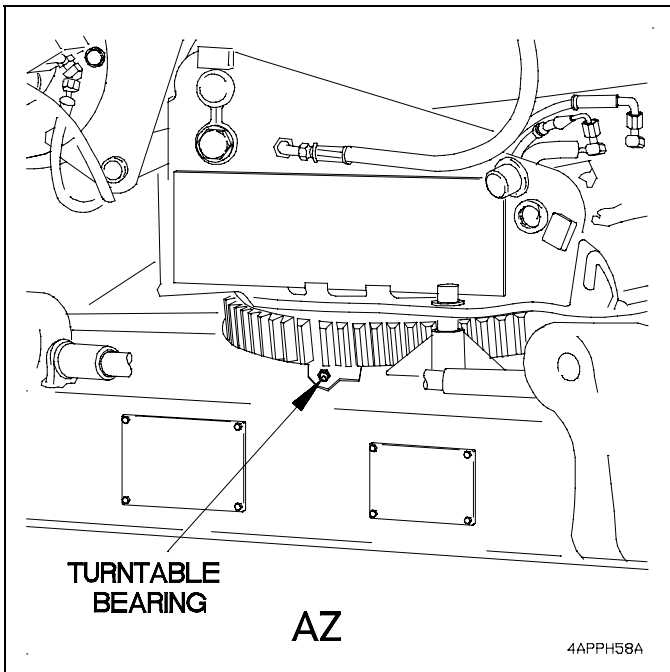
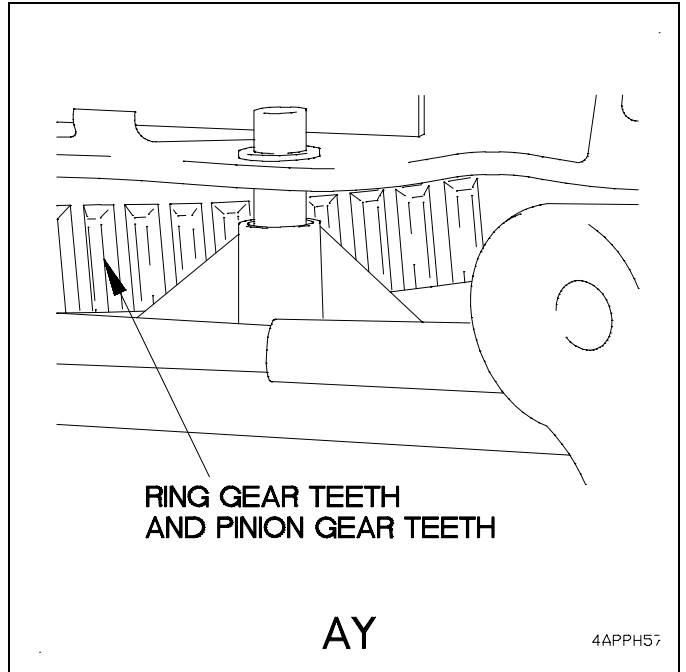
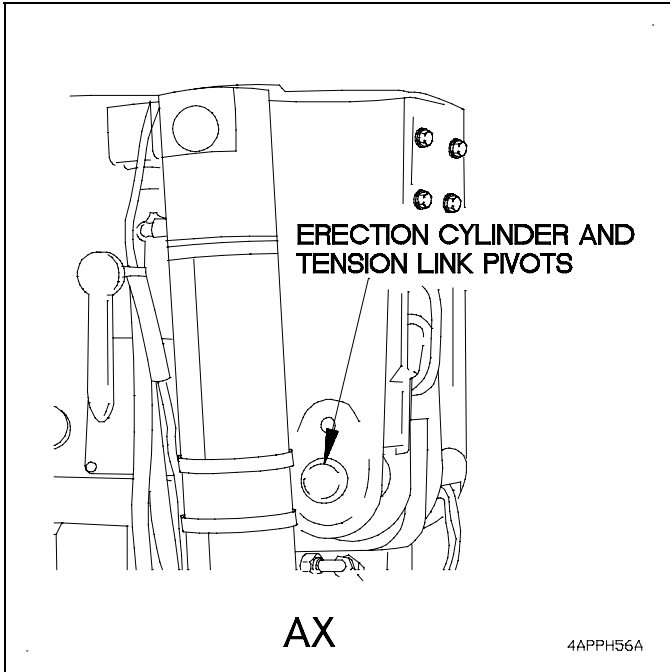

H-8. LUBRICATION LOCAL VIEWS (CONT)

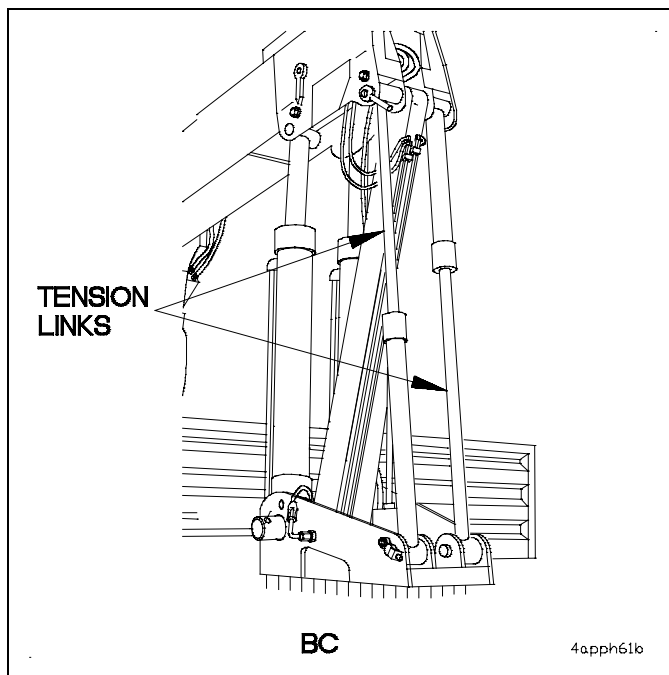
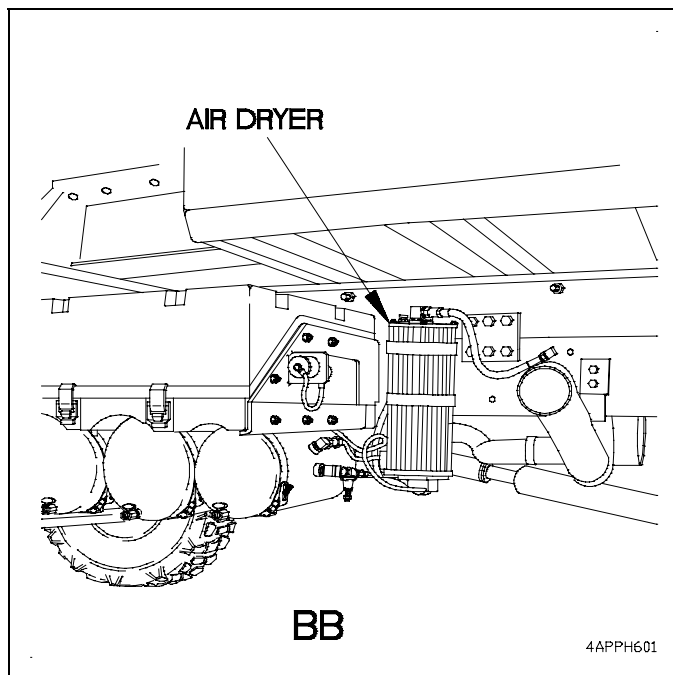

H-9. LUBRICATION NOTES

1. **ENGINE CRANKCASE.** Check engine oil level daily. Change engine oil at initial 5,000 miles (8,045 km). During the remainder of the 12,000 mile (19,308 km)/18 month warranty period, Units participating in AOAP will change engine oil every 6,000 miles (9,654 km). Units not participating in AOAP, will change engine oil every 6,000 miles (9,654 km) or every six months, whichever occurs first. After expiration of engine warranty period, Units participating in AOAP will perform engine oil change as directed by AOAP. Units not participating in AOAP will change engine oil every 6,000 miles (9,654 km) or every six months, whichever occurs first, or when operating in dusty areas or under severe operating conditions, change the oil every 3,000 miles (4,827 km) or every three months, whichever occurs first. Drain engine oil when engine is warm. Refill engine crankcase with OE/HDO specified for the ambient temperature. Engine oil is full when level is within crosshatch marks on the dipstick. Do not overfill.
2. **ENGINE OIL FILTER.** Filter is replaced each time the crankcase is drained. If water or metal particles are detected during oil filter replacement, notify Direct Support Maintenance personnel before refilling crankcase.
3. **TRANSMISSION.** Check transmission oil level daily. Change transmission oil at initial 5,000 miles (8,045 km). During the remainder of the 24 month/unlimited mileage warranty, Units participating in AOAP will perform transmission oil change as directed by AOAP. Units not participating in AOAP will perform transmission oil change every 24,000 miles (38,616 km) or once every two years, whichever occurs first. Drain transmission oil when engine is warm. Refill with OE/HDO specified for ambient temperature. Add oil until the proper level is reached (TM 9-2320-366-10-1). Do not overfill. Replace oil filters each time transmission oil is changed.
4. **POWER STEERING.** Check power steering oil level weekly. Change the oil every 24,000 miles (38,616 km). Disconnect upper and lower hoses from steering gear and drain oil. Refill power steering pump reservoir with OE/HDO specified for the ambient temperature. Reservoir is full when oil is between the two marks on the dipstick. Do not overfill. Remove dipstick, wipe clean and install dipstick fully into reservoir. Remove dipstick and read oil level. Replace oil filter each time power steering oil is changed.

5. FUEL/WATER SEPARATOR. Replace filter element every 6,000 miles (9,654 km) or once every six months, whichever occurs first.

6. FUEL FILTER. The fuel particle filter is replaced when a new fuel/water separator filter element is installed. The normal replacement interval is every 6,000 miles (9,654 km) or once every six months, whichever occurs first.

7. ENGINE COOLANT. Check engine coolant level daily. Change the coolant and flush the cooling system every 24,000 miles (38,616 km) or once every two years, whichever occurs first. Fill radiator overflow tank with an Ethylene Glycol/water mixture as specified in 0-A-548D. Service the cooling system before the specified interval if:

- Coolant is heavily contaminated.
- Engine overheats.
- Oil cooler has failed allowing oil and coolant to mix.

8. HYDRAULIC RESERVOIR AND FILTER (All Models Except M1089). Check oil level weekly and make sure oil level gage reads **F (full)**. Units participating in AOAP will sample oil annually and change oil and filter as directed by AOAP. Units not participating in AOAP will change oil and filter every two years. Drain oil and refill hydraulic reservoir with OE/HDO specified for ambient operating temperature. Fill hydraulic reservoir until oil level gage reads **F (full)**. Do not overfill. Replace oil filter each time oil is changed.

9. DRIVE SHAFT UNIVERSAL and SLIP YOKE.

Lubricate drive shafts with GAA every 3,000 miles (4,827 km) or once every three months, whichever occurs first, using a low pressure lubrication gun. If operating conditions are severe or abnormal, service at 1,000 miles (1,609 km) or once every month, whichever occurs first. Perform drive shaft hinging inspection every time drive shafts are serviced (para 9-3).

- UNIVERSAL JOINT:
 - A. Apply grease to both grease fittings until new grease purges from all four bearing caps.
 - B. If grease does not purge from all four bearing caps, perform the following steps:
 - (1) Loosen two screws on bearing cap that does not purge, approximately 1/4 in.
 - (2) Apply grease to grease fitting for bearing cap that does not purge until bearing cap purges.
 - (3) Remove and discard the two screws loosened in step (1).
 - (4) Position two replacement screws in bearing cap and tighten down evenly.
 - (5) Tighten two screws to 26-35 lb-ft (35-47 N·m).
- SLIP JOINT:
 - A. Apply grease until grease appears at the vent in the welch plug.
 - B. Place your finger over the welch plug vent and add grease until grease purges from the dust seal.
 - C. If grease does not purge from the dust seal, inspect drive shaft slip yoke (para 9-2).

10. AIR/HYDRAULIC POWER UNIT and BACKUP HYDRAULIC PUMP. Change OHA oil every 24,000 miles (38,616 km) or once every two years, whichever occurs first. To service air/hydraulic power unit and backup hydraulic pump refer to vehicle paragraph number 19-8. Air Transportability Hydraulic System Service.

11. ALL AXLE DIFFERENTIALS. Check oil level in differentials every 3,000 miles (4,827 km). Check oil level with vehicle parked on level surface and axle differential at ambient temperature, allowing at least one hour to cool down after vehicle operation. If oil is checked when axle differential is hot, it is normal for oil to spill out of the port due to expansion from the heat. Oil level is considered full if it is within one inch of the bottom of the fill port. If oil spills from the fill port when the axle differential is cool, it is overfull. Allow oil to drain until no more drains out. If the oil level is more than one inch below the bottom of the fill port, refill axle differential with GO specified for the ambient temperature until level with bottom of fill port. Change the oil every 24,000 miles (38,616 km) or once every two years, whichever occurs first. Drain oil when hot after operation.

H-9. LUBRICATION NOTES (CONT)

12. FRONT AXLE WHEEL END PLANETARY HUBS. There are two lube intervals for the front axle wheel end planetary hubs.

- a. Check and fill front axle wheel end planetary hubs every 3,000 miles (4,827 km) or once every three months, whichever occurs first, as follows:
 - (1) Position vehicle on a level surface. Allow 15 minutes for vehicle to cool before checking oil levels.
 - (2) Position fill port at 4 o'clock position. If oil flows from fill port when plug is loosened, let oil drain to correct level. If oil level is below fill port, fill hub with GO specified for the ambient temperature until oil is level with fill port.
- b. Drain and fill front axle wheel end planetary hubs every 24,000 miles (38,616 km) or once every two years, whichever occurs first, following the repacking of the inner wheel bearings, or whenever wheel end assemblies are taken apart for other maintenance as follows:
 - (1) Position vehicle on a level surface.
 - (2) Position fill port at the 6 o'clock (down) position.
 - (3) Drain hub oil (allow a minimum of 15 minutes for oil to drain down from vent tubes).
 - (4) Refill hubs with 11-13 ounces of GO specified for the ambient temperature.

13. TIE ROD ENDS. Lubricate tie rod ends with GAA every 6,000 miles (9,654 km) or once every six months, whichever occurs first, using a low pressure lubrication gun, until new grease is seen purging from the boot area. If operating conditions are severe or abnormal, service at 1,000 miles (1,609 km) or once every month, whichever occurs first.

14. WINCH CABLES:

CAUTION

Do not use dry cleaning solvent to clean winch cables. Use of dry cleaning solvent will remove lubricant from inner strands of winch cables. Failure to comply may result in damage to equipment.

- a. After winch operation:

Refer to FM 5-125.
- b. Care of wire rope:

Refer to FM 5-125.
- c. Inspection of wire rope:

Refer to FM 5-125.
- d. Every six months:
 - (1) Unwind entire length of winch cable (TM 9-2320-366-10-1).
 - (2) Soak and clean winch cable with new OE/HDO 30.
 - (3) Wipe off excess OE/HDO 30.
 - (4) Coat winch cable with GW.
 - (5) Rewind winch cable (TM 9-2320-366-10-1).

15. 15K SRW. Check 15K SRW gear oil level every 6,000 miles (9,654 km) or once every six months, whichever occurs first. Refill 15K SRW with GO specified for ambient temperature. Change oil every 12,000 miles (19,308 km) or once every year, whichever occurs first. Use procedure (a) to check and fill oil level; use procedure (b) to change oil.

a. Check and fill oil level as follows:

- (1) Shift the freespool mechanism to the disengage position so the drum can be freely rotated.
- (2) Rotate the drum to where either plug is near the top of the 15K SRW. Remove the plug.
- (3) Rotate the drum 90 degrees in the direction that allows the other plug to be near the top of the 15K SRW. Remove the plug.

NOTE

Oil level is full if a small amount of oil runs out of lower plug.

- (4) Add oil until a small amount of oil runs out of lower plug hole.
- (5) Apply adhesive (Item 3, Appendix D) to plug and position plug in top hole.
- (6) Rotate drum until open hole is at top.
- (7) Apply adhesive (Item 3, Appendix D) to plug and position plug in top hole.
- (8) Tighten plugs to 13-15 lb-ft (18-20 N·m).

b. Change oil as follows:

- (1) Shift the freespool mechanism to the disengage position so the drum can be freely rotated.
- (2) Rotate the drum to where either plug is near the top of the 15K SRW. Remove the plug.
- (3) Rotate the drum 90 degrees in the direction that allows the other plug to be near the top of the 15K SRW. Remove the plug.
- (4) Position drain pan (Item 39, Appendix C) under 15K SRW.
- (5) Rotate the drum until either hole is straight down to the bottom of the 15K SRW. Allow the oil to drain completely.
- (6) Rotate the drum until either hole is at top.

NOTE

Oil level is full if a small amount of oil runs out of lower plug.

- (7) Add oil until a small amount of oil runs out of lower plug hole.
- (8) Apply adhesive (Item 3, Appendix D) to plug and position plug in top hole.
- (9) Rotate drum until open hole is at top.
- (10) Apply adhesive (Item 3, Appendix D) to plug and position plug in top hole.
- (11) Tighten plugs to 13-15 lb-ft (18-20 N·m).

16. TOWING PINTLE. Lubricate towing pintle with GAA every 6,000 miles (9,654 km) or once every six months, whichever occurs first, using a low pressure lubrication gun until new grease is seen purging.

H-9. LUBRICATION NOTES (CONT)

WARNING

- **Dry Cleaning Solvent (P-D-680) is TOXIC and flammable. Wear protective goggles and gloves; use only in well-ventilated area; avoid contact with skin, eyes, and clothes, and do not breath vapors. Keep away from heat or flame. Never smoke when using solvent; the flashpoint for Type I Dry Cleaning Solvent is 100°F (38°C) and for Type II is 138°F (50°C). Failure to comply may result in serious injury or death to personnel.**
- **If personnel become dizzy while using cleaning solvent, immediately get fresh air and medical help. If solvent contacts skin or clothes, flush with cold water. If solvent contacts eyes, immediately flush eyes with water and get medical attention. Failure to comply may result in injury to personnel.**

17. ENGINE CRANKCASE BREATHER. Remove crankcase breather and clean with Dry Cleaning Solvent (SD P-D-680) (Item 65, Appendix D) or equivalent, and replace o-ring seal every 6,000 miles (9,654 km) or once every six months, whichever occurs first.

18. FRONT AXLE SPRING BOLT and SPRING SHACKLE. Lubricate front axle spring bolt and spring shackle with GAA every 3,000 miles (4,827 km) or once every three months, whichever occurs first, using a low pressure lubrication gun until grease appears between pins and bushings at both ends of spring bolt and spring shackle. If pins do not accept grease, remove pins. Clean and inspect pins and bushings, replace if necessary. If operating conditions are severe or abnormal, service at 1,000 miles (1,609 km) or once every month, whichever occurs first.

19. BATTERY POSTS. Service batteries in accordance with TM 9-6140-200-14, every 6,000 miles (9,654 km) or once every six months, whichever occurs first.

20. FRONT AXLE SHAFT UNIVERSAL JOINTS and STEERING KNUCKLES. Lubricate universal joints every 3,000 miles (4,827 km) or once every three months, whichever occurs first. Lubricate steering knuckles with GAA every 6,000 miles (9,654 km) or once every six months, whichever occurs first, using a low pressure lubrication gun. If operating conditions are severe or abnormal, service at 1,000 miles (1,609 km) or once every month, whichever occurs first.

21. BRAKE WEDGE and AIR CHAMBER: BRAKE SPIDER, SELF-ADJUSTER MECHANISM, AND WEDGE ASSEMBLY. Clean and lubricate (with GAA) areas of spider and hardware that contact the brake shoes. Disassemble, clean and lubricate the self-adjuster mechanism. Clean and lubricate the wedge head, rollers and ramps in the plungers. Clean and lubricate every 6,000 miles (9,654 km). If operating conditions are severe or abnormal, service at 3,000 miles (4,827 km) or once every three months, whichever occurs first, or when any of the following occur:

- Seals are replaced
- Plungers are removed
- Brakes are relined
- Grease becomes contaminated or hardened

22. HYDRAULIC TANK (M1089). Check oil level weekly and make sure oil level indicates FULL. Units participating in AOAP will sample oil annually and change oil and filter as directed by AOAP. Units not participating in AOAP will change oil and filter every two years. Drain oil and refill hydraulic tank with OE/HDO specified for ambient operating temperature. Fill hydraulic tank until oil level is at the FULL mark on the sight glass. Do not overfill. Clean air breather filter and replace hydraulic oil filter when oil is changed. Check oil level with Material Handling Crane (MHC) in the stowed position.

- 23. BOOM WEAR PADS (M1084/M1086/M1089).** Lubricate every 6,000 miles (9,654 km) or once every six months, whichever occurs first. Coat boom wear pads with GAA while boom is extended, for the lower wear pads, boom must be retracted and access cover removed at rear of base boom to grease the upper wear pads. Extend boom in and out while applying grease. This method assures full lubrication for entire length of boom. If operating conditions are severe or abnormal, service at 1,000 miles (1,609 km) or once every month, whichever occurs first.
- 24. HOIST ASSEMBLY DRUM (M1084/M1086/M1089).** Check hoist assembly drum oil level every 6,000 miles (9,654 km) or every six months, whichever occurs first. Check oil level in hoist assembly drum using two pipe plugs (90 degrees apart) on the drum housing. Operate hoist assembly drum so that one pipe plug is positioned at top of drum (fill point) and the other is accessible and level with ground (check level point). Oil level is full if a small quantity of oil runs from check level opening. If oil level is low, add oil at fill opening. To drain, operate drum so that one pipe plug is bottom of drum. Remove plug to drain. Drain and refill with GO specified for the ambient temperature, if oil becomes contaminated.
- 25. SWING DRIVE GEARBOX (M1084/M1086/M1089).** Check swing drive gearbox oil level every 6,000 miles (9,654 km) or once every six months, whichever occurs first. Oil level is checked by removing pipe plug located on side of gear reducer. Oil level is full if a small quantity of oil runs out of opening. Add oil at fill point if necessary. Drain and refill with GO specified for the ambient temperature, if oil becomes contaminated.
- 26. RING GEAR TEETH and PINION GEAR TEETH (M1084/M1086/M1089).** Lubricate every 6,000 miles (9,654 km), after washing, or once every six months, whichever occurs first. Apply a light coat of GAA to ring gear teeth and pinion gear teeth. Operate MHC (TM 9-2320-366-10) to rotate turntable. This will allow grease to be applied to all gear teeth. If operating conditions are severe or abnormal, service at 1,000 miles (1,609 km) or once every month, whichever occurs first.
- 27. FRONT, INTERMEDIATE, and REAR AXLE INNER WHEEL BEARINGS.** Repack inner wheel bearings with GAA every 12,000 miles (19,308 km), when semiannual PMCS inspection of service brakes reveals oil leak from inner hub, or whenever wheel end assemblies are taken apart for other maintenance (para 10-2).
- 28. REAR AXLE BOGIE.** Change oil every 6,000 miles (9,654 km) or once every six months, whichever occurs first. Remove six screws and rear axle bogie cover from one side at a time. Raise axle on opposite side of vehicle to allow oil to drain out. Lower axle and repeat on other side of vehicle. Apply thin bead of silicone adhesive sealant 593 to seating surface of housing. Position cover (with fill plug at the 1 o'clock position) and six screws on housing. Tighten six screws to 24 lb-ft (32 N·m). Remove plug from cover and plug from top of rear axle bogie housing. Refill rear axle bogie with GO specified for the ambient temperature, until level with port on housing cover. Install plugs in cover and housing.
- 29. 15K SELF-RECOVERY WINCH (SRW) CABLE ROLLER FAIRLEADS.** Lubricate with GAA every 6,000 miles (9,654 km) or once every six months, whichever occurs first, using a low pressure lubrication gun. If operating conditions are severe or abnormal, service at 1,000 miles (1,609 km) or once every month, whichever occurs first.
- 30. 30K WINCH CABLE GUIDE ROLLERS and PAY-OUT LOWER TENSION SHEAVE.** Lubricate with GAA every 6,000 miles (9,654 km) or once every six months, whichever occurs first, using a low pressure lubrication gun. If operating conditions are severe or abnormal, service at 1,000 miles (1,609 km) or once every month, whichever occurs first.

H-9. LUBRICATION NOTES (CONT)

WARNING

- **Dry Cleaning Solvent (P-D-680) is TOXIC and flammable. Wear protective goggles and gloves; use only in well-ventilated area; avoid contact with skin, eyes, and clothes, and do not breath vapors. Keep away from heat or flame. Never smoke when using solvent; the flashpoint for Type I Dry Cleaning Solvent is 100°F (38°C) and for Type II is 138°F (50°C). Failure to comply may result in serious injury or death to personnel.**
- **If personnel become dizzy while using cleaning solvent, immediately get fresh air and medical help. If solvent contacts skin or clothes, flush with cold water. If solvent contacts eyes, immediately flush eyes with water and get medical attention. Failure to comply may result in injury to personnel.**

31. SCREEN and PLUG OIL FILTER ASSEMBLY (intermediate axle only). Clean the area around the screen and plug oil filter assembly. Remove the screen and plug oil filter assembly. Clean with Dry Cleaning Solvent (Item 65, Appendix D) or equivalent, every 12,000 miles (19,308 km) or once every year, whichever occurs first. Clean filter each time the differential is drained. If screen is crushed or bent, replace with a new one. Clean the screen cavity in the carrier of all debris and particles. If excessive amount of metal particles are detected during oil filter servicing, notify Direct Support Maintenance personnel before refilling differential.

32. TURNTABLE BEARING (M1084/M1086/M1089). Lubricate with GAA every 6,000 miles (9,654 km), after washing, or once every six months, whichever occurs first. Use a low pressure lubrication gun. Apply lubrication to grease fitting inside turntable bearing. Operate MHC (TM 9-2320-366-10) to rotate turntable bearing through full range of travel between applications of grease. This method assures full lubrication of the turntable bearing. If operating conditions are severe or abnormal, service at 1,000 miles (1,609 km) or once every month, whichever occurs first.

33. TOP and BOTTOM PLATES (M1089). Lubricate every 6,000 miles (9,654 km) or once every six months, whichever occurs first. Coat top and bottom plates with GAA. Extending outriggers in and out while applying grease assures full lubrication for the entire length of top and bottom plates. If operating conditions are severe or abnormal, service at 1,000 miles (1,609 km) or once every month, whichever occurs first.

34. CRANE GREASE FITTINGS (M1084/M1086/M1089). Lubricate with GAA every 6,000 miles (9,654), after washing, or once every six months, whichever occurs first. Use a low pressure lubrication gun. If operating conditions are severe or abnormal, service at 1,000 miles (1,609 km) or once every month, whichever occurs first.

35. UNDERLIFT ASSEMBLY GREASE FITTINGS. Lubricate with GAA every 6,000 miles (9,654), after washing, or once every six months, whichever occurs first. Use a low pressure lubrication gun. If operating conditions are severe or abnormal, service at 1,000 miles (1,609 km) or once every month, whichever occurs first.

36. FRONT LIFTING BEAM. Remove left and right lifting beams and clean with Dry Cleaning Solvent (Item 65, Appendix D) or equivalent, every 6,000 miles (9,654 km) or once every six months, whichever occurs first. Apply a light coat of GAA to lifting beams. If operating conditions are severe or abnormal, service at 1,000 miles (1,609 km) or once every month, whichever occurs first.

37. AIR DRYER. Service air dryer (para 23-11) every 12,000 miles (19,308 km) or annually, whichever occurs first.

38. TENSION LINKS. Lubricate tension link(s) every three months with GAA.

APPENDIX J ADDITIONAL AUTHORIZATION LIST (AAL)

Section I. INTRODUCTION

J-1. SCOPE

This appendix lists additional items you are authorized for the support of the MTV.

J-2. GENERAL

This list identifies items that do not have to accompany the MTV and that do not have to be turned in with it. These items are all authorized to you by Common Tables of Allowance (CTA), Modification Table of Organization and Equipment (MTOE), Tables of Distribution and Allowances (TDA), or Joint Table of Allowance (JTA).

J-3. EXPLANATION OF LISTING

National Stock Numbers, description, and quantities are provided to help you identify and request the additional items you require to support this equipment.

Section II. ADDITIONAL AUTHORIZATION LIST

(1) National Stock Number	(2) Description (CAGE) Part Number	(3) U/M	(4) Qty Auth
6685-01-193-1733	10,000 PSI Transducer: (19207) 12258956	EA	1

APPENDIX K TRANSMISSION/TRANSMISSION CONTROLS ADAPTABILITY CHART

Section I. INTRODUCTION

K-1. INTRODUCTION

This appendix lists the various transmission controls and configuration modifications that may be required to permit the transmission to function correctly. This appendix will guide the mechanic through the hardware selection process by identifying compatibility issues between the transmission controls (WTEC II/WTEC III) and the numerous revisions of the Allison MD3070PT transmission (PRE-ID w/ 24-pin connector, PRE-ID w/ 31-pin connector, TID 1, TID 2, and TID 3). Refer to Figure 1. After replacing any component of the transmission controls or the transmission assembly, perform calibration procedures in TM 9-2320-366-20-4 paragraph 8-2 or 8-3.

K-2. EXPLANATION OF COLUMNS

- a. **Column (1) - Installed Controls or Controls Being Installed.** This column lists all of the variables concerning which version of transmission controls are installed in the vehicle, or may need to be installed, to communicate correctly with the transmission.
- b. **Column (2) - Installed Transmission or Transmission Being Installed.** This column lists all of the various revisions of the Allison MD3070PT transmissions that may be installed in the vehicle.
- c. **Column (3) - Required Modification.** This column lists the various electrical interface (hardware) modifications that may be required to allow the transmission controls to communicate with the transmission.

K-3. HOW TO USE THIS CHART

- a. Determine which controls and transmission are installed in the vehicle.
- b. Determine which component requires replacement.
- c. Read across the row to column (3) to determine the required modification.

Section II.

TRANSMISSION/TRANSMISSION CONTROLS ADAPTABILITY CHART

(1) Installed Controls or Controls Being Installed	(2) Installed Transmission or Transmission Being Installed	(3) Required Modification (Refer to Section III)
WTEC II (with 24-pin connector)	PRE-ID w/ 24-pin connector (transmission serial number prior to 6510032369)	No modification required.
WTEC II (with 24-pin connector)	PRE-ID w/ 31-pin connector (transmission serial number 6510032369 to 6510090785)	Install 31-pin connector.
WTEC II (with 24-pin connector)	TID 1 (transmission serial number 6510090786 to 6510142171)	Install 31-pin connector.
WTEC II (with 24-pin connector)	TID 2 (transmission serial number 6510142172 to 6510262116)	Install 31-pin connector and replace transmission internal wiring harness.

TRANSMISSION/TRANSMISSION CONTROLS ADAPTABILITY CHART (CONT)

(1) Installed Controls or Controls Being Installed	(2) Installed Transmission or Transmission Being Installed	(3) Required Modification (Refer to Section III)
WTEC II (with 24-pin connector)	TID 3 (transmission serial number 6510262117 and subsequent)	Install 31-pin connector, replace transmission internal wiring harness, and reprogram WTEC II TEPSS. ¹
WTEC II (with 31-pin connector)	PRE-ID w/ 24-pin connector (transmission serial number prior to 6510032369)	Install adapter cable assembly.
WTEC II (with 31-pin connector)	PRE-ID w/ 31-pin connector (transmission serial number 6510032369 to 6510090785)	No modification required.
WTEC II (with 31-pin connector)	TID 1 (transmission serial number 6510090786 to 6510142171)	No modification required.
WTEC II (with 31-pin connector)	TID 2 (transmission serial number 6510142172 to 6510262116)	Replace transmission internal wiring harness.
WTEC II (with 31-pin connector)	TID 3 (transmission serial number 6510262117 and subsequent)	Replace transmission internal wiring harness and reprogram WTEC II TEPSS. ¹
WTEC III (with ECU manufactured prior to October 1999) ²	PRE-ID w/ 24-pin connector (transmission serial number prior to 6510032369)	Install adapter cable assembly and ID harness.
WTEC III (with ECU manufactured prior to October 1999) ²	PRE-ID w/ 31-pin connector (transmission serial number 6510032369 to 6510090785)	Install ID harness.
WTEC III (with ECU manufactured prior to October 1999) ²	TID 1 (transmission serial number 6510090786 to 6510142171)	No modification required.
WTEC III (with ECU manufactured prior to October 1999) ²	TID 2 (transmission serial number 6510142172 to 6510262116)	No modification required.
WTEC III (with ECU manufactured prior to October 1999) ²	TID 3 (transmission serial number 6510262117 and subsequent)	Reprogram WTEC III ECU ¹ or install new WTEC III ECU (P/N 12421787- 002).
WTEC III (with ECU manufactured after to October 1999) ³	PRE-ID w/ 24-pin connector (transmission serial number prior to 6510032369)	Install adapter cable assembly and ID harness.
WTEC III (with ECU manufactured after to October 1999) ³	PRE-ID w/ 31-pin connector (transmission serial number 6510032369 to 6510090785)	Install ID harness.
WTEC III (with ECU manufactured after to October 1999) ³	TID 1 (transmission serial number 6510090786 to 6510142171)	No modification required.

¹ Reprogramming can only be accomplished by an authorized Allison Transmission distributor. You must provide the transmission serial number of the transmission being installed to ensure correct reprogramming. If at a later time, an earlier version transmission is installed in a WTEC II equipped vehicle, WTEC II TEPSS will require reprogramming again.

² Vehicle serial number 012477 and lower. Refer to Figure 1.

³ Vehicle serial number 012478 and higher. Refer to Figure 1.

(1) Installed Controls or Controls Being Installed	(2) Installed Transmission or Transmission Being Installed	(3) Required Modification (Refer to Section III)
WTEC III (with ECU manufactured after to October 1999) ³	TID 2 (transmission serial number 6510142172 to 6510262116)	No modification required.
WTEC III (with ECU manufactured after to October 1999) ³	TID 3 (transmission serial number 6510262117 and subsequent)	No modification required.

Section III.

MODIFICATION PARTS IDENTIFICATION

Identification	Part Number	Description
31-pin connector	29519127	Converts a transmission external wiring harness from a 24-pin ("D" type) connector to a 31-pin (round type) connector.
Transmission internal wiring harness	29529474	Converts a TID 2 transmission to a TID 1 configuration to allow WTEC II controls to communicate with the transmission.
ID harness	200100	Allows WTEC III controls to communicate with a PRE-ID transmission.
Adapter cable assembly	29519210	Adapts a PRE-ID transmission with 24-pin ("D" type) connector to a transmission external wiring harness with a 31-pin (round) connector.

MODIFICATION PARTS IDENTIFICATION (CONT)

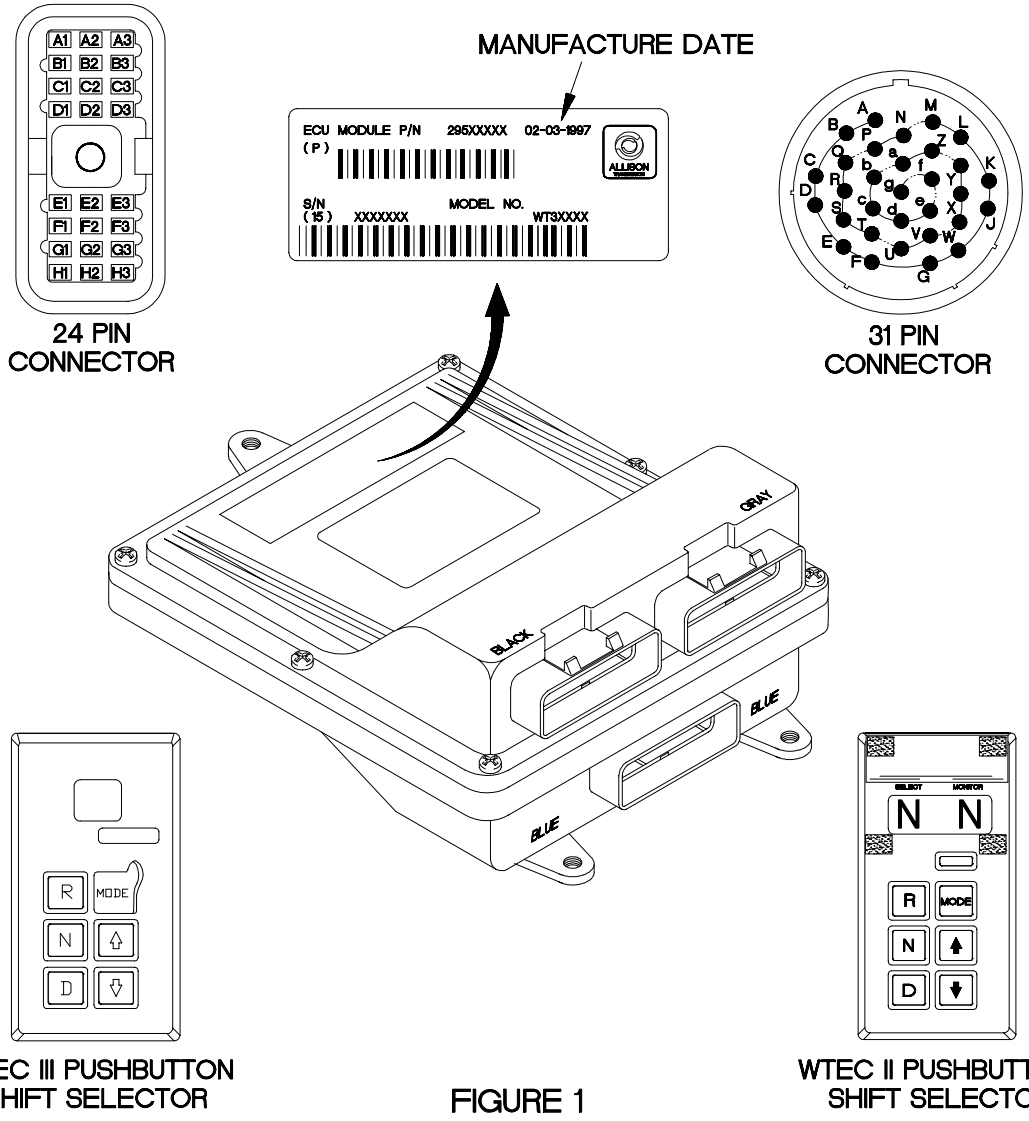

FIGURE 1

4WTEC111

SUBJECT INDEX

Subject	Para	Subject	Para
A		A (Cont)	
Accelerator Pedal Replacement	4-21	Auxiliary	
Air		Panel Cable Assembly Replacement	7-58
Cab Leveling Air Springs Do Not Operate	2-31	Panel Replacement	7-8
Compressor Inlet and Outlet Coolant Tubes Replacement	6-11	Starter Solenoid Replacement	7-6
Charge Air Cooler to Air Inlet Elbow Tubes and Hoses Replacement	4-5	Axle Troubleshooting	2-25
Intake Air Cleaner Filter Element, Air Cleaner Assembly, and Particle Extraction Tube Replacement	4-2		
Pressure Transmitter Replacement	7-44	B	
Radiator/Charge Air Cooler Replacement	6-2	Backup Light Assembly Replacement/Repair	7-36
Transport Troubleshooting	2-31	Batteries	
Air Cleaner		Disconnecting/Connecting Batteries	7-57
Intake Air Cleaner Filter Element, Air Cleaner Assembly, and Particle Extraction Tube Replacement	4-2	Battery	
Alarm		/Battery Cables Replacement	7-55
Audible Alarm Replacement	7-43	Box Replacement	7-56
Chemical Alarm Kit Cable Assembly Replacement	7-59	Tester Replacement	7-54
Troop Transport Alarm Does Not Operate	2-31	to 100 Amp Reverse Polarity Relay 12 VDC Cable Assembly Replacement	7-74
Alternator		to 100 Amp Reverse Polarity Relay 24 VDC Cable Assembly Replacement	7-75
Belts Replacement	7-3	to Shunt Cable Assembly Replacement	7-76
Brackets Replacement	7-4	to Starter Cable Assembly Replacement	7-77
Ground Strap Replacement	7-71	Belt	
100 Amp Alternator Replacement	7-2	Drive Belt and Tension Pulley Replacement	6-13
100 Amp Alternator to Reverse Polarity Relay 12 VDC Cable Replacement	7-72	Belts	
100 Amp Alternator to Reverse Polarity Relay 24 VDC Cable Replacement	7-73	Alternator Belts Replacement	7-3
Amp		Blackout Drive Light Replacement/Repair	7-37
100 Amp Alternator Replacement	7-2	Body	
100 Amp Alternator to Reverse Polarity Relay 12 VDC Cable Replacement	7-72	Dump Body Hydraulic System Troubleshooting	2-32
100 Amp Alternator to Reverse Polarity Relay 24 VDC Cable Replacement	7-73	M1090/M1094 Dump Body Switch Replacement/Adjustment	7-23
100 Amp Reverse Polarity Relay Replacement	7-30	Box	
100 Amp Voltage Regulator Replacement	7-5	Battery Box Replacement	7-56
Assembly		Crane Remote Control Box Repair	7-32
General Assembly Instructions	2-45	M1084/M1086 Junction Box Assembly Replacement/Repair	7-27
Audible Alarm Replacement	7-43	M1089 Junction Box Assembly Replacement/Repair	7-32
		M1089 Wrecker Remote Control Box Repair	7-35
		Brackets	
		Alternator Brackets Replacement	7-4

SUBJECT INDEX (CONT)

Subject	Para	Subject	Para
B (Cont)		C (Cont)	
Breather		Cable (Cont)	
Crankcase Breather Replacement	3-5	M1089 LH or RH 30K Winch Cable Drum Tensioner Does Not Operate	2-37
C		M1093/M1094 Cab Clearance and Marker Lights Lower Cable Replacement	7-62
Cab		M1093/M1094 Cab Clearance and Marker Lights Upper Cable Replacement	7-63
Clearance Marker Lights Cable Assembly Replacement	7-66	NATO Power Cable Replacement	7-70
Does Not Lower	2-36	Right-Hand Door and Cab Marker Lights Cable Assembly Replacement	7-64
Does Not Raise	2-36	STE/ICE-R Cable Assembly Replacement	7-65
Left-Hand Door and Cab Marker Lights Cable Assembly Replacement	7-61	Throttle Control Cable Replacement/Adjustment	4-18
Leveling Air Springs Do Not Operate	2-31	Throttle Position Sensor (TPS) Cable Assembly Replacement	4-16
M1093/M1094 Cab Clearance and Marker Lights Lower Cable Replacement	7-62	Windshield Washer Pump Electromagnetic Interference (EMI) Cable Assembly Replacement	7-67
M1093/M1094 Cab Clearance and Marker Lights Upper Cable Replacement	7-63	Windshield Wiper Electromagnetic Interference (EMI) Cable Replacement	7-68
Right-Hand Door and Cab Marker Lights Cable Assembly Replacement	7-64	WTEC II Dashboard Cable Assembly Replacement/Repair	7-10
Tilt and Spare Tire Retainer Troubleshooting	2-36	WTEC III Dashboard Cable Assembly Replacement/Repair	7-11
Tilt, Spare Tire Retainer, and Suspension Compression Will Not Work	2-31	100 Amp Alternator to Reverse Polarity Relay 12 VDC Cable Replacement	7-72
to Chassis Ground Strap Replacement	7-78	100 Amp Alternator to Reverse Polarity Relay 24 VDC Cable Replacement	7-73
Cable		Central	
Auxiliary Panel Cable Assembly Replacement	7-58	Five Central Tire Inflation System (CTIS) Indicator Lights Flashing	2-24
Battery/Battery Cables Replacement	7-55	Tire Inflation System (CTIS) Cable Assembly Replacement	7-60
Battery to Shunt Cable Assembly Replacement	7-76	Tire Inflation System (CTIS) ECU Indicates No Fault Code But System Fails to Inflate or Deflate	2-24
Battery to Starter Cable Assembly Replacement	7-77	Tire Inflation System (CTIS) Troubleshooting	2-24
Battery to 100 Amp Reverse Polarity Relay 12 VDC Cable Assembly Replacement	7-74	Two Steady Mode Lights Illuminate on Central Tire Inflation System (CTIS) ECU	2-24
Battery to 100 Amp Reverse Polarity Relay 24 VDC Cable Assembly Replacement	7-75		
Central Tire Inflation System (CTIS) Cable Assembly Replacement	7-60		
Chemical Alarm Kit Cable Assembly Replacement	7-59		
Left-Hand Door and Cab Marker Lights Cable Assembly Replacement	7-61		

Subject	Para
C (Cont)	
Charge	
Air Cooler to Air Inlet Elbow Tubes and Hoses Replacement	4-5
Turbocharger to Charge Air Cooler Tube and Hoses Replacement	4-4
Radiator/Charge Air Cooler Replacement	6-2
Checking and Stenciling High/Low Hand Throttle Positions	4-22
Chemical	
Alarm Kit Cable Assembly Replacement	7-59
Circuit Breaker, Diode, and Relay Replacement	7-9
Cleaning	
General Cleaning Instructions	2-42
Clearance	
And Marker Light Assemblies Replacement	7-38
Cab Clearance and Marker Lights Cable Assembly Replacement	7-66
M1093/M1094 Cab Clearance and Marker Lights Lower Cable Assembly Replacement	7-62
M1093/M1094 Cab Clearance and Marker Lights Upper Cable Assembly Replacement	7-63
Composite	
Front Light Assembly Replacement/Repair	7-40
Taillight Assembly Replacement/Repair	7-39
Compressor	
Air Compressor Inlet and Outlet Coolant Tubes Replacement	6-11
Control	
M1089 Wrecker Remote Control Box Repair	7-35
One Wrecker Function Does Not Operate From Wrecker Remote Control	2-37
Coolant	
Bypass Tube Replacement	6-7
Lower Coolant Hose Replacement	6-10
Temperature Gage Sensor Replacement	7-45
Temperature Light Switch Replacement	7-22
Upper Coolant Tube and Hoses Replacement	6-9
Cooler	
Charge Air Cooler to Air Inlet Elbow Tubes and Hoses Replacement	4-5

Subject	Para
C (Cont)	
Cooling System Maintenance	
Introduction	6-1
Cover	
Valve Cover Replacement	3-3
Crane	
Light Material Handling Crane (LMHC) Does Not Operate	2-31
Light Material Handling Crane (LMHC) Hoist IN Does Not Operate	2-31
Light Material Handling Crane (LMHC) Hoist OUT Does Not Operate	2-31
M1084/M1086 Crane Power Cable Assembly Replacement	7-79
Crane Remote Control Box Repair	7-32
Crankcase Breather Replacement	3-5
CTIS	
Central Tire Inflation System (CTIS) Cable Assembly Replacement	7-60
Central Tire Inflation System (CTIS) Troubleshooting	2-24
Central Tire Inflation System (CTIS) ECU Indicates No Fault Code But System Fails to Inflate or Deflate	2-24
CTIS Repeatedly Resumes Cycling 30 Seconds After Indicator Lights Stop Flashing	2-24
Five Central Tire Inflation System (CTIS) ECU Indicator Lights Flashing	2-24
Four CTIS ECU Indicator Lights Flashing	2-24
Two Steady Mode Lights Illuminate on Central Tire Inflation System (CTIS) ECU	2-24
Cylinder	
M1084/M1086 Jack Cylinder Proximity Sensor Replacement	7-51
M1089 Fold Cylinder Does Not Operate	2-33
M1089 Stinger/Telescopic Lift Cylinders/Fold Cylinder/Right 30K Winch Do Not Operate	2-33
M1089 Underlift Telescopic Lift Cylinder(s) Does Not Operate	2-33
Cylinders	
M1089 Stinger/Telescopic Lift Cylinders/Fold Cylinder/Right 30K Winch Do Not Operate	2-33

SUBJECT INDEX (CONT)

Subject	Para	Subject	Para
D		E (Cont)	
Dashboard		ECU (Cont)	
WTEC II Cable Assembly Replacement/ Repair	7-10	Four CTIS ECU Indicator Lights Flashing	2-24
WTEC III Cable Assembly Replacement/ Repair	7-11	Frequency ECU Replacement	7-31
Differential		Two Steady Modes Lights Illuminate on Central Tire Inflation System (CTIS) ECU	2-24
Axle Differential(s) Noisy	2-25	Windshield Wiper ECU Replacement	7-69
Fan and Differential Lock Solenoids Replacement	7-24	WTEC II Transmission ECU Pushbutton Shift Selector (TEPSS) Dimmer Module Replacement	7-13
Dimmer		Electrical Gages Replacement	7-14
Switch Replacement	7-12	EMI	
WTEC II Transmission ECU Pushbutton Shift Selector (TEPSS) Dimmer Module Replacement	7-13	Windshield Washer Pump Electromagnetic Interference (EMI) Cable Assembly Replacement	7-67
Diode		Windshield Wiper Electromagnetic Interference (EMI) Cable Replacement	7-68
Circuit Breaker, Diode, and Relay Replacement	7-9	Engine	
Disassembly		and Transmission Oil Sampling Valves Replacement	3-6
General Disassembly Instructions	2-41	Fan and Fan Clutch Assembly Replacement	6-14
Disconnecting/Connecting Batteries	7-57	Maintenance Introduction	3-1
Display		Speed Sensor Replacement/ Adjustment	7-46
Lighted Indicator Display Replacement/ Repair	7-16	Ether	
Door		Sensor Replacement	7-47
Left-Hand Door and Cab Marker lights Cable Assembly Replacement	7-61	Starting Aid Replacement	4-15
Right-Hand Door and Cab Marker lights Cable Assembly Replacement	7-64	Exhaust	
Drive Belt and Tension Pulley Replacement	6-13	Muffler and Exhaust Heat Shields Replacement	5-2
Drum		Pipe Replacement	5-3
M1089 LH or RH 30K Winch Cable Drum Tensioner Does Not Operate	2-37	System Maintenance Introduction	5-1
Dump		External	
Body Hydraulic System Troubleshooting	2-32	No Service or External Hydraulic Power From M1089	2-33
M1090/M1094 Dump Body Switch Replacement/Adjustment	7-23		
E		F	
ECU		Fan	
Central Tire Inflation System (CTIS) ECU Indicates No Fault Code But System Fails to Inflate or Deflate	2-24	and Differential Lock Solenoids Replacement	7-24
Five Central Tire Inflation System (CTIS) ECU Indicator Lights Flashing	2-24	Engine Fan and Fan Clutch Assembly Replacement	6-14
		Radiator Fan Shrouds Replacement	6-4

Subject Para

F (Cont)

Filter
 Fuel Filter and Filter Base Replacement 4-12
 Fuel Filter Tubes Replacement 4-10
 Fuel/Water Separator and Filter
 Replacement 4-13
 Oil Filter Replacement 3-4
 Five Central Tire Inflation System (CTIS)
 ECU Indicator Lights Flashing 2-24
 Flasher Unit Replacement 7-25
 Fold
 M1089 Fold Cylinder Does Not
 Operate 2-33
 M1089 Stinger/Telescopic Lift
 Cylinders/Fold Cylinder/Right
 30K Winch Do Not Operate 2-33
 Four CTIS ECU Indicator Lights
 Flashing 2-24
 Freespool
 Main Winch LH Freespool Does Not
 Operate 2-37
 Main Winch RH Freespool Does Not
 Operate 2-37
 Main Winch LH or RH Freespool(s)
 Does Not Operate 2-37
 Frequency ECU Replacement 7-31
 Front
 Composite Front Light Assembly
 Replacement/Repair 7-40
 Intervehicular 12 VDC (7 Pin) Cable
 Replacement 7-81
 Lights Cable Assembly Replacement 7-82
 Fuel
 Filter and Filter Base Replacement 4-12
 Filter Tubes Replacement 4-10
 Hoses Replacement 4-9
 Pressure Regulating Valve Replacement 4-3
 Ratio Control Tube Replacement 4-6
 System Bleeding 4-11
 System Maintenance Introduction 4-1
 Tank Replacement 4-8
 /Water Separator and Filter Replacement . . . 4-13

G

Gages
 Electrical Gages Replacement 7-14
 (Non-Electrical) Maintenance

Subject Para

G (Cont)

General
 Assembly Instructions 2-45
 Cleaning Instructions 2-42
 Disassembly Instructions 2-41
 Inspection Instructions 2-43
 Installation Instructions 2-46
 Removal Instructions 2-40
 Repair Instructions 2-44
 Governor
 Linkage Replacement 4-12
 Ground Handling 2-39
 Ground Strap
 Alternator Ground Strap Replacement 7-71
 Cab to Chassis Ground Strap
 Replacement 7-78

H

Hand
 Throttle Lever Replacement/
 Adjustment 4-17
 Throttle Checking and Stenciling
 High/Low Hand Throttle Positions 4-22
 Headlight and Housing Replacement/
 Repair/ Adjustment 7-41
 Heater
 Personnel Heater Hoses Replacement 6-8
 Hoist
 Light Material Handling Crane (LMHC)
 Hoist IN Does Not Operate 2-31
 Light Material Handling Crane (LMHC)
 Hoist OUT Does Not Operate 2-31
 Horn and Bracket Replacement 7-53
 Hose
 Lower Coolant Hose Replacement 6-10
 Hoses
 Charge Air Cooler to Air Inlet Elbow
 Tubes and Hoses Replacement 4-5
 Fuel Hoses Replacement 4-9
 Personnel Heater Hoses Replacement 6-8
 Turbocharger to Charge Air Cooler
 Tube and Hoses Replacement 4-4
 Upper Coolant Tube and Hoses
 Replacement 6-9
 Housing
 Headlight and Housing Replacement/
 Repair/Adjustment 7-41
 Hydraulic
 Dump Body Hydraulic System
 Troubleshooting 2-32

SUBJECT INDEX (CONT)

Subject	Para	Subject	Para
H (Cont)		I (Cont)	
Hydraulic (Cont)		Introduction (Cont)	
M1084/M1086 Material Handling Crane (MHC) Hydraulic Troubleshooting	2-35	Electrical System Maintenance Introduction	7-1
No Service or External Hydraulic Power From M1089	2-33	Engine Maintenance Introduction	3-1
Steering Hydraulic System Troubleshooting	2-30	Exhaust System Maintenance Introduction	5-1
Wrecker Hydraulic System Troubleshooting	2-33	Fuel System Maintenance Introduction	4-1
I		J	
Indicator		Jack	
CTIS Repeatedly Resumes Cycling 30 Seconds After Indicator Lights Stop Flashing	2-24	M1084/M1086 Jack Cylinder Proximity Sensor Replacement	7-51
Five Central Tire Inflation System (CTIS) ECU Indicator Lights Flashing	2-24	Junction	
Four CTIS ECU Indicator Lights Flashing	2-24	M1084/M1086 Junction Box Assembly Replacement/Repair	7-27
Lighted Indicator Display Replacement/Repair	7-16	M1089 Junction Box Assembly Replacement/Repair	7-32
Inlet		K	
Charge Air Cooler to Air Inlet Elbow Tubes and Hoses Replacement	4-5	Kit	
Inspection		Chemical Alarm Kit Cable Assembly Replacement	7-59
General Inspection Instructions	2-43	L	
Installation		Leans to One Side or Rear Of Vehicle Sags	2-28
General Installation Instructions	2-46	Left	
Instructions		Hand Door and Cab Marker Lights Cable Assembly Replacement	7-61
General Assembly Instructions	2-45	M1089 Stifflegs/Left 30K Winch/15K Self-Recovery Winch (SRW) Do Not Operate	2-33
General Cleaning Instructions	2-42	Lever	
General Disassembly Instructions	2-41	Hand Throttle Lever Replacement/ Adjustment	4-17
General Inspection Instructions	2-43	Throttle Control Lever Replacement	4-20
General Installation Instructions	2-46	Lifting Plate Replacement	3-2
General Removal Instructions	2-40	Light	
General Repair Instructions	2-44	Backup Light Assembly Replacement/ Repair	7-36
Instrument		Blackout Drive Light Replacement/ Repair	7-37
Panel Assembly Replacement/Repair	7-15		
Intake Air Cleaner Filter Element, Air Cleaner Assembly, and Particle Extraction Tube Replacement	4-2		
Introduction			
Cooling System Maintenance Introduction	6-1		

Subject	Para
L (Cont)	
Light (Cont)	
Clearance and Marker Light Assemblies	
Replacement	7-38
Coolant Temperature Light Switch	
Replacement	7-22
Composite Front Light Assembly	
Replacement/Repair	7-40
No Overspeed Warning Light and/or	
Overspeed Pressure Change	2-24
Lighted Indicator Display Replacement/	
Repair	7-16
Lights	
Cab Clearance Marker Lights Cable	
Assembly Replacement	7-66
Five Central Tire Inflation System (CTIS)	
ECU Indicator Lights Flashing	2-24
Four CTIS ECU Indicator Lights	
Flashing	2-24
Left Hand Door and Cab Marker Lights	
Cable Assembly Replacement	7-61
M1093/M1094 Cab Clearance and	
Marker Lights Lower Cable	
Replacement	7-62
M1093/M1094 Cab Clearance and	
Marker Lights Upper Cable	
Replacement	7-63
Right Hand Door and Cab Marker Lights	
Cable Assembly Replacement	7-64
Two Steady Mode Lights Illuminate on	
Central Tire Inflation System (CTIS)	
ECU	2-24
Linkage	
Governor Linkage Replacement	4-12
LMHC	
Light Material Handling Crane (LMHC)	
Does Not Operate	2-31
Light Material Handling Crane (LMHC)	
Hoist IN Does Not Operate	2-31
Light Material Handling Crane (LMHC)	
Hoist OUT Does Not Operate	2-31
Lower Coolant Hose Replacement	6-10
Lubrication	
AOAP Sampling Intervals	H-3
General	H-1
Intervals	H-6
Key	H-5
Local Views	H-8
Locator Views	H-7
Notes	H-9
Oil Filters	H-2
Warranty Hardtime Statement	H-4

Subject	Para
M	
Main	
Light Switch Replacement	7-17
Winch LH Freespool Does Not	
Operate	2-37
Main Winch RH Freespool Does Not	
Operate	2-37
Main Winch LH or RH Freespool(s)	
Does Not Operate	2-37
Maintenance Introduction	2-38
Marker	
Cab Clearance Marker Lights Cable	
Assembly Replacement	7-66
Clearance and Marker Light Assemblies	
Replacement	7-38
Left Hand Door and Cab Marker Lights	
Cable Assembly Replacement	7-61
M1093/M1094 Cab Clearance and	
Marker Lights Lower Cable	
Assembly Replacement	7-62
M1093/M1094 Cab Clearance and	
Marker Lights Upper Cable	
Assembly Replacement	7-63
Right Hand Door and Cab Marker Lights	
Cable Assembly Replacement	7-64
Material Handling Crane	
M1084/M1086 Material Handling Crane	
(MHC) Hand Pump Will Not Work	2-35
M1084/M1086 Material Handling Crane	
(MHC) Hydraulic Troubleshooting	2-35
M1089 Material Handling Crane (MHC)	
Does Not Operate	2-33
M1089 Material Handling Crane (MHC)	
Hand Pump Does Not Work	2-33
MHC	
M1084/M1086 Material Handling Crane	
(MHC) Hand Pump Will Not Work	2-35
M1084/M1086 Material Handling Crane	
(MHC) Hydraulic Troubleshooting	2-35
M1089 Material Handling Crane (MHC)	
Does Not Operate	2-33
M1089 Material Handling Crane (MHC)	
Hand Pump Does Not Work	2-33
Module	
WTEC II Transmission ECU Pushbutton	
Shift Selector (TEPSS) Dimmer Module	
Replacement	7-13
Motor	
Starting Motor Replacement	7-7
Muffler and Exhaust Heat Shields	
Replacement	5-2

SUBJECT INDEX (CONT)

Subject	Para	Subject	Para
M (Cont)		M (Cont)	
M1084/M1086		M1090/M1094	
Jack Cylinder Proximity Sensor		Dump Body Switch Replacement/	
Replacement	7-51	Adjustment	7-23
Junction Box Assembly		M1093/M1094	
Replacement/Repair	7-27	Cab Clearance and Marker Lights Lower	
Material Handling Crane (MHC) Hand		Cable Replacement	7-62
Pump Will Not Work	2-35	Cab Clearance and Marker Lights Upper	
Material Handling Crane (MHC) Hydraulic		Cable Replacement	7-63
Troubleshooting	2-35		
M1088/M1089		N	
Stationary Worklight Assembly		NATO Power Cable Replacement	7-70
Replacement/Repair	7-42	No	
M1089		Overspeed Warning Light and/or	
Fold Cylinder Does Not Operate	2-33	Overspeed Pressure Change	2-24
Junction Box Assembly		Response When Turning Steering Wheel	2-26
Replacement/Repair	7-32	Service or External Hydraulic Power	
LH 30K Winch Does Not Operate	2-33	From M1089	2-33
LH or RH 30K Winch Cable Drum			
Tensioner Does Not Operate	2-37	O	
LH or RH 30K Winch Does Not		Oil	
Pay-In	2-37	Filter Replacement	3-4
Material Handling Crane (MHC) Does		Pressure Switch Replacement	7-48
Not Operate	2-33	Pressure Transducer Replacement	7-49
Material Handling Crane (MHC) Hand		One Wrecker Function Does Not Operate	
Pump Does Not Work	2-33	From Wrecker Remote Control	2-37
No Service or External Hydraulic Power		Orifice Tube Assembly Replacement	4-5
From M1089	2-33	Overflow	
RH 30K Winch Does Not Operate	2-33	Radiator Overflow Tank and Bracket	
Stiffleg(s) Does Not Operate or Operates		Replacement/Repair	6-3
Slowly	2-33	Overspeed	
Stifflegs/Left 30K Winch/15K		No Overspeed Warning Light and/or	
Self-Recovery Winch (SRW) Do Not		Overspeed Pressure Change	2-24
Operate	2-33		
Stinger Does Not Operate	2-33	P	
Stinger/Telescopic Lift Cylinders/Fold		Panel	
Cylinder/Right 30K Winch Do Not		Auxiliary Panel Cable Assembly	
Operate	2-33	Replacement	7-58
Terminal Board Replacement	7-33	Auxiliary Panel Replacement	7-8
Underlift Telescopic Lift Cylinder(s) Does		Instrument Panel Assembly Replacement/	
Not Operate	2-33	Repair	7-15
Wrecker Control Panel Toggle Switch		M1089 Wrecker Control Panel Toggle	
Replacement	7-34	Switch Replacement	7-34
Wrecker Control Panel Wiring Harness		Pay-In	
Replacement	7-83	M1089 LH or RH 30K Winch Does	
Wrecker Remote Control Box Repair	7-35	Not Pay-In	2-37

Subject	Para
P (Cont)	
Pedal	
Accelerator Pedal Replacement	4-21
Personnel	
Heater Hoses Replacement	6-8
Pipe	
Exhaust Pipe Replacement	5-3
Pneumatic	
Wrecker Pneumatic Troubleshooting	2-37
Preparation	
for Storage or Shipment	2-48
for Storage or Shipment Introduction	2-47
Pressure	
Air Pressure Transmitter Replacement	7-44
No Overspeed Warning Light and/or Overspeed Pressure Change	2-24
Oil Pressure Switch Replacement	7-48
Oil Pressure Transducer Replacement	7-49
Pulls	
Wanders, Pulls to One Side, or Shimmies	2-26
Wanders, Pulls to One Side, or Shimmies	2-28
Pump	
M1084/M1086 Material Handling Crane (MHC) Hand Pump Will Not Work	2-35
M1089 Material Handling Crane (MHC) Hand Pump Does Not Work	2-33
Water Pump and Fittings Replacement	6-12
Windshield Washer Pump Electromagnetic Interference (EMI) Cable Assembly Replacement	7-67
Pushbutton	
Start Inhibit Pushbutton Switch Replacement	7-19
Starter Pushbutton Switch Replacement	7-20
WTEC II Transmission ECU Pushbutton Shift Selector (TEPSS) Dimmer Module Replacement	7-13
R	
Radiator	
/Charge Air Cooler Replacement	6-2
Fan Shrouds Replacement	6-4
Overflow Tank and Bracket Replacement/ Repair	6-3
Rear	
Leans to One Side or Rear Of Vehicle Sags	2-28

Subject	Para
R (Cont)	
Regulator	
100 Amp Voltage Regulator Replacement	7-5
Relay	
Battery to 100 Amp Reverse Polarity Relay 12 VDC Cable Replacement	7-74
Battery to 100 Amp Reverse Polarity Relay 24 VDC Cable Replacement	7-75
Circuit Breaker, Diode, and Relay Replacement	7-9
100 Amp Alternator to Reverse Polarity Relay 12 VDC Cable Replacement	7-72
100 Amp Alternator to Reverse Polarity Relay 24 VDC Cable Replacement	7-73
100 Amp Reverse Polarity Relay Replacement	7-30
Remote	
Crane Remote Control Box Repair	7-32
M1089 Wrecker Remote Control Box Repair	7-35
One Wrecker Function Does Not Operate From Wrecker Remote Control	2-37
Removal	
General Removal Instructions	2-40
Repair	
General Repair Instructions	2-44
Reverse Polarity	
Battery to 100 Amp Reverse Polarity Relay 12 VDC Cable Replacement	7-74
Battery to 100 Amp Reverse Polarity Relay 24 VDC Cable Replacement	7-75
100 Amp Reverse Polarity Relay Replacement	7-30
100 Amp Alternator to Reverse Polarity Relay 12 VDC Cable Replacement	7-72
100 Amp Alternator to Reverse Polarity Relay 24 VDC Cable Replacement	7-73
Right	
Hand Door and Cab Marker Lights Cable Assembly Replacement	7-64
M1089 Stinger/Telescopic Lift Cylinders/ Fold Cylinder/Right 30K Winch Do Not Operate	2-33
Rocker Switches Replacement	7-18
Rod	
Throttle Control Threaded Rod Replacement	4-19

SUBJECT INDEX (CONT)

Subject	Para	Subject	Para
S		S (Cont)	
Self-Recovery		Speed	
M1089 Stifflegs/Left 30K Winch/15K		Engine Speed Sensor Replacement/	
Self-Recovery Winch (SRW) Do Not Operate	2-33	Adjustment	7-46
15K Self-Recovery Winch (SRW) System		SRW	
Troubleshooting	2-29	15K Self-Recovery Winch (SRW) System	
15K Self-Recovery Winch (SRW) Will		Troubleshooting	2-29
Not Work	2-29	15K Self-Recovery Winch (SRW) Will	
Not Work	2-29	Not Work	2-29
Sensor		Start	
Coolant Temperature Gage Sensor		Inhibit Pushbutton Switch	
Replacement	7-45	Replacement	7-19
Engine Speed Sensor Replacement/		Starter	
Adjustment	7-46	Auxiliary Starter Solenoid Replacement	7-6
Ether Sensor Replacement	7-47	Battery to Starter Cable Assembly	
M1084/M1086 Jack Cylinder Proximity		Replacement	7-77
Sensor Replacement	7-51	Pushbutton Switch Replacement	7-20
Throttle Position Sensor (TPS) Cable		Starting	
Assembly Replacement	4-16	Ether Starting Aid Replacement	4-15
Transmission Engine Speed Sensor		Motor Replacement	7-7
Replacement	7-52	Stationary	
Shift		M1088/M1089 Stationary Worklight	
WTEC II Transmission ECU Pushbutton		Assembly Replacement/Repair	7-42
Shift Selector (TEPSS) Dimmer Module		STE/ICE-R Cable Assembly Replacement	7-65
Replacement	7-13	Steering	
Shimmies		Excessive Play When Turning Steering	
Wanders, Pulls to One Side, or		Wheel	2-26
Shimmies	2-26	Hard or Will Not Work	2-30
Wanders, Pulls to One Side, or		Hydraulic System Troubleshooting	2-30
Shimmies	2-28	No Response When Turning Steering	
Shipment		Wheel	2-26
Preparation for Storage or Shipment	2-48	System Maintenance Introduction	13-1
Preparation for Storage or Shipment		Troubleshooting	2-26
Introduction	2-47	Stiffleg	
Shrouds		M1089 Stiffleg(s) Does Not Operate or	
Radiator Fan Shrouds Replacement	6-4	Operates Slowly	2-33
Shunt		Stifflegs	
Battery to Shunt Cable Assembly		M1089 Stifflegs/Left 30K Winch/15K	
Replacement	7-76	Self-Recovery Winch (SRW) Do Not	
Replacement	7-28	Operate	2-33
Solenoid		Stinger	
Auxiliary Starter Solenoid Replacement	7-6	M1089 Stinger Does Not Operate	2-33
Fan and Differential Lock Solenoids		M1089 Stinger/Telescopic Lift Cylinders/	
Replacement	7-24	Fold Cylinder/Right 30K Winch Do	
Spare		Not Operate	2-33
Tire Retainer Does Not Lower	2-36	Storage	
Tire Retainer Does Not Raise	2-36	Preparation for Storage or Shipment	2-48
Special Purpose Kit Troubleshooting	2-34	Preparation for Storage or Shipment	
		Introduction	2-47

Subject Para

S (Cont)

Storage Maintenance Procedures 2-49

Suspension

 System Troubleshooting 2-28

 Will Not Compress or Return to Normal 2-31

Switch

 Dimmer Switch Replacement 7-12

 M1089 Wrecker Control Panel Toggle

 Switch Replacement 7-34

 M1090/M1094 Dump Body Switch

 Replacement/Adjustment 7-23

 Main Light Switch Replacement 7-17

 Oil Pressure Switch Replacement 7-48

 Start Inhibit Pushbutton Switch

 Replacement 7-19

 Starter Pushbutton Switch

 Replacement 7-20

 Turn Signal Switch Replacement 7-26

 Water Temperature Switch

 Replacement 7-50

Switches

 Rocker Switches Replacement 7-18

System

 Dump Body Hydraulic System

 Troubleshooting 2-32

 Fuel System Bleeding 4-11

 Cooling System Maintenance

 Introduction 6-1

 Electrical System Maintenance

 Introduction 7-1

 Exhaust System Maintenance

 Introduction 5-1

 Fuel System Maintenance Introduction 4-1

 Steering Hydraulic System

 Troubleshooting 2-30

 Suspension System Troubleshooting 2-28

 Wrecker Hydraulic System

 Troubleshooting 2-33

 15K Self-Recovery Winch (SRW) System

 Troubleshooting 2-29

T

Tachometer Replacement 7-21

Taillight

 Composite Taillight Assembly

 Replacement/Repair 7-39

Tailpipe Replacement 5-4

Subject Para

T (Cont)

Tank

 Fuel Tank Replacement 4-8

 Radiator Overflow Tank and Bracket

 Replacement/Repair 6-3

Telescopic

 M1089 Stinger/Telescopic Lift Cylinders/
 Fold Cylinder/Right 30K Winch Do

 Not Operate 2-33

Temperature

 Coolant Temperature Gage Sensor

 Replacement 7-45

 Coolant Temperature Light Switch

 Replacement 7-22

 Water Temperature Switch

 Replacement 7-50

Tensioner

 M1089 LH or RH 30K Winch Cable

 Drum Tensioner Does Not Operate 2-37

Terminal

 M1089 Terminal Board Replacement 7-33

Tester

 Battery Tester Replacement 7-54

Thermostat

 Housing Replacement 6-6

 Replacement 6-5

Throttle

 Control Cable Replacement/Adjustment 4-18

 Control Lever Replacement 4-20

 Control Threaded Rod Replacement 4-19

 Hand Throttle Lever Replacement/
 Adjustment 4-17

 Position Sensor (TPS) Cable Assembly

 Replacement 4-16

Tilt

 Cab Tilt and Spare Tire Retainer

 Troubleshooting 2-36

 Cab Tilt, Spare Tire Retainer, and
 Suspension Compression Will

 Not Work 2-31

Tire

 Central Tire Inflation System (CTIS)

 Cable Assembly Replacement 7-60

 Central Tire Inflation System (CTIS)

 ECU Indicates No Fault But System

 Fails to Inflate or Deflate 2-24

 Central Tire Inflation System (CTIS)

 Troubleshooting 2-24

 CTIS Repeatedly Resumes Cycling

 30 Seconds After Indicator Lights

 Stop Flashing 2-24

SUBJECT INDEX (CONT)

Subject	Para	Subject	Para
T (Cont)		T (Cont)	
Tire (Cont)		Troubleshooting (Cont)	
Five Central Tire Inflation System (CTIS)		Suspension System Troubleshooting	2-28
Indicator Lights Flashing	2-24	Wrecker Hydraulic System	
Four CTIS Indicator Lights		Troubleshooting	2-33
Flashing	2-24	Wrecker Pneumatic Troubleshooting	2-37
Spare Tire Retainer Does Not Lower	2-36	Tube	
Spare Tire Retainer Does Not Raise	2-36	Turbocharger to Charge Air Cooler Tube	
Two Steady Mode Lights Illuminate on		and Hoses Replacement	4-4
Central Tire Inflation System (CTIS)		Coolant Bypass Tube Replacement	6-7
ECU	2-24	Fuel Ratio Control Tube Replacement	4-6
TPS		Intake Air Cleaner Filter Element, Air	
Throttle Position Sensor (TPS) Cable		Cleaner Assembly, and Particle Extraction	
Assembly Replacement	4-16	Tube Replacement	4-2
Trailer		Orifice Tube Assembly Replacement	4-5
Excessive Movement of Trailer King Pin		Upper Coolant Tube and Hoses	
In Fifth Wheel	2-27	Replacement	6-9
Transducer		Tubes	
Oil Pressure Transducer Replacement	7-49	Charge Air Cooler to Air Inlet Elbow	
Transmission		Tubes and Hoses Replacement	4-5
Engine and Transmission Oil Sampling		Turbocharger to Charge Air Cooler Tube	
Valves Replacement	3-6	and Hoses Replacement	4-4
Engine Speed Sensor Replacement	7-52	Turn Signal Switch Replacement	7-26
WTEC II Transmission ECU Pushbutton		Two	
Shift Selector (TEPSS) Dimmer Module		Steady Mode Lights Illuminate on	
Replacement	7-13	Central Tire Inflation System (CTIS)	
Transmitter		ECU	2-24
Air Pressure Transmitter Replacement	7-44		
Transport/Transportability		U	
Air Transport Troubleshooting	2-31	Underlift	
Troop Transport Alarm Does Not		M1089 Underlift Telescopic Lift	
Operate	2-31	Cylinder(s) Does Not Operate	2-33
Troop		Upper Coolant Tube and Hoses	
Transport Alarm Does Not Operate	2-31	Replacement	6-9
Troubleshooting		V	
15K Self-Recovery Winch (SRW) System		Valve	
Troubleshooting	2-29	Cover Replacement	3-3
Axle Troubleshooting	2-25	Fuel Pressure Regulating Valve	
Dump Body Hydraulic System		Replacement	4-3
Troubleshooting	2-32	Voltage	
Fifth Wheel Troubleshooting	2-27	100 Amp Voltage Regulator	
M1084/M1086 Material Handling Crane		Replacement	7-5
(MHC) Hydraulic Troubleshooting	2-35		
Special Purpose Kit Troubleshooting	2-34		
Steering Hydraulic System			
Troubleshooting	2-30		
Steering Troubleshooting	2-26		

Subject	Para
W	
Wanders,	
Pulls to One Side, or	
Shimmies	2-26
Pulls to One Side, or	
Shimmies	2-28
Warning	
No Overspeed Warning Light and/or	
Overspeed Pressure Change	2-24
Washer	
Windshield Washer Pump Electromagnetic	
Interference (EMI) Cable Assembly	
Replacement	7-67
Water	
Fuel/Water Separator and Filter	
Replacement	4-13
Pump and Fittings Replacement	6-12
Temperature Switch Replacement	7-50
Wheel	
Fifth Wheel Troubleshooting	2-27
Fifth Wheel Will Not Lock When Coupling	
Trailer to Tractor	2-27
Fifth Wheel Will Not Unlock When	
Disconnecting Trailer From Tractor	2-27
No Response When Turning Steering	
Wheel	2-26
Winch	
M1089 LH or RH 30K Winch Cable	
Drum Tensioner Does Not Operate	2-37
M1089 LH or RH 30K Winch Does	
Not Pay-In	2-37
M1089 RH 30K Winch Does Not Operate . . .	2-33
M1089 Stifflegs/Left 30K Winch/15K	
Self-Recovery Winch (SRW) Do Not	
Operate	2-33
M1089 Stinger/Telescopic Lift Cylinders/	
Fold Cylinder/Right 30K Winch Do	
Not Operate	2-33
15K Self-Recovery Winch (SRW) System	
Troubleshooting	2-29
15K Self-Recovery Winch (SRW) Will	
Not Work	2-29
Main Winch LH Freespool Does Not	
Operate	2-37
Main Winch RH Freespool Does Not	
Operate	2-37
Main Winch LH or RH Freespool(s)	
Does Not Operate	2-37

Subject	Para
W (Cont)	
Windshield	
Washer Pump Electromagnetic Interference	
(EMI) Cable Assembly Replacement	7-67
Wiper ECU Replacement	7-69
Wiper Electromagnetic Interference	
(EMI) Cable Replacement	7-68
Wiper	
Windshield Wiper ECU Replacement	7-69
Windshield Wiper Electromagnetic	
Interference (EMI) Cable	
Replacement	7-68
Worklight	
M1088/M1089 Stationary Worklight	
Assembly Replacement/Repair	7-42
Wrecker	
Hydraulic System Troubleshooting	2-33
M1089 Wrecker Control Panel Toggle	
Switch Replacement	7-34
M1089 Wrecker Remote Control Box	
Repair	7-35
One Wrecker Function Does Not Operate	
From Wrecker Remote Control	2-37
Pneumatic Troubleshooting	2-37

GLOSSARY ABBREVIATIONS

ANSI	American National Standards Institute
CCW	Counterclockwise
CTIS	Central Tire Inflation System
CW	Clockwise
ECU	Electronic Control Unit
EMI	Electromagnetic Interference
LED	Light Emitting Diode
LH	Left Hand
LMHC	Light Material Handling Crane
MAC	Maintenance Allocation Chart
MHC	Material Handling Crane
NATO	North Atlantic Treaty Organization
NBC	Nuclear, Biological, or Chemical
NO/NC	Normally Open/Normally Closed
O/R	Outrigger
PDP	Power Distribution Panel
PMCS	Preventive Maintenance Checks and Services
PTO	Power Takeoff
RH	Right Hand
SAE	Society of Automotive Engineers
SRW	Self-Recovery Winch
STE/ICE-R	Simplified Test Equipment/Internal Combustion Engine-Reprogrammable
TEPSS	Transmission ECU Pushbutton Shift Selector
TM	Technical Manual
TPS	Throttle Position Sensor

GLOSSARY ABBREVIATIONS (CONT)

TPSS	Transmission Pushbutton Shift Selector
VDC	Volts Direct Current
VIM	Vehicle Interface Module
WTEC II	World Transmission Electronic Controls (version 2)
WTEC III	World Transmission Electronic Controls (version 3)

By Order of the Secretary of the Army:

Official:



Handwritten signature of Joel B. Hudson in black ink.

JOEL B. HUDSON

*Administrative Assistant to the
Secretary of the Army*
05127

DENNIS J. REIMER
General, United States Army
Chief of Staff

DISTRIBUTION: To be distributed in accordance with the initial distribution number (IDN) 380940, requirements for TM 9-2320-366-20-3.

	1	2	3	4	5	6	7	8	9
A									
B									
C									
D									
E									
F									
G									
H									
	1	2	3	4	5	6	7	8	9

FIGURE FO-1 ELECTRICAL SYSTEM SCHEMATIC
 FOLDOUT 1 OF 40
 SIZE B ILL. NO. 6WD01L1B FP-1/ (FP-2 BLANK)

10				11				12				13				14				15				16				17				18			
CONNECTORS				CONNECTORS (CONTINUED)				CONNECTORS (CONTINUED)				CONNECTORS (CONTINUED)				CONNECTORS (CONTINUED)				CONNECTORS (CONTINUED)				CONNECTORS (CONTINUED)											
NUMBER	ZONE	SH	DESCRIPTION	NUMBER	ZONE	SH	DESCRIPTION	NUMBER	ZONE	SH	DESCRIPTION	NUMBER	ZONE	SH	DESCRIPTION	NUMBER	ZONE	SH	DESCRIPTION	NUMBER	ZONE	SH	DESCRIPTION	NUMBER	ZONE	SH	DESCRIPTION	NUMBER	ZONE	SH	DESCRIPTION				
CABLE A	G315	35	OVERLOAD SHUTDOWN SYSTEM	J52	B239	27	CHASSIS - FRONT	P8	B47	6	BLACKOUT MARKER RIGHT FRONT	P60	E242	27	MIDDLE FRONT TOP CLEARANCE LIGHT	P85	A233	26	LH SIDE MARKER LIGHT																
CABLE A	D317	36	WRECKER MATERIAL HANDLING CRANE	J53	F236	27	AIRDROP ONLY	P9	C47	6	FRONT RIGHT TURN SIGNAL	P61	E215	24	RH COMPOSITE LIGHT	P86	A206	23	LH REAR MARKER LIGHT																
CABLE A	F324	36	OVERLOAD SHUTDOWN SYSTEM	J55	C94	11	CAB MARKER LIGHT FRONT UPPER RIGHT	P10	B47	6	PARKING LIGHT FRONT RIGHT	P61	F206	23	RH COMPOSITE LIGHT	P86	A215	24	LH REAR MARKER LIGHT																
CABLE A	D340	38	WRECKER CONTROLS	J57	D94	11	CAB MARKER LIGHT FRONT UPPER MIDDLE LEFT	P12	D47	6	RIGHT HEADLIGHT	P61	F224	25	RH COMPOSITE LIGHT	P86	A224	25	LH REAR MARKER LIGHT																
CABLE B	A307	35	CARGO MATERIAL HANDLING CRANE	J59	C94	11	CAB MARKER LIGHT FRONT UPPER MIDDLE RIGHT	P13	C47	6	RIGHT HEADLIGHT	P61	F233	26	RH COMPOSITE LIGHT	P86	A233	26	LH REAR MARKER LIGHT																
CABLE C	G308	35	CARGO MATERIAL HANDLING CRANE	J60	D94	11	CAB MARKER LIGHT FRONT UPPER MIDDLE MIDDLE	P14	C47	6	RIGHT HEADLIGHT	P62	D215	24	RH COMPOSITE LIGHT	P87	C206	23	BACKUP LIGHT																
CABLE F	B308	36	INTERNAL REMOTE CONNECTOR	J62	E97	11	ROTARY WARNING LIGHT CONNECTOR	P17	H47	6	BLACKOUT DRIVE LIGHT	P62	F206	23	RH COMPOSITE LIGHT	P87	B215	24	BACKUP LIGHT																
CABLE G	F299	35	CARGO MATERIAL HANDLING CRANE	J65	E195	22	ROTARY WARNING LIGHT CONNECTOR	P18	D47	6	LEFT HEADLIGHT	P62	F224	25	RH COMPOSITE LIGHT	P87	C224	25	BACKUP LIGHT																
CABLE G	A324	36	INTERNAL REMOTE CONTROL CONNECTOR	J78	F194	22	CAB RADIO CONNECTOR	P18	A186	21	CAB - DASH - LEFT - UNDERDASH	P62A	F233	26	RH COMPOSITE LIGHT	P87	C233	26	BACKUP LIGHT																
CABLE H	F304	35	CRANE CONTROL PANEL	J80	A299	34	AIR DRYER CONNECTOR	P19	E47	6	LEFT HEADLIGHT	P63	B236	27	ROTARY WARNING LIGHT CONNECTOR	P88	G206	23	RH SIDE MARKER LIGHT																
CABLE H	E313	36	CRANE CONTROL PANEL	J80	D87	10	AIR DRYER (EXCEPT DUMP)	P20	D47	6	LEFT HEADLIGHT	P63	F224	25	RH COMPOSITE LIGHT	P88	H224	25	RH SIDE MARKER LIGHT																
CABLE I	G313	35	CRANE CONTROL PANEL	J80	D87	10	AIR DRYER (EXCEPT DUMP)	P22	G47	6	PARKING LIGHT FRONT LEFT	P63	G206	23	RH COMPOSITE LIGHT	P88	H233	26	RH SIDE MARKER LIGHT																
CABLE I	F322	36	CRANE CONTROL PANEL	J93	B59	7	CHASSIS - SPARE TIRE	P23	F47	6	FRONT LEFT TURN SIGNAL	P63	D215	24	RH COMPOSITE LIGHT	P89	G206	23	RH REAR MARKER LIGHT																
CABLE J	G313	35	CRANE CONTROL PANEL	J95	E47	6	12V INTERVEHICULAR	P24	H47	6	BLACKOUT MARKER LEFT FRONT	P63	G233	26	RH COMPOSITE LIGHT	P89	C215	24	RH REAR MARKER LIGHT																
CABLE J	F322	36	CRANE CONTROL PANEL	J95	E47	6	12V INTERVEHICULAR	P25	G94	11	WINDSHIELD WASHER ROTARY PUMP (B3)	P64	F206	23	RH COMPOSITE LIGHT	P89	G224	25	RH REAR MARKER LIGHT																
CABLE K	G304	35	CRANE CONTROL PANEL	J99	E196	22	CHEMICAL ALARM CONNECTOR	P25	B300	34	DUMP BED SWITCH CONNECTOR	P64	F224	25	RH COMPOSITE LIGHT	P89	G233	26	RH REAR MARKER LIGHT																
CABLE K	F322	36	CRANE CONTROL PANEL	J106	F59	7	CHEMICAL DETECTOR RECEPTACLE	P27	A52	6	CHASSIS - FRONT	P64	D215	24	RH COMPOSITE LIGHT	P107	B199	23	WRECKER REAR LIGHTS																
CABLE L	D304	35	CRANE CONTROL PANEL	J108	B258	29	CAB - DASH - CENTER - OPTIONS PANEL	P31	E65	8	ENGINE	P64	F233	26	RH COMPOSITE LIGHT	P108	B258	29	CAB - DASH - CENTER - OPTIONS PANEL																
CABLE L	C322	36	CRANE CONTROL PANEL	J111	E131	15	CTIS ELECTRONIC CONTROL UNIT	P31X	D65	8	ENGINE	P65	E195	22	ROTARY WARNING LIGHT CONNECTOR	P108	F199	23	WRECKER REAR LIGHTS																
CABLE M	D313	35	CRANE CONTROL PANEL	J113	G195	22	CTIS PRESSURE TRANSDUCER	P32	F68	8	ENGINE OIL PRESSURE SENSOR	P67	A83	10	PRE-BLOCK SEVEN WITH PIGTAIL TRANSMISSION EXTERNAL WIRING HARNESS TO TRANSMISSION CONNECTOR	P110	E128	15	CTIS ELECTRONIC CONTROL UNIT																
CABLE M	C322	36	CRANE CONTROL PANEL	J114	B173	20	CAB - DASH - LEFT - TRANSMISSION HARNESS - WTEC II	P33	H68	8	FUEL/WATER SEPARATOR	P67	B78	9	TID1, TID2, AND TID3 TRANSMISSION EXTERNAL WIRING HARNESS TO TRANSMISSION CONNECTOR	P111	E131	15	CTIS ELECTRONIC CONTROL UNIT																
CABLE N	D313	35	CRANE CONTROL PANEL	J114	C353	40	WTEC III CAB TRANSMISSION HARNESS (TID1) CONNECTOR	P34	E68	8	OIL PRESSURE WARNING LIGHT SWITCH	P69	D68	8	ENGINE	P112	G132	15	CAB - DASH - CENTER - HEATER/CTIS ECU																
CABLE N	D322	36	CRANE CONTROL PANEL	J114	C357	40	WTEC III CAB TRANSMISSION HARNESS (TID2) CONNECTOR	P36	A66	8	WATER COOLER TEMPERATURE	P71	E75	9	PRE-BLOCK SEVEN TRANSMISSION OUTPUT SPEED SENSOR CONNECTOR	P113	F132	15	CTIS ELECTRONIC CONTROL UNIT																
CABLE O	C313	35	CRANE CONTROL PANEL	J115	C163	19	CAB - DASH - LEFT - WTEC III TRANSMISSION HARNESS	P37	C66	8	WATER TEMPERATURE SWITCH	P71	E79	9	TID1, TID2, AND TID3 TRANSMISSION OUTPUT SPEED SENSOR CONNECTOR	P114	C350	39	WTEC III CAB TRANSMISSION HARNESS (TID2)																
CABLE O	G322	36	CRANE CONTROL PANEL	J115	C346	39	WTEC III TRANSMISSION ECU CONNECTOR	P38	F70	8	ENGINE SPEED MAGNETIC PICKUP	P71	E83	10	PRE-BLOCK SEVEN WITH PIGTAIL TRANSMISSION OUTPUT SPEED SENSOR CONNECTOR	P115	C346	39	WTEC III CAB - DASH - RIGHT - KICK PANEL																
CABLE P	C313	35	CRANE CONTROL PANEL	J116	C168	19	CAB - DASH - LEFT - WTEC III TRANSMISSION HARNESS	P39	G70	8	ENGINE	P72	E83	10	PRE-BLOCK SEVEN WITH PIGTAIL TRANSMISSION THROTTLE POSITION SENSOR CONNECTOR	P116	E346	39	WTEC III CAB - DASH - RIGHT - KICK PANEL																
CABLE P	C322	36	CRANE CONTROL PANEL	J116	E346	39	WTEC III TRANSMISSION ECU CONNECTOR	P41	B66	8	WATER TEMPERATURE SENSOR	P72	F75	9	PRE-BLOCK SEVEN TRANSMISSION ENGINE SPEED SENSOR CONNECTOR	P116	C194	22	CAB - DASH - RIGHT - UNDERDASH WTEC II																
CABLE Q	E313	35	CRANE CONTROL PANEL	J117	F170	19	CAB - DASH - LEFT - WTEC III TRANSMISSION HARNESS	P42	F66	8	ETHER SENSOR SWITCH	P72	F79	9	TID1, TID2, AND TID3 TRANSMISSION ENGINE SPEED SENSOR CONNECTOR	P118	D170	19	CAB - DASH - LEFT - TRANSMISSION HARNESS																
CABLE Q	E322	36	CRANE CONTROL PANEL	J118	D170	19	CAB - DASH - LEFT - WTEC III TRANSMISSION HARNESS	P43	G51	6	CHASSIS - FRONT	P73	F75	9	PRE-BLOCK SEVEN TRANSMISSION THROTTLE POSITION SENSOR CONNECTOR	P119	B178	20	CAB - DASH - LEFT - TRANSMISSION HARNESS																
CABLE R	E313	35	CRANE CONTROL PANEL	J119	B178	20	CAB - DASH - LEFT - TRANSMISSION HARNESS	P43X	F51	6	CHASSIS - FRONT	P73	F79	9	TID1, TID2, AND TID3 TRANSMISSION THROTTLE POSITION SENSOR CONNECTOR	P119	D73	9	PRE-BLOCK SEVEN TRANSMISSION CONNECTOR																
CABLE R	D322	36	CRANE CONTROL PANEL	J119	C355	40	WTEC III CAB TRANSMISSION HARNESS (TID1)	P50	E94	11	CAB MARKER LIGHT FRONT UPPER LEFT	P73	F83	10	PRE-BLOCK SEVEN WITH PIGTAIL TRANSMISSION THROTTLE POSITION SENSOR CONNECTOR	P119	D78	9	TID1, TID2, AND TID3 TRANSMISSION CONNECTOR																
CABLE S	F313	35	CRANE CONTROL PANEL	J119	C359	40	WTEC III CAB TRANSMISSION HARNESS (TID2)	P50	F242	27	LH FRONT TOP CAB MARKER LIGHT	P74	A215	24	LH COMPOSITE LIGHT	P119	D82	10	PRE-BLOCK SEVEN WITH PIGTAIL TRANSMISSION CONNECTOR																
CABLE S	E322	36	CRANE CONTROL PANEL	J129	F94	11	CAB MARKER LIGHT FRONT LOWER LEFT	P51	D199	23	CAB - DASH - RIGHT - POWER DISTRIBUTION PANEL	P74	B206	23	LH COMPOSITE LIGHT	P125	G83	11	WINDSHIELD WASHER ROTARY PUMP (B3)																
CABLE T	F313	35	CRANE CONTROL PANEL	J130	F94	11	CAB MARKER LIGHT LEFT DOOR	P51	D208	24	REAR LIGHTS TRACTOR	P74	B224	25	LH COMPOSITE LIGHT	P129	F94	11	CAB MARKER LIGHT FRONT LOWER LEFT																
CABLE T	E322	36	CRANE CONTROL PANEL	J130	F238	27	12 PIN CONNECTOR	P51	D226	26	CAB - DASH - RIGHT - POWER DISTRIBUTION PANEL	P74	B233	26	LH COMPOSITE LIGHT	P130	F94	11	CAB MARKER LIGHT LEFT DOOR																
CABLE U	A314	35	CRANE REMOTE CONNECTOR	J131	B94	11	CAB MARKER LIGHT RIGHT DOOR	P52M	G208	24	REAR LIGHTS TRACTOR	P74	B233	26	LH COMPOSITE LIGHT	P131	A94	11	CAB MARKER LIGHT RIGHT DOOR																
CABLE V	E313	35	CRANE CONTROL PANEL	J132	B94	11	CAB MARKER LIGHT FRONT LOWER RIGHT	P52R	E205	23	WRECKER REAR LIGHTS	P74	B233	26	LH COMPOSITE LIGHT	P132	B94	11	CAB MARKER LIGHT FRONT LOWER RIGHT																
CONN F	C335	38	WRECKER REMOTE	J172	A300	34	DUMP BODY CONNECTOR	P52R	G214	24	REAR LIGHTS TRACTOR	P74	B233	26	LH COMPOSITE LIGHT	P133	A199	23	LH WORKLIGHTS																
CONN G	C340	38	WRECKER REMOTE	J209	F265	30	ALL MTV W/O PTO	P52R	E223	25	LONG WHEEL BASE	P74	B206	23	LH COMPOSITE LIGHT	P133	B209	24	LH WORKLIGHTS																
J2	A194	22	EMI FILTER	J209	G265	30	DUMP, CARGO LWB, CARGO W/MHC, CARGO LWB W/MHC	P52R	E232	26	ALL MODELS EXCEPT WRECKER, TRACTOR, AND LONG WHEEL BASE	P76	B206	23	LH COMPOSITE LIGHT	P133A	B199	23	LH WORKLIGHTS																
J3	D241	27	AIRDROP ONLY	J209A	G267	30	TRACTOR W/O WINCH	P53M	F208	24	REAR LIGHTS TRACTOR	P76	B224	25	LH COMPOSITE LIGHT	P133A	B209	24	LH WORKLIGHTS																
J4	E340	38	WRECKER CONTROLS	J209A	C266	30	PTO EQUIPPED	P53R	D205	23	WRECKER REAR LIGHTS	P76	B224	25	LH COMPOSITE LIGHT	P134	G199	23	RH WORKLIGHTS																
J5	A47	6	VEHICLE HORN	J209B	F267	30	TRANSMISSION AUXILIARY OIL COOLER FAN	P53R	F214	24	REAR LIGHTS TRACTOR	P76	B215	24	LH COMPOSITE LIGHT	P134	C209	24	RH WORKLIGHTS																
J6	A47	6	VEHICLE HORN	J209B	D266	30	PTO EQUIPPED	P53R	D223	25	LONG WHEEL BASE	P76	B233	26	LH COMPOSITE LIGHT	P134A	F199	23	RH WORKLIGHTS																
J7	A197	22	WTEC II TRANSMISSION PUSHBUTTON SHIFT SELECTOR DIMMER MODULE	J210	F258	29	CAB - DASH - CENTER - OPTIONS PANEL	P53R	D232	26	ALL MODELS EXCEPT WRECKER, TRACTOR, AND LONG WHEEL BASE	P76	B233	26	LH COMPOSITE LIGHT	P134A	B209	24	RH WORKLIGHTS																
J8	B47	6	BLACKOUT MARKER LIGHT FRONT	J215	E266	30	PTO EQUIPPED	P54	D206	23	LEFT REAR MARKER	P76	B224	25	LH COMPOSITE LIGHT	P135	D260	29	CAB - DASH - CENTER - OPTIONS PANEL																
J9	C47	6	FRONT RIGHT TURN SIGNAL	J912	B133	15	CAB - DASH - CENTER - HEATER/CTIS ECU	P54	F215	24	LEFT REAR MARKER	P76	B224	25	LH COMPOSITE LIGHT	P136	C260	29	CAB - DASH - CENTER - OPTIONS PANEL																
J10	B47	6	PARKING LIGHT FRONT RIGHT	J912	D245	28	CAB - DASH - CENTER - OPTIONS PANEL	P54	D224	25	LEFT REAR MARKER	P76	B233	26	LH COMPOSITE LIGHT	P171	F308	35	CARGO MATERIAL HANDLING CRANE																
J12	D47	6	RIGHT HEADLIGHT	J912	G264	30	ALL MTV W/O PTO	P54	D233	26	LEFT REAR MARKER	P76	B233	26	LH COMPOSITE LIGHT	P72	A300	34	DUMP BODY CONNECTOR																
J13	C47	6	RIGHT HEADLIGHT	J912	F265	30	TRACTOR W/O WINCH	P55	C94	11	CAB MARKER LIGHT FRONT UPPER RIGHT	P76	B206	23	LH COMPOSITE LIGHT	P201	G70	8	ENGINE																
J14	C47	6	RIGHT HEADLIGHT	J912	F265	30	DUMP, CARGO LWB, CARGO W/MHC, CARGO LWB W/MHC	P55	D242	27	RH FRONT TOP CAB MARKER LIGHT	P76	B215	24	LH COMPOSITE LIGHT	P209A	F268	30	TRANSMISSION AUXILIARY OIL COOLER FAN																
J17	H47	6	BLACKOUT DRIVE LIGHT	J921	G70	8	TROOP TRANSPORT ALARM	P56	D206	23	MIDDLE REAR MARKER	P76	B224	25	LH COMPOSITE LIGHT	P209B	G264	30	DUMP, CARGO LWB, CARGO W/MHC, CARGO LWB W/MHC																
J18	D47	6	LEFT HEADLIGHT	L4	E268	30	WINCH IN SOLENOID	P56	E224	25	MIDDLE REAR MARKER	P77	C206	23	LH COMPOSITE LIGHT	P209B	G268	30	TRANSMISSION AUXILIARY OIL COOLER FAN																
J19	E47	6	LEFT HEADLIGHT	L5	D268	30	WINCH OUT SOLENOID	P56	F215	24	MIDDLE REAR MARKER	P77	C224	25	LH COMPOSITE LIGHT	P210	F258	29	CAB - DASH - CENTER - OPTIONS PANEL																
J19	C186	21	CAB - DASH - LEFT - UNDERDASH	L7	B301	34	TAILGATE RELEASE CONNECTOR	P56	E233	26	MIDDLE REAR MARKER	P77	C233	26	LH COMPOSITE LIGHT	P210	C263	30	PTO EQUIPPED																
J20	D47	6	LEFT HEADLIGHT	L8	B301	34	DUMP BED DOWN CONNECTOR	P57	D94	11	CAB MARKER LIGHT FRONT UPPER MIDDLE LEFT	P78	B206	23	LH COMPOSITE LIGHT	P215	E266	30	PTO EQUIPPED																
J22	G47	6	PARKING LIGHT FRONT LEFT	L9	A301	34	DUMP BED DOWN CONNECTOR	P57	F242	27	LH FRONT TOP CAB CLEARANCE LIGHT	P78	B215	24	LH COMPOSITE LIGHT	P216	E265	30	PTO EQUIPPED																
J23	F47	6	FRONT LEFT TURN SIGNAL	P2	A194	22	EMI FILTER	P58	E206	23	RIGHT REAR MARKER	P78	B224	25	LH COMPOSITE LIGHT	P216	A304	34	PTO PRESSURE SWITCH CONNECTOR																
J24	H47	6	BLACKOUT MARKER LEFT FRONT	P3	D240	27	AIRDROP ONLY	P58	E215	24	RIGHT REAR MARKER	P78	B215	24	LH COMPOSITE LIGHT	P217	C265	30	PTO EQUIPPED																
J25	G94	11	WINDSHIELD WASHER ROTARY PUMP (B3)	P5	A47	6	VEHICLE HORN	P58	E224	25	RIGHT REAR MARKER	P78	B224	25	LH COMPOSITE LIGHT	P217	C265	30	PTO EQUIPPED																
J27	A52	6	CHASSIS - FRONT	P6	A47	6	VEHICLE HORN	P58	E233	26	RIGHT REAR MARKER	P78	B233	26	LH COMPOSITE LIGHT	P217	C265	30	PTO EQUIPPED																
J31	E65	8	ENGINE	J43	C51	6	CHASSIS - FRONT	P59	C94	11	CAB MARKER LIGHT FRONT UPPER MIDDLE RIGHT	P78	B233	26	LH COMPOSITE LIGHT	P217	C265	30	PTO EQUIPPED																
J31X	F184	21	CAB - DASH - LEFT - UNDERDASH	J43X	F51	6	CHASSIS - FRONT	P59	D242	27	RH FRONT TOP CAB CLEARANCE LIGHT	P80	G60	7	CHASSIS - REAR	P217	C265	30	PTO EQUIPPED																
J39	G70	8	ENGINE	J43X	G184	21	CAB - DASH - LEFT - UNDERDASH	P59	D242	27	RH FRONT TOP CAB CLEARANCE LIGHT	P80B	A298	34	AIR DRYER CONNECTOR (DUMP)	P217	C265	30	PTO EQUIPPED																
J43	C51	6	CHASSIS - FRONT	J44	B238	27	ROTARY WARNING LIGHT CONNECTOR	P59	D242	27	RH FRONT TOP CAB CLEARANCE LIGHT	P80B	A298	34	AIR DRYER CONNECTOR (DUMP)	P217	C265	30	PTO EQUIPPED																
J43X	F51	6	CHASSIS - FRONT	J45	C238	27	ROTARY WARNING LIGHT CONNECTOR	P60	D94	11	CAB MARKER LIGHT FRONT UPPER MIDDLE MIDDLE	P81	C56	7	CHASSIS - FRONT	P217	C265	30	PTO EQUIPPED																
J43X	G184	21	CAB - DASH - LEFT - UNDERDASH	J50	E94	11	CAB MARKER LIGHT FRONT UPPER LEFT	P60	D94	11	CAB MARKER LIGHT FRONT UPPER MIDDLE MIDDLE	P81	D71	8	STARTER THERMO SWITCH	P217	C265	30	PTO EQUIPPED																
J44	B238	27	ROTARY WARNING LIGHT CONNECTOR	J51	D51	6	CHASSIS - FRONT	P60	D94	11	CAB MARKER LIGHT FRONT UPPER MIDDLE MIDDLE	P82	B60	7	FUEL TANK LEVEL SENSOR	P217	C265	30	PTO EQUIPPED																
J45	C238	27	ROTARY WARNING LIGHT CONNECTOR	J52	E47	6	CHASSIS - FRONT BUMPER	P60																											

	19			20			21			22			23			24			25			26			27										
A	CONNECTORS (CONTINUED)						LIGHTS (CONTINUED)						LIGHTS (CONTINUED)						CIRCUIT BREAKERS (CONTINUED)						TERMINAL LUGS (CONTINUED)										
	NUMBER	ZONE	SH	DESCRIPTION			NUMBER	ZONE	SH	DESCRIPTION			NUMBER	ZONE	SH	DESCRIPTION			NUMBER	ZONE	SH	DESCRIPTION			NUMBER	ZONE	SH	DESCRIPTION			NUMBER	ZONE	SH	DESCRIPTION	
B	P905A	B247	28	CAB - DASH - CENTER - OPTIONS PANEL			DS16	E110	13	HIGH BEAM			DS53	H46	6	BLACKOUT DRIVE LIGHT			CB22	C158	18	FAN/ETHER			TL7	C233	26	BACKUP LIGHT							
	P906	A248	28	CAB - DASH - CENTER - OPTIONS PANEL			DS17	D128	15	HEATER CONTROL PANEL ILLUMINATION			DS54	D93	11	CAB MARKER LIGHT FRONT UPPER MIDDLE LEFT			CB23	C156	18	HEATER BLOWER			TL17	C206	23	WRECKER REAR LIGHTS							
	P906A	B248	28	CAB - DASH - CENTER - OPTIONS PANEL			DS18	A244	28	CAB - DASH - CENTER - OPTIONS PANEL			DS54	F242	27	LH FRONT TOP CAB CLEARANCE LIGHT			CB30	C148	17	CHEMICAL ALARM			TL17	C215	24	REAR LIGHTS TRACTOR							
	P908	A251	28	CAB - DASH - CENTER - OPTIONS PANEL			DS19	E110	13	RADIATOR FAN OFF			DS55	D93	11	CAB MARKER LIGHT FRONT UPPER MIDDLE MIDDLE			CB35	D158	18	WTEC II VIM POWER			TL17	C224	25	LONG WHEEL BASE							
	P908A	B251	28	CAB - DASH - CENTER - OPTIONS PANEL			DS21	C110	13	EMERGENCY BRAKE			DS55	E242	27	MIDDLE FRONT TOP CLEARANCE LIGHT			CB36	C156	18	HORN POWER			TL18	C206	23	WRECKER REAR LIGHTS							
	P909	A256	29	CAB - DASH - CENTER - OPTIONS PANEL			DS22	D110	13	PARKING BRAKE			DS56	C93	11	CAB MARKER LIGHT FRONT UPPER MIDDLE RIGHT			CB37	C160	18	WINDSHIELD WIPER/WASHER			TL18	H215	24	REAR LIGHTS TRACTOR							
	P909A	B256	29	CAB - DASH - CENTER - OPTIONS PANEL			DS23	C110	13	PTO ON			DS56	D242	27	RH FRONT TOP CAB CLEARANCE LIGHT			CB38	D156	18	ROTATING BEACON			TL18	C224	25	LONG WHEEL BASE REAR LIGHTS							
	P910	B251	28	CAB - DASH - CENTER - OPTIONS PANEL			DS24	D110	13	OIL PRESSURE			DS57	C93	11	CAB MARKER LIGHT FRONT UPPER RIGHT			CB39	C155	18	TRAILER BLACKOUT STOP			TL18	C233	26	LONG WHEEL BASE							
	P910A	D251	28	CAB - DASH - CENTER - OPTIONS PANEL			DS25	C110	13	WATER TEMPERATURE			DS57	D242	27	RH FRONT TOP CAB MARKER LIGHT			CB40	C159	18	CTIS COOLER			TL19	H206	23	WRECKER REAR LIGHTS							
	P911	B256	29	CAB - DASH - CENTER - OPTIONS PANEL			DS27	C110	13	REAR BRAKE AIR			DS58	E93	11	CAB MARKER LIGHT FRONT UPPER LEFT			CB41	C151	17	TRAILER REAR LIGHTS POWER			TL19	H224	25	LONG WHEEL BASE							
C	P911A	D256	29	CAB - DASH - CENTER - OPTIONS PANEL			DS28	E110	13	FRONT AIR BRAKE			DS58	F242	27	LH FRONT TOP CAB MARKER LIGHT			CB42	C151	17	BLACKOUT MARKER LIGHTS POWER			TL19	H233	26	RH SIDE MARKER LIGHT							
	P912	B133	15	CAB - DASH - CENTER - HEATER/CTIS - ECU			DS29	D110	13	ENGINE OIL LEVEL			DS59	B93	11	CAB MARKER LIGHT RIGHT DOOR			CB43	C152	17	REAR COMPOSITE LIGHTS / WTEC III ECU			TL20	G233	26	RH REAR MARKER LIGHT							
	P912A	F134	15	CAB - DASH - CENTER - HEATER/CTIS - ECU			DS30	F110	13	MASTER STOP			DS60	F93	11	CAB MARKER LIGHT FRONT LOWER LEFT			CB44	C152	17	REAR COMPOSITE LIGHTS			TL20	C215	24	TRACTOR REAR LIGHTS							
	P913	B131	15	CAB - DASH - CENTER - HEATER/CTIS - ECU			DS31	D249	28	TRACTOR BLACKOUT CENTER - OPTIONS PANEL			DS61	A93	11	CAB MARKER LIGHT RIGHT DOOR			CB45	C148	17	FUEL PREHEAT			TL20	G224	25	LONG WHEELBASE REAR LIGHTS							
	P913	F245	28	CAB - DASH - CENTER - OPTIONS PANEL			DS32	B110	13	CHEMICAL DETECT			DS62	F93	11	CAB MARKER LIGHT LEFT DOOR			CB48	C149	17	ARCTIC CAB/ENGINE KILL			TL20	G206	23	WRECKER REAR LIGHTS							
	P914	A250	28	CAB - DASH - CENTER - OPTIONS PANEL			DS34	C110	13	CTIS OVERSPEED			DS63	B246	28	CAB - DASH - CENTER - OPTIONS PANEL			CB49	C160	18	PTO POWER			TL21	G206	23	WRECKER REAR LIGHTS							
	P914A	B250	28	CAB - DASH - CENTER - OPTIONS PANEL			DS35	C207	23	WRECKER BLACKOUT STOP LEFT REAR			DS64	B248	28	CAB - DASH - CENTER - OPTIONS PANEL			CB50	C155	18	SWINGFIRE PUMP POWER			TL21	D215	24	REAR LIGHTS TRACTOR							
	P921	G70	8	TROOP TRANSPORT ALARM			DS35	B216	24	TRACTOR BLACKOUT STOP LEFT REAR			DS65	A207	23	WRECKER LH SIDE MARKER LIGHT			CB53	D149	17	CAB - DASH - RIGHT - POWER DISTRIBUTION PNL			TL21	G224	25	LONG WHEEL BASE							
	P94	A199	23	LH INTERMEDIATE MARKER			DS35	C225	25	LONG WHEEL BASE BLACKOUT STOP LEFT REAR			DS65	A225	25	LONG WHEEL BASE LH SIDE MARKER LIGHT			CB54	D151	17	BLACKOUT HEADLIGHT			TL21	G233	26	RH COMPOSITE LIGHT							
	P94	A217	25	LH INTERMEDIATE MARKER			DS35	C234	26	ALL MODELS EXCEPT WRECKER, TRACTOR, AND LONG WHEEL BASE BLACKOUT STOP LEFT REAR			DS66	A207	23	WRECKER LH REAR MARKER LIGHT			CB61	D162	18	CAB - DASH - RIGHT - POWER DISTRIBUTION PNL			TL22	D94	11	CAB MARKER LIGHTS							
P95	G199	23	RH INTERMEDIATE MARKER			DS66							A216	24	TRACTOR LH REAR MARKER LIGHT			CB62	D162	18	CAB - DASH - RIGHT - POWER DISTRIBUTION PNL			TL22	E242	27	LH FRONT TOP CAB CLEARANCE LIGHT								
P95	G217	25	RH INTERMEDIATE MARKER			DS66							A225	25	LONG WHEEL BASE LH REAR MARKER LIGHT			CB63	D160	18	CAB - DASH - RIGHT - POWER DISTRIBUTION PNL			TL23	D56	7	24V AUXILIARY STARTER SOLENOID								
P99	F195	22	CHEMICAL ALARM CONNECTOR			DS66							A234	26	LONG WHEEL BASE LH REAR MARKER LIGHT			CB64	D160	18	CAB - DASH - RIGHT - POWER DISTRIBUTION PNL			TL24	D56	7	24V AUXILIARY STARTER SOLENOID								
PX1	A101	12	ENGINE FAN OFF SWITCH			DS67							H207	23	WRECKER RH SIDE MARKER LIGHT			CB65	D149	17	PARKING LIGHTS			TL25	C56	7	CHASSIS - FRONT								
PX10	D116	13	CAB - DASH - LEFT - INSTRUMENT PANEL			DS67							H234	26	LONG WHEEL BASE RH SIDE MARKER LIGHT			CB66	D152	17	BLACKOUT MARKER POWER			TL25	C71	8	STARTER/STARTER SOLENOID								
PX11	G116	13	CAB - DASH - LEFT - INSTRUMENT PANEL			DS67							H225	25	LONG WHEEL BASE RH SIDE MARKER LIGHT			CB67	D148	17	MARKER LIGHTS			TL26	B56	7	CHASSIS - FRONT								
PX12	C121	14	ROTATING WARNING LIGHT SWITCH															DS67	H234	26	LONG WHEEL BASE RH SIDE MARKER LIGHT			CB68	C161	18	CAB - DASH - RIGHT - POWER DISTRIBUTION PNL			TL26	C71	8	STARTER/STARTER SOLENOID		
PX12A	E121	14	CAB - DASH - LEFT - INSTRUMENT PANEL			DS67							G234	26	ALL MODELS EXCEPT WRECKER, TRACTOR, AND LONG WHEEL BASE BLACKOUT STOP RIGHT REAR			CB70	D155	18	IGNITION/MAIN LIGHT SWITCH			TL27	E94	11	CAB MARKER LIGHTS								
PX13	F101	12	ETHER STARTER SWITCH			DS67							G234	26	ALL MODELS EXCEPT WRECKER, TRACTOR, AND LONG WHEEL BASE RH SIDE MARKER LIGHT			CB71	D158	18	HAZARD/FLASHER WORKLIGHTS			TL27	F242	27	LH FRONT TOP CAB MARKER LIGHT								
PX13A	G101	12	CAB - DASH - LEFT - INSTRUMENT PANEL			DS68	G207	23	WRECKER RH REAR MARKER LIGHT			CB72	D148	17	CAB - DASH - RIGHT - POWER DISTRIBUTION PNL			TL28	G66	8	FUEL SOLENOID														
PX14	F121	14	FULL HAZARD WARNING SWITCH			DS68	G225	25	LONG WHEEL BASE RH REAR MARKER LIGHT			CB73	D159	18	BACK-UP LIGHT POWER			TL29	H66	8	FUEL SOLENOID														
PX14A	H121	14	CAB - DASH - LEFT - INSTRUMENT PANEL			DS68	G226	25	TRACTOR RH REAR MARKER LIGHT			CB74	D159	18	CAB - DASH - RIGHT - POWER DISTRIBUTION PNL			TL30	D206	23	WRECKER REAR LIGHTS														
PX15	C124	14	MAIN LIGHT SWITCH			DS68	G234	26	ALL MODELS EXCEPT WRECKER, TRACTOR, AND LONG WHEEL BASE REAR LEFT COMPOSITE			CB76	D152	17	BLACKOUT STOP RELAY POWER			TL30	E215	24	REAR LIGHTS TRACTOR														
PX17	A121	14	IGNITION SWITCH			DS68	G234	26	ALL MODELS EXCEPT WRECKER, TRACTOR, AND LONG WHEEL BASE RH REAR MARKER LIGHT			CB77	C161	18	ENGINE INSTR POWER			TL30	D224	25	LONG WHEEL BASE														
PX17A	C112	14	CAB - DASH - LEFT - INSTRUMENT PANEL			DS68	G234	26	ALL MODELS EXCEPT WRECKER, TRACTOR, AND LONG WHEEL BASE RH REAR MARKER LIGHT			CB78	D156	18	HEADLIGHTS			TL30	D233	26	LEFT REAR MARKER														
PX1A	B101	12	CAB - DASH - LEFT - INSTRUMENT PANEL			DS69	D207	23	WRECKER LEFT REAR MARKER			CB79	C159	18	WTEC II VIM POWER / WTEC III REVERSE WARNING RELAY			TL31	E206	23	WRECKER REAR LIGHTS														
PX2	D101	12	LAMP TEST SWITCH			DS69	G216	24	TRACTOR LEFT REAR MARKER			CB80	D151	17	TAILLIGHTS			TL31	F215	24	REAR LIGHTS TRACTOR														
PX20	C197	22	TURN SIGNAL FLASHER			DS69	D225	25	LONG WHEEL BASE LEFT REAR MARKER									TL31	E224	25	LONG WHEEL BASE														
PX21	A143	16	WIPER DELAY MODULE			DS69	D234	26	ALL MODELS EXCEPT WRECKER, TRACTOR, AND LONG WHEEL BASE REAR RIGHT COMPOSITE									TL31	E233	26	MIDDLE REAR MARKER														
PX22	A193	22	EMI FILTER			DS70	E207	23	WRECKER MIDDLE REAR MARKER									TL32	E206	23	WRECKER REAR LIGHTS														
PX24	G124	14	INSTRUMENT PANEL LIGHTS DIMMER MODULE			DS70	E207	23	WRECKER MIDDLE REAR MARKER									TL32	G215	24	REAR LIGHTS TRACTOR														
PX25	C128	15	CAB - DASH - CENTER - HEATER/CTIS - ECU			DS70	F216	24	TRACTOR MIDDLE REAR MARKER									TL32	E224	25	LONG WHEEL BASE														
PX26	B188	21	CAB - DASH - LEFT - UNDERDASH			DS70	E225	25	LONG WHEEL BASE MIDDLE REAR MARKER									TL32	E233	26	RIGHT REAR MARKER														
PX2A	E101	12	CAB - DASH - LEFT - INSTRUMENT PANEL			DS70	E234	26	ALL MODELS EXCEPT WRECKER, TRACTOR, AND LONG WHEEL BASE MIDDLE REAR MARKER									TL320	E268	30	PTO EQUIPPED														
PX33	B191	22	CAB - DASH - RIGHT - UNDERDASH			DS71	E207	23	WRECKER RIGHT REAR MARKER									TL320	C277	31	ARCTIC KIT W/PTO EQUIPPED														
PX33	G346	39	WTEC III TRANSMISSION PUSHBUTTON SHIFT SELECTOR			DS71	E216	24	TRACTOR RIGHT REAR MARKER									TL33	E56	7	24V AUXILIARY STARTER SOLENOID														
PX34	E197	22	FRONT AIR PRESSURE METER			DS71	E225	25	LONG WHEEL BASE RIGHT REAR MARKER									TL35	D70	8	ALTERNATOR														
PX4	F106	12	FAN SOLENOID			DS71	E234	26	ALL MODELS EXCEPT WRECKER, TRACTOR, AND LONG WHEEL BASE RIGHT REAR MARKER									TL36	B62	7	POLARITY PROTECTION														
PX5	B106	12	REAR AIR PRESSURE METER			DS71	E234	26	ALL MODELS EXCEPT WRECKER, TRACTOR, AND LONG WHEEL BASE RIGHT REAR MARKER									TL36	F63	7	200 AMP														
PX50	D197	22	INTER-AXLE DIFFERENTIAL SOLENOID			DS72	B207	23	WRECKER REAR LEFT COMPOSITE									TL37	F63	7	200 AMP														
PX6	B116	13	CAB - DASH - LEFT - INSTRUMENT PANEL			DS72	B216	24	TRACTOR REAR LEFT COMPOSITE									TL37	B63	7	POLARITY PROTECTION														
PX7	A113	13	CAB - DASH - LEFT - INSTRUMENT PANEL			DS72	B225	25	LONG WHEEL BASE REAR LEFT COMPOSITE									TL38	D59	7	SHUNT														
PX8	G111	13	CAB - DASH - LEFT - INSTRUMENT PANEL			DS72	B234	26	ALL MODELS EXCEPT WRECKER, TRACTOR, AND LONG WHEEL BASE REAR LEFT COMPOSITE									TL39	C61	7	CHASSIS - REAR (REF E1)														
PX9	D106	12	FUEL LEVEL METER			DS73	F207	23	WRECKER REAR RIGHT COMPOSITE									TL41	B62	7	POLARITY PROTECTION														
D	LIGHTS	NUMBER	ZONE	SH	DESCRIPTION			DS73	F225	25	LONG WHEEL BASE REAR RIGHT COMPOSITE									TL42	B62	7	POLARITY PROTECTION												
		DS1	D105	12	CAB - DASH - LEFT - INSTRUMENT PANEL			DS73	F234	26	ALL MODELS EXCEPT WRECKER, TRACTOR, AND LONG WHEEL BASE REAR RIGHT COMPOSITE									TL44	B62	7	POLARITY PROTECTION												
		DS2	G115	12	CAB - DASH - LEFT - INSTRUMENT PANEL			DS74	D46	6	LEFT HEADLIGHT									TL44	E63	7	200 AMP												
		DS3	F105	12	CAB - DASH - LEFT - INSTRUMENT PANEL			DS74	D46	6	LEFT HEADLIGHT									TL45	D59	7	SHUNT												
		DS4	B105	12	CAB - DASH - LEFT - INSTRUMENT PANEL			DS74	D46	6	LEFT HEADLIGHT									TL46	D58	7	SHUNT												
		DS5	B115	13	CAB - DASH - LEFT - INSTRUMENT PANEL			DS74	D46	6	LEFT HEADLIGHT									TL46	D71	8	STARTER/STARTER SOLENOID												
		DS6	G110	13	CAB - DASH - LEFT - INSTRUMENT PANEL			DS74	D46	6	LEFT HEADLIGHT									TL47	F63	7	200 AMP												
		DS7	D115	13	CAB - DASH - LEFT - INSTRUMENT PANEL			DS74	D46	6	LEFT HEADLIGHT									TL47	C63	7	POLARITY PROTECTION												
		DS8	C100	12	CAB - DASH - LEFT - INSTRUMENT PANEL			DS74	D46	6	LEFT HEADLIGHT									TL48	E61	7	CHASSIS - REAR (REF E2)												
		DS9	B110	13	DUMP BODY UP			DS74	D46	6	LEFT HEADLIGHT									TL49A	D61	7	CHASSIS - REAR (REF E1)												
E	LIGHTS	NUMBER	ZONE	SH	DESCRIPTION			DS74	D46	6	LEFT HEADLIGHT									TL49A	F61	7	NATO SLAVE RECEPTACLE												
		DS10	E120	14	CAB - DASH - LEFT - INSTRUMENT PANEL			DS74	D46	6	LEFT HEADLIGHT									TL50	G130	15	CHASSIS GROUND												
		DS11	G100	12	CAB - DASH - LEFT - INSTRUMENT PANEL			DS74	D46	6	LEFT HEADLIGHT									TL50A	F61	7	NATO SLAVE RECEPTACLE												
		DS12	H120	14	CAB - DASH - LEFT - INSTRUMENT PANEL			DS74	D46	6	LEFT HEADLIGHT									TL51	E59	7	SHUNT												
		DS13	C120	14	CAB - DASH - LEFT - INSTRUMENT PANEL			DS74	D46	6	LEFT HEADLIGHT									TL52	E59	7	SHUNT												
		DS14	B110	13	LEFT TURN SIGNAL			DS74	D46	6	LEFT HEADLIGHT																								
		DS15	B110	13	RIGHT TURN SIGNAL			DS74	D46	6	LEFT HEADLIGHT																								

		37	38	39	40	41	42	43	44	45				
A	MISCELLANEOUS (CONTINUED)											A		
	NUMBER	ZONE	SH	DESCRIPTION										
	E89	C115	13	CAB - DASH - LEFT - INSTRUMENT PANEL										
	E90	E354	40	WTEC III CAB TRANSMISSION HARNESS (TID1)										
	E90	E358	40	WTEC III CAB TRANSMISSION HARNESS (TID2)										
	E91	C354	40	WTEC III CAB TRANSMISSION HARNESS (TID1)										
	E91	C358	40	WTEC III CAB TRANSMISSION HARNESS (TID2)										
	FL	E183	22	WTEC II VEHICLE INTERFACE MODULE										
	FL1	G85	11	EMI FILTER										
	FL2	A184	22	EMI FILTER										
	FL3	C118	15	FAN MOTOR										
	G1	D70	8	ALTERNATOR										
	B	MPU1	F61	8	ENGINE SPEED MAGNETIC PICKUP									
		MT3	G69	8	ENGINE OIL PRESSURE SENSOR									
		MT4	E177	21	SENSOR/FRONT AIR PRESSURE TRANSMITTER									
		MT5	G186	21	SENSOR/REAR AIR PRESSURE TRANSMITTER									
		MT6	B66	8	WATER COOLER TEMPERATURE									
		MT7	B61	7	FUEL TANK LEVEL SENSOR									
		NS	E192	22	WTEC II VEHICLE INTERFACE MODULE									
		NS	F192	22	WTEC II VEHICLE INTERFACE MODULE									
		R11	D59	7	SHUNT									
		C	TB	C309	35	CARGO MATERIAL HANDLING CRANE								
	TB		F309	35	CARGO MATERIAL HANDLING CRANE									
	TB		D319	36	WRECKER MATERIAL HANDLING CRANE									
	TB		E247	38	WRECKER CONTROLS									
	TB1		C137	16	CAB - DASH - RIGHT - POWER DISTRIBUTION PANEL									
	TB2		F139	16	CAB - DASH - RIGHT - POWER DISTRIBUTION PANEL									
	X1		C146	17	24 VDC									
	X11		F61	7	NATO SLAVE RECEPTACLE									
	X2		D146	17	24 VDC									
	X3		F146	17	GROUND									
	D	TRANSMISSION											D	
		NUMBER	ZONE	SH	DESCRIPTION									
		A10	B192	22	WTEC II VEHICLE INTERFACE MODULE									
		A11	C347	39	WTEC III TRANSMISSION ECU									
		A12	G347	39	WTEC III TRANSMISSION PUSHBUTTON SHIFT SELECTOR									
		A13	A75	9	PRE-BLOCK SEVEN TRANSMISSIONS									
		A13	A78	9	TID1, TID2 AND TID3 TRANSMISSIONS									
		A13	A82	10	PRE-BLOCK SEVEN WITH PIGTAIL TRANSMISSIONS									
		B10	E76	9	PRE-BLOCK SEVEN TRANSMISSION OUTPUT SPEED SENSOR									
		B10	E85	10	PRE-BLOCK SEVEN TRANSMISSION WITH PIGTAIL OUTPUT SPEED SENSOR									
	E	B10	E80	9	TID1, TID2, AND TID3 TRANSMISSION OUTPUT SPEED SENSOR									
		MT9	F76	9	PRE-BLOCK SEVEN TRANSMISSION ENGINE SPEED SENSOR									
MT9		F85	10	PRE-BLOCK SEVEN WITH PIGTAIL TRANSMISSION ENGINE SPEED SENSOR										
MT9		F80	9	TID1, TID2, AND TID3 TRANSMISSION ENGINE SPEED SENSOR										
F		MT11	G76	9	PRE-BLOCK SEVEN TRANSMISSION THROTTLE POSITION SENSOR									
		MT11	F85	10	PRE-BLOCK SEVEN WITH PIGTAIL TRANSMISSION THROTTLE POSITION SENSOR									
		MT11	F80	9	TID1, TID2, AND TID3 TRANSMISSION THROTTLE POSITION SENSOR									
G		REV	C192	22	WTEC II VEHICLE INTERFACE MODULE									
		RW	D192	22	WTEC II VEHICLE INTERFACE MODULE									
		S02	F192	22	WTEC II VEHICLE INTERFACE MODULE									
	S03	F192	22	WTEC II VEHICLE INTERFACE MODULE										
	SF01	D192	22	WTEC II VEHICLE INTERFACE MODULE										
	SF01	D192	22	WTEC II VEHICLE INTERFACE MODULE										
	SF02	C192	22	WTEC II VEHICLE INTERFACE MODULE										
	SF02	D192	22	WTEC II VEHICLE INTERFACE MODULE										
	SF3	F192	22	WTEC II VEHICLE INTERFACE MODULE										
	SF04	C192	22	WTEC II VEHICLE INTERFACE MODULE										
SF4	D192	22	WTEC II VEHICLE INTERFACE MODULE											
H	FIGURE FO-1. ELECTRICAL SYSTEM SCHEMATIC FOLDOUT 5 OF 40											H		
	SIZE		B		ILL. NO.		6WD01L5B		FP-9/ (FP-10 BLANK)					

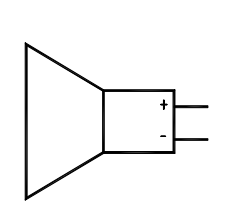
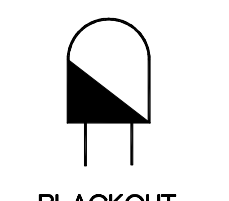
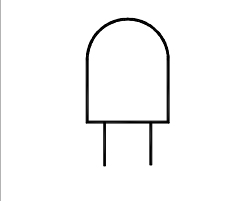
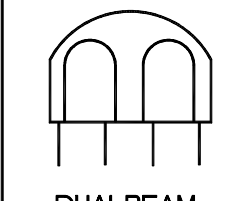
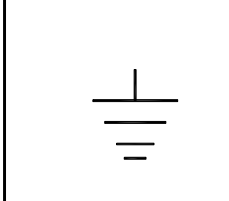
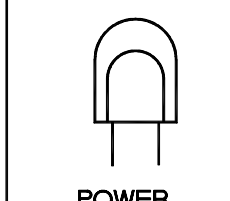
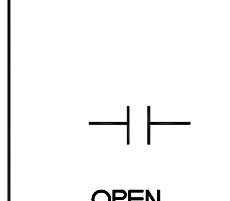
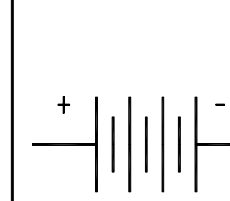
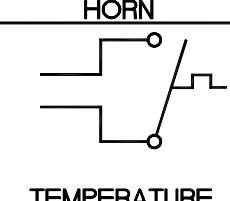
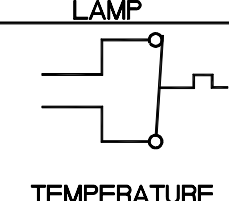
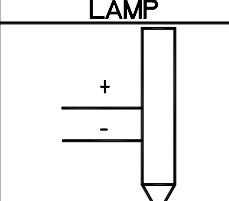
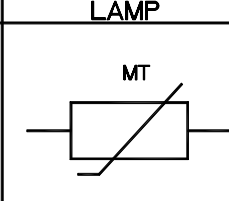
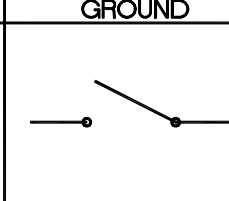
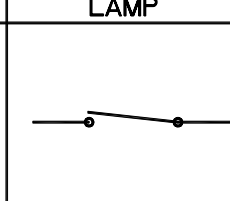
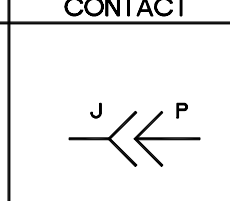
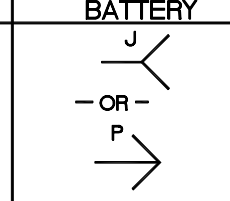
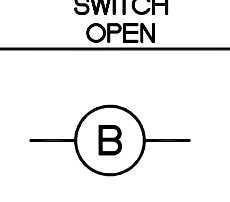
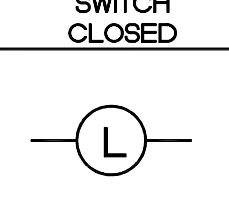
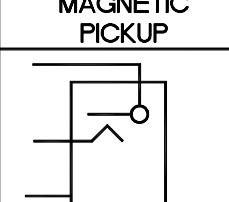
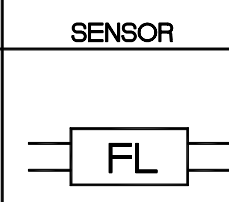
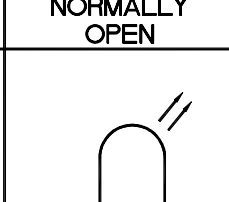
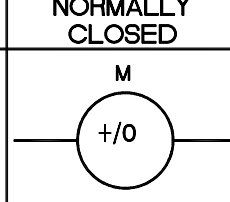
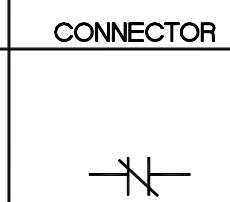
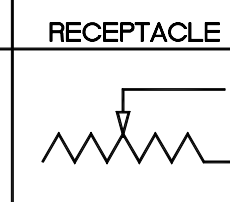
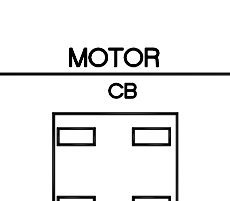
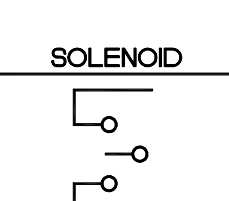
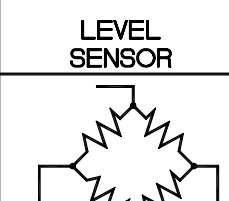
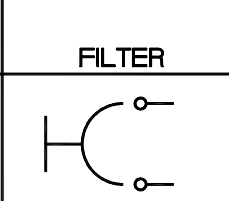
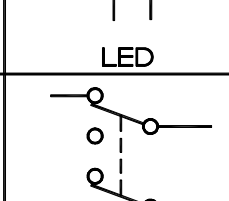
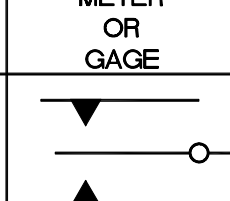
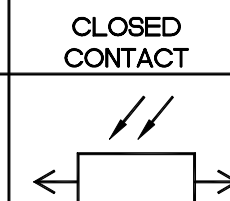
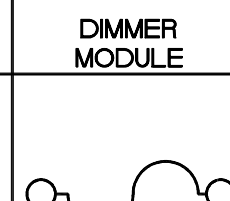
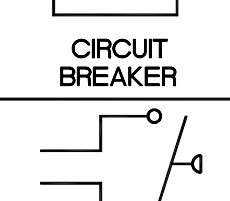
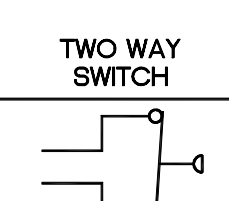
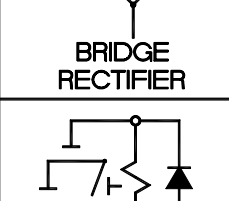
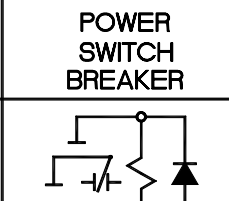
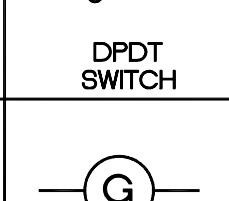
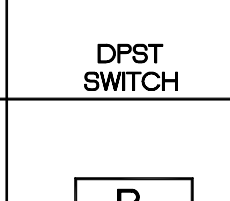
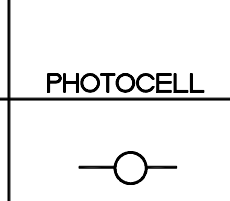
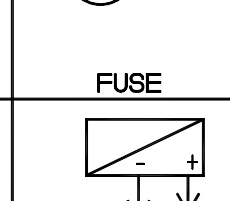
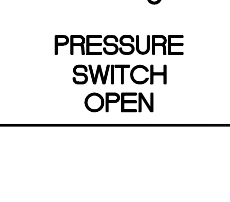
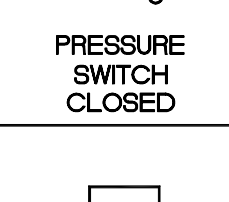
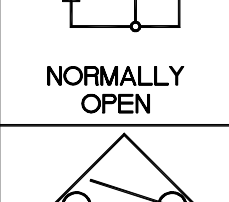
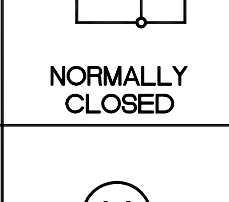
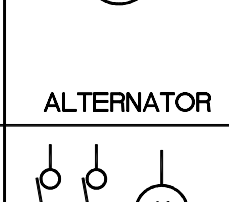
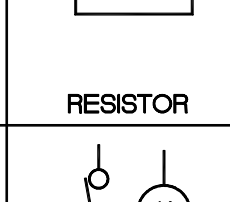
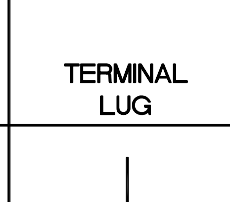
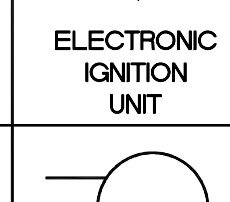
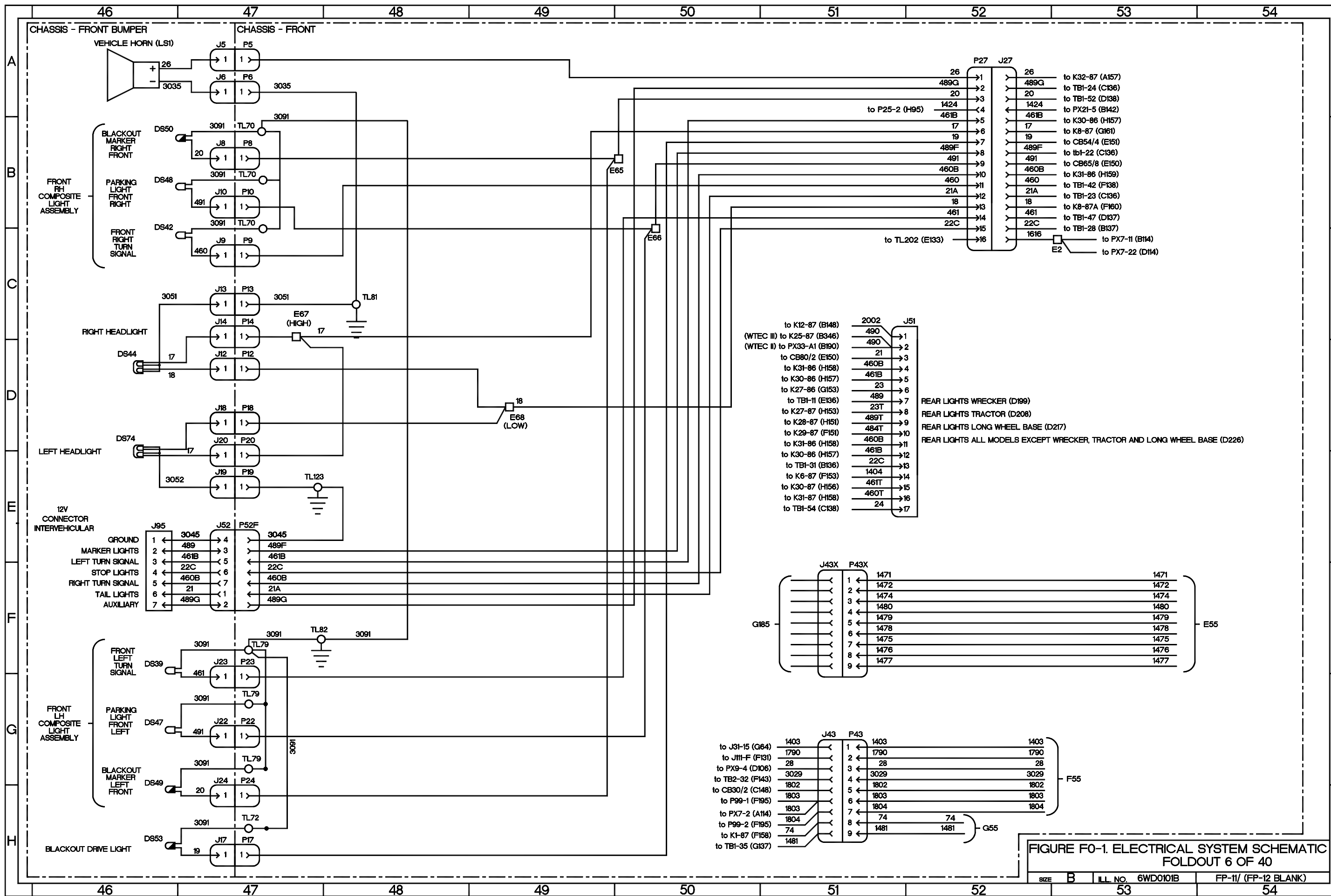

FIGURE FO-1. ELECTRICAL SYSTEM SCHEMATIC FOLDOUT 6 OF 40
 SIZE B ILL. NO. 6WD0101B FP-11/ (FP-12 BLANK)

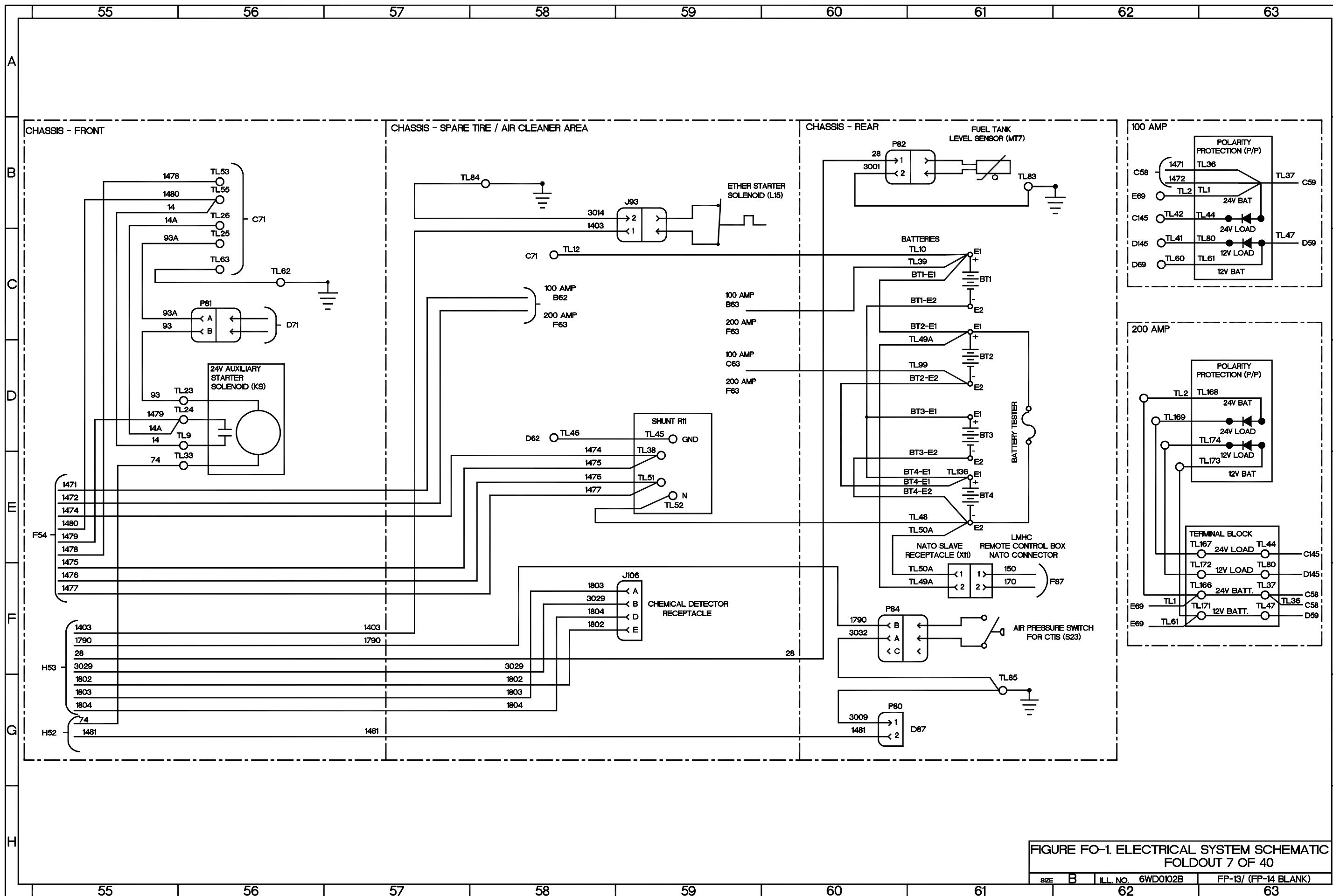

FIGURE FO-1. ELECTRICAL SYSTEM SCHEMATIC FOLDOUT 7 OF 40

SIZE	B	ILL. NO.	6WD0102B	FP-13/ (FP-14 BLANK)
------	---	----------	----------	----------------------

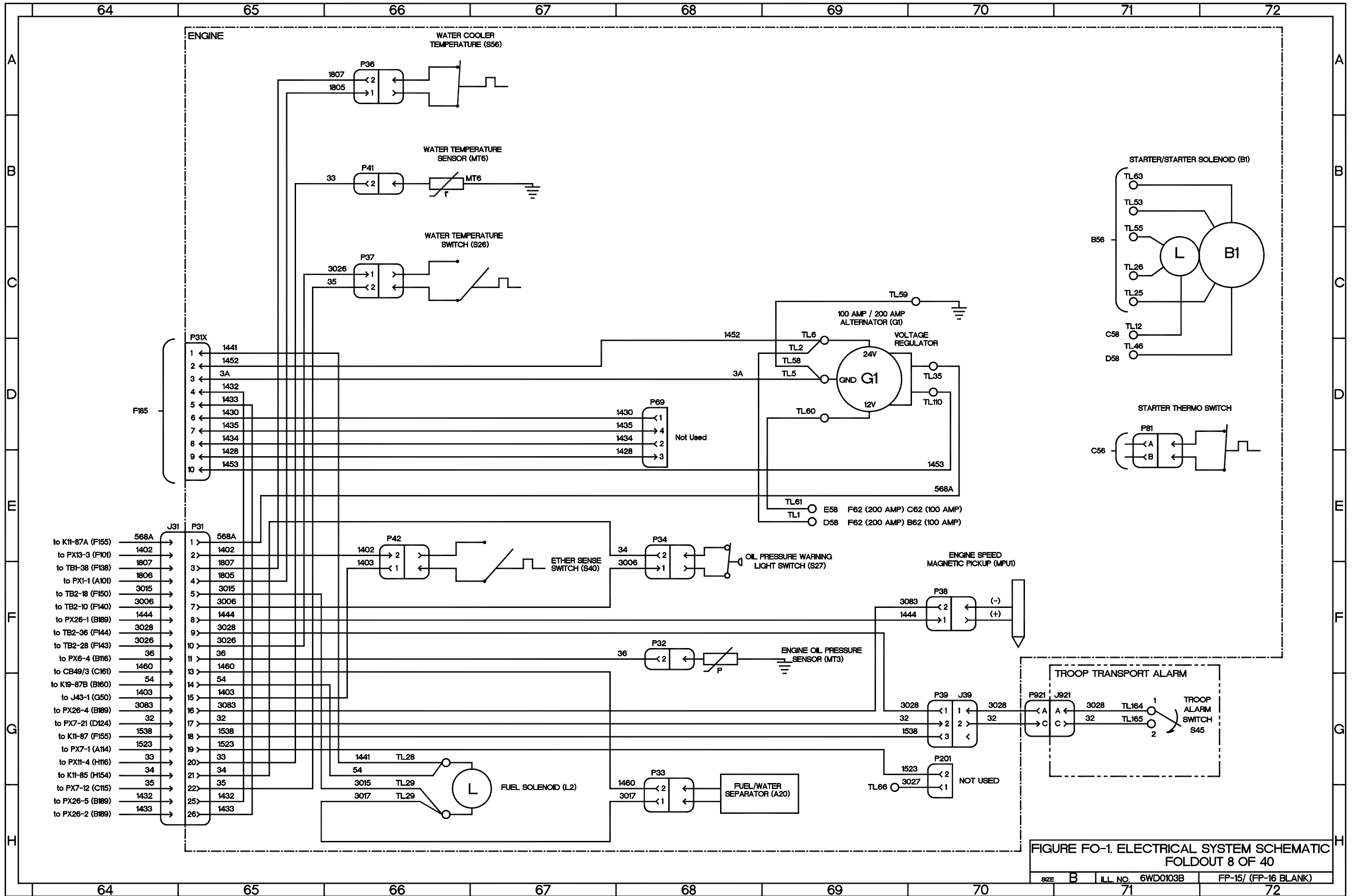
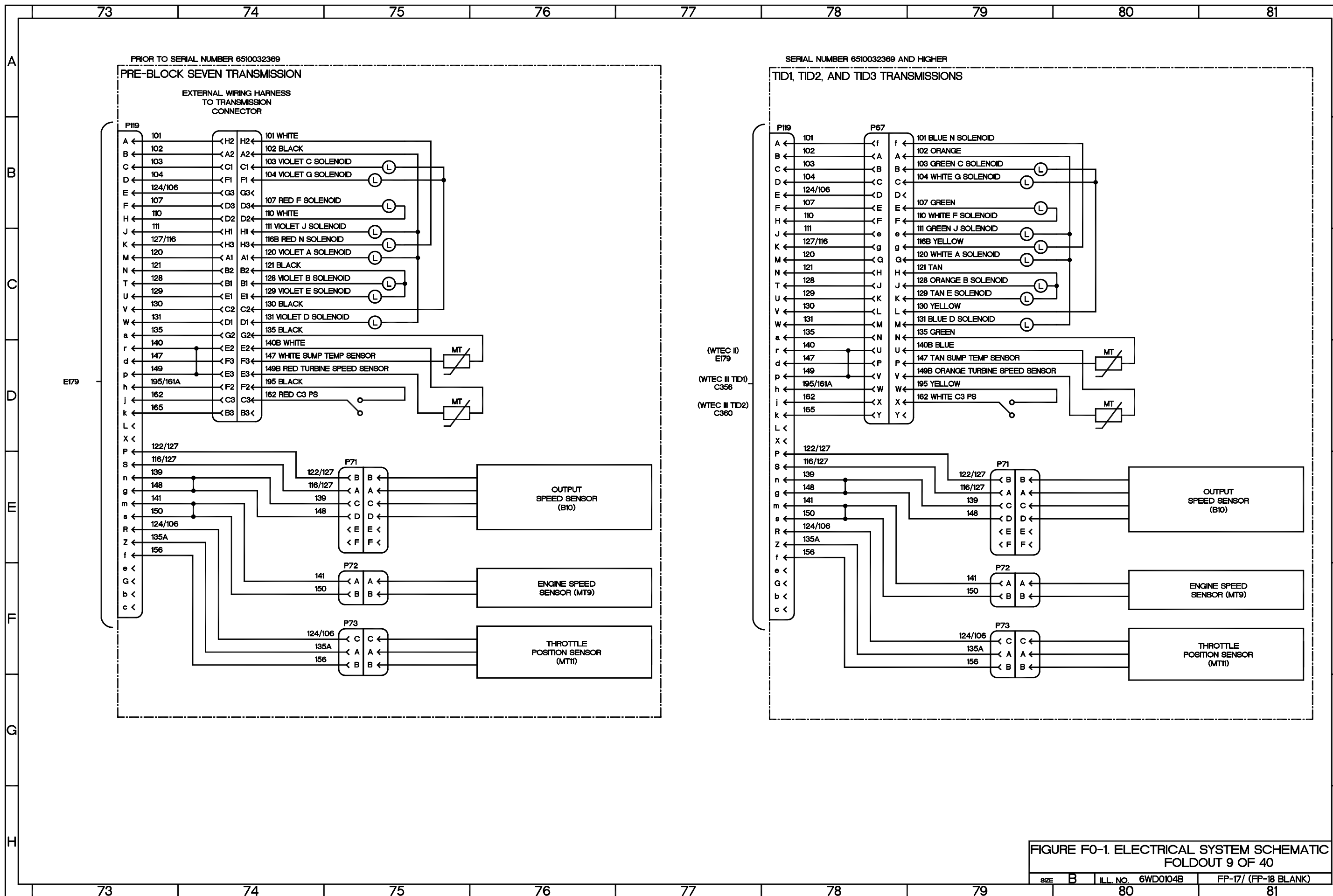

FIGURE FO-1. ELECTRICAL SYSTEM SCHEMATIC FOLDOUT 8 OF 40

SIZE	B	ILL. NO.	6WD0103B	FP-15/ (FP-16 BLANK)
------	---	----------	----------	----------------------



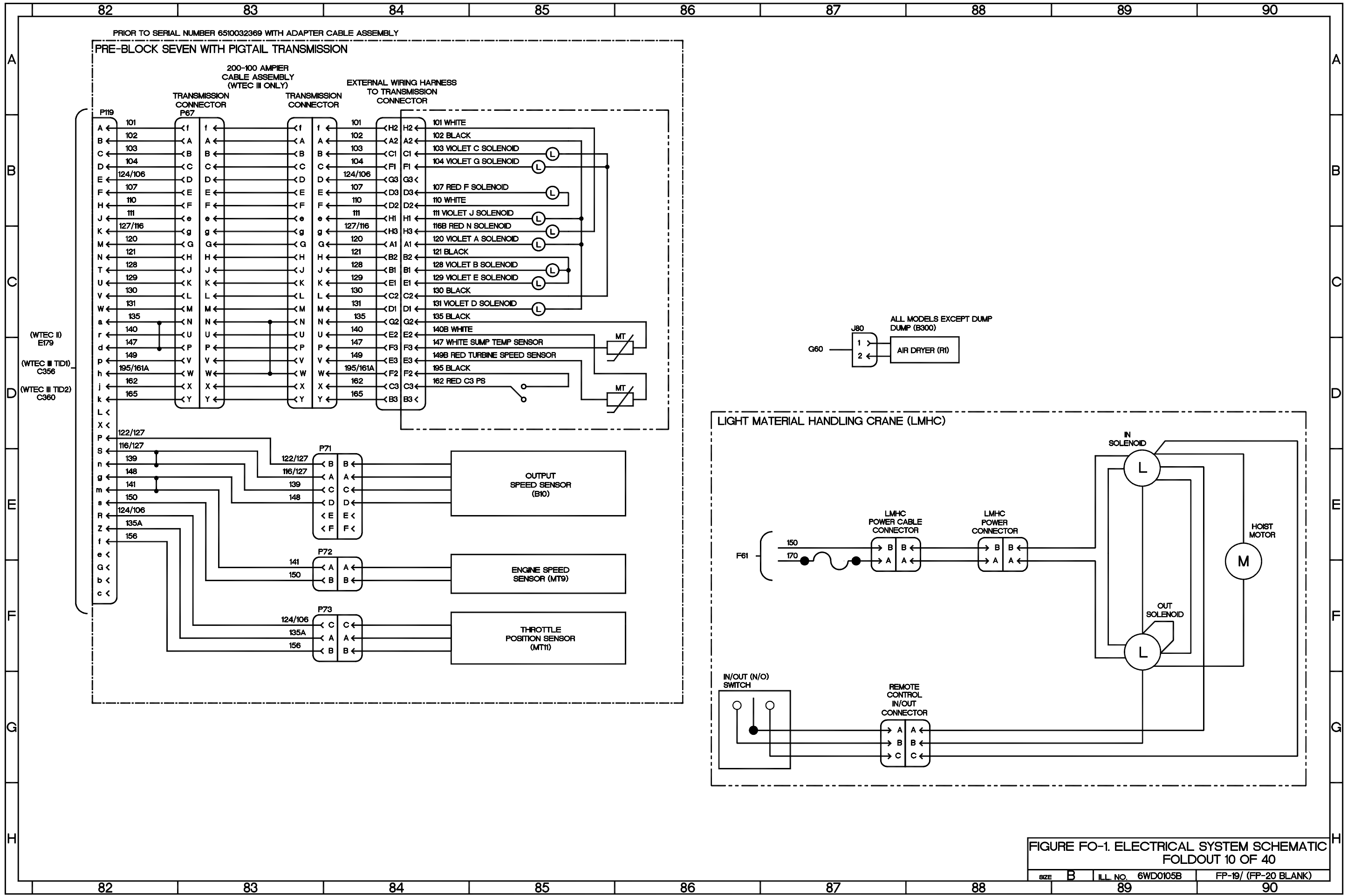
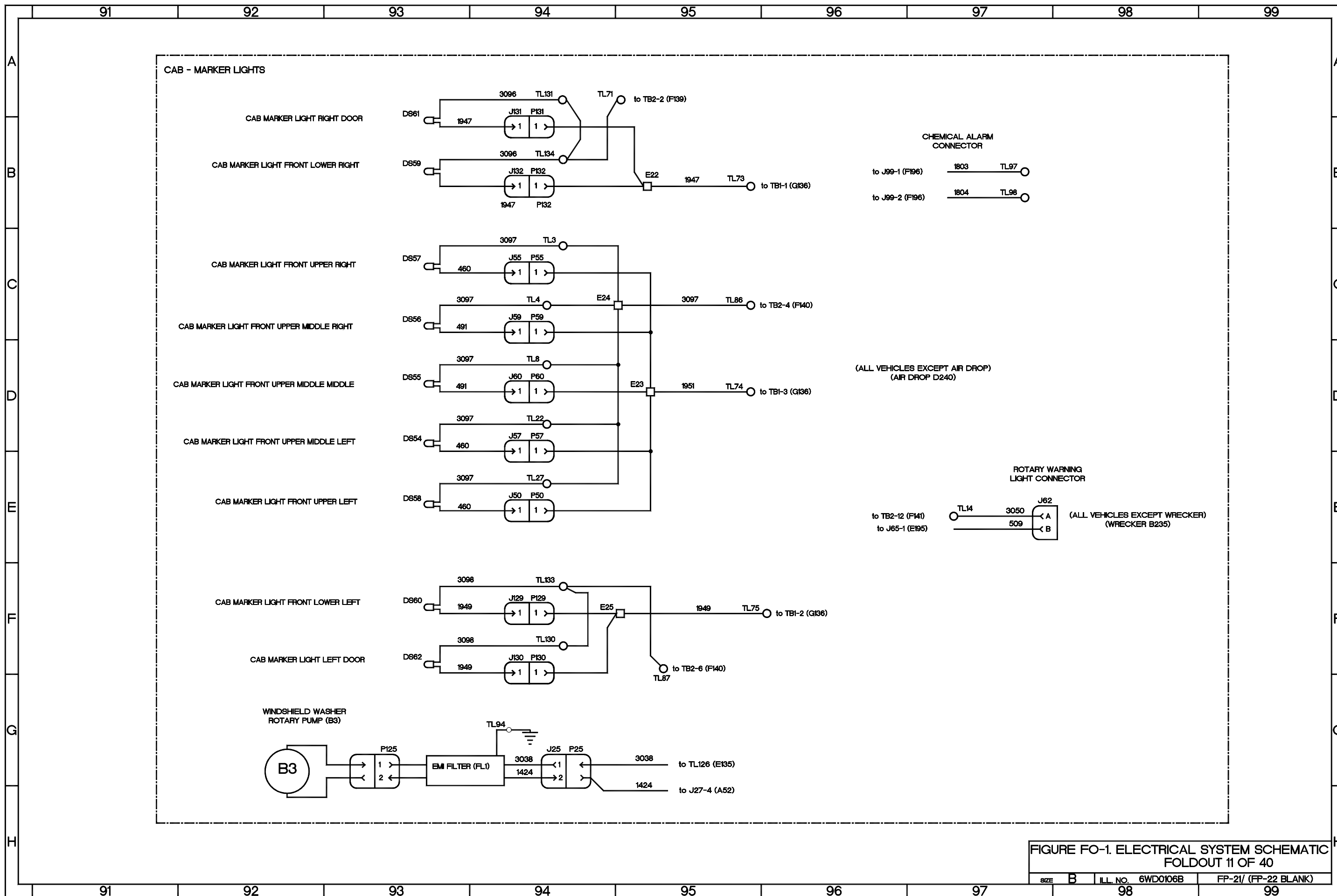

FIGURE FO-1. ELECTRICAL SYSTEM SCHEMATIC FOLDOUT 10 OF 40

SIZE	B	ILL. NO.	6WD0105B	FP-19/ (FP-20 BLANK)
------	---	----------	----------	----------------------



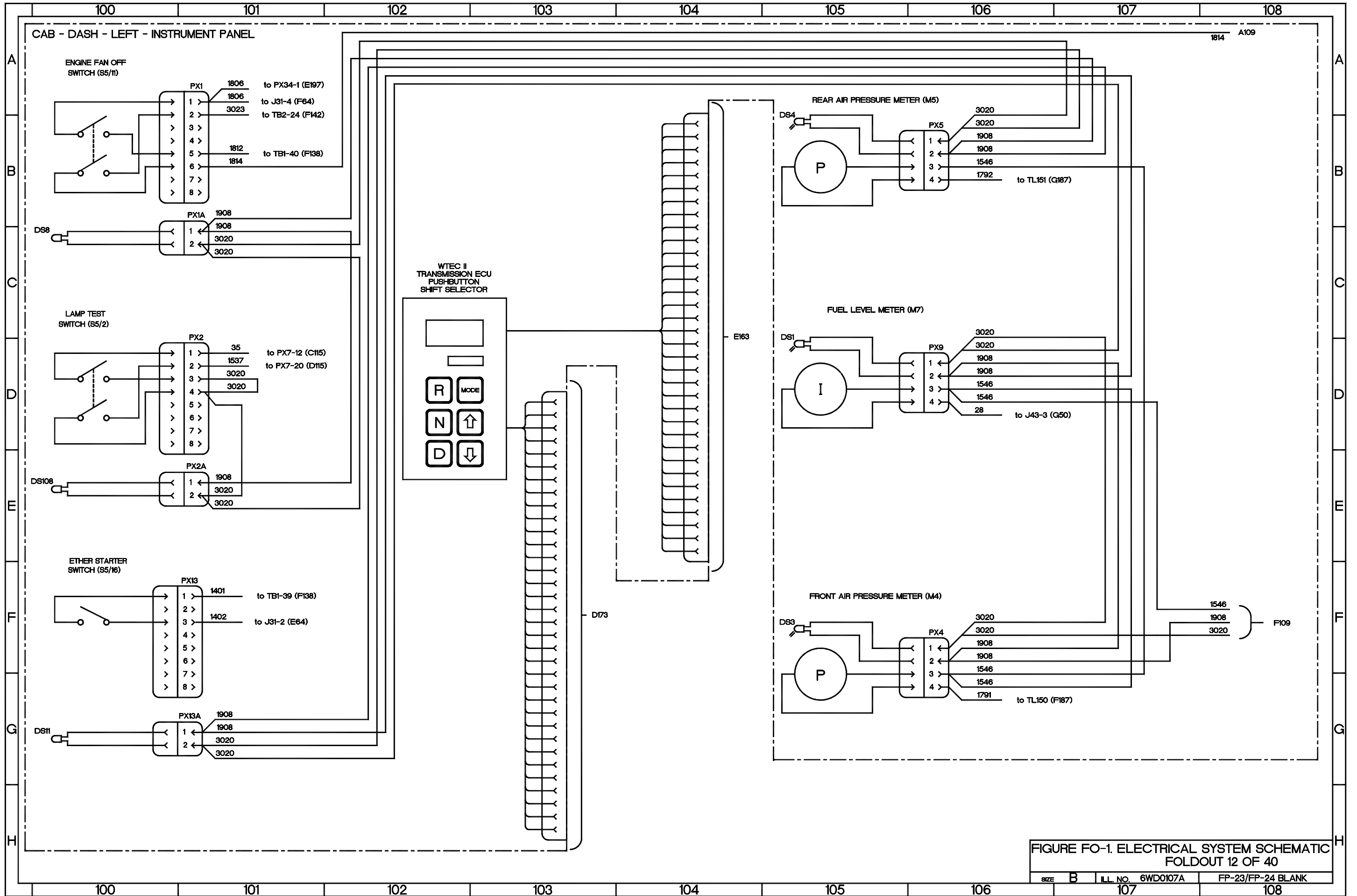

FIGURE FO-1. ELECTRICAL SYSTEM SCHEMATIC FOLDOUT 12 OF 40

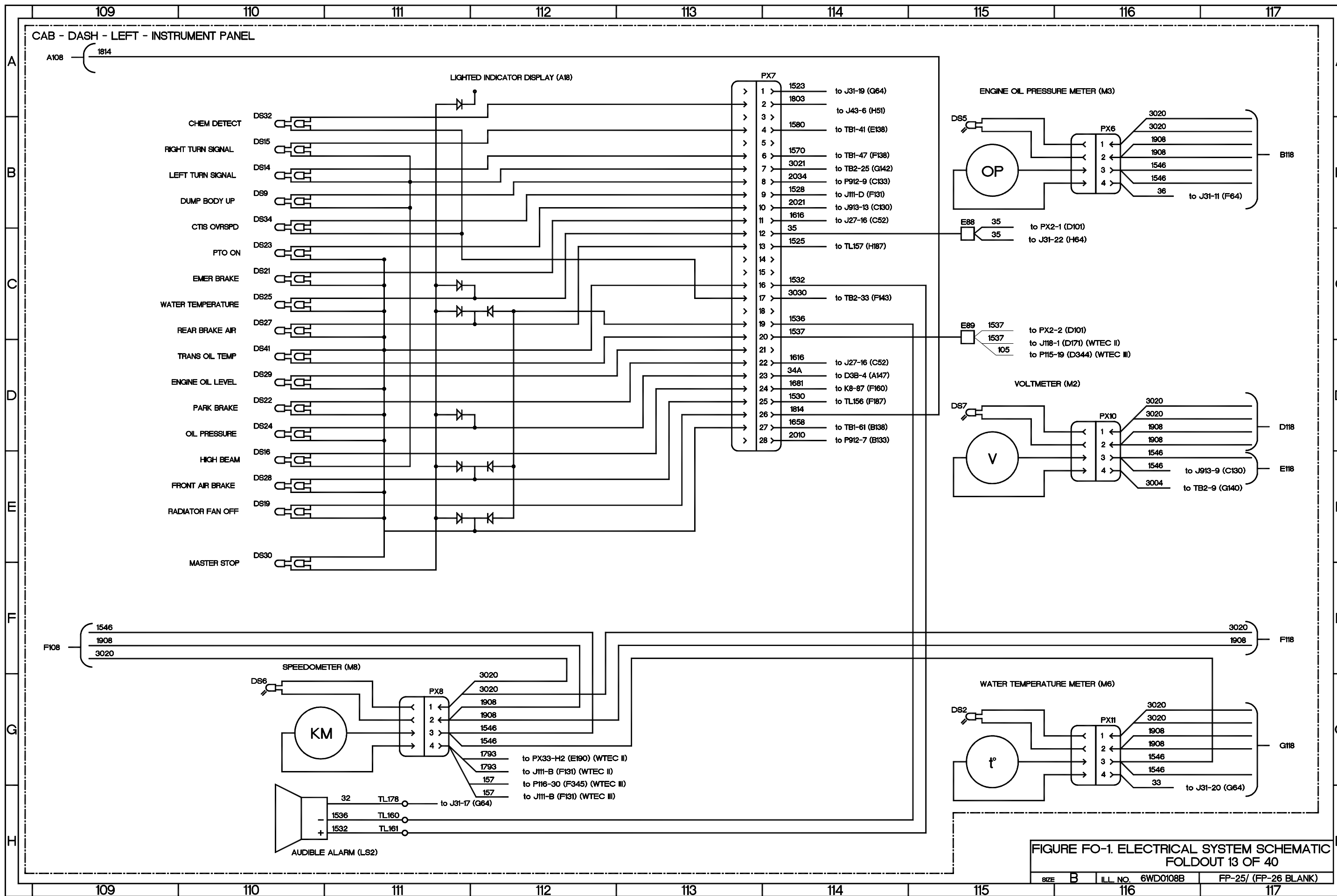

FIGURE FO-1. ELECTRICAL SYSTEM SCHEMATIC FOLDOUT 13 OF 40

SIZE	B	ILL. NO.	6WD0108B	FP-25/ (FP-26 BLANK)
------	---	----------	----------	----------------------

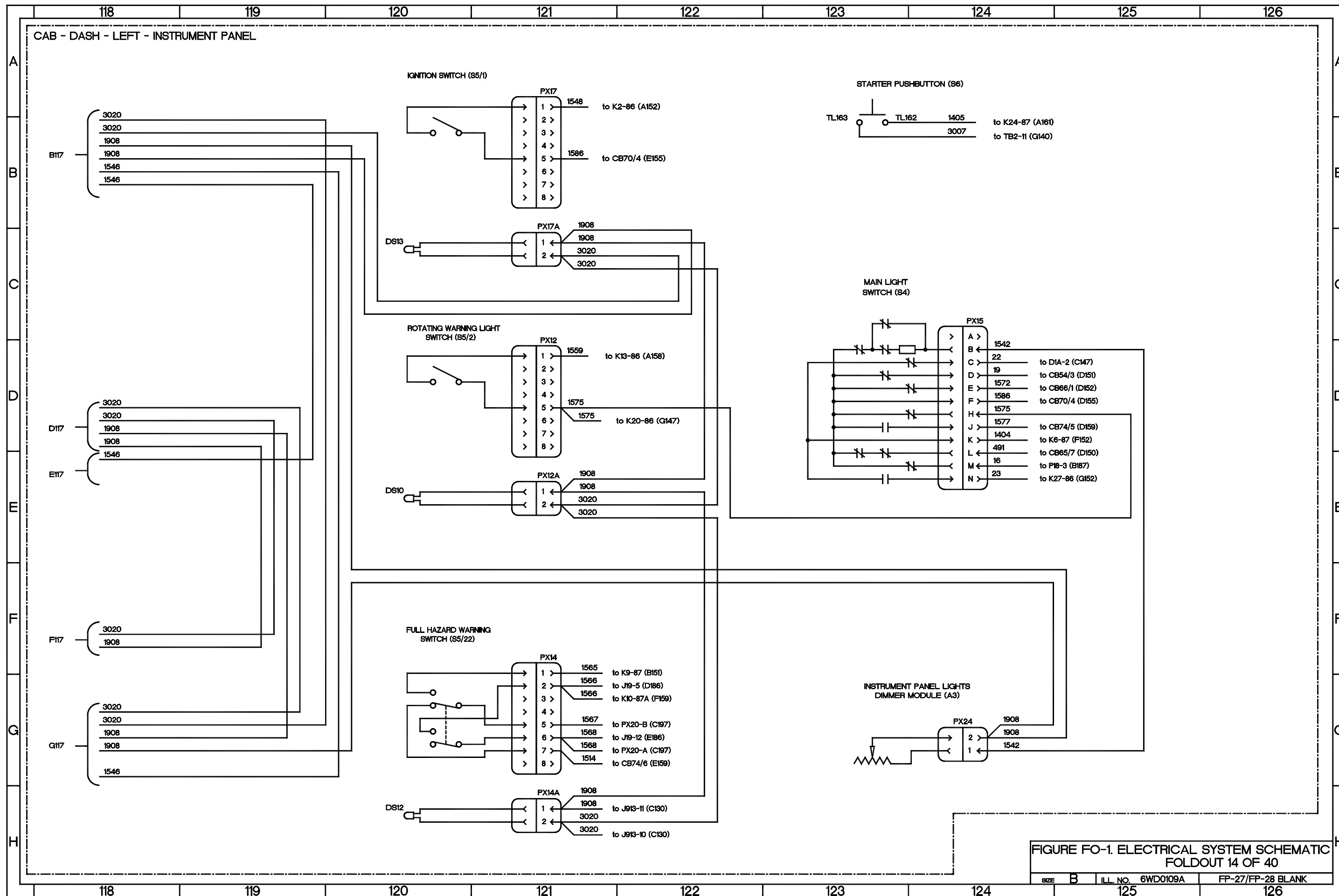

FIGURE FO-1. ELECTRICAL SYSTEM SCHEMATIC FOLDOUT 14 OF 40

SIZE	B	ILL. NO.	6WD0109A	FP-27/FP-28	BLANK
------	---	----------	----------	-------------	-------

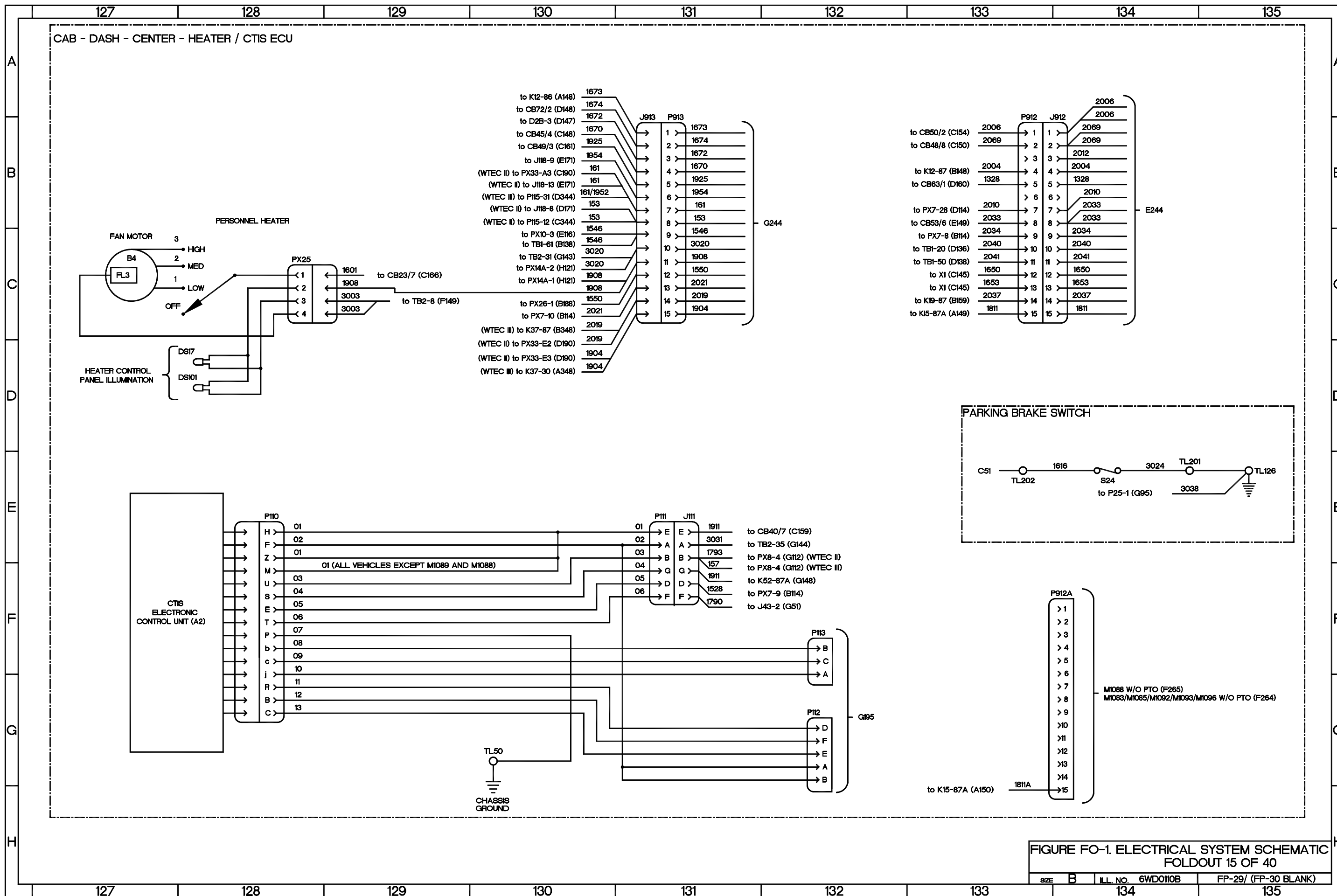
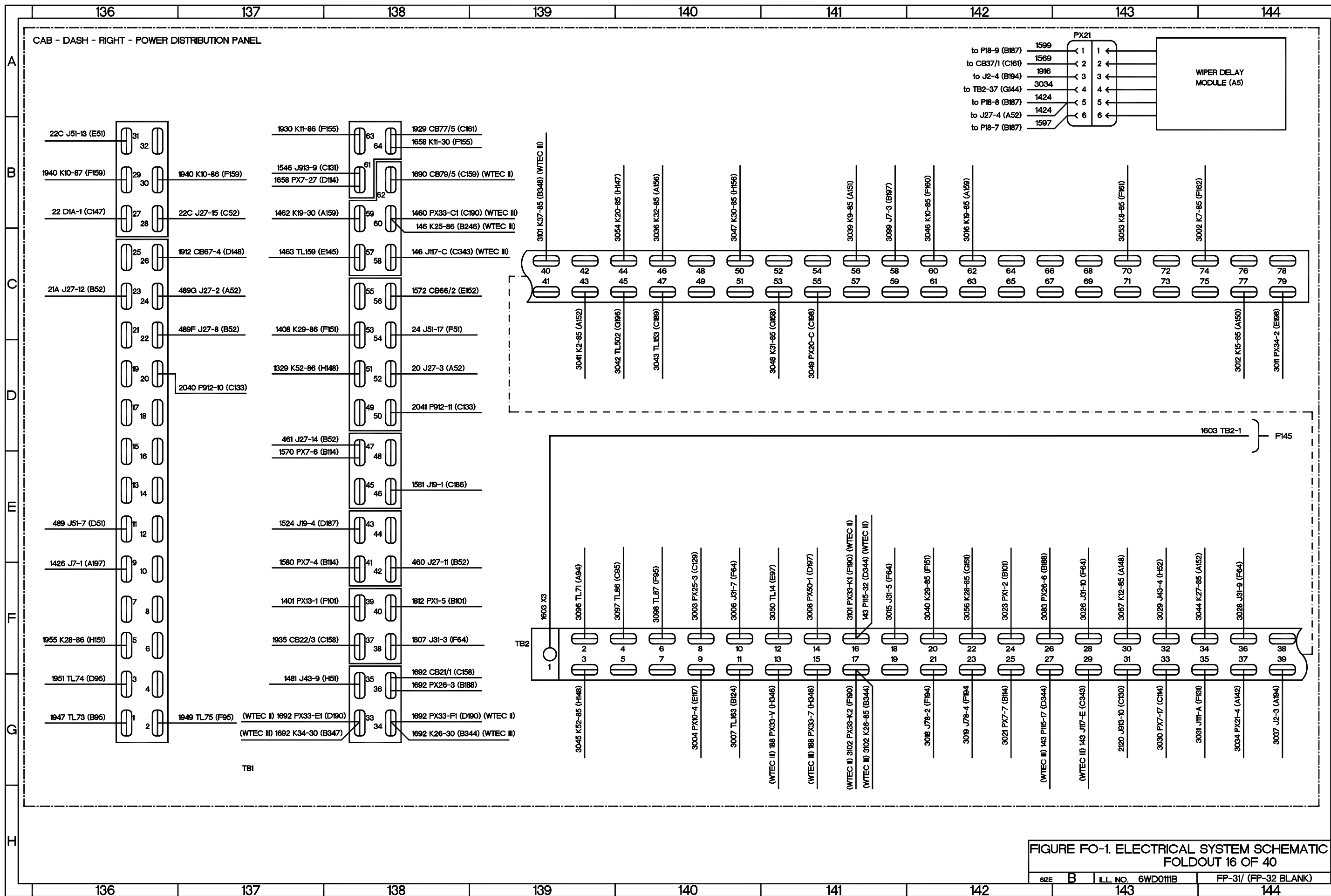
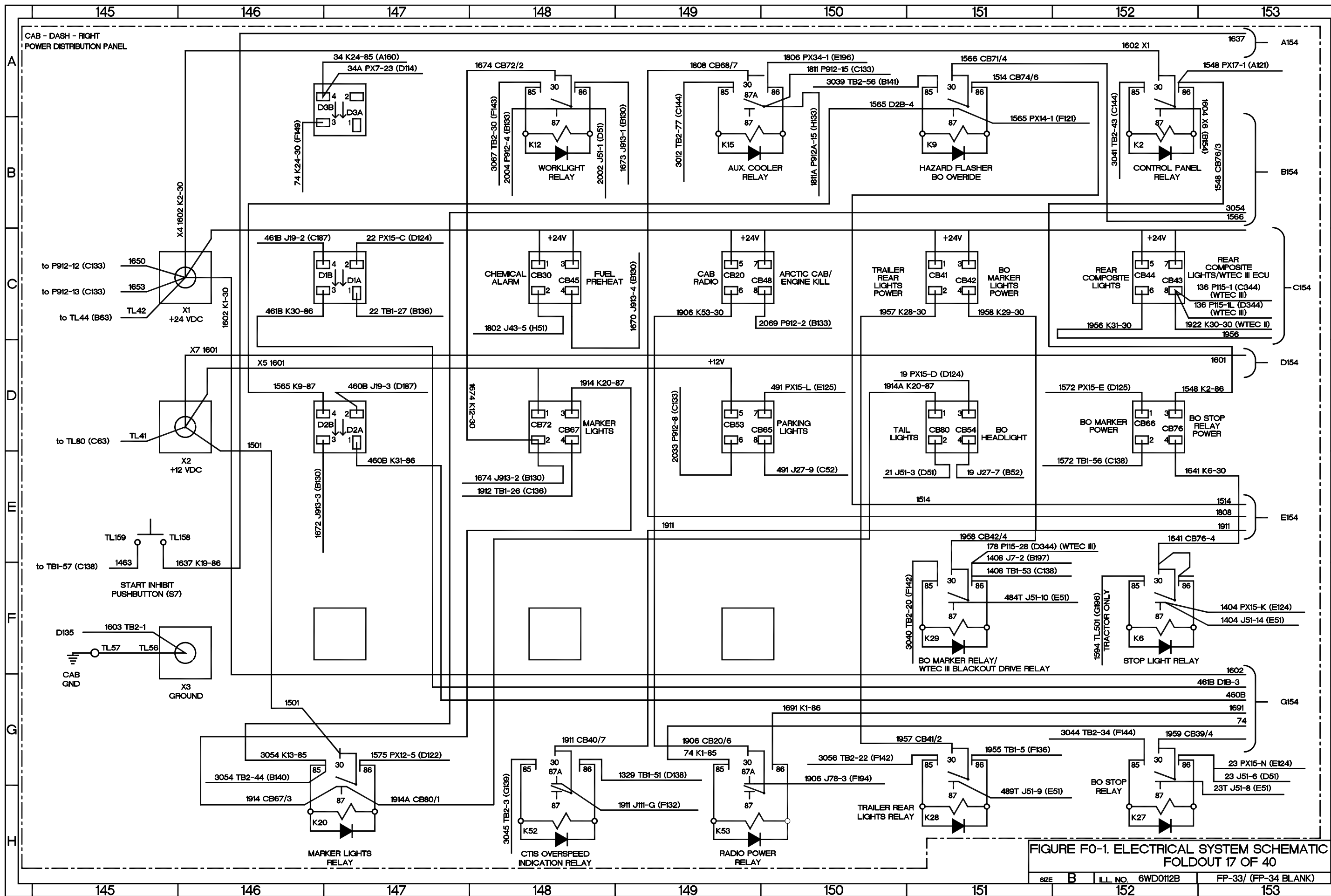

FIGURE FO-1. ELECTRICAL SYSTEM SCHEMATIC FOLDOUT 15 OF 40

SIZE	B	ILL. NO.	6WD010B	FP-29/ (FP-30 BLANK)
------	---	----------	---------	----------------------





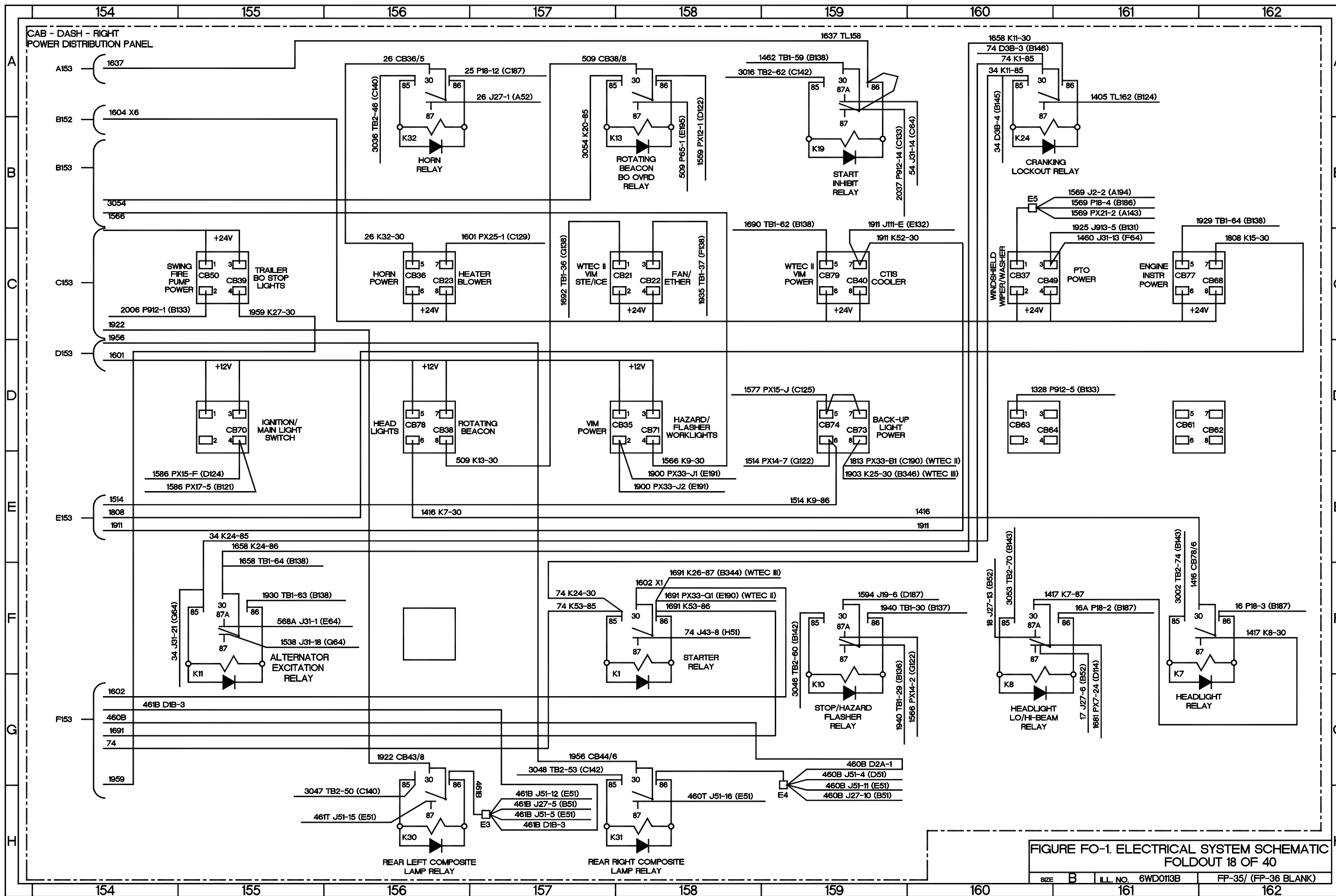

FIGURE FO-1. ELECTRICAL SYSTEM SCHEMATIC FOLDOUT 18 OF 40

SIZE	B	ILL. NO.	6WD0113B	FP-35/ (FP-36 BLANK)
------	---	----------	----------	----------------------

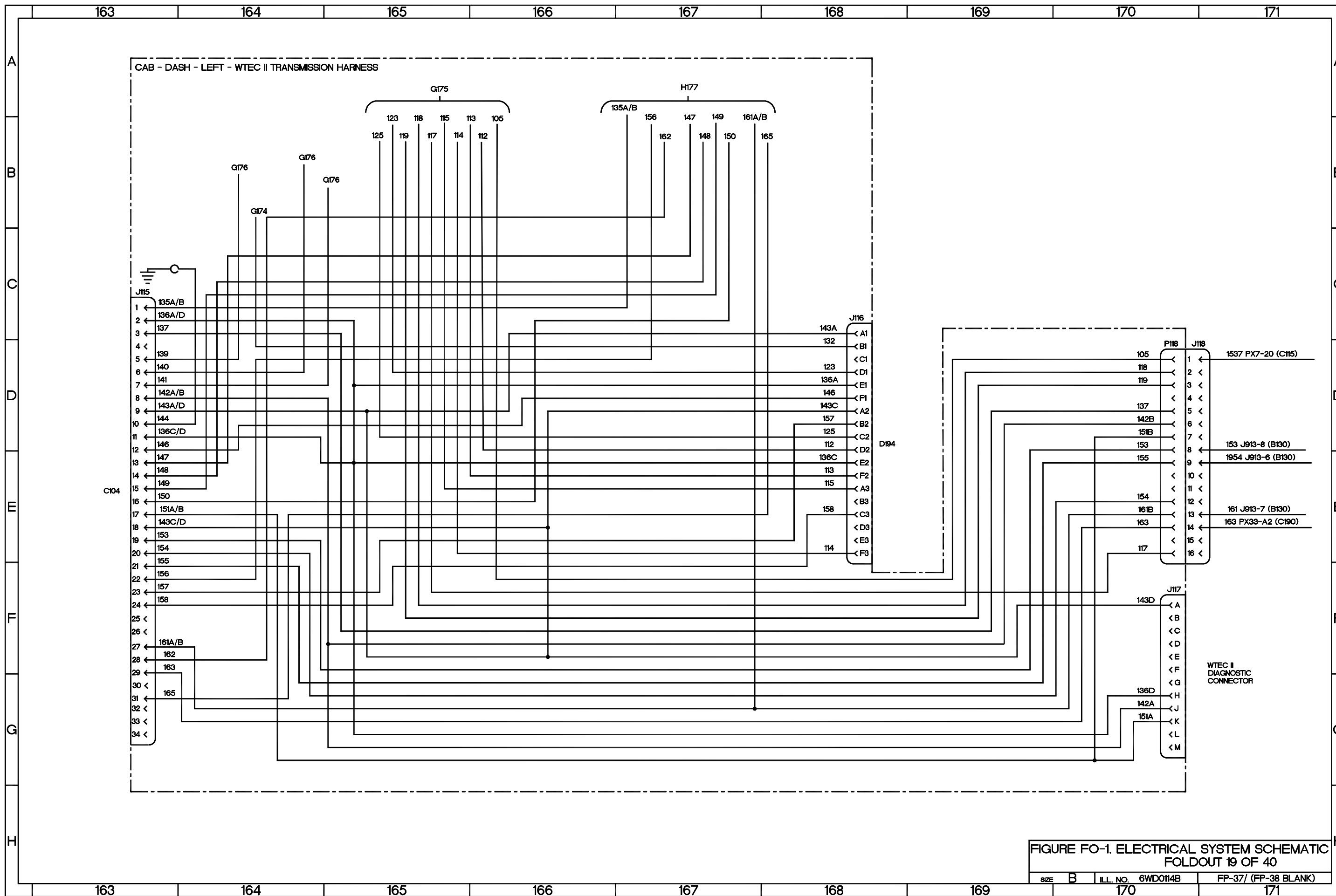

FIGURE FO-1. ELECTRICAL SYSTEM SCHEMATIC FOLDOUT 19 OF 40

SIZE	B	ILL. NO.	6WD0114B	FP-37/ (FP-38 BLANK)
------	---	----------	----------	----------------------

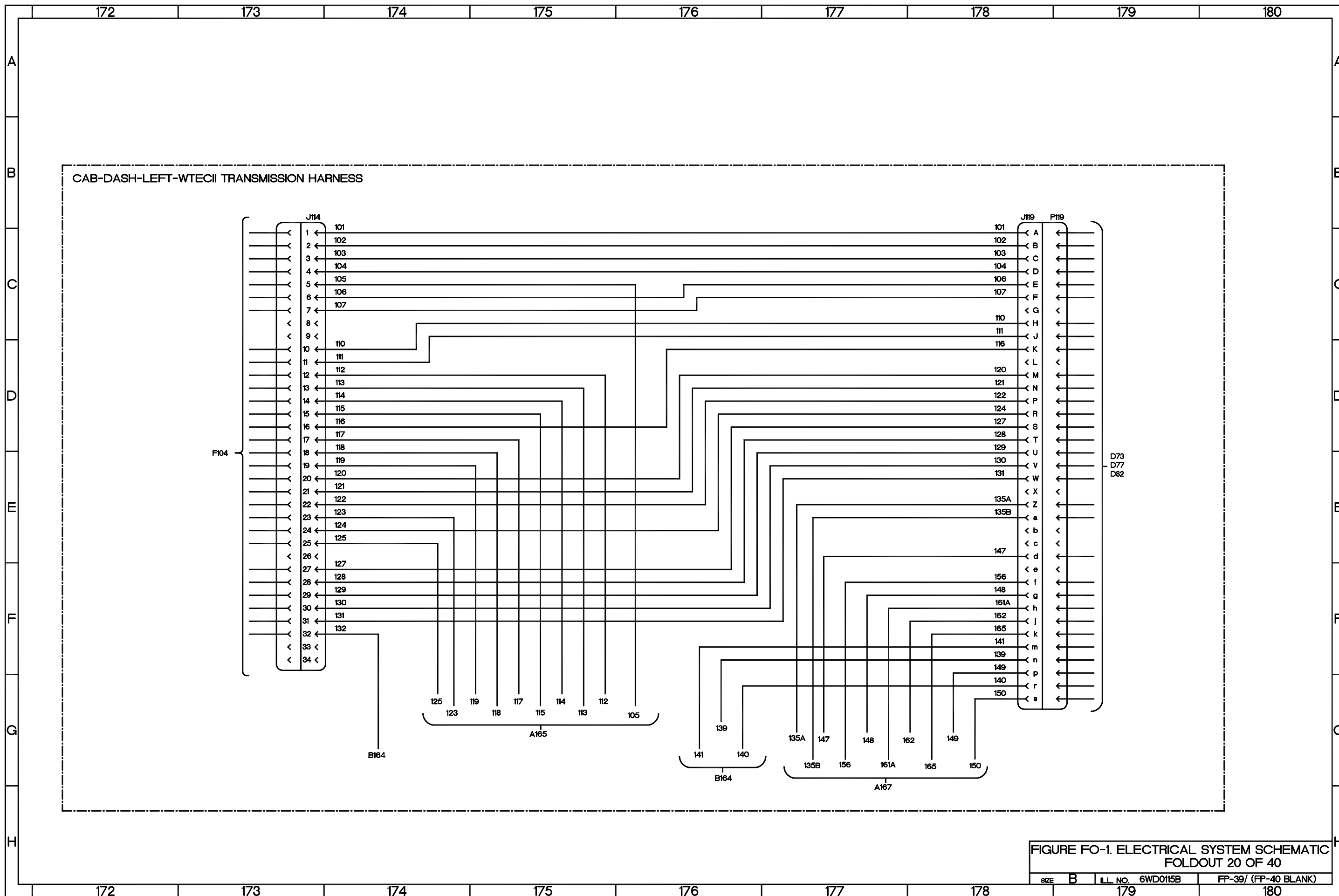

FIGURE FO-1. ELECTRICAL SYSTEM SCHEMATIC
 FOLDOUT 20 OF 40
 SIZE B ILL. NO. 6WD0115B FP-39/ (FP-40 BLANK)

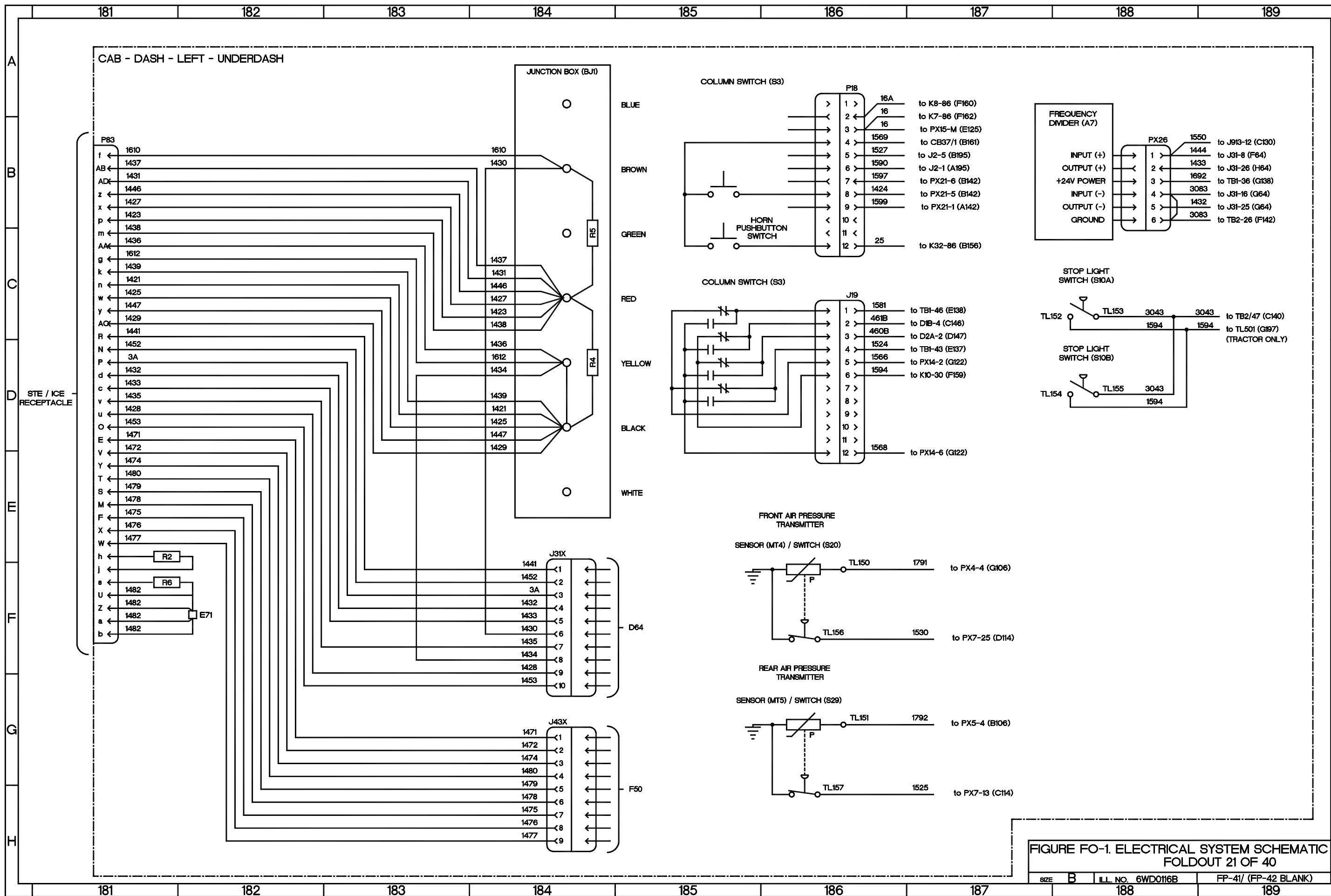

FIGURE FO-1. ELECTRICAL SYSTEM SCHEMATIC FOLDOUT 21 OF 40

SIZE B ILL. NO. 6WD0116B FP-41/ (FP-42 BLANK)

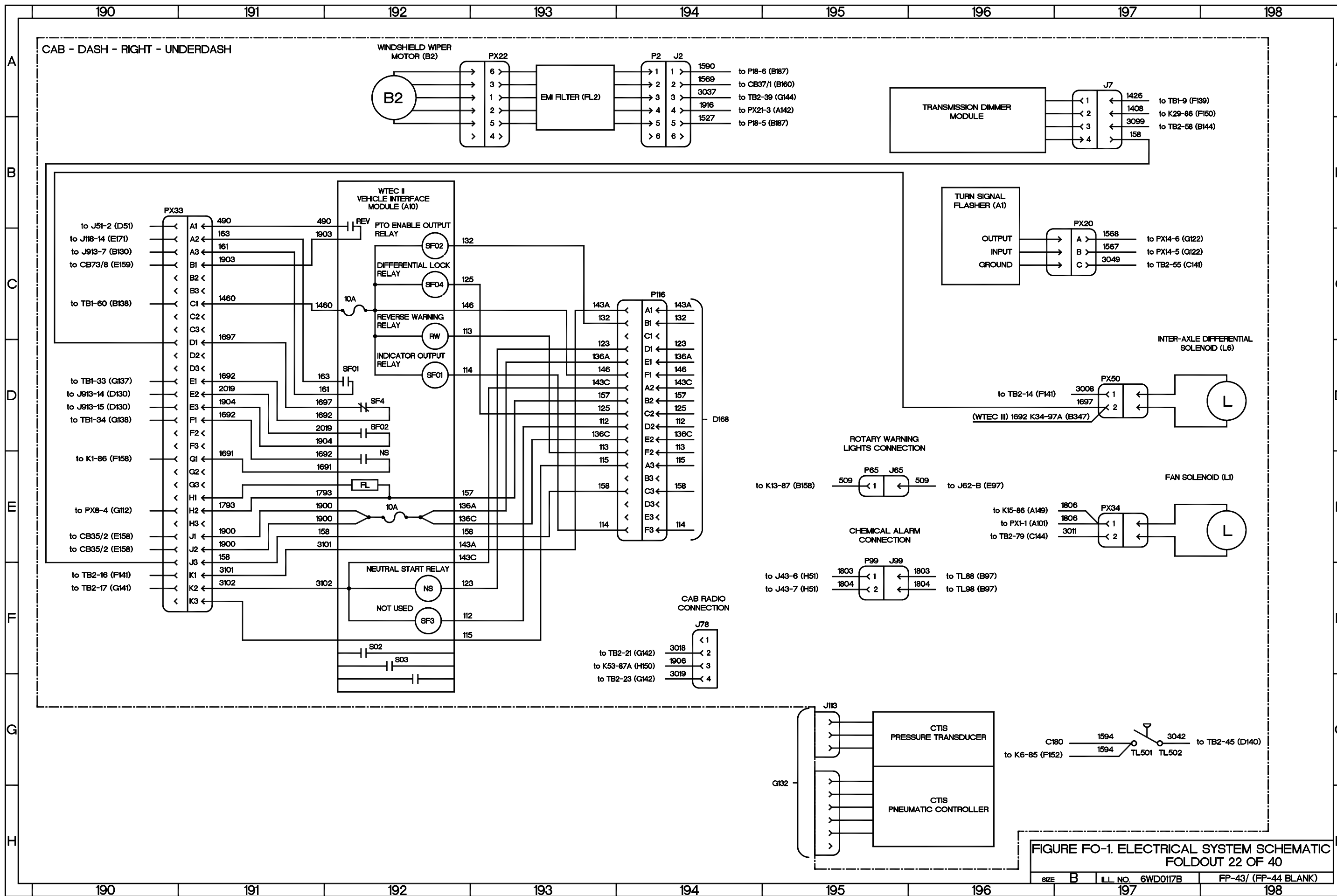

FIGURE FO-1. ELECTRICAL SYSTEM SCHEMATIC FOLDOUT 22 OF 40

SIZE B ILL. NO. 6WD0117B FP-43/ (FP-44 BLANK)

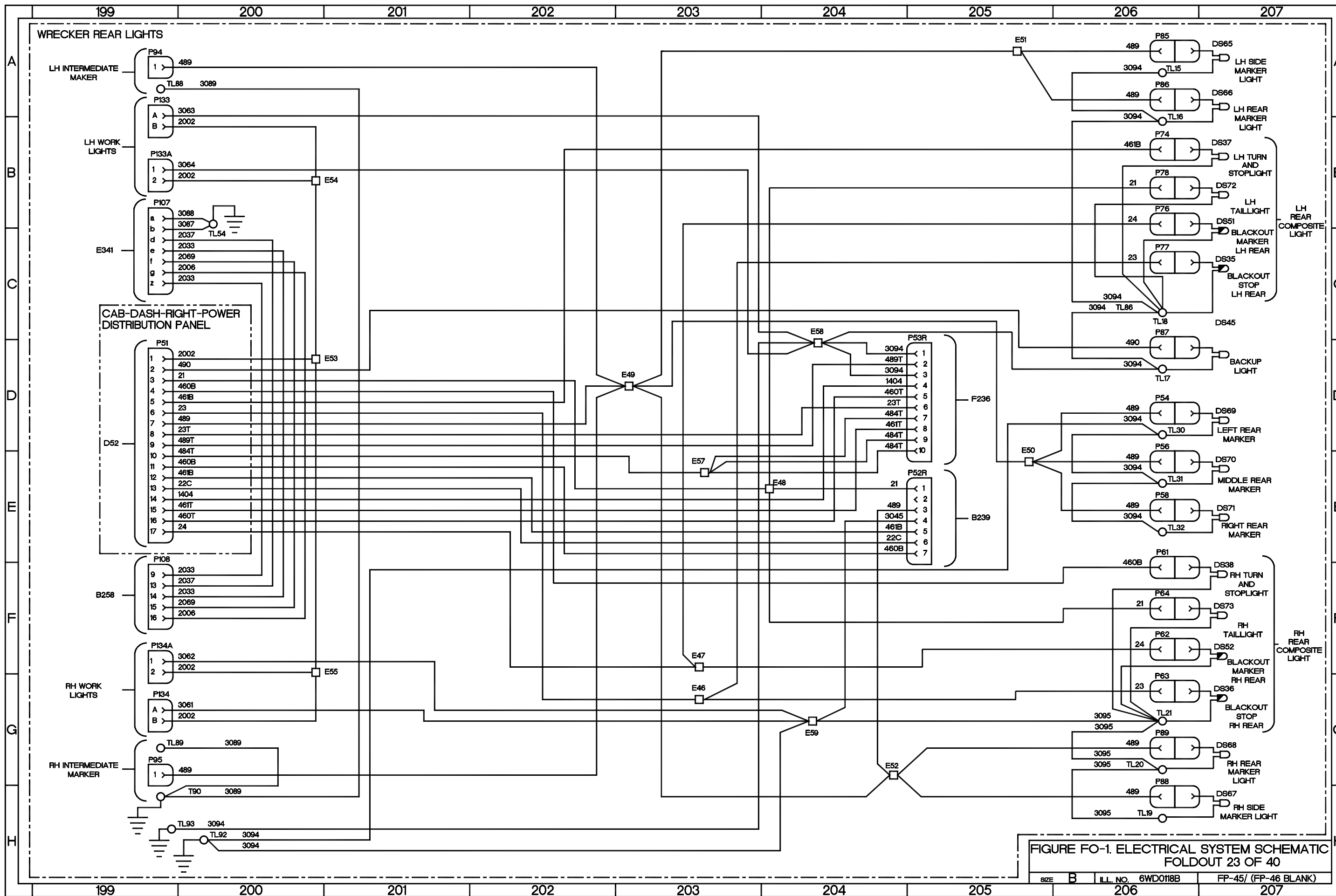

FIGURE FO-1. ELECTRICAL SYSTEM SCHEMATIC FOLDOUT 23 OF 40
 SIZE B ILL. NO. 6WD0118B FP-45/ (FP-46 BLANK)

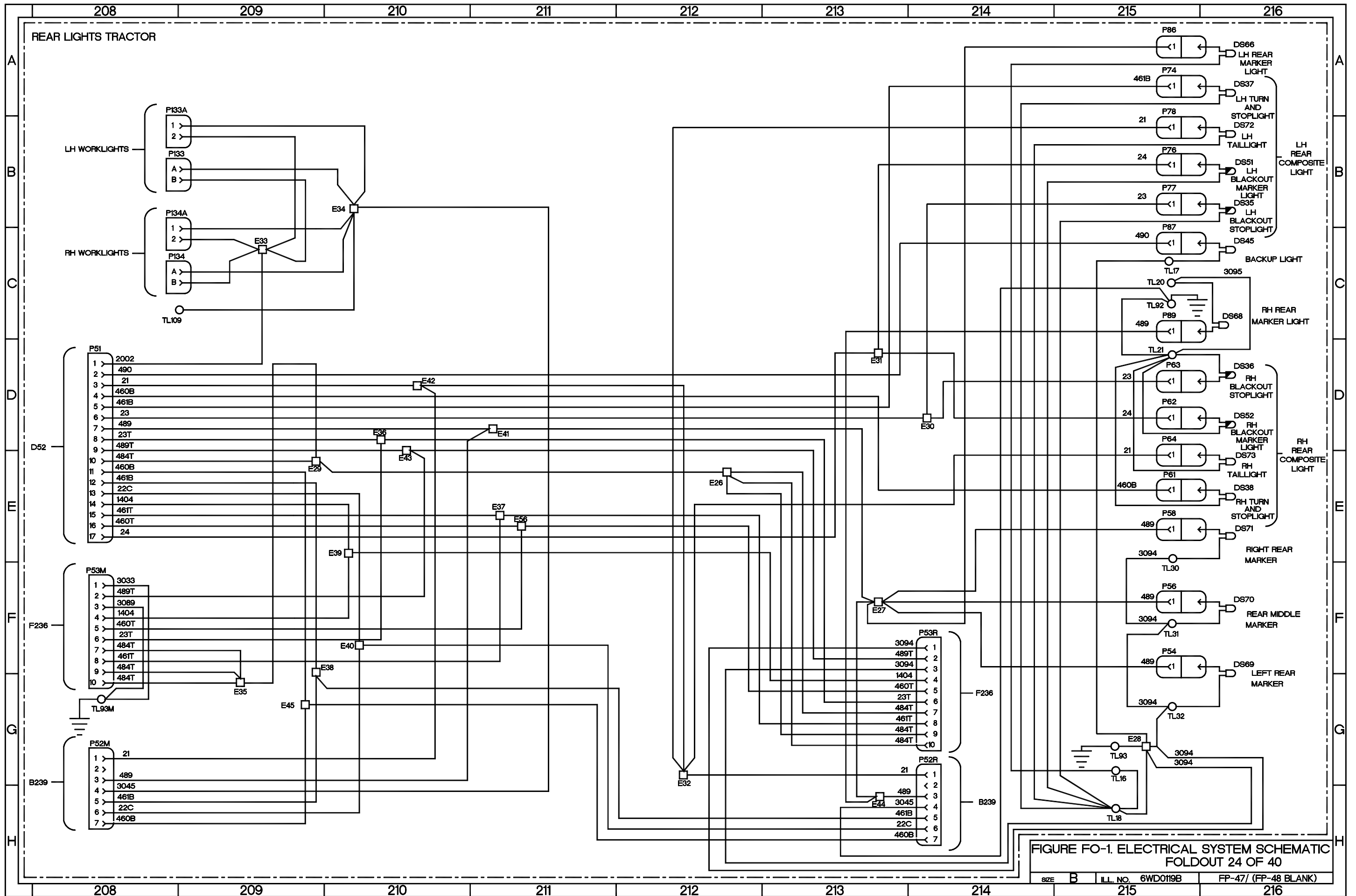

FIGURE FO-1. ELECTRICAL SYSTEM SCHEMATIC FOLDOUT 24 OF 40

SIZE B ILL. NO. 6WD0119B FP-47/ (FP-48 BLANK)

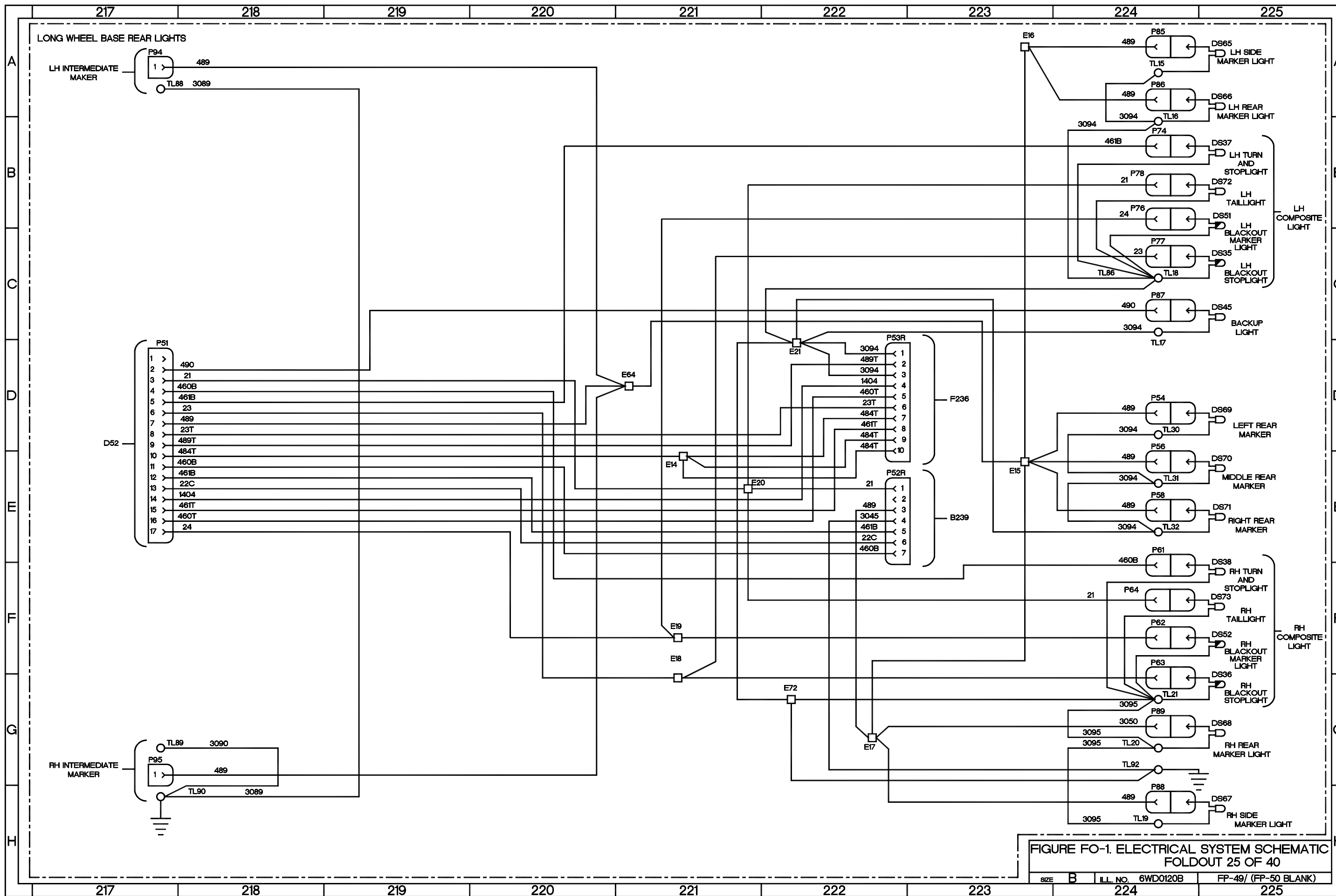

FIGURE FO-1. ELECTRICAL SYSTEM SCHEMATIC FOLDOUT 25 OF 40

SIZE	B	ILL. NO.	6WD0120B	FP-49/ (FP-50 BLANK)
------	---	----------	----------	----------------------

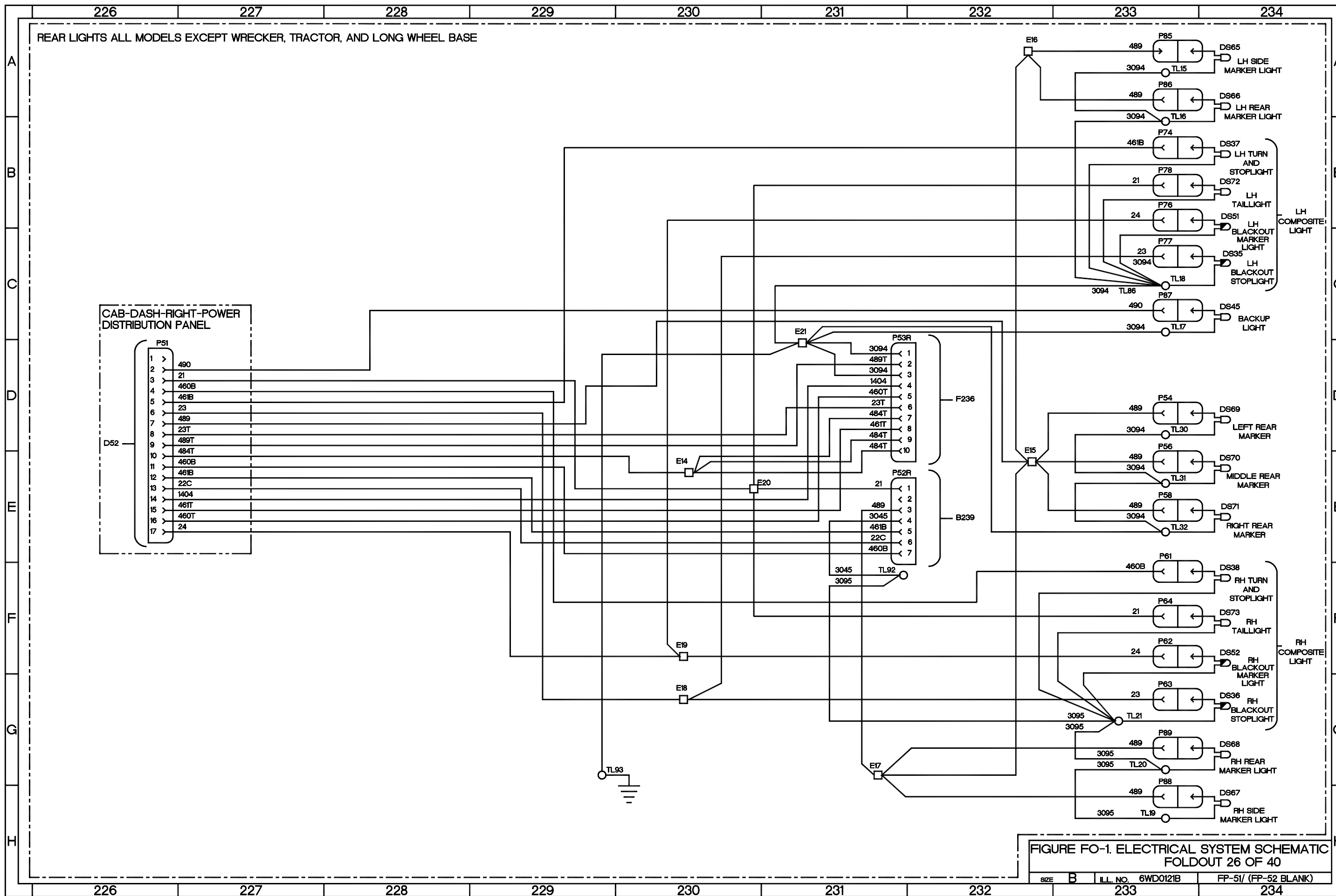

FIGURE FO-1. ELECTRICAL SYSTEM SCHEMATIC FOLDOUT 26 OF 40
 SIZE B ILL. NO. 6WD0121B FP-51/ (FP-52 BLANK)

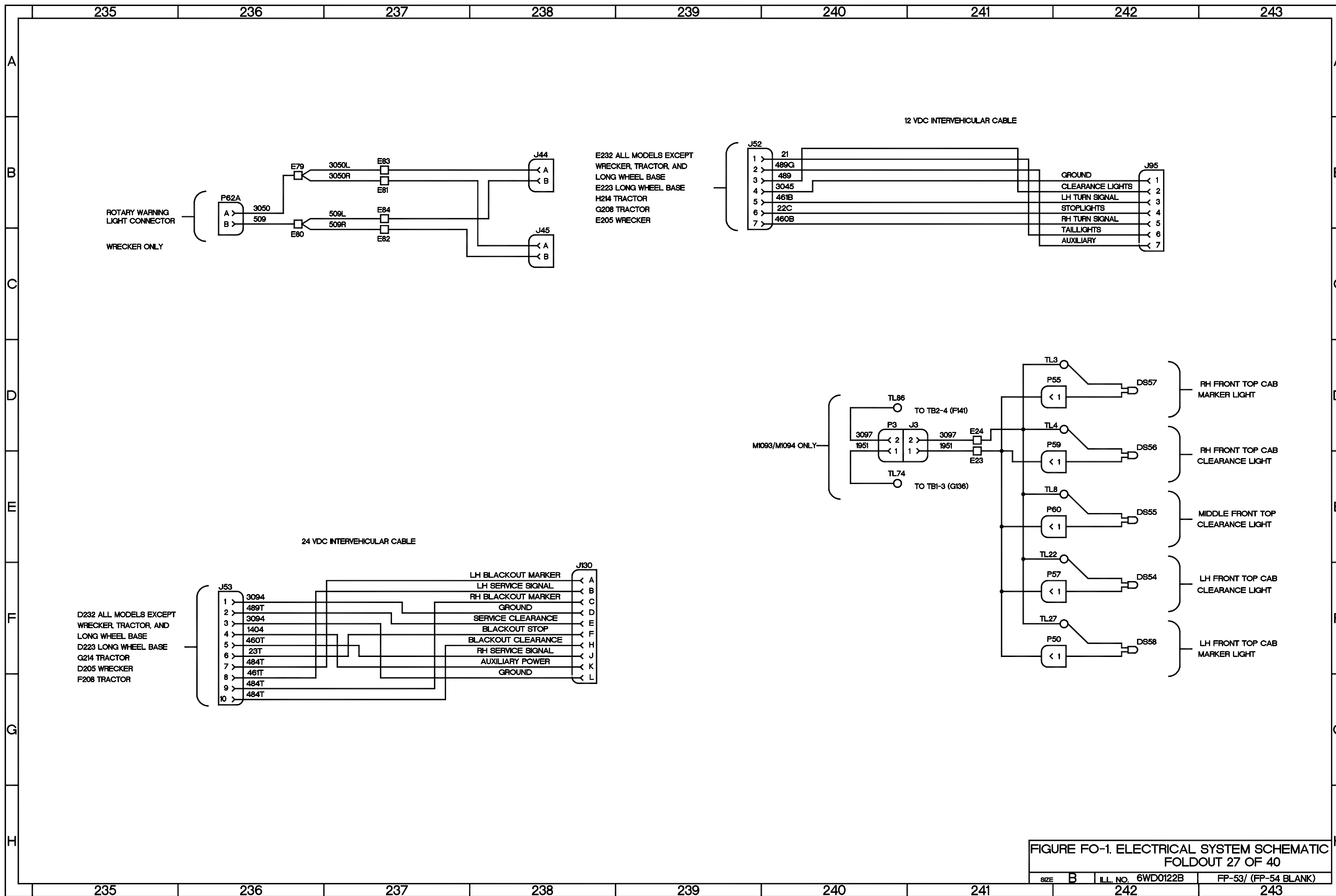

FIGURE FO-1. ELECTRICAL SYSTEM SCHEMATIC FOLDOUT 27 OF 40

SIZE	B	ILL. NO.	6WD0122B	FP-53/ (FP-54 BLANK)
------	---	----------	----------	----------------------

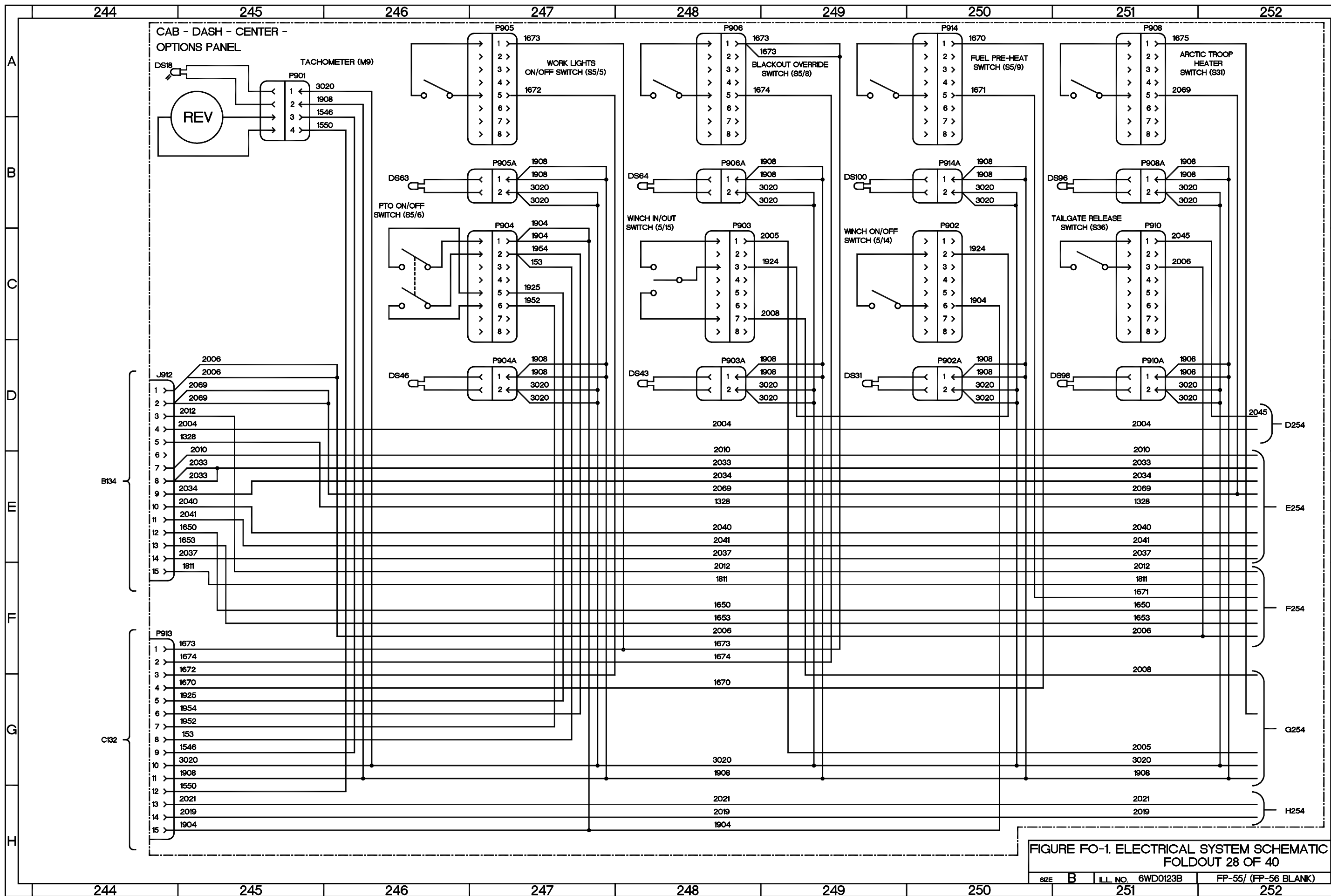

FIGURE FO-1. ELECTRICAL SYSTEM SCHEMATIC FOLDOUT 28 OF 40
 SIZE B ILL. NO. 6WD0123B FP-55/ (FP-56 BLANK)

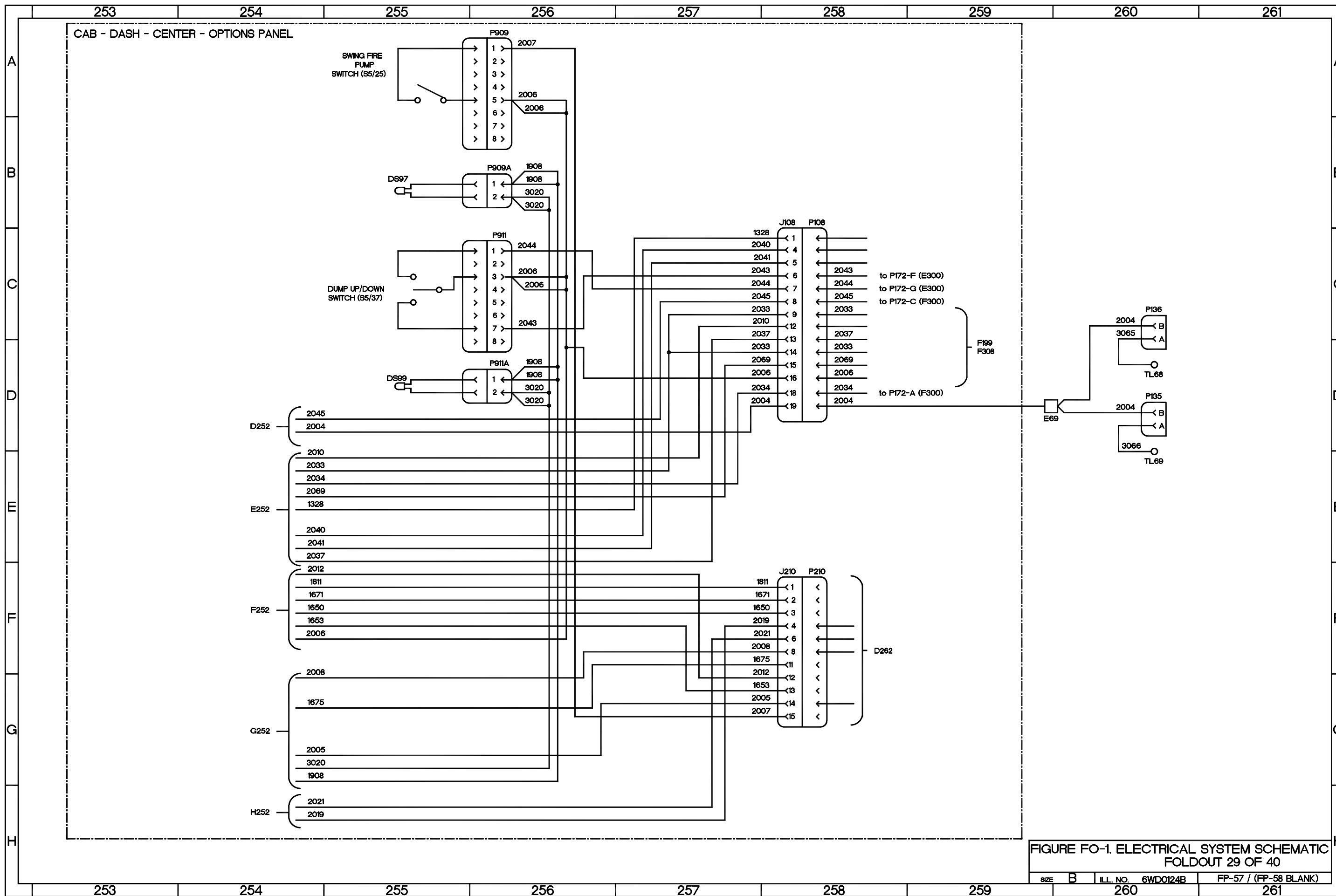

FIGURE FO-1. ELECTRICAL SYSTEM SCHEMATIC FOLDOUT 29 OF 40

SIZE	B	ILL. NO.	6WD0124B	FP-57 / (FP-58 BLANK)
------	---	----------	----------	-----------------------

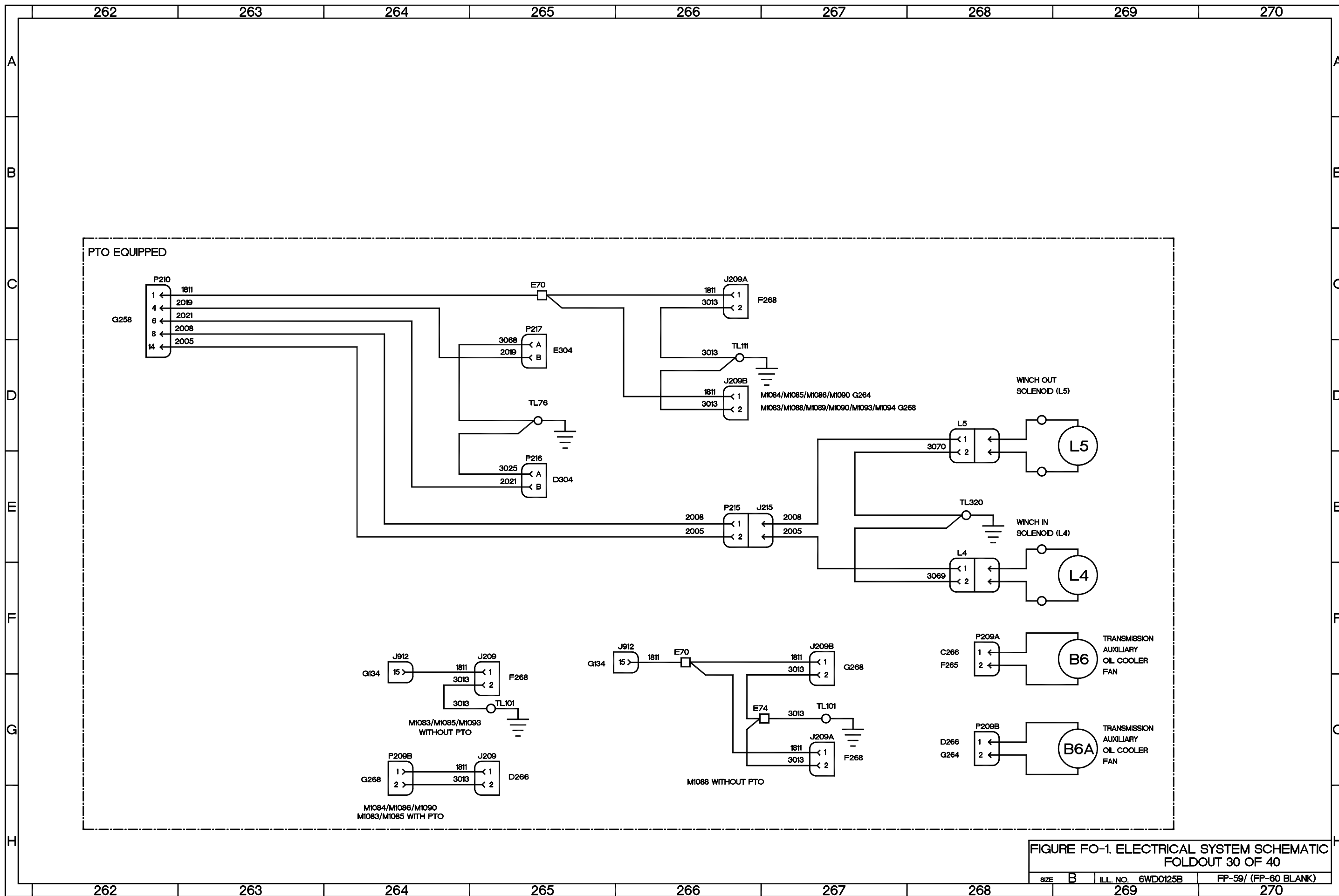

FIGURE FO-1. ELECTRICAL SYSTEM SCHEMATIC FOLDOUT 30 OF 40

SIZE	B	ILL. NO.	6WD0125B	FP-59/ (FP-60 BLANK)
------	---	----------	----------	----------------------







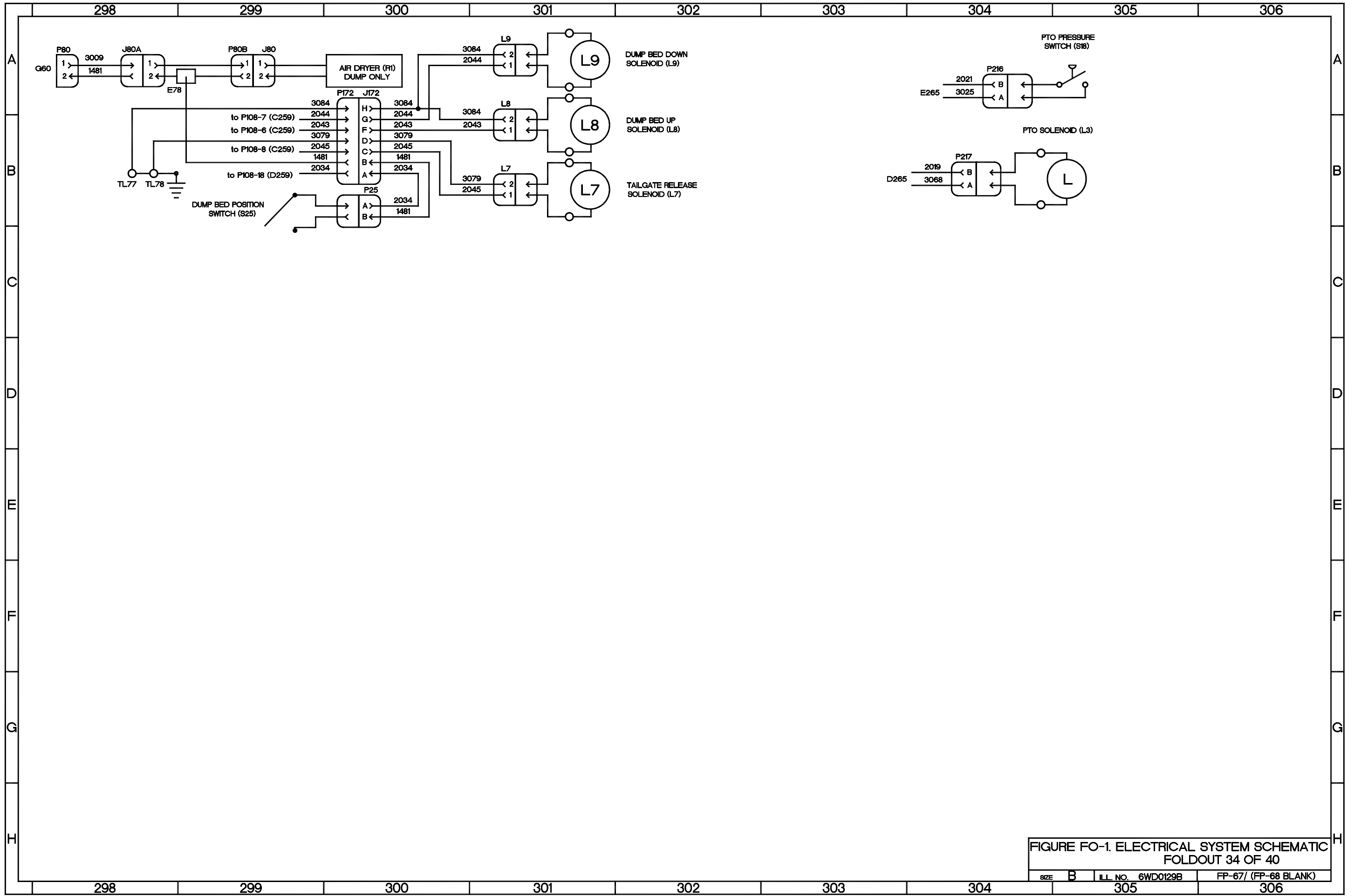

FIGURE FO-1. ELECTRICAL SYSTEM SCHEMATIC FOLDOUT 34 OF 40

SIZE	B	ILL. NO.	6WD0129B	FP-67/ (FP-68 BLANK)
------	---	----------	----------	----------------------

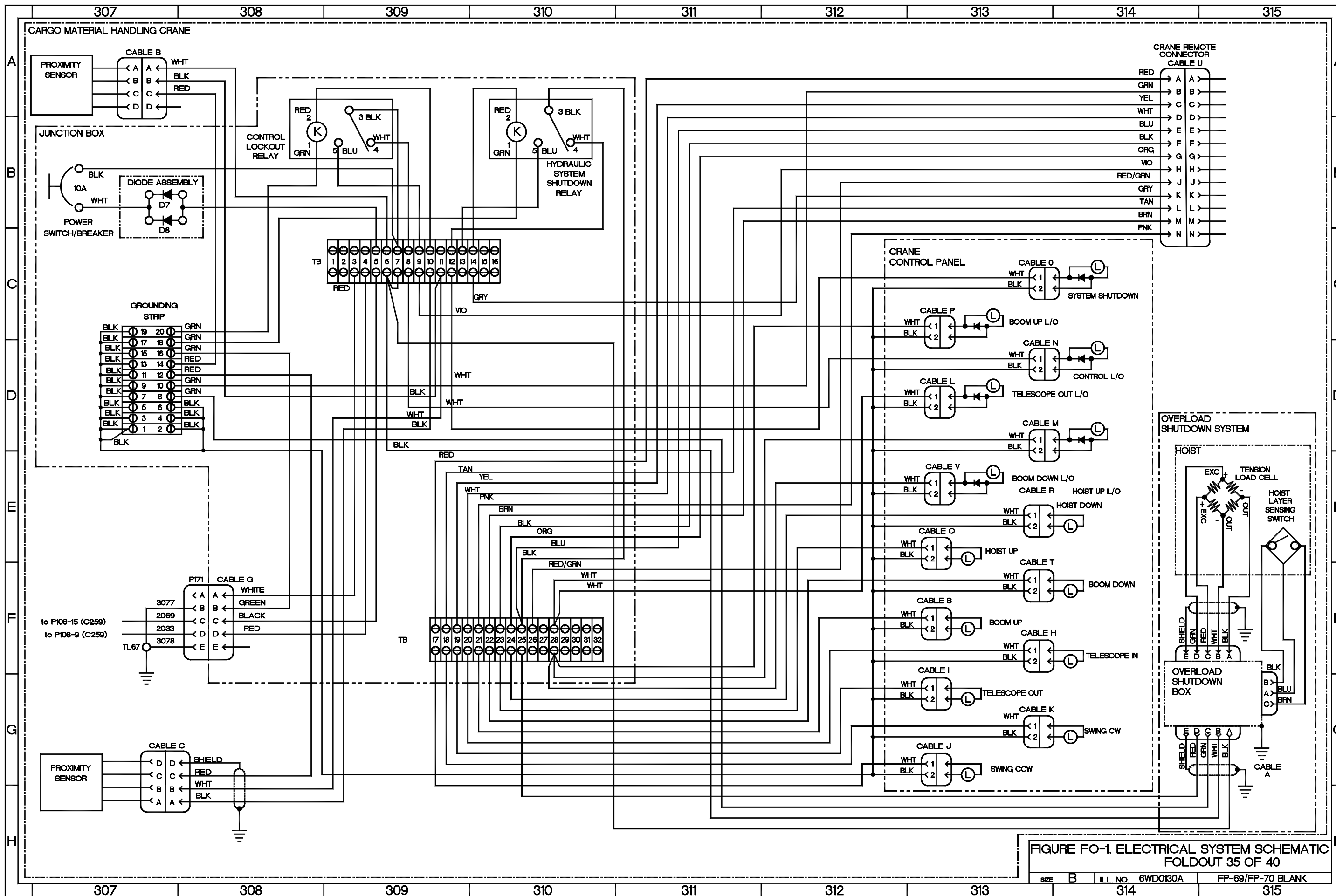

FIGURE FO-1. ELECTRICAL SYSTEM SCHEMATIC FOLDOUT 35 OF 40

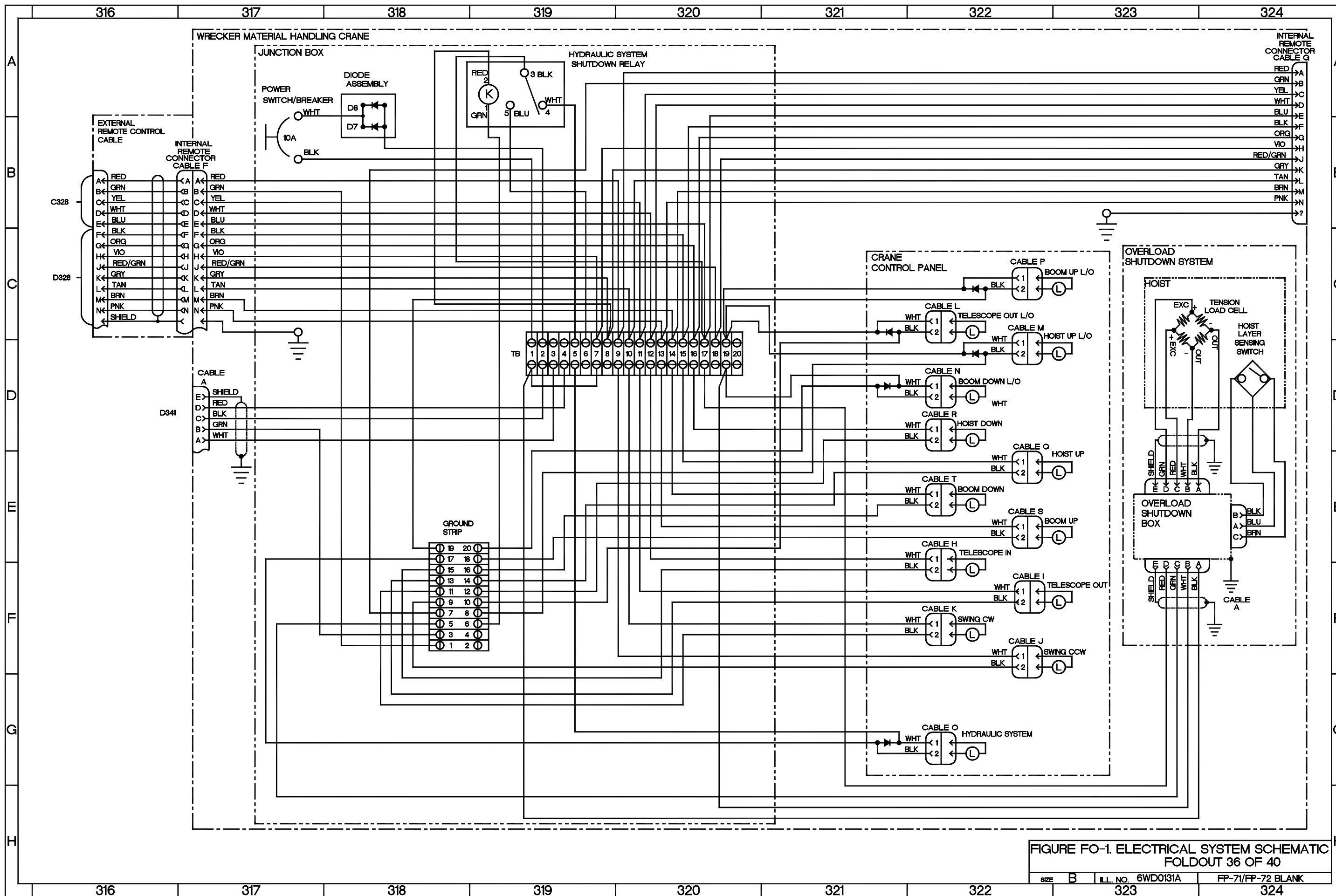

FIGURE FO-1. ELECTRICAL SYSTEM SCHEMATIC FOLDOUT 36 OF 40

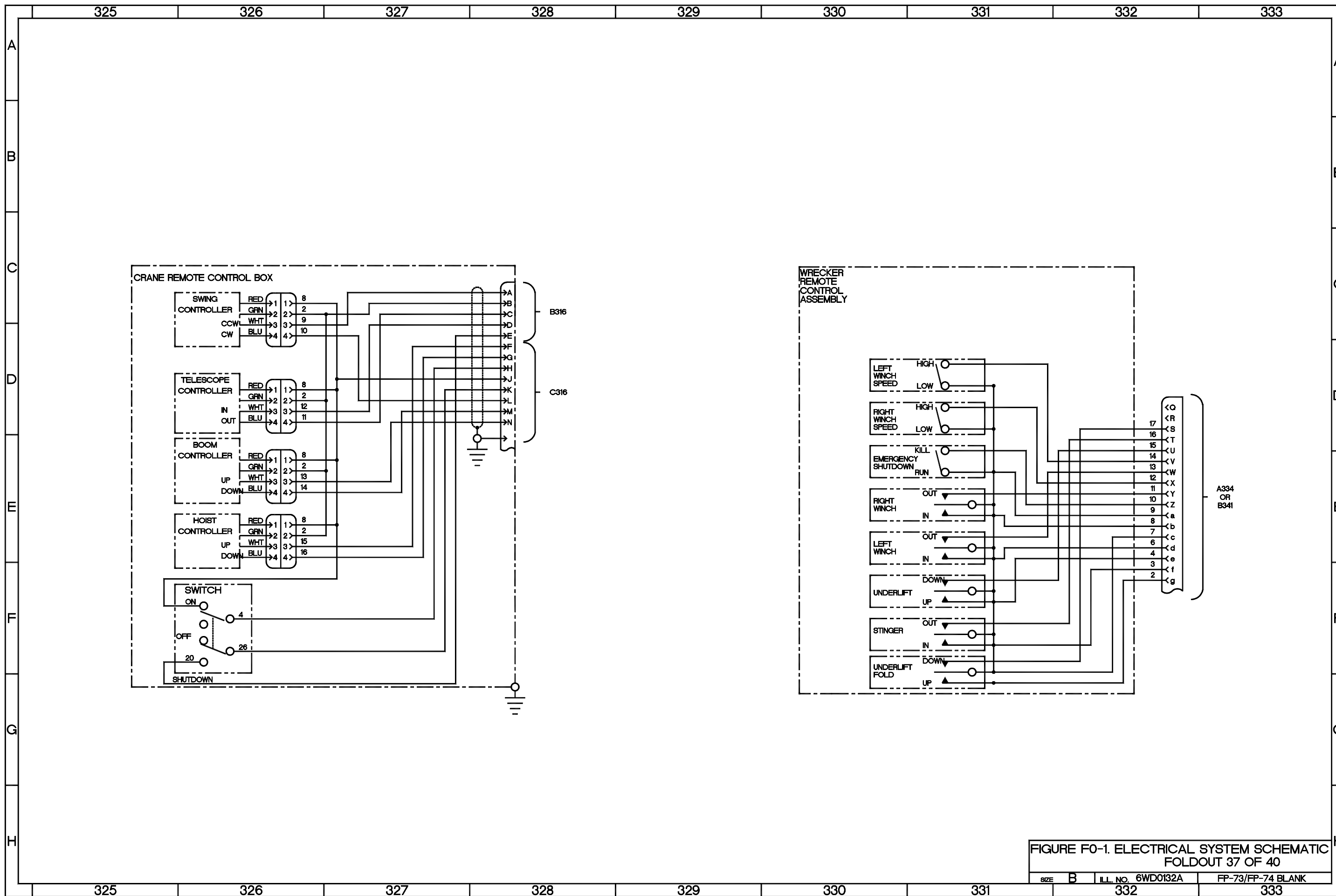

FIGURE FO-1. ELECTRICAL SYSTEM SCHEMATIC FOLDOUT 37 OF 40

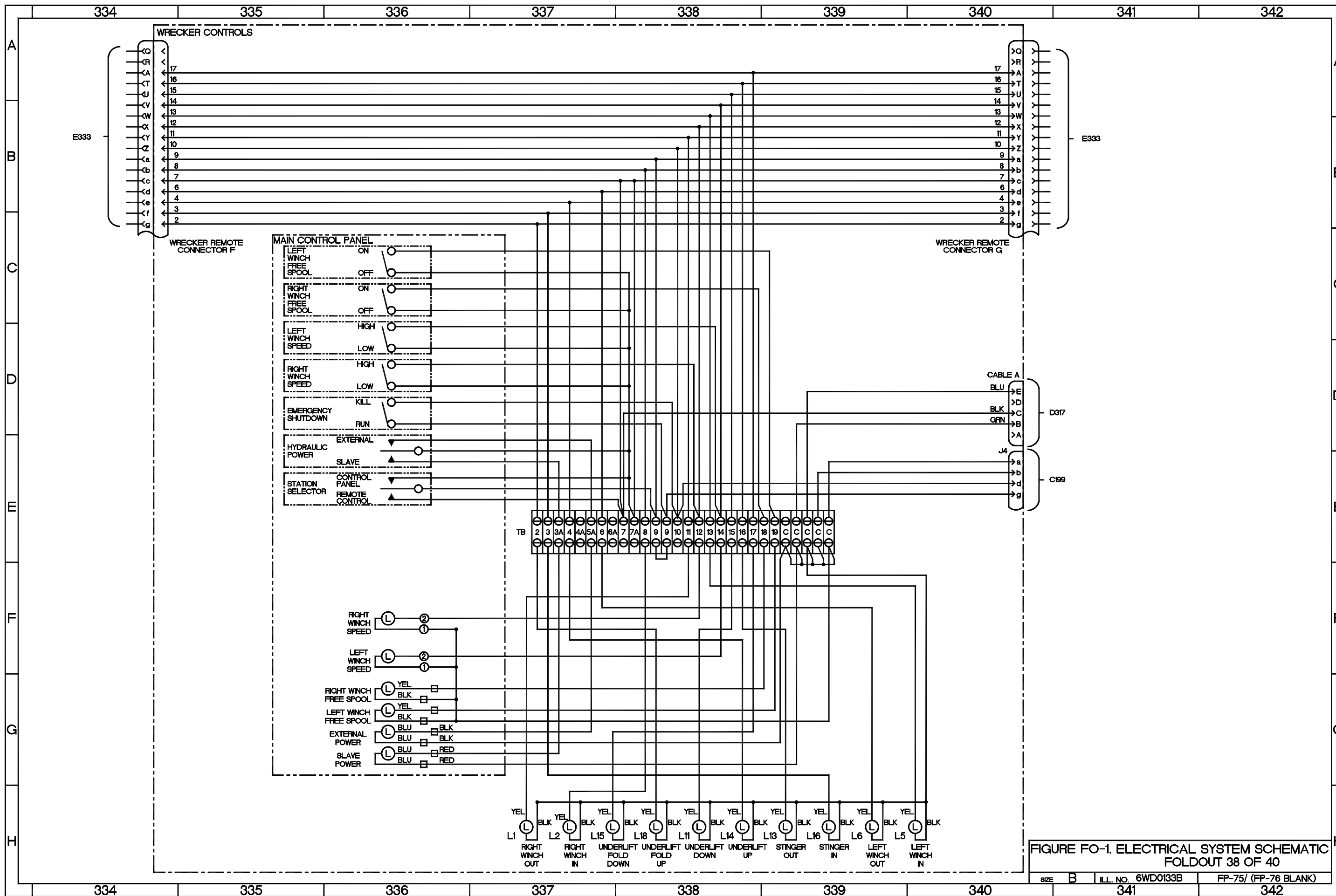

FIGURE FO-1. ELECTRICAL SYSTEM SCHEMATIC FOLDOUT 38 OF 40

SIZE B	ILL. NO. 6WD0133B	FP-75/ (FP-76 BLANK)
--------	-------------------	----------------------

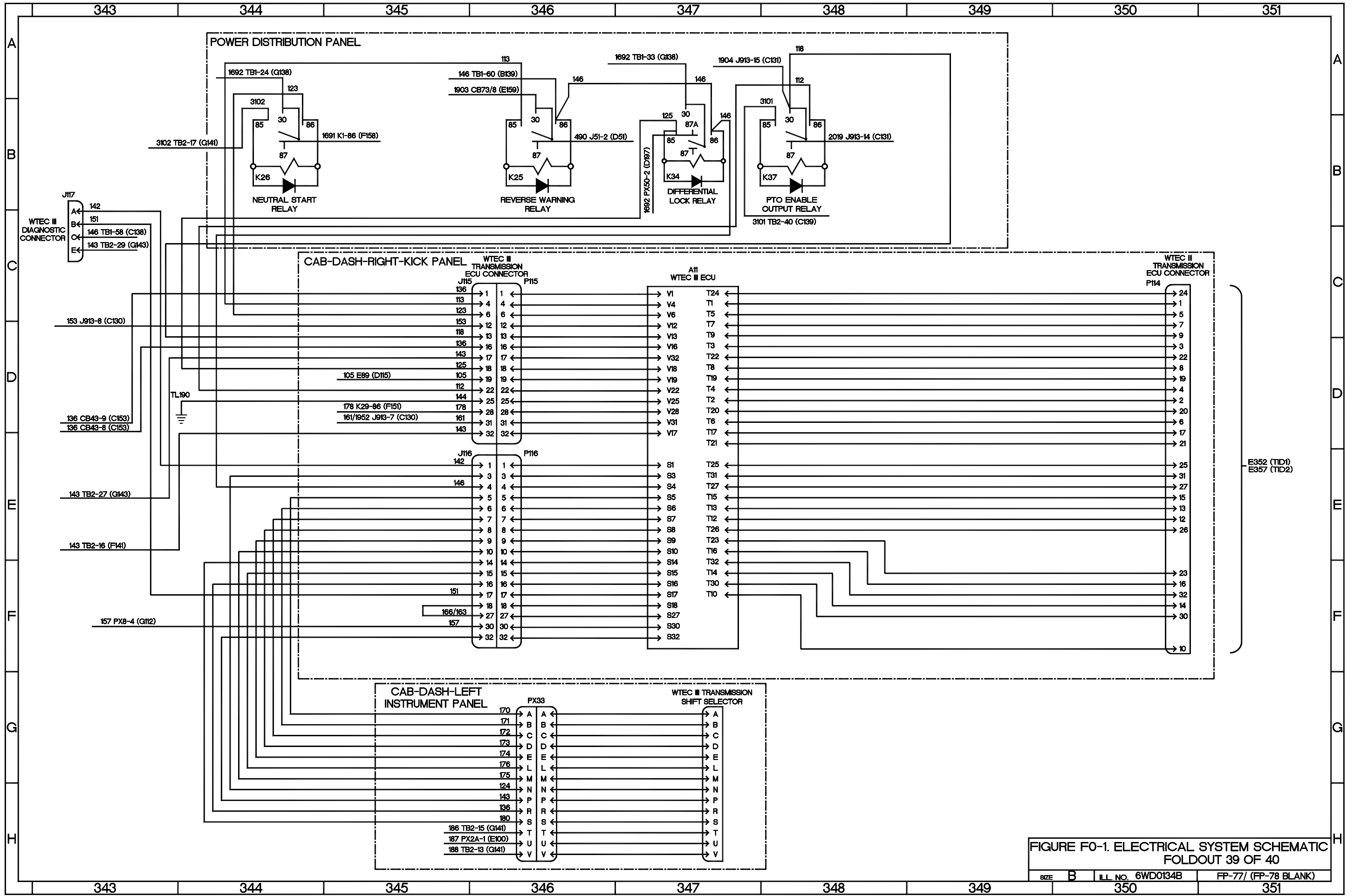
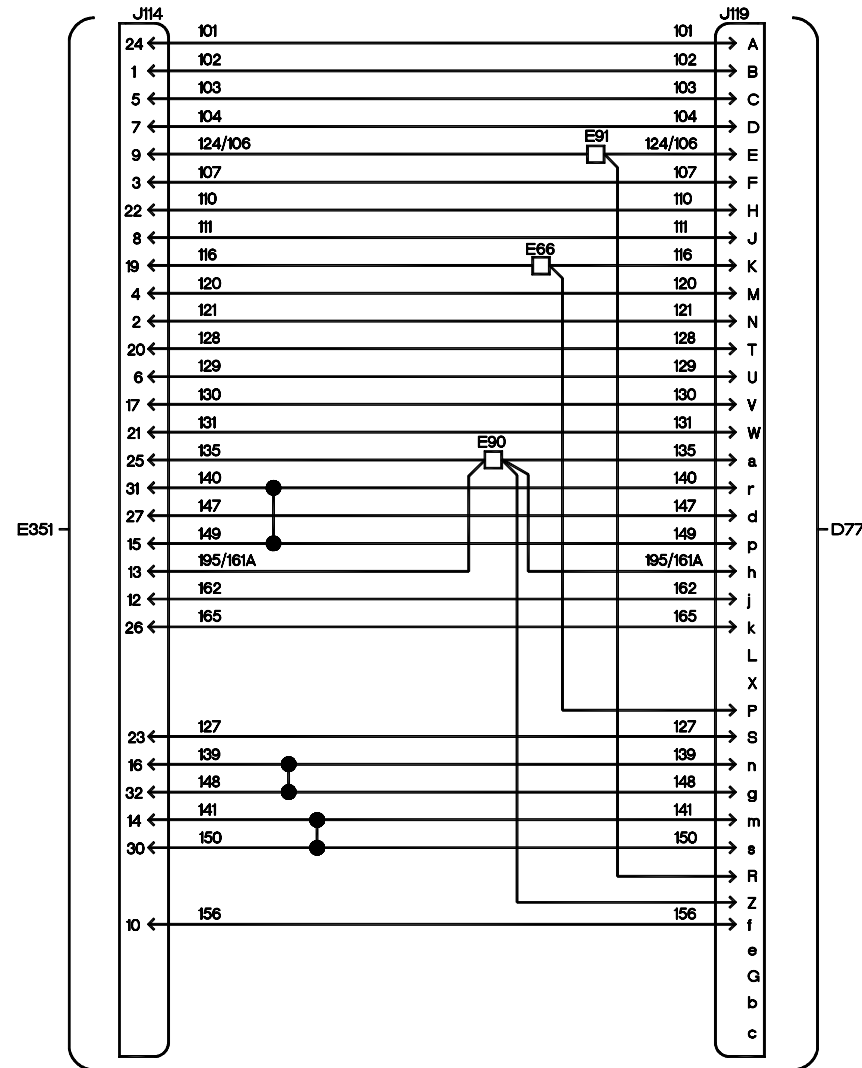

FIGURE FO-1. ELECTRICAL SYSTEM SCHEMATIC FOLDOUT 39 OF 40

SIZE B ILL. NO. 6WD0134B FP-77/ (FP-78 BLANK)

TRANSMISSION SERIAL #: 6510090785 AND LOWER

WTEC III CAB TRANSMISSION HARNESS (TID1)



TRANSMISSION SERIAL #: 6510090786 AND HIGHER

WTEC III CAB TRANSMISSION HARNESS (TID2)

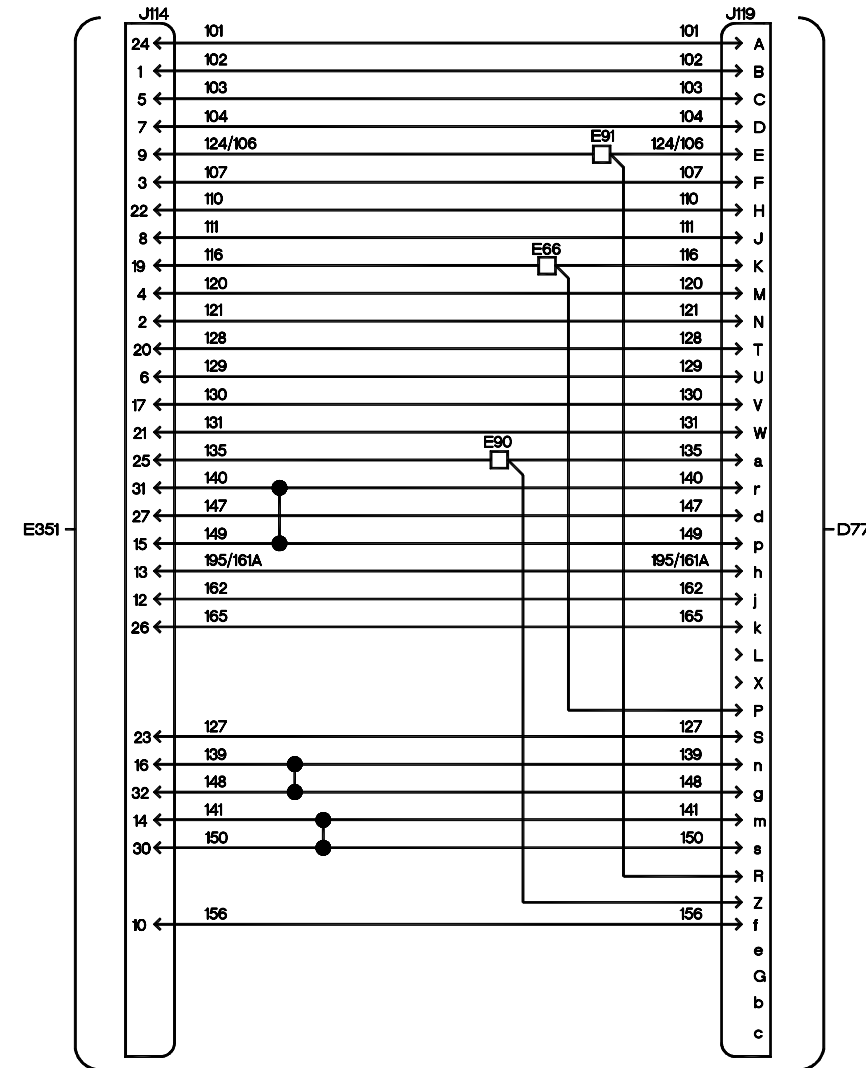

FIGURE FO-1. ELECTRICAL SYSTEM SCHEMATIC FOLDOUT 40 OF 40

SIZE B ILL. NO. 6WD0135B FP-79/ (FP-80 BLANK)











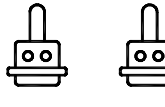
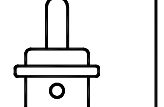
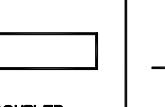
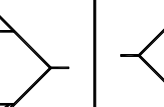
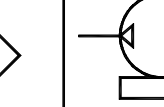
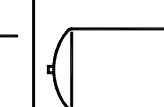
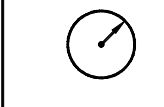

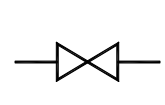
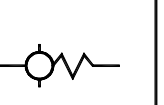
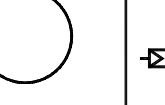
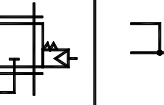
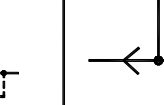
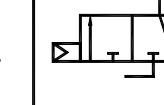
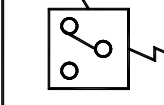



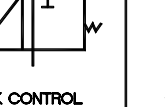

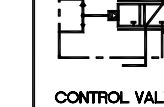
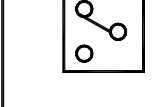

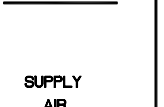
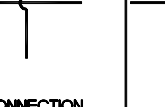
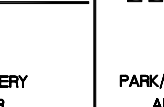

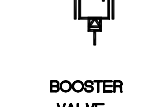

	1	2	3	4	5	6	7	8	9
A									
B	 REAR AXLE BRAKE CHAMBER	 FRONT AXLE BRAKE CHAMBER	 COUPLER AIR BRAKE	 AIR DRYER	 AIR CLEANER INTAKE	 AIR COMPRESSOR WITH GOVERNOR	 AIR TANK	 DASH GAUGE	
C	 MANUAL VALVE	 ONE WAY CHECK VALVE	 FAN CLUTCH	 MODULATED CONTROL VALVE	 QUICK RELEASE VALVE	 TWO WAY CHECK VALVE	 3/2 WAY SOLENOID VALVE	 PRESSURE SWITCH	
D	 PRESSURE RELIEF VALVE	 FOOT CONTROL VALVE	 PARK CONTROL VALVE (HAND OPERATED)	 TRAILER AIR SUPPLY VALVE (HAND OPERATED)	 LOAD SENSING VALVE (MECHANICALLY CONTROLLED)	 DIRECTIONAL RELAY VALVE	 CONTROL VALVE WITH TWO WAY CHECK VALVE	 STOPLIGHT SWITCH	
E	 CONNECTION	 SUPPLY AIR HOSE	 NO CONNECTION	 DELIVERY AIR HOSE	 PARK/EMERGENCY AIR HOSE	 AIR BRAKE PROTECTING VALVE	 INTERMEDIATE DIFFERENTIAL	 AIR BRAKE PRESSURE TRANSMITTER	
F	 BOOSTER VALVE	 AIR/HYDRAULIC INVERSION VALVE	 DELIVERY AIR HOSE NO CONNECTION	 DUMP TAILGATE SOLENOID	 BLEED VALVE	 TAILGATE CYLINDER	 CTIS MANIFOLD VALVE	 WHEEL VALVE	
G	 KNEELING VALVE	 TIRE	 (SINGLE ACTING) CYLINDER RETURN SPRING	 2-POSITION SPRING OFFSET SOLENOID VALVE	 (DOUBLE ACTING) CYLINDER	 MANIFOLD VALVE	 2-POSITION SOLENOID VALVE		
H									

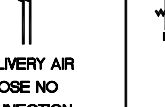
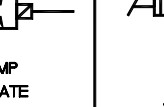
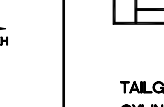
FIGURE F0-2 PNEUMATIC SYSTEM SCHEMATIC
FOLDOUT 1 OF 4

SIZE B ILL. NO. 6PD01A1 FP-1/FP-2 BLANK

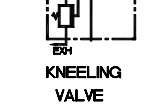

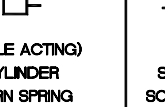
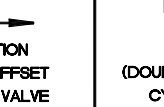
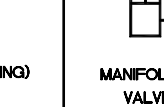
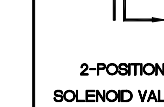
SH	ZONE	DESCRIPTION
3	E22	AIR BRAKE PRESSURE TRANSMITTER
3	F21	AIR BRAKE PRESSURE TRANSMITTER
3	A23	AIR BRAKE PROTECTING VALVE
3	F20	AIR COMPRESSOR
3	F20	AIR DRYER
3	B24	ANTI-COMPOUNDING VALVE
3	H23	BLEED VALVE
3	B21	BOOSTER VALVE
4	D30	CONTROL VALVE
4	C30	CTIS MANIFOLD VALVE
4	D31	DEFLATE VALVE
3	H20	DIFFERENTIAL LOCK SOLENOID
3	G24	DUMP TAILGATE SOLENOID
3	A25	EMERGENCY GLADHAND
3	A25	EMERGENCY GLADHAND
3	G19	EMERGENCY GLADHAND
3	H20	FAN CLUTCH
3	G20	FAN SOLENOID
3	C22	FOOT CONTROL VALVE
3	F20	INTAKE AIR CLEANER
3	H19	INTERMEDIATE AXLE DIFFERENTIAL
3	E23	INVERSION VALVE
3	G25	INVERSION VALVE
4	A28	KNEELING VALVE
4	C28	KNEELING VALVE
4	E28	LH MAIN WINCH FREESPOOL
4	E30	LH MAIN WINCH TENSIONER
4	G29	LH MAIN WINCH VALVE
3	C25	LOAD SENSING VALVE
3	E23	LOW PRESSURE SWITCH
3	F21	LOW PRESSURE SWITCH
4	F28	MANIFOLD
4	G29	MANIFOLD
3	F22	MANUAL VALVE
3	G21	MANUAL VALVE
3	G22	MANUAL VALVE
3	F22	ONE WAY CHECK VALVE
3	G20	ONE WAY CHECK VALVE
3	G22	ONE WAY CHECK VALVE
3	G21	PRESSURE PROTECTION VALVE
3	G22	PRIMARY AIR TANK
4	B30	QUICK RELEASE VALVE
4	B33	QUICK RELEASE VALVE
4	B36	QUICK RELEASE VALVE
3	C20	QUICK RELEASE VALVE
4	E30	REGULATOR
4	E31	REGULATOR

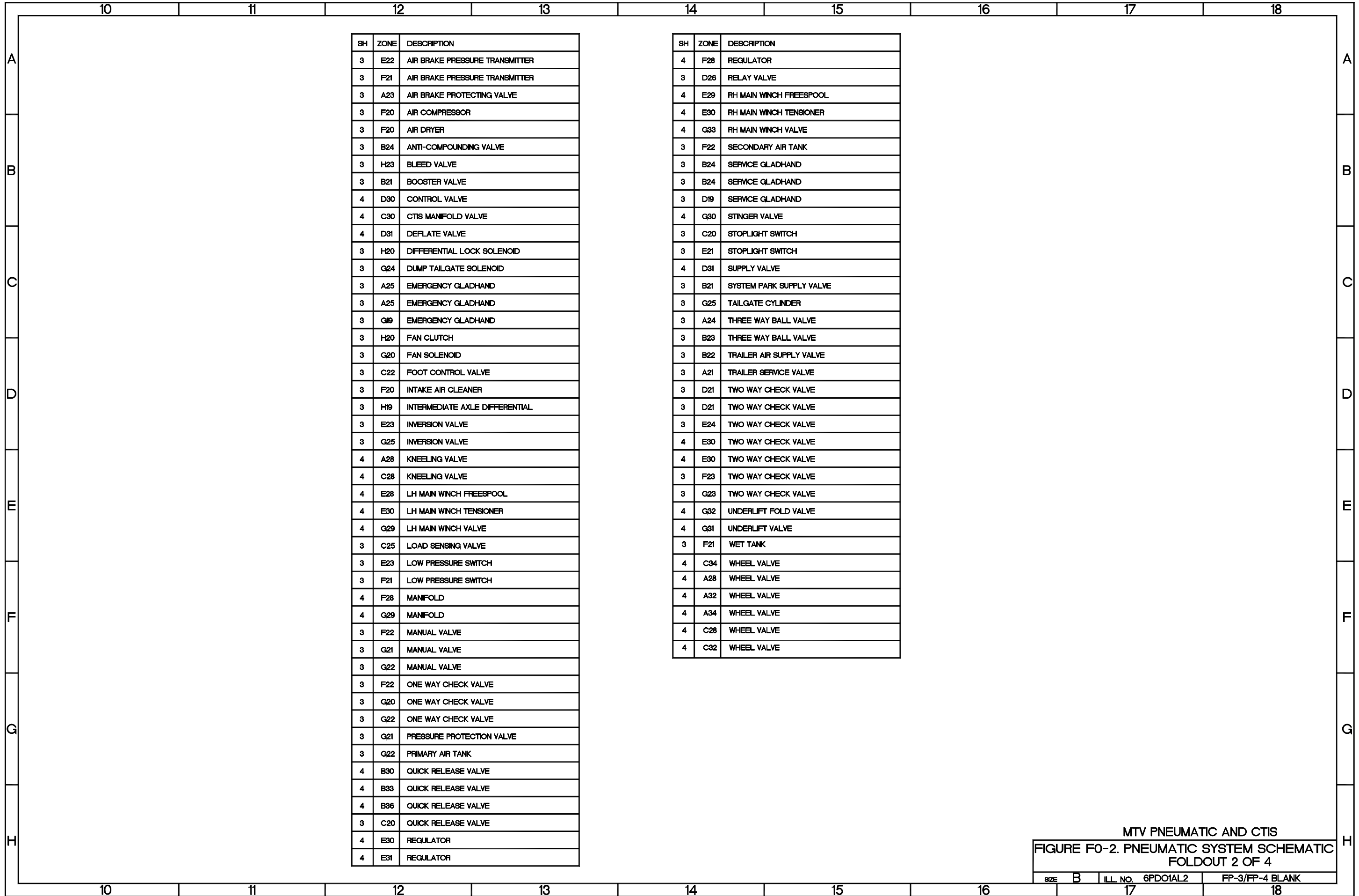
SH	ZONE	DESCRIPTION
4	F28	REGULATOR
3	D26	RELAY VALVE
4	E29	RH MAIN WINCH FREESPOOL
4	E30	RH MAIN WINCH TENSIONER
4	G33	RH MAIN WINCH VALVE
3	F22	SECONDARY AIR TANK
3	B24	SERVICE GLADHAND
3	B24	SERVICE GLADHAND
3	D19	SERVICE GLADHAND
4	G30	STINGER VALVE
3	C20	STOPLIGHT SWITCH
3	E21	STOPLIGHT SWITCH
4	D31	SUPPLY VALVE
3	B21	SYSTEM PARK SUPPLY VALVE
3	G25	TAILGATE CYLINDER
3	A24	THREE WAY BALL VALVE
3	B23	THREE WAY BALL VALVE
3	B22	TRAILER AIR SUPPLY VALVE
3	A21	TRAILER SERVICE VALVE
3	D21	TWO WAY CHECK VALVE
3	D21	TWO WAY CHECK VALVE
3	E24	TWO WAY CHECK VALVE
4	E30	TWO WAY CHECK VALVE
4	E30	TWO WAY CHECK VALVE
3	F23	TWO WAY CHECK VALVE
3	G23	TWO WAY CHECK VALVE
4	G32	UNDERLIFT FOLD VALVE
4	G31	UNDERLIFT VALVE
3	F21	WET TANK
4	C34	WHEEL VALVE
4	A28	WHEEL VALVE
4	A32	WHEEL VALVE
4	A34	WHEEL VALVE
4	C28	WHEEL VALVE
4	C32	WHEEL VALVE

MTV PNEUMATIC AND CTIS
 FIGURE FO-2. PNEUMATIC SYSTEM SCHEMATIC
 FOLDOUT 2 OF 4

SIZE B ILL. NO. 6PFO1A2 FP-3/FP-4 BLANK

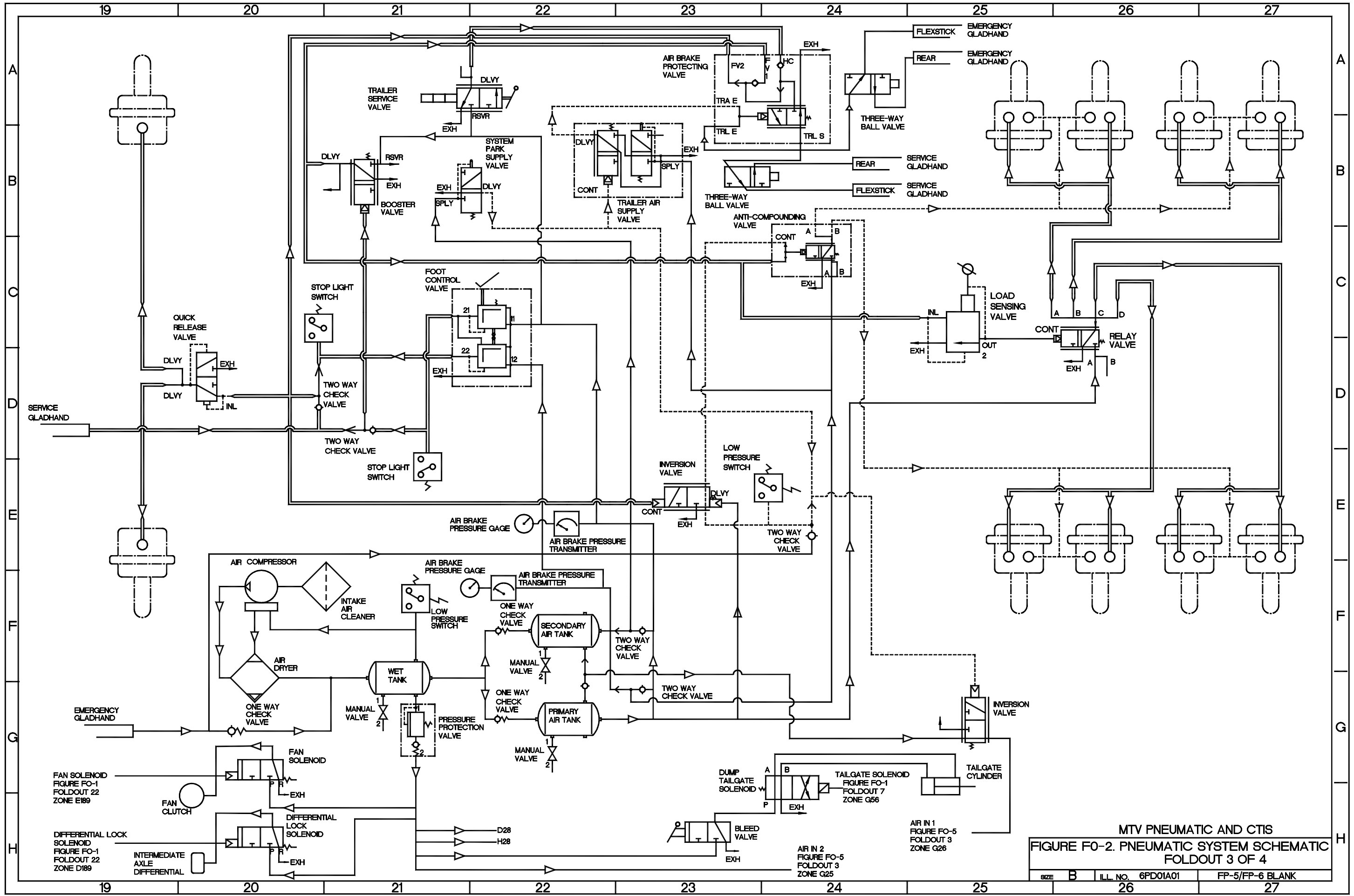

MTV PNEUMATIC AND CTIS
 FIGURE FO-2. PNEUMATIC SYSTEM SCHEMATIC
 FOLDOUT 3 OF 4

SIZE	B	ILL. NO.	6PD01A01	FP-5/FP-6	BLANK
------	---	----------	----------	-----------	-------

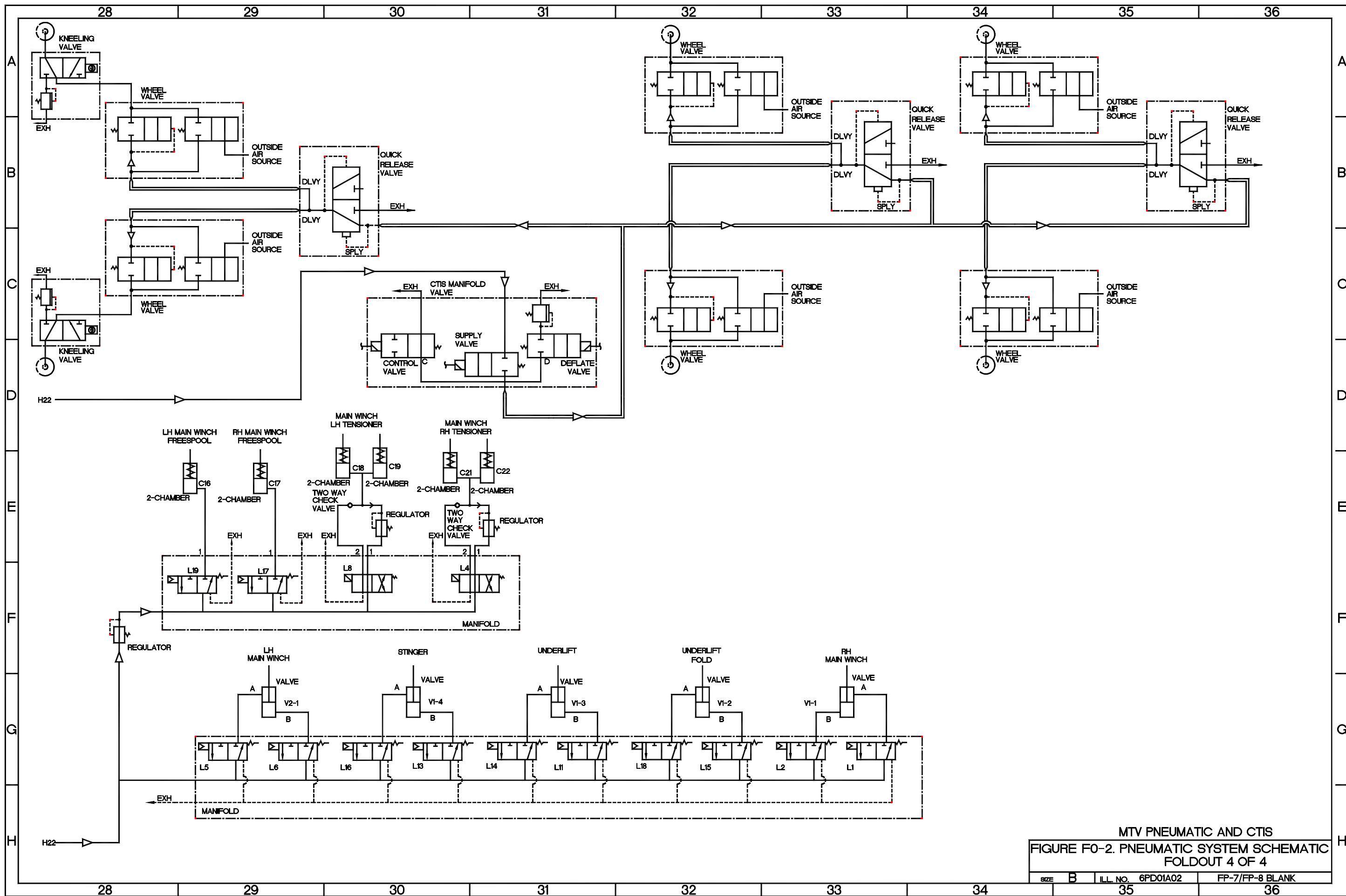

MTV PNEUMATIC AND CTIS
 FIGURE FO-2. PNEUMATIC SYSTEM SCHEMATIC
 FOLDOUT 4 OF 4

SIZE	B	ILL. NO.	6PD01A02	FP-7/FP-8	BLANK
------	---	----------	----------	-----------	-------

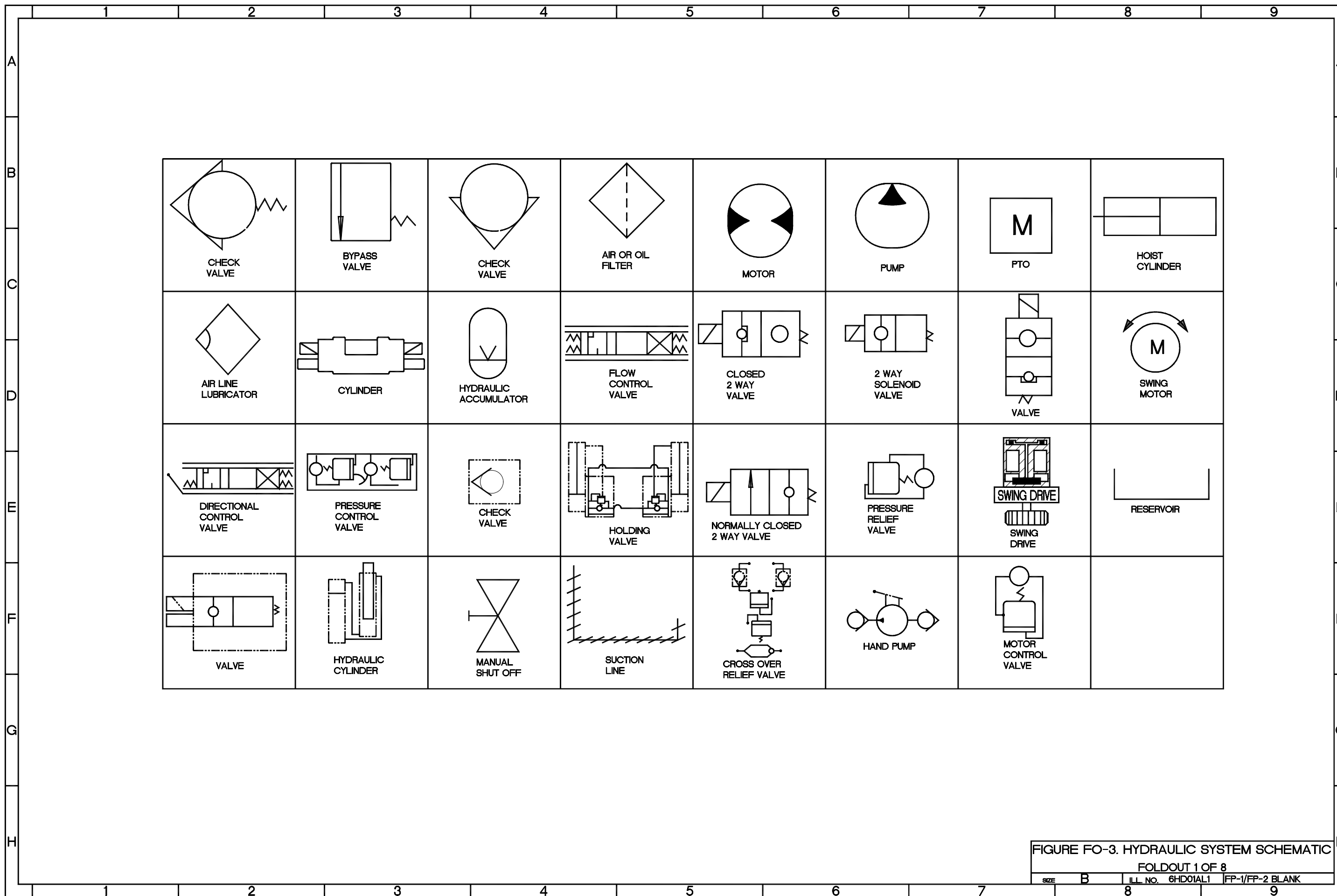

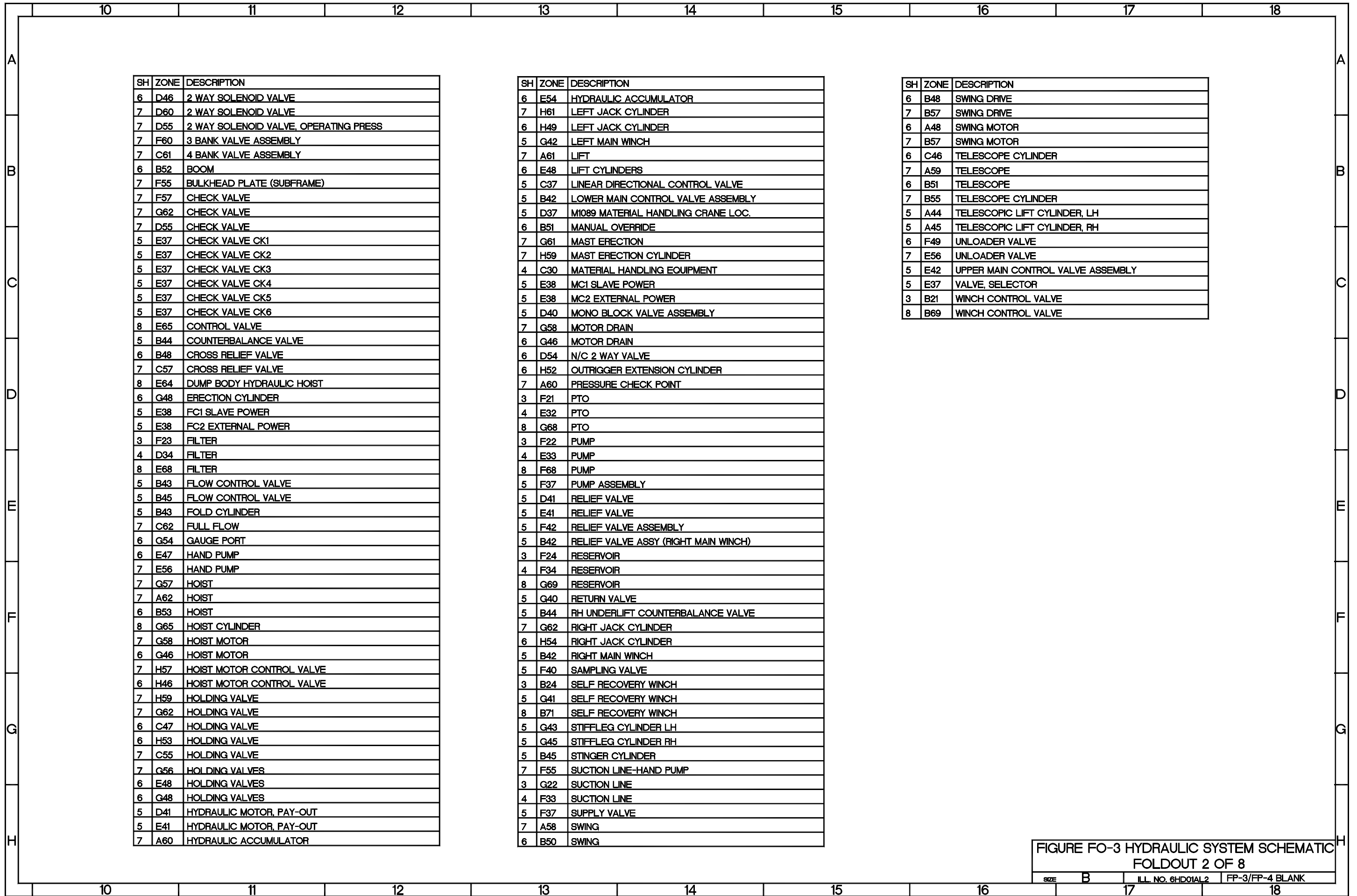

SH	ZONE	DESCRIPTION
6	D46	2 WAY SOLENOID VALVE
7	D60	2 WAY SOLENOID VALVE
7	D55	2 WAY SOLENOID VALVE, OPERATING PRESS
7	F60	3 BANK VALVE ASSEMBLY
7	C61	4 BANK VALVE ASSEMBLY
6	B52	BOOM
7	F55	BULKHEAD PLATE (SUBFRAME)
7	F57	CHECK VALVE
7	G62	CHECK VALVE
7	D55	CHECK VALVE
5	E37	CHECK VALVE CK1
5	E37	CHECK VALVE CK2
5	E37	CHECK VALVE CK3
5	E37	CHECK VALVE CK4
5	E37	CHECK VALVE CK5
5	E37	CHECK VALVE CK6
8	E65	CONTROL VALVE
5	B44	COUNTERBALANCE VALVE
6	B48	CROSS RELIEF VALVE
7	C57	CROSS RELIEF VALVE
8	E64	DUMP BODY HYDRAULIC HOIST
6	G48	ERECTION CYLINDER
5	E38	FC1 SLAVE POWER
5	E38	FC2 EXTERNAL POWER
3	F23	FILTER
4	D34	FILTER
8	E68	FILTER
5	B43	FLOW CONTROL VALVE
5	B45	FLOW CONTROL VALVE
5	B43	FOLD CYLINDER
7	C62	FULL FLOW
6	G54	GAUGE PORT
6	E47	HAND PUMP
7	E56	HAND PUMP
7	G57	HOIST
7	A62	HOIST
6	B53	HOIST
8	G65	HOIST CYLINDER
7	G58	HOIST MOTOR
6	G46	HOIST MOTOR
7	H57	HOIST MOTOR CONTROL VALVE
6	H46	HOIST MOTOR CONTROL VALVE
7	H59	HOLDING VALVE
7	G62	HOLDING VALVE
6	C47	HOLDING VALVE
6	H53	HOLDING VALVE
7	C55	HOLDING VALVE
7	G56	HOLDING VALVES
6	E48	HOLDING VALVES
6	G48	HOLDING VALVES
5	D41	HYDRAULIC MOTOR, PAY-OUT
5	E41	HYDRAULIC MOTOR, PAY-OUT
7	A60	HYDRAULIC ACCUMULATOR

SH	ZONE	DESCRIPTION
6	E54	HYDRAULIC ACCUMULATOR
7	H61	LEFT JACK CYLINDER
6	H49	LEFT JACK CYLINDER
5	G42	LEFT MAIN WINCH
7	A61	LIFT
6	E48	LIFT CYLINDERS
5	C37	LINEAR DIRECTIONAL CONTROL VALVE
5	B42	LOWER MAIN CONTROL VALVE ASSEMBLY
5	D37	M1089 MATERIAL HANDLING CRANE LOC.
6	B51	MANUAL OVERRIDE
7	G61	MAST ERECTION
7	H59	MAST ERECTION CYLINDER
4	C30	MATERIAL HANDLING EQUIPMENT
5	E38	MC1 SLAVE POWER
5	E38	MC2 EXTERNAL POWER
5	D40	MONO BLOCK VALVE ASSEMBLY
7	G58	MOTOR DRAIN
6	G46	MOTOR DRAIN
6	D54	N/C 2 WAY VALVE
6	H52	OUTRIGGER EXTENSION CYLINDER
7	A60	PRESSURE CHECK POINT
3	F21	PTO
4	E32	PTO
8	G68	PTO
3	F22	PUMP
4	E33	PUMP
8	F68	PUMP
5	F37	PUMP ASSEMBLY
5	D41	RELIEF VALVE
5	E41	RELIEF VALVE
5	F42	RELIEF VALVE ASSEMBLY
5	B42	RELIEF VALVE ASSY (RIGHT MAIN WINCH)
3	F24	RESERVOIR
4	F34	RESERVOIR
8	G69	RESERVOIR
5	G40	RETURN VALVE
5	B44	RH UNDERLIFT COUNTERBALANCE VALVE
7	G62	RIGHT JACK CYLINDER
6	H54	RIGHT JACK CYLINDER
5	B42	RIGHT MAIN WINCH
5	F40	SAMPLING VALVE
3	B24	SELF RECOVERY WINCH
5	G41	SELF RECOVERY WINCH
8	B71	SELF RECOVERY WINCH
5	G43	STIFFLEG CYLINDER LH
5	G45	STIFFLEG CYLINDER RH
5	B45	STINGER CYLINDER
7	F55	SUCTION LINE-HAND PUMP
3	G22	SUCTION LINE
4	F33	SUCTION LINE
5	F37	SUPPLY VALVE
7	A58	SWING
6	B50	SWING

SH	ZONE	DESCRIPTION
6	B48	SWING DRIVE
7	B57	SWING DRIVE
6	A48	SWING MOTOR
7	B57	SWING MOTOR
6	C46	TELESCOPE CYLINDER
7	A59	TELESCOPE
6	B51	TELESCOPE
7	B55	TELESCOPE CYLINDER
5	A44	TELESCOPIC LIFT CYLINDER, LH
5	A45	TELESCOPIC LIFT CYLINDER, RH
6	F49	UNLOADER VALVE
7	E56	UNLOADER VALVE
5	E42	UPPER MAIN CONTROL VALVE ASSEMBLY
5	E37	VALVE, SELECTOR
3	B21	WINCH CONTROL VALVE
8	B69	WINCH CONTROL VALVE

FIGURE FO-3 HYDRAULIC SYSTEM SCHEMATIC
FOLDOUT 2 OF 8

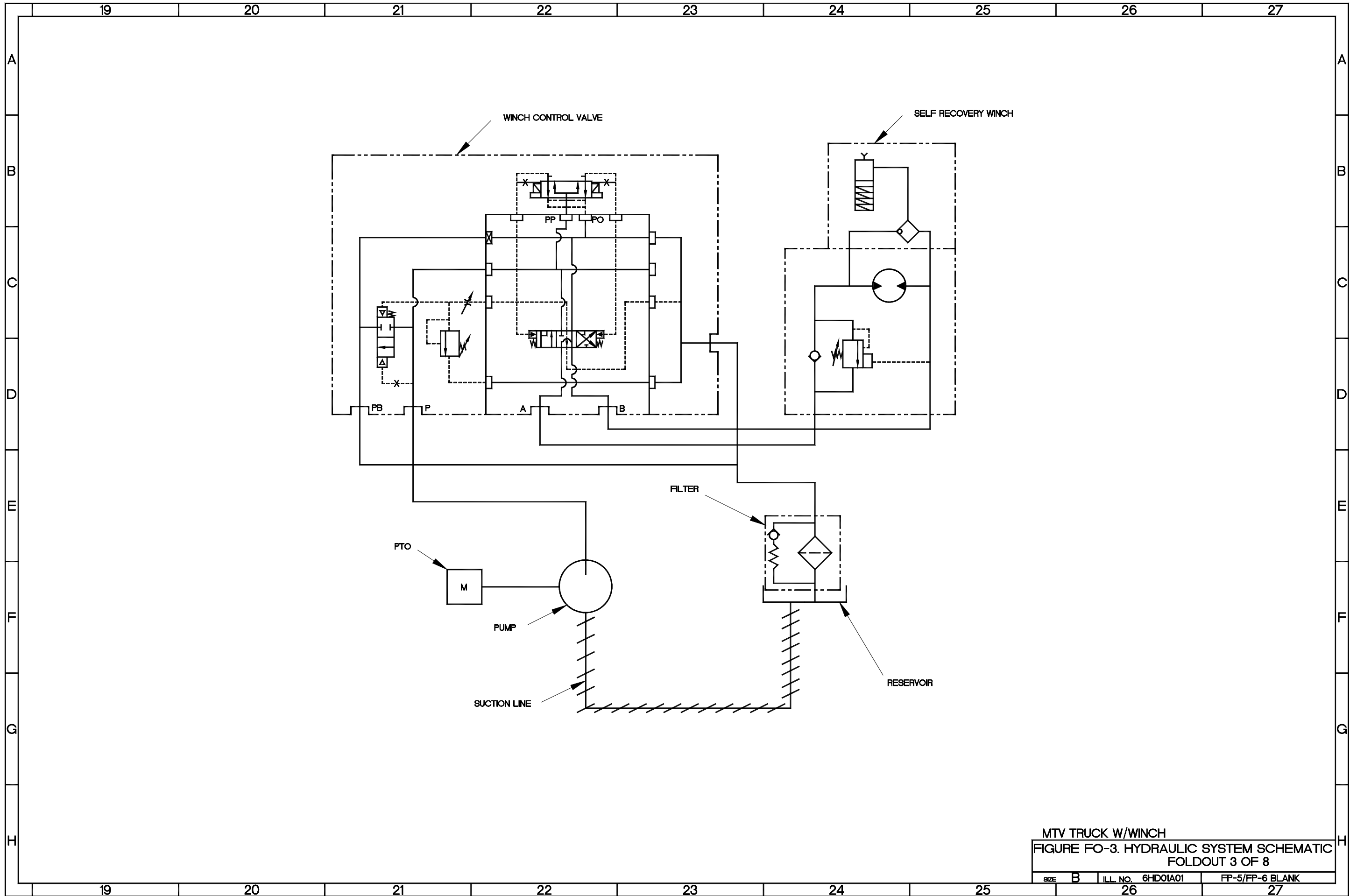

MTV TRUCK W/WINCH
 FIGURE FO-3. HYDRAULIC SYSTEM SCHEMATIC
 FOLDOUT 3 OF 8

SIZE	B	ILL. NO.	6HD01A01	FP-5/FP-6	BLANK
------	---	----------	----------	-----------	-------

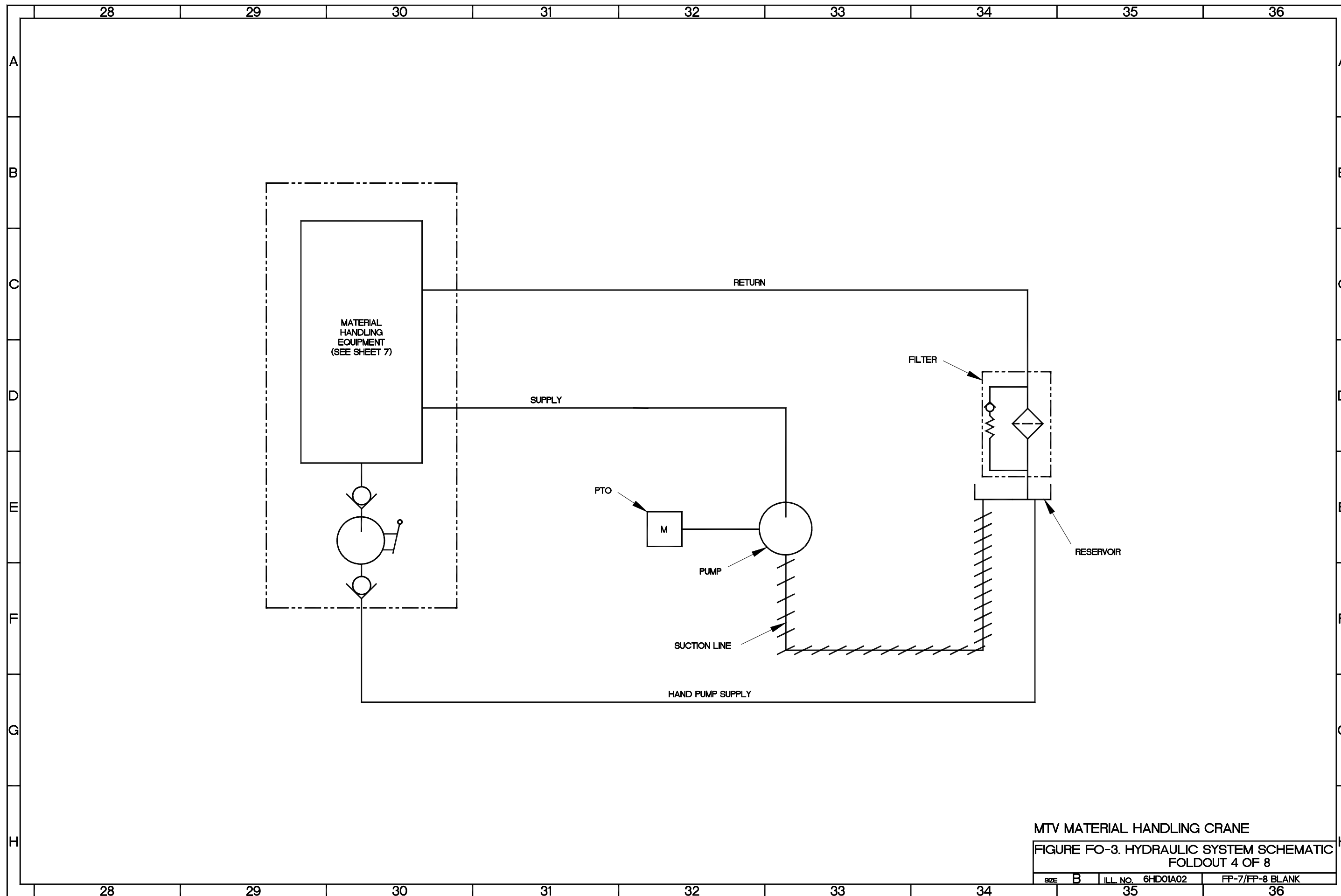

MTV MATERIAL HANDLING CRANE
 FIGURE FO-3. HYDRAULIC SYSTEM SCHEMATIC
 FOLDOUT 4 OF 8

SIZE	B	ILL. NO.	6HD01A02	FP-7/FP-8	BLANK
------	---	----------	----------	-----------	-------

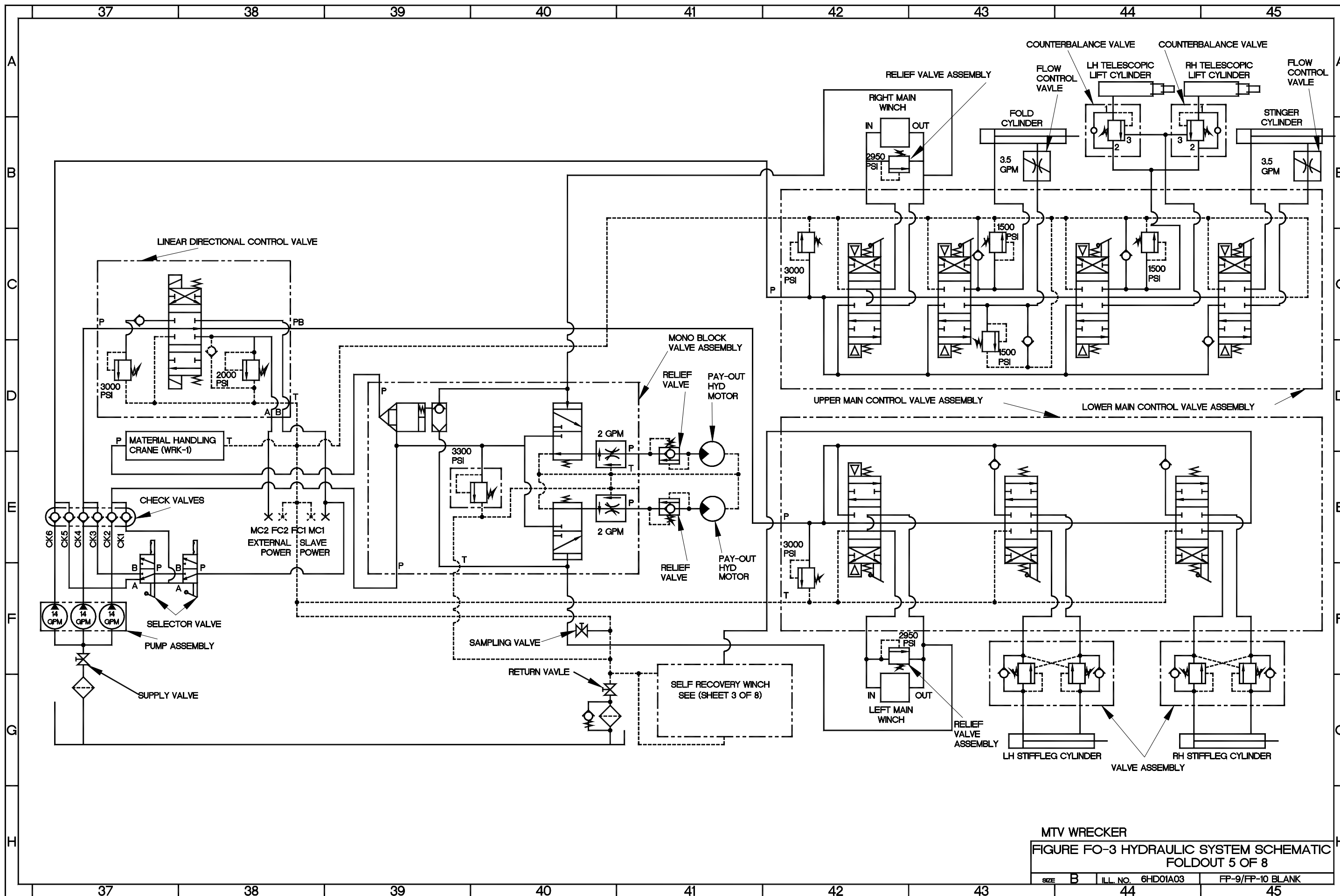

MTV WRECKER
 FIGURE FO-3 HYDRAULIC SYSTEM SCHEMATIC
 FOLDOUT 5 OF 8
 SIZE B ILL. NO. 6HD01A03 FP-9/FP-10 BLANK

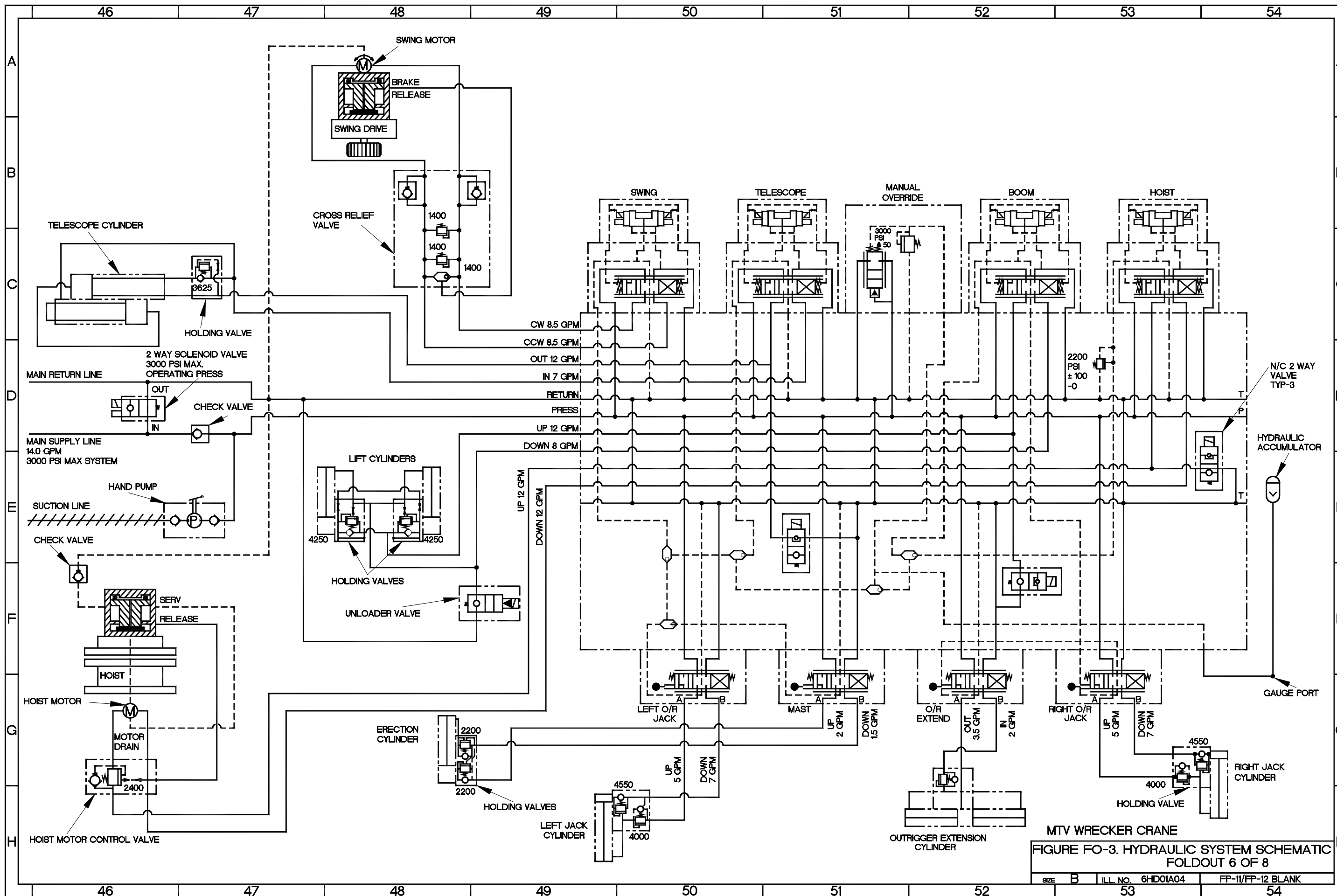

MTV WRECKER CRANE
 FIGURE FO-3. HYDRAULIC SYSTEM SCHEMATIC
 FOLDOUT 6 OF 8

SIZE	B	ILL. NO.	6HD01A04	FP-11/FP-12	BLANK
------	---	----------	----------	-------------	-------

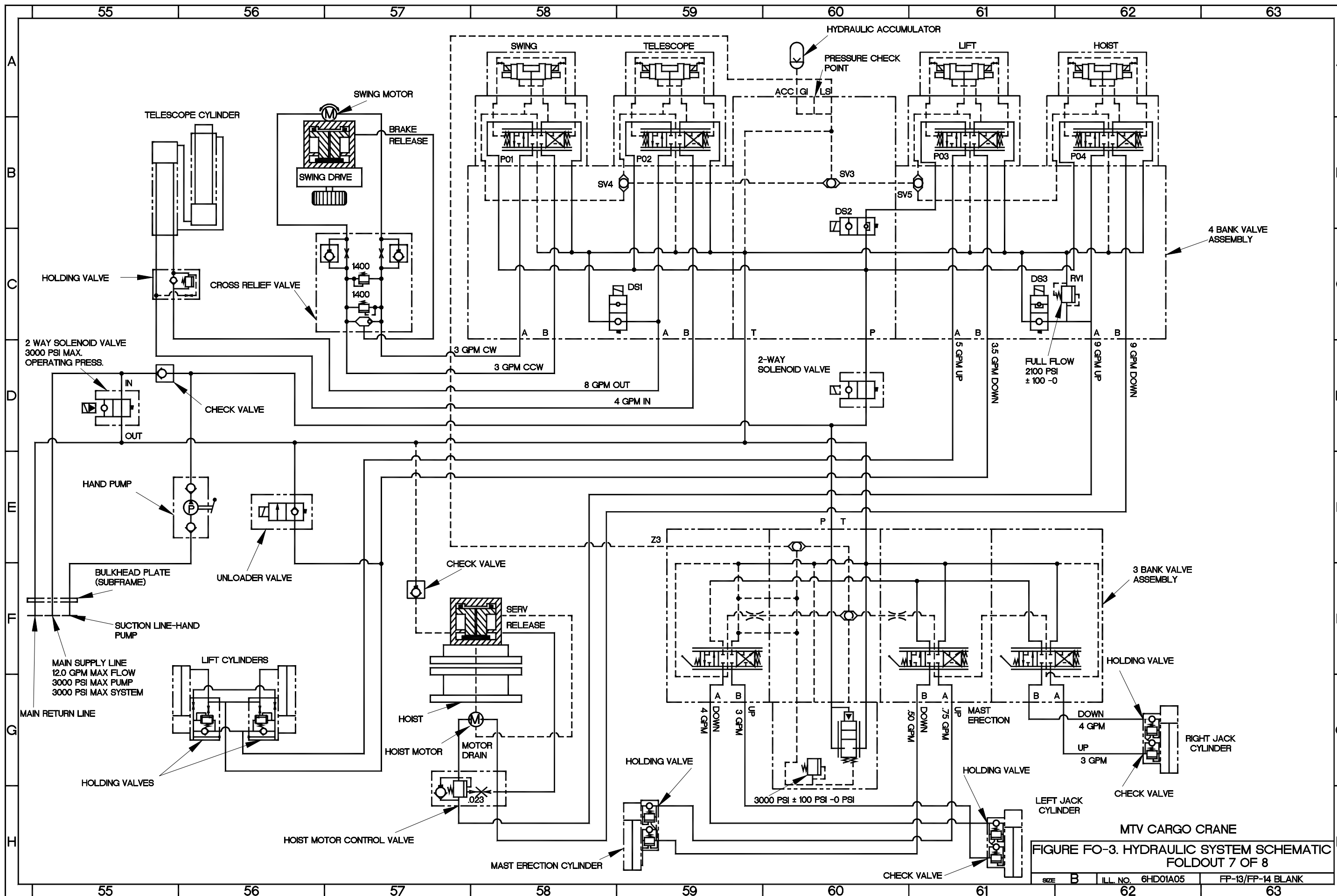

MTV CARGO CRANE
 FIGURE FO-3. HYDRAULIC SYSTEM SCHEMATIC
 FOLDOUT 7 OF 8
 SIZE B ILL. NO. 6HD01A05 FP-13/FP-14 BLANK

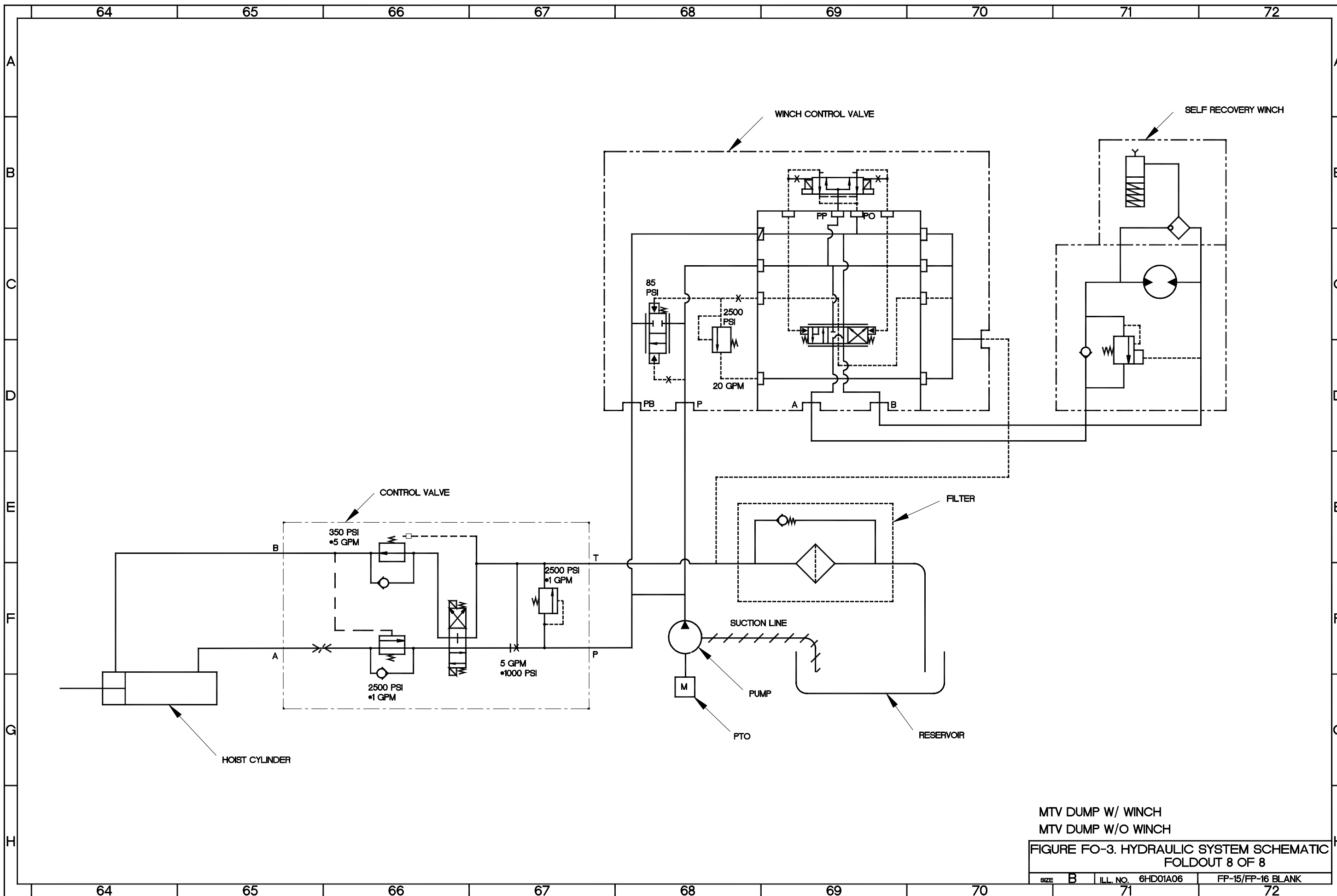

MTV DUMP W/ WINCH
 MTV DUMP W/O WINCH
 FIGURE FO-3. HYDRAULIC SYSTEM SCHEMATIC
 FOLDOUT 8 OF 8

SIZE	B	ILL. NO.	6HD01A06	FP-15/FP-16 BLANK
			71	72

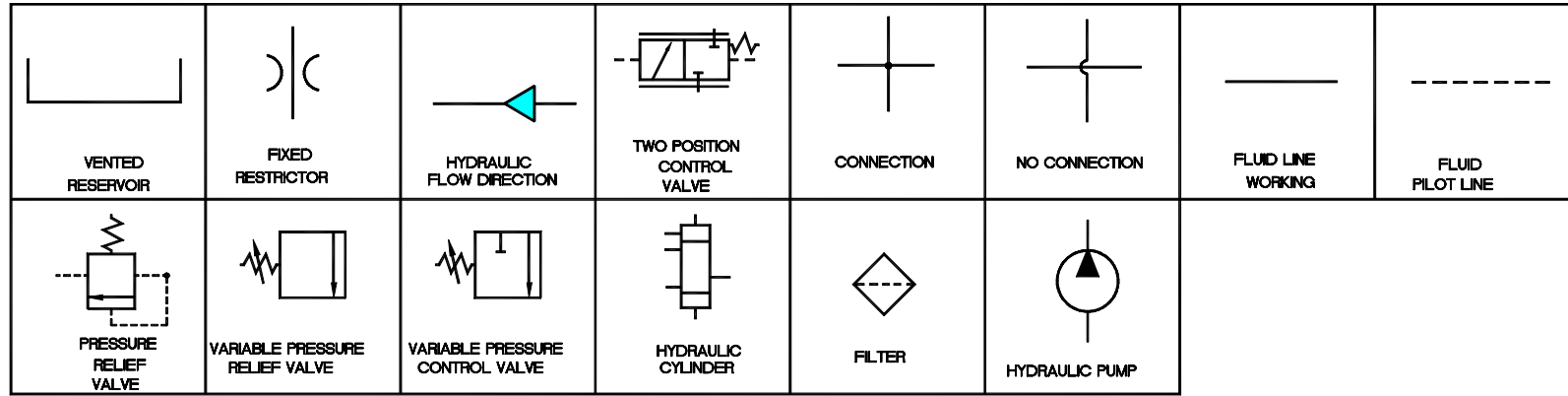
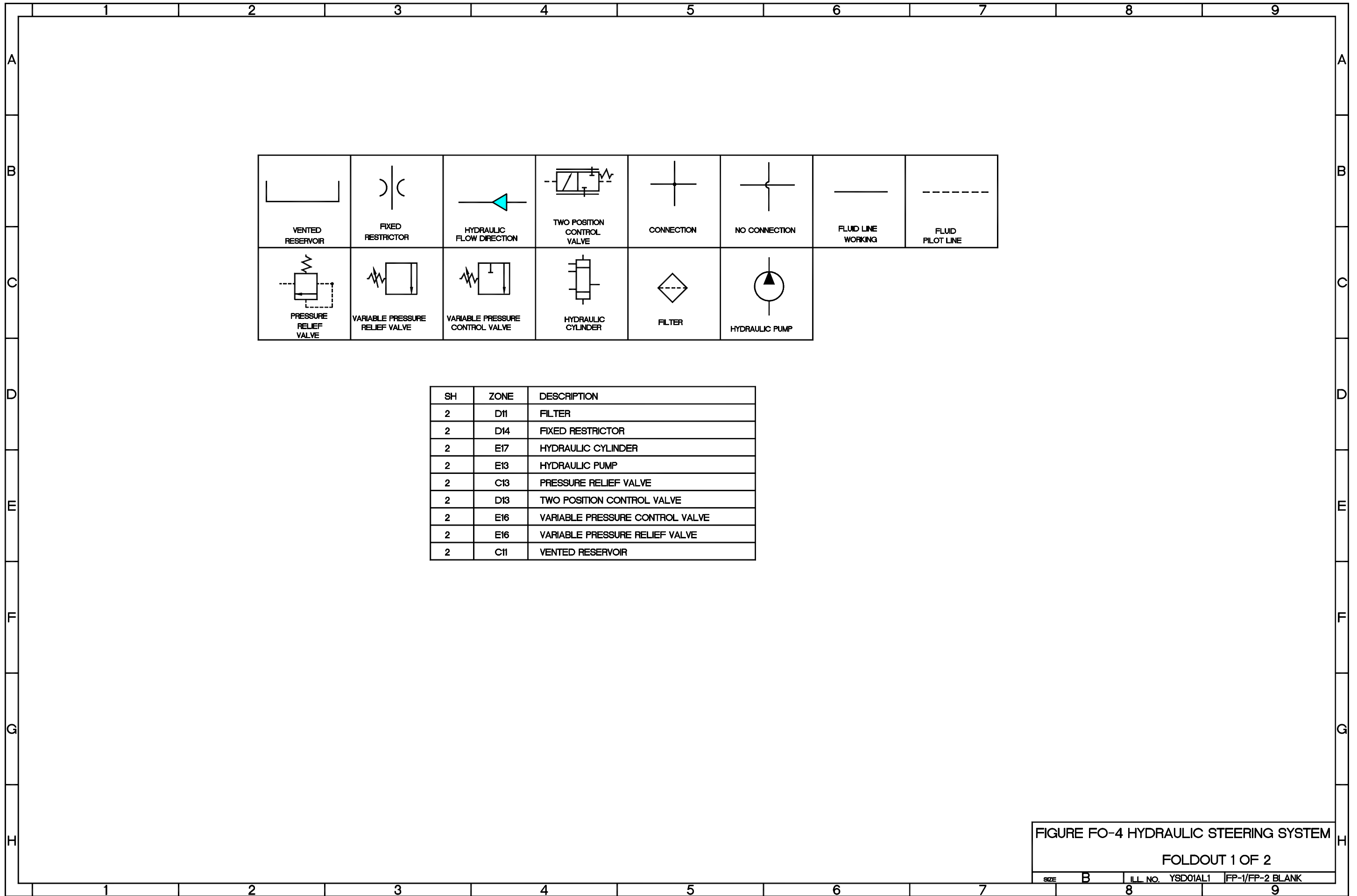

SH	ZONE	DESCRIPTION
2	D11	FILTER
2	D14	FIXED RESTRICTOR
2	E17	HYDRAULIC CYLINDER
2	E13	HYDRAULIC PUMP
2	C13	PRESSURE RELIEF VALVE
2	D13	TWO POSITION CONTROL VALVE
2	E16	VARIABLE PRESSURE CONTROL VALVE
2	E16	VARIABLE PRESSURE RELIEF VALVE
2	C11	VENTED RESERVOIR

FIGURE FO-4 HYDRAULIC STEERING SYSTEM
 FOLDOUT 1 OF 2
 SIZE B ILL. NO. YSD01AL1 FP-1/FP-2 BLANK

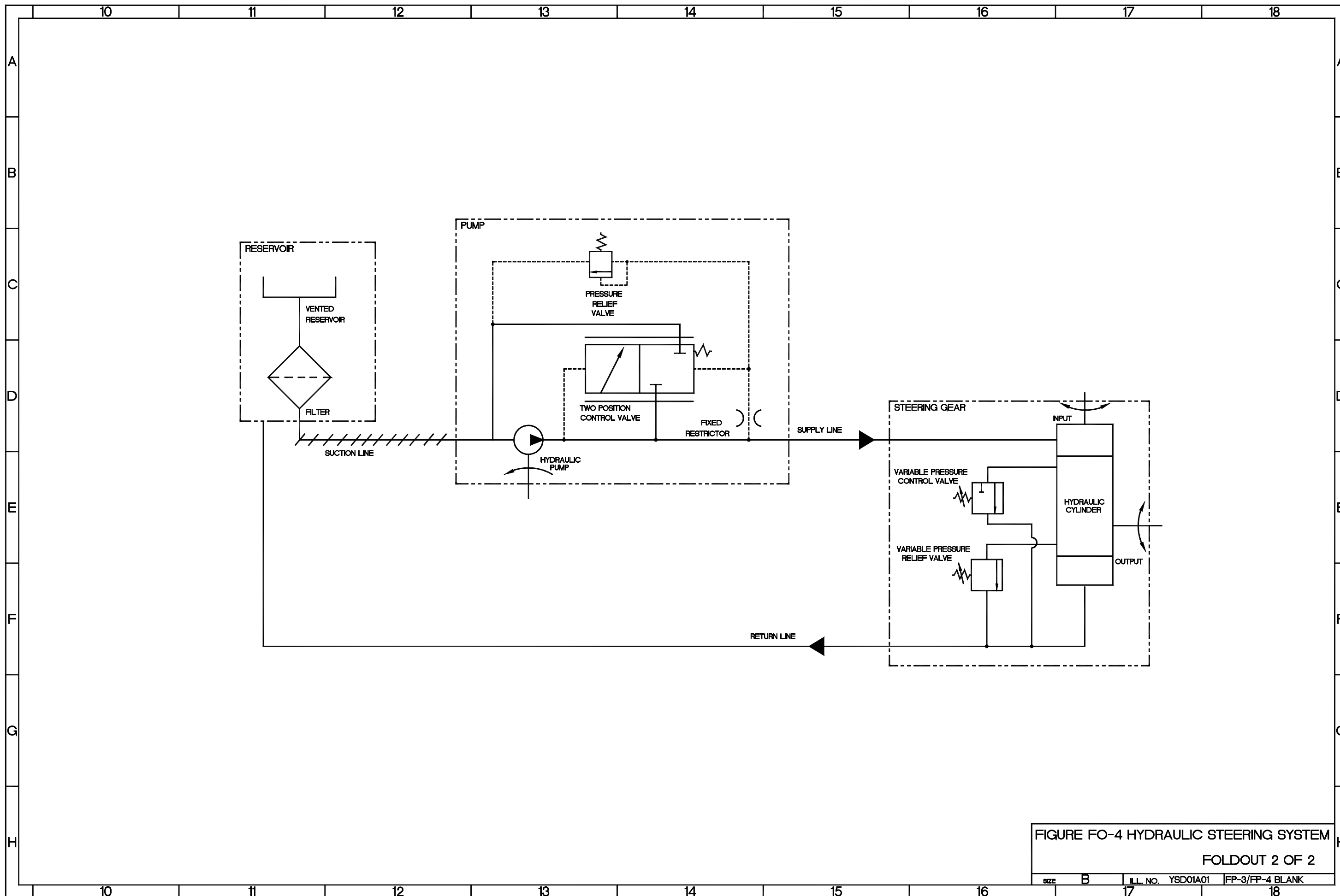

FIGURE FO-4 HYDRAULIC STEERING SYSTEM
 FOLDOUT 2 OF 2
 SIZE B ILL. NO. YSD01A01 FP-3/FP-4 BLANK

	1	2	3	4	5	6	7	8	9
A									
B									
C									
D									
E									
F									
G									
H									







							
VENTED RESERVOIR	ABOVE FLUID LEVEL RESERVOIR	HYDRAULIC FLOW DIRECTION	PNEUMATIC FLOW DIRECTION	CONNECTION	NO CONNECTION	FLUID LINE WORKING	FLUID PILOT LINE
							
FIXED RESTRICTOR	CHECK VALVE	VARIABLE CONTROL CHECK VALVE	CHECK PILOT	PRESSURE RELIEF VALVE	FILTER	HAND PUMP	DETENT
							
TWO POSITION CAB SUSPENSION VALVE	MUFFLER	HYDRAULIC CYLINDER	CAB AIR SUSPENSION W/DAMPER	REAR CAB LATCH	TWO POSITION AIR PUMP VALVE	PRESSURE INTENSIFIER	HEIGHT CONTROL VALVE
							
TWO POSITION CAB TILT VALVE	TWO POSITION SUSPENSION VALVE	TWO POSITION SPARE TIRE VALVE	THREE POSITION SELECTION VALVE				

FIGURE F0-5 AIR TRANSPORTABILITY HYDRAULIC/PNEUMATIC SYSTEM SCHEMATIC
 FOLDOUT 1 OF 3
 SIZE B ILL. NO. YADO1A11 FP-1/FP-2 BLANK

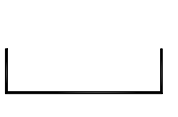
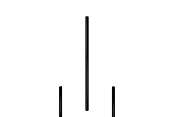
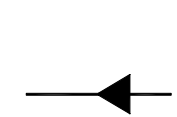
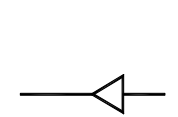
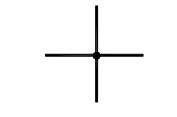
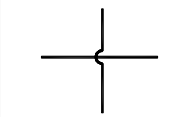
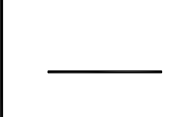
	10	11	12	13	14	15	16	17	18																																																																																																																																														
A	<table border="1"> <thead> <tr> <th>SH</th> <th>ZONE</th> <th>DESCRIPTION</th> </tr> </thead> <tbody> <tr><td>3</td><td>A25</td><td>CAB AIR SUSPENSION W/DAMPER</td></tr> <tr><td>3</td><td>F21</td><td>CHECK PILOT</td></tr> <tr><td>3</td><td>A22</td><td>CHECK VALVE</td></tr> <tr><td>3</td><td>A23</td><td>CHECK VALVE</td></tr> <tr><td>3</td><td>B22</td><td>CHECK VALVE</td></tr> <tr><td>3</td><td>B23</td><td>CHECK VALVE</td></tr> <tr><td>3</td><td>B25</td><td>CHECK VALVE</td></tr> <tr><td>3</td><td>C20</td><td>CHECK VALVE</td></tr> <tr><td>3</td><td>C21</td><td>CHECK VALVE</td></tr> <tr><td>3</td><td>E19</td><td>CHECK VALVE</td></tr> <tr><td>3</td><td>E24</td><td>CHECK VALVE</td></tr> <tr><td>3</td><td>E25</td><td>CHECK VALVE</td></tr> <tr><td>3</td><td>F19</td><td>CHECK VALVE</td></tr> <tr><td>3</td><td>F21</td><td>CHECK VALVE</td></tr> <tr><td>3</td><td>G21</td><td>CHECK VALVE</td></tr> <tr><td>3</td><td>A22</td><td>FILTER</td></tr> <tr><td>3</td><td>B22</td><td>FILTER</td></tr> <tr><td>3</td><td>A24</td><td>FILTER</td></tr> <tr><td>3</td><td>B24</td><td>FILTER</td></tr> <tr><td>3</td><td>D19</td><td>FILTER</td></tr> <tr><td>3</td><td>D20</td><td>FILTER</td></tr> <tr><td>3</td><td>D21</td><td>FILTER</td></tr> <tr><td>3</td><td>E19</td><td>FILTER</td></tr> <tr><td>3</td><td>G19</td><td>FILTER</td></tr> <tr><td>3</td><td>G21</td><td>FILTER</td></tr> <tr><td>3</td><td>A22</td><td>FIXED RESTRICTOR</td></tr> <tr><td>3</td><td>B22</td><td>FIXED RESTRICTOR</td></tr> <tr><td>3</td><td>A23</td><td>FIXED RESTRICTOR</td></tr> <tr><td>3</td><td>B23</td><td>FIXED RESTRICTOR</td></tr> <tr><td>3</td><td>F19</td><td>HAND PUMP</td></tr> <tr><td>3</td><td>B25</td><td>HEIGHT CONTROL VALVE</td></tr> <tr><td>3</td><td>B22</td><td>HYDRAULIC CYLINDER</td></tr> <tr><td>3</td><td>B23</td><td>HYDRAULIC CYLINDER</td></tr> <tr><td>3</td><td>C21</td><td>HYDRAULIC CYLINDER</td></tr> <tr><td>3</td><td>F20</td><td>MUFFLER</td></tr> <tr><td>3</td><td>F21</td><td>PRESSURE INTENSIFIER</td></tr> <tr><td>3</td><td>F19</td><td>PRESSURE RELIEF VALVE</td></tr> <tr><td>3</td><td>A24</td><td>REAR CAB LATCH</td></tr> <tr><td>3</td><td>E21</td><td>THREE POSITION SELECTION VALVE</td></tr> <tr><td>3</td><td>D26</td><td>TWO POSITION AIR PUMP VALVE</td></tr> <tr><td>3</td><td>D25</td><td>TWO POSITION CAB SUSPENSION VALVE</td></tr> <tr><td>3</td><td>C24</td><td>TWO POSITION CAB TILT VALVE</td></tr> <tr><td>3</td><td>C23</td><td>TWO POSITION SPARE TIRE VALVE</td></tr> <tr><td>3</td><td>D21</td><td>TWO POSITION SUSPENSION VALVE</td></tr> <tr><td>3</td><td>G22</td><td>VARIABLE CONTROL CHECK VALVE</td></tr> <tr><td>3</td><td>G22</td><td>VENTED RESERVOIR</td></tr> </tbody> </table>									SH	ZONE	DESCRIPTION	3	A25	CAB AIR SUSPENSION W/DAMPER	3	F21	CHECK PILOT	3	A22	CHECK VALVE	3	A23	CHECK VALVE	3	B22	CHECK VALVE	3	B23	CHECK VALVE	3	B25	CHECK VALVE	3	C20	CHECK VALVE	3	C21	CHECK VALVE	3	E19	CHECK VALVE	3	E24	CHECK VALVE	3	E25	CHECK VALVE	3	F19	CHECK VALVE	3	F21	CHECK VALVE	3	G21	CHECK VALVE	3	A22	FILTER	3	B22	FILTER	3	A24	FILTER	3	B24	FILTER	3	D19	FILTER	3	D20	FILTER	3	D21	FILTER	3	E19	FILTER	3	G19	FILTER	3	G21	FILTER	3	A22	FIXED RESTRICTOR	3	B22	FIXED RESTRICTOR	3	A23	FIXED RESTRICTOR	3	B23	FIXED RESTRICTOR	3	F19	HAND PUMP	3	B25	HEIGHT CONTROL VALVE	3	B22	HYDRAULIC CYLINDER	3	B23	HYDRAULIC CYLINDER	3	C21	HYDRAULIC CYLINDER	3	F20	MUFFLER	3	F21	PRESSURE INTENSIFIER	3	F19	PRESSURE RELIEF VALVE	3	A24	REAR CAB LATCH	3	E21	THREE POSITION SELECTION VALVE	3	D26	TWO POSITION AIR PUMP VALVE	3	D25	TWO POSITION CAB SUSPENSION VALVE	3	C24	TWO POSITION CAB TILT VALVE	3	C23	TWO POSITION SPARE TIRE VALVE	3	D21	TWO POSITION SUSPENSION VALVE	3	G22	VARIABLE CONTROL CHECK VALVE	3	G22	VENTED RESERVOIR	A
SH										ZONE	DESCRIPTION																																																																																																																																												
3										A25	CAB AIR SUSPENSION W/DAMPER																																																																																																																																												
3										F21	CHECK PILOT																																																																																																																																												
3										A22	CHECK VALVE																																																																																																																																												
3										A23	CHECK VALVE																																																																																																																																												
3										B22	CHECK VALVE																																																																																																																																												
3										B23	CHECK VALVE																																																																																																																																												
3										B25	CHECK VALVE																																																																																																																																												
3										C20	CHECK VALVE																																																																																																																																												
3										C21	CHECK VALVE																																																																																																																																												
3										E19	CHECK VALVE																																																																																																																																												
3										E24	CHECK VALVE																																																																																																																																												
3										E25	CHECK VALVE																																																																																																																																												
3										F19	CHECK VALVE																																																																																																																																												
3										F21	CHECK VALVE																																																																																																																																												
3										G21	CHECK VALVE																																																																																																																																												
3										A22	FILTER																																																																																																																																												
3										B22	FILTER																																																																																																																																												
3										A24	FILTER																																																																																																																																												
3										B24	FILTER																																																																																																																																												
3										D19	FILTER																																																																																																																																												
3										D20	FILTER																																																																																																																																												
3										D21	FILTER																																																																																																																																												
3										E19	FILTER																																																																																																																																												
3										G19	FILTER																																																																																																																																												
3										G21	FILTER																																																																																																																																												
3										A22	FIXED RESTRICTOR																																																																																																																																												
3										B22	FIXED RESTRICTOR																																																																																																																																												
3										A23	FIXED RESTRICTOR																																																																																																																																												
3										B23	FIXED RESTRICTOR																																																																																																																																												
3										F19	HAND PUMP																																																																																																																																												
3										B25	HEIGHT CONTROL VALVE																																																																																																																																												
3										B22	HYDRAULIC CYLINDER																																																																																																																																												
3										B23	HYDRAULIC CYLINDER																																																																																																																																												
3										C21	HYDRAULIC CYLINDER																																																																																																																																												
3										F20	MUFFLER																																																																																																																																												
3										F21	PRESSURE INTENSIFIER																																																																																																																																												
3										F19	PRESSURE RELIEF VALVE																																																																																																																																												
3										A24	REAR CAB LATCH																																																																																																																																												
3	E21	THREE POSITION SELECTION VALVE																																																																																																																																																					
3	D26	TWO POSITION AIR PUMP VALVE																																																																																																																																																					
3	D25	TWO POSITION CAB SUSPENSION VALVE																																																																																																																																																					
3	C24	TWO POSITION CAB TILT VALVE																																																																																																																																																					
3	C23	TWO POSITION SPARE TIRE VALVE																																																																																																																																																					
3	D21	TWO POSITION SUSPENSION VALVE																																																																																																																																																					
3	G22	VARIABLE CONTROL CHECK VALVE																																																																																																																																																					
3	G22	VENTED RESERVOIR																																																																																																																																																					
B	B																																																																																																																																																						
C	C																																																																																																																																																						
D	D																																																																																																																																																						
E	E																																																																																																																																																						
F	F																																																																																																																																																						
G	G																																																																																																																																																						
H	H																																																																																																																																																						
	10	11	12	13	14	15	16	17	18																																																																																																																																														

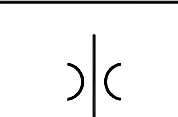
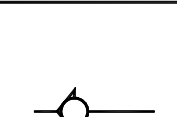
FIGURE FO-5 AIR TRANSPORTABILITY
HYDRAULIC/PNEUMATIC SYSTEM SCHEMATIC
FOLDOUT 2 OF 3

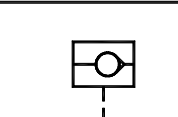
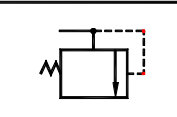
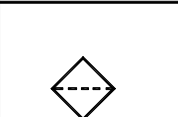
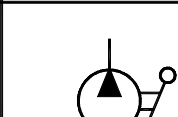
SIZE B ILL. NO. YAD01AL2 FP-3/FP-4 BLANK

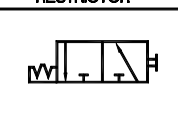
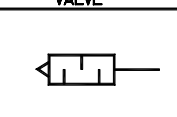
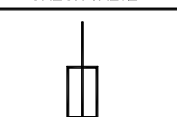
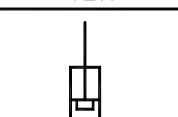
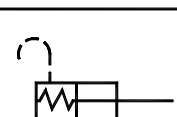
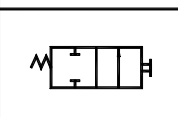
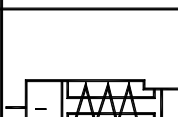
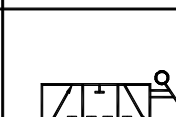
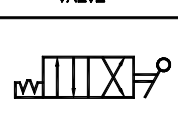
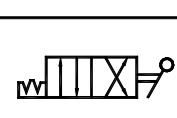
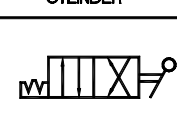
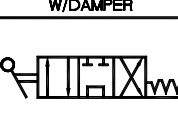
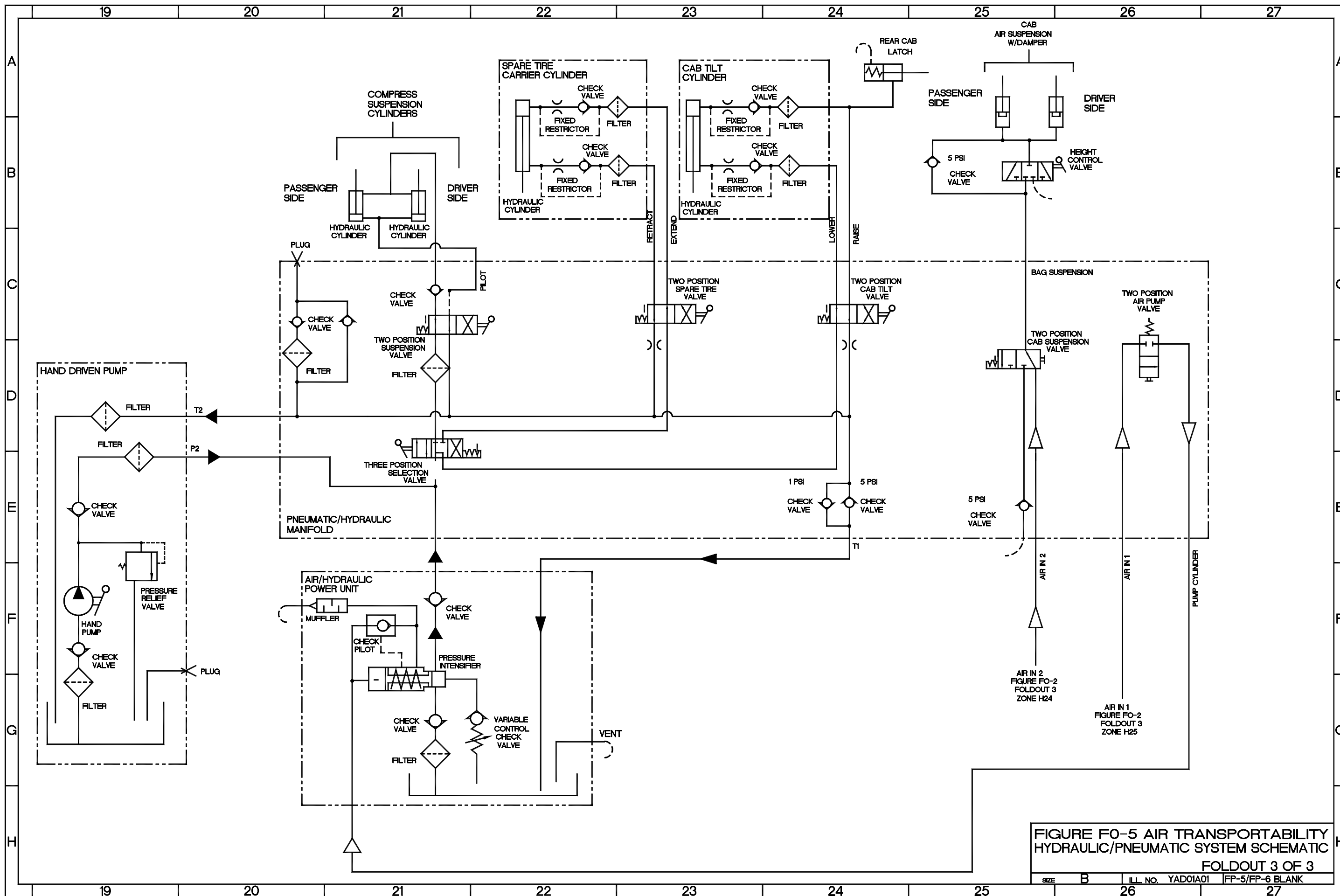

FIGURE FO-5 AIR TRANSPORTABILITY
HYDRAULIC/PNEUMATIC SYSTEM SCHEMATIC
FOLDOUT 3 OF 3

RECOMMENDED CHANGES TO PUBLICATIONS AND BLANK FORMS For use of this form, see AR 25-30; the proponent agency is OAASA	Use Part II (reverse) for Repair Parts and Special Tool Lists (RPSTL) and Supply Catalogs/Supply Manuals (SC/SM).	DATE Date you filled out this form
---	---	--

TO: (Forward to proponent of publication or form) (Include ZIP Code)	FROM: (Activity and location) (Include ZIP Code) Enter your mailing address
---	--

PART I - ALL PUBLICATIONS (EXCEPT RPSTL AND SC/SM) AND BLANK FORMS

PUBLICATION/FORM NUMBER	DATE Publication Date	TITLE Publication Title
-------------------------	--------------------------	----------------------------

ITEM	PAGE	PARA-GRAPH	LINE	FIGURE NO.	TABLE	RECOMMENDED CHANGES AND REASON
10	15-33	15-7		4		<p>Item 10. Change Illustration. Reason: Text calls out 90-degree fitting. Art shows straight fitting. Text is correct.</p> <p>Step (4) of removal says to disconnect four hydraulic hoses from manifold. The correct number of hydraulic hoses is five. correct the text to reflect the actual quantity of hydraulic hoses. The supporting illustration is correct.</p>
	19-6	19-2				

** Reference to line numbers within the paragraph or subparagraph.*

TYPED NAME, GRADE OR TITLE Your title	TELEPHONE EXCHANGE/AUTOVON, PLUS EXTENSION Your telephone number	SIGNATURE Your signature
---	--	--

TO: <i>(Forward direct to addressee listed in publication)</i>	FROM: <i>(Activity and location) (Include ZIP Code)</i>	DATE
	Enter your mailing address	Date you filled out this form.

PART II - REPAIR PARTS AND SPECIAL TOOL LISTS AND SUPPLY CATALOGS/SUPPLY MANUALS

PUBLICATION NUMBER			DATE				TITLE	
			Publication Date				Your Title	
PAGE NO.	COLM NO.	LINE NO.	NATIONAL STOCK NUMBER	REFERENCE NO.	FIGURE NO.	ITEM NO.	TOTAL NO. OF MAJOR ITEMS SUPPORTED	RECOMMENDED ACTION

PART III - REMARKS *(Any general remarks or recommendations, or suggestions for improvement of publications and blank forms. Additional blank sheets may be used if more space is needed.)*

TYPED NAME, GRADE OR TITLE	TELEPHONE EXCHANGE/AUTOVON, PLUS EXTENSION	SIGNATURE
Your title	Your telephone number	Your signature

RECOMMENDED CHANGES TO PUBLICATIONS AND BLANK FORMS						Use Part II (<i>reverse</i>) for Repair Parts and Special Tool Lists (RPSTL) and Supply Catalogs/Supply Manuals (SC/SM).	DATE
For use of this form, see AR 25-30; the proponent agency is OAASA							
TO: (<i>Forward to proponent of publication or form</i>) (<i>Include ZIP Code</i>)				FROM: (<i>Activity and location</i>) (<i>Include ZIP Code</i>)			
PART I - ALL PUBLICATIONS (EXCEPT RPSTL AND SC/SM) AND BLANK FORMS							
PUBLICATION/FORM NUMBER					DATE	TITLE	
ITEM	PAGE	PARA- GRAPH	LINE	FIGURE NO.	TABLE	RECOMMENDED CHANGES AND REASON	
<i>* Reference to line numbers within the paragraph or subparagraph.</i>							
TYPED NAME, GRADE OR TITLE					TELEPHONE EXCHANGE/AUTOVON, PLUS EXTENSION	SIGNATURE	

TO: <i>(Forward direct to addressee listed in publication)</i>	FROM: <i>(Activity and location) (Include ZIP Code)</i>	DATE
---	--	-------------

PART II - REPAIR PARTS AND SPECIAL TOOL LISTS AND SUPPLY CATALOGS/SUPPLY MANUALS

PUBLICATION NUMBER			DATE		TITLE			
PAGE NO.	COLM NO.	LINE NO.	NATIONAL STOCK NUMBER	REFERENCE NO.	FIGURE NO.	ITEM NO.	TOTAL NO. OF MAJOR ITEMS SUPPORTED	RECOMMENDED ACTION

PART III - REMARKS *(Any general remarks or recommendations, or suggestions for improvement of publications and blank forms. Additional blank sheets may be used if more space is needed.)*

TYPED NAME, GRADE OR TITLE	TELEPHONE EXCHANGE/AUTOVON, PLUS EXTENSION	SIGNATURE
----------------------------	--	-----------

RECOMMENDED CHANGES TO PUBLICATIONS AND BLANK FORMS						Use Part II (<i>reverse</i>) for Repair Parts and Special Tool Lists (RPSTL) and Supply Catalogs/Supply Manuals (SC/SM).	DATE
For use of this form, see AR 25-30; the proponent agency is OAASA							
TO: (<i>Forward to proponent of publication or form</i>) (<i>Include ZIP Code</i>)				FROM: (<i>Activity and location</i>) (<i>Include ZIP Code</i>)			
PART I - ALL PUBLICATIONS (EXCEPT RPSTL AND SC/SM) AND BLANK FORMS							
PUBLICATION/FORM NUMBER						DATE	TITLE
ITEM	PAGE	PARA-GRAPH	LINE	FIGURE NO.	TABLE	RECOMMENDED CHANGES AND REASON	
<i>* Reference to line numbers within the paragraph or subparagraph.</i>							
TYPED NAME, GRADE OR TITLE					TELEPHONE EXCHANGE/AUTOVON, PLUS EXTENSION		SIGNATURE

TO: <i>(Forward direct to addressee listed in publication)</i>	FROM: <i>(Activity and location) (Include ZIP Code)</i>	DATE
---	--	-------------

PART II - REPAIR PARTS AND SPECIAL TOOL LISTS AND SUPPLY CATALOGS/SUPPLY MANUALS

PUBLICATION NUMBER			DATE		TITLE			
PAGE NO.	COLM NO.	LINE NO.	NATIONAL STOCK NUMBER	REFERENCE NO.	FIGURE NO.	ITEM NO.	TOTAL NO. OF MAJOR ITEMS SUPPORTED	RECOMMENDED ACTION

PART III - REMARKS *(Any general remarks or recommendations, or suggestions for improvement of publications and blank forms. Additional blank sheets may be used if more space is needed.)*

TYPED NAME, GRADE OR TITLE	TELEPHONE EXCHANGE/AUTOVON, PLUS EXTENSION	SIGNATURE
----------------------------	--	-----------

RECOMMENDED CHANGES TO PUBLICATIONS AND BLANK FORMS						Use Part II (<i>reverse</i>) for Repair Parts and Special Tool Lists (RPSTL) and Supply Catalogs/Supply Manuals (SC/SM).	DATE
For use of this form, see AR 25-30; the proponent agency is OAASA							
TO: (<i>Forward to proponent of publication or form</i>) (<i>Include ZIP Code</i>)				FROM: (<i>Activity and location</i>) (<i>Include ZIP Code</i>)			
PART I - ALL PUBLICATIONS (EXCEPT RPSTL AND SC/SM) AND BLANK FORMS							
PUBLICATION/FORM NUMBER						DATE	TITLE
ITEM	PAGE	PARA- GRAPH	LINE	FIGURE NO.	TABLE	RECOMMENDED CHANGES AND REASON	
<i>* Reference to line numbers within the paragraph or subparagraph.</i>							
TYPED NAME, GRADE OR TITLE				TELEPHONE EXCHANGE/AUTOVON, PLUS EXTENSION		SIGNATURE	

TO: <i>(Forward direct to addressee listed in publication)</i>	FROM: <i>(Activity and location) (Include ZIP Code)</i>	DATE
---	--	-------------

PART II - REPAIR PARTS AND SPECIAL TOOL LISTS AND SUPPLY CATALOGS/SUPPLY MANUALS

PUBLICATION NUMBER			DATE		TITLE			
PAGE NO.	COLM NO.	LINE NO.	NATIONAL STOCK NUMBER	REFERENCE NO.	FIGURE NO.	ITEM NO.	TOTAL NO. OF MAJOR ITEMS SUPPORTED	RECOMMENDED ACTION

PART III - REMARKS *(Any general remarks or recommendations, or suggestions for improvement of publications and blank forms. Additional blank sheets may be used if more space is needed.)*

TYPED NAME, GRADE OR TITLE	TELEPHONE EXCHANGE/AUTOVON, PLUS EXTENSION	SIGNATURE
----------------------------	--	-----------

THE METRIC SYSTEM AND EQUIVALENTS

LINEAR MEASURE

1 Centimeter = 10 Millimeters = 0.01 Meters = 0.3937 Inches
 1 Meter = 100 Centimeters = 1000 Millimeters = 39.37 Inches
 1 Kilometer = 1000 Meters = 0.621 Miles

SQUARE MEASURE

1 Sq Centimeter = 100 Sq Millimeters = 0.155 Sq Inches
 1 Sq Meter = 10,000 Sq Centimeters = 10.76 Sq Feet
 1 Sq Kilometer = 1,000,000 Sq Meters = 0.386 Sq Miles

WEIGHTS

1 Gram = 0.001 Kilograms = 1000 Milligrams = 0.035 Ounces
 1 Kilogram = 1000 Grams = 2.2 Lb
 1 Metric Ton = 1000 Kilograms = 1 Megagram = 1.1 Short Tons

CUBIC MEASURE

1 Cu Centimeter = 1000 Cu Millimeters = 0.06 Cu Inches
 1 Cu Meter = 1,000,000 Cu Centimeters = 35.31 Cu Feet

LIQUID MEASURE

1 Milliliter = 0.001 Liters = 0.0338 Fluid Ounces
 1 Liter = 1000 Milliliters = 33.82 Fluid Ounces

TEMPERATURE

$5/9 (°F - 32) = °C$
 212° Fahrenheit is equivalent to 100° Celsius
 90° Fahrenheit is equivalent to 32.2° Celsius
 32° Fahrenheit is equivalent to 0° Celsius
 $9/5 C° + 32 = F°$

APPROXIMATE CONVERSION FACTORS

<u>TO CHANGE</u>	<u>TO</u>	<u>MULTIPLY BY</u>	<u>TO CHANGE</u>	<u>TO</u>	<u>MULTIPLY BY</u>
Inches	Centimeters	2.540	Centimeters	Inches	0.394
Inches	Millimeters	25.4	Millimeters	Inches	0.0394
Feet	Meters	0.305	Meters	Feet	3.280
Yards	Meters	0.914	Meters	Yards	1.094
Miles	Kilometers	1.609	Kilometers	Miles	0.621
Square Inches	Square Centimeters	6.451	Sq Centimeters	Square Inches	0.155
Square Feet	Square Meters	0.093	Square Meters	Square Feet	10.764
Square Yards	Square Meters	0.836	Square Meters	Square Yards	1.196
Square Miles	Square Kilometers	2.590	Square Kilometers	Square Miles	0.386
Acres	Square Hectometers	0.405	Sq Hectometers	Acres	2.471
Cubic Feet	Cubic Meters	0.028	Cubic Meters	Cubic Feet	35.315
Cubic Yards	Cubic Meters	0.765	Cubic Meters	Cubic Yards	1.308
Fluid Ounces	Milliliters	29.57	Milliliters	Fluid Ounces	0.034
Pints	Liters	0.473	Liters	Pints	2.113
Quarts	Liters	0.946	Liters	Quarts	1.057
Gallons	Liters	3.785	Liters	Gallons	0.264
Ounces	Grams	28.35	Grams	Ounces	0.035
Pounds	Kilograms	0.454	Kilograms	Pounds	2.205
Pounds (force)	Newtons	4.448	Newtons	Pounds (force)	0.2248
Short Tons	Metric Tons	0.907	Metric Tons	Short Tons	1.102
Pound-Feet	Newton-Meters	1.356	Newton-Meters	Pound-Feet	0.738
Pounds/Sq Inch	Kilopascals	6.895	Kilopascals	Pounds per Sq Inch	0.145
Miles per Gallon	Kilometers per Liter	0.425	Km per Liter	Miles per Gallon	2.354
Miles per Hour	Kilometers per Hour	1.609	Km per Hour	Miles per Hour	0.621

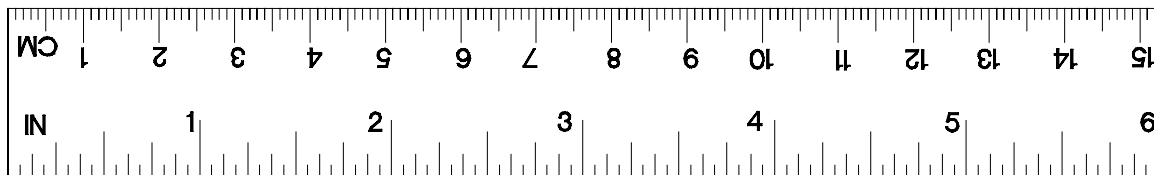

YMET001A

